



From "The Civilization of Babylonia and Assyria," J. B. Lippincott Co.
FIG. 1.—Statue of Lugal-daudu, King of Adab (3000 B.C.) Showing Eye-Sockets Lined
with Asphalt.

Frontispiece

ASPHALTS AND ALLIED SUBSTANCES

Their Occurrence, Modes of Production,
Uses in the Arts and Methods of Testing

BY

HERBERT ABRAHAM

B.S. of Chemistry, Member A.C.S., S.C.I., A.S.T.M., I.A.T.M.

208 ILLUSTRATIONS

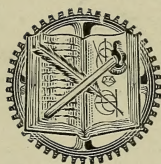

NEW YORK
D. VAN NOSTRAND COMPANY
25 PARK PLACE
1918

TN 853
A35

Copyright, 1918

BY

D. VAN NOSTRAND COMPANY

18-19991

OCT 21 1918

PRESS OF
BRAUNWORTH & CO.
BOOK MANUFACTURERS
BROOKLYN, N. Y.

©CL.A506249

DEDICATED TO

Ralph L. Shainwald

AS A TOKEN OF ESTEEM AND IN
APPRECIATION OF MANY PLEASANT
YEARS OF BUSINESS ASSOCIATION

PREFACE

THIS treatise has been written for those interested in the fabrication, merchandising and application of bituminous products. It embraces: (1) methods serving as a guide for the works chemist engaged in testing and analyzing raw and manufactured products; (2) data for assisting the refinery or factory superintendent in blending and compounding mixtures; (3) information enabling the ambitious salesman to enlarge his knowledge concerning the scope and limitations of the articles he vends; and (4) the principles underlying the practical application of bituminous products for structural purposes, of interest to the engineer, contractor and architect. Subject-matter of sole value to the technical man has been segregated in Part V, "Methods of Testing," excepting the outline of the "Chemistry of Bituminous Substances" appearing in Chapter III. These sections, however, may be passed over by the non-technical man, without interfering materially with the continuity of the work.

In view of the vast amount of ground covered in this volume, and fully realizing the limitations of his proficiency in some of its branches and ramifications, the author has taken it upon himself to draw freely from contemporary text-books and journal articles. In such instances, his endeavor has been to place due credit where it belongs, by referring to the source of such extraneous information. Nevertheless, there has been included a substantial amount of original data accumulated by the author during the past nineteen years, most of which appears in print herein for the first time.

Topics which have been ably presented in other reference books, as for example the technology of pavements, etc., have purposely been subordinated to those concerning which little data has hitherto been available. To the latter belong such subjects as petroleum asphalts; fatty-acid pitches; bituminized roofings, floorings and other fabrics; bituminous paints, cements, varnishes and japans.

Certain branches of the industry have developed along different lines in Europe than has been the case in this country, especially the treat-

ment of peat and lignite (Chapter XV), also pyrobituminous shales (Chapter XVI). In such instances, the methods in vogue abroad before the great war are described with more or less detail. It must be borne in mind in this connection, that the war has materially interfered with the prosecution of these industries abroad, and the data presented should be so construed, even though not specifically stated in the text.

Whereas the greatest pains have been taken to establish the accuracy of every assertion, as well as the authenticity of every alleged fact, the author does not flatter himself that he has escaped the pitfalls which must perforce beset the path of a writer who undertakes to delve into a subject as complicated as the one under consideration, concerning which there are so many divergent views.

Appreciation is expressed for the valuable suggestions and assistance rendered by W. A. Hamor, D. R. Steuart, Prévost Hubbard, S. R. Church, E. B. Cobb, David Wesson, Clifford Richardson, S. C. Ells, and the author's immediate associates.

HERBERT ABRAHAM.

NEW YORK CITY, July 1, 1918.

TABLE OF CONTENTS

PART I.—GENERAL CONSIDERATIONS

CHAPTER I

	PAGE
HISTORICAL REVIEW	1

Origin of the Words "Asphalt" and "Bitumen"—Use of Asphalt by the Sumerians (about 3000 to 2500 B.C.)—Use of Asphalt by the Early Persians (about 2800 to 2500 B.C.)—Use of Asphalt by the Early Egyptians (about 2500 B.C.)—Use of Asphalt in Biblical Times (2500 to 1500 B.C.)—Use of Asphalt by the Babylonians (700 to 500 B.C.)—About 450 B.C., Herodotus of Persia—About 430 B.C., Xenophon of Greece—About 400 B.C., Hippocrates of Greece—About 350 B.C., Aristotle of Greece—About 250 B.C., Hannibal of Carthage—About 80 B.C., Diodorus Siculus of Sicily—About 30 B.C., Strabo of Greece—About 25 B.C., Marcus Vitruvius of Rome—About 60 A.D., Dioscorides of Greece—About 100 A.D., Pliny the Elder of Rome—About 1300 A.D., Marco Polo of Venice—1535, Discovery of Asphalt in Cuba—1595, Discovery of "Pitch Lake" in Trinidad by Sir Walter Raleigh—1601, First Classification of Bituminous Substances—1656, Early Dictionary Definition of "Bitumen"—1661, Commercial Production of Wood Tar—1672, First Accurate Description of Persian Asphalt Deposits—1873, Discovery of Elaterite—1681, Discovery of Coal Tar and Coal-tar Pitch—1691, Discovery of Illuminating Gas from Coal—1694, Discovery of Shale Tar and Shale-tar Pitch—1712-30, Discovery of Val de Travers, Linmer and Seyssel Asphalt Deposits—1746, Invention of the Process of Refining Coal Tar—1777, First Exposition of Modern Theory of the Origin of Asphalt—1788, Discovery of Lignite Tar—1790-1800, Discovery of "Composition" or "Prepared" Roofing—1792-1802, Manufacture of Coal Gas and Coal Tar on a Large Scale—1797-1802, Exploitation of Seyssel Asphalt in France—1815, Commercial Exploitation of Coal-tar Solvents—1822, Discovery of Scheererite and Hatchettite—1830, Discovery of Paraffine Wax—1833, Discovery of Ozokerite—1836, Asphalt First Used in London for Foot Pavements—1837, Publication of First Exhaustive Treatise on the Chemistry of Asphalt—1838, Discovery of Process for Preserving Wood with Coal-tar Creosote—1838, Asphalt First Used in the United States for Foot Pavements—1842, Discovery of Bituminous Matter in the United States—1843, Bituminous Matters Discovered in New York State—1850, Discovery of "Asphaltic Coal" in New Brunswick, Nova Scotia—1854, First Compressed Asphalt Roadway Laid in Paris—1858, First Modern Asphalt Pavement Laid in Paris—1863, Discovery of Grahamite in West Virginia—1869, The First Compressed Asphalt Pavement in London—1870-1876, First Asphalt Roadways in

the United States—1879, First Trinidad Asphalt Pavement Laid in the United States—1881, Use of Chemicals for Oxidizing Coal Tars and Petroleum Asphalts—1885, Discovery of Uintaite (Gilsonite) in Utah—1889, Discovery of Wurtzilite in Utah—1891, Exploitation of the Bermudez Asphalt Deposit, Venezuela—1894, Use of Air for Oxidizing Petroleum Asphalt.

CHAPTER II

TERMINOLOGY AND CLASSIFICATION OF BITUMINOUS SUBSTANCES... 19

Bituminous Substances—Bitumen—Pyrobitumen—Petroleum—Mineral Wax—Asphalt—Asphaltite—Asphaltic Pyrobitumen—Non-asphaltic Pyrobitumen—Tar—Pitch.

CHAPTER III

CHEMISTRY OF BITUMINOUS SUBSTANCES..... 28

Structural Formulas of the Most Important Pure Chemical Substances Present in Bituminous Complexes—*Open Chain Hydrocarbons*— C_nH_{2n+2} Series, Saturated, Single Bonds, "Paraffines"— C_nH_n Series, Unsaturated, One Double Bond, "Olefines"— C_nH_{n-2} Series, Unsaturated, One Triple Bond, "Acetylenes"— C_nH_{2n-2} Series, Unsaturated, Two Double Bonds, "Diolefines"— C_nH_{2n-4} Series, Unsaturated, One Double and One Triple Bond, "Olefinacetylenes"— C_nH_{2n-4} Series, Unsaturated, Three Double Bonds, "Polyolefines"— C_nH_{2n-6} Series, Unsaturated, Two Triple Bonds, "Diacetylenes"—*Cyclic Hydrocarbons*— C_nH_{2n} Series, Saturated, Single Bonds, Monocyclic, "Naphthenes," also called "Cycloparaffines" or "Polymethylenes"— C_nH_{2n-2} Series, Saturated, Single Bonds, Polycyclic, "Polycyclic Polymethylenes"— C_nH_{2n-2} Series, Unsaturated, One Double Bond, Monocyclic, "Cyclo-Olefines"— C_nH_{2n-4} Series, Unsaturated, Two Double Bonds, Monocyclic, "Terpenes"— C_nH_{2n-4} Series, Saturated, Single Bonds, "Polycyclic Polynaphthenes"— C_nH_{2n-6} Series, Unsaturated, Three Double Bonds, Monocyclic, "Benzenes"— C_nH_{2n-8} to C_nH_{2n-30} Series, Unsaturated, Monocyclic and Polycyclic—*Oxygenated Bodies*—*Nitrogenous Bodies*—*Sulphurated Bodies*—**Percentages of the Elements Present in Bituminous Substances.**

CHAPTER IV

GEOLOGY AND ORIGIN OF BITUMENS AND PYROBITUMENS..... 46

Geology—*Age of the Geological Formations*—*Character of the Associated Minerals*—*Modes of Occurrence*—Springs—Lakes—Seepages—Subterranean Pools or Reservoirs—Impregnated Rock in Strata—Filling Veins—*Movement of Bitumens in the Earth's Strata*—Hydrostatic Pressure—Gas Pressure—Capillarity—Gravitation—Effect of Heat—**Origin and Metamorphosis of Bitumens and Asphaltic**

PAGE

Pyrobitumens—Probable Origin of Bitumens and Asphaltic Pyrobitumens—
Inorganic Theories—Vegetable Theories—Animal Theories—Metamorphosis of
Mineral Waxes, Asphalts, Asphaltites and Asphaltic Pyrobitumens from Petroleum
—Origin and Metamorphosis of Non-Asphaltic Pyrobitumens.

CHAPTER V

ANNUAL PRODUCTION OF ASPHALTS, ASPHALTITES AND ASPHALTIC
PYROBITUMENS 62

World Production—Production in United States—Production by States—
Imports—Exports—Consumption of Asphalt in the United States.

*PART II.—SEMI-SOLID AND SOLID NATIVE BITUMINOUS
SUBSTANCES*

CHAPTER VI

METHODS OF REFINING 68

Dehydration—Sedimentation—Extraction by Means of Water—Extraction
with Solvents.

CHAPTER VII

MINERAL WAXES 74

Ozokerite—Galicia—Rumania—Russia—United States—*Hatchettite* or
Hatchettine—*Scheererite*—*Kabaite*—*Montan Wax*.

CHAPTER VIII

NATIVE ASPHALTS OCCURRING IN A FAIRLY PURE STATE 82

North America—*United States*—Kentucky—Oklahoma—Utah—California—
Oregon—*Mexico*—State of Tamaulipas—State of Vera Cruz—*Cuba*—Province of
Matanzas—**South America**—*Venezuela*—State of Bermudez—State of Zulia
—**Europe**—*France*—Department of Puy-de-Dôme—*Albania*—Selenitza—*Greece*—
Zante—**Asia**—*Syria*—*Eastern Siberia*—Sakhalin—**Philippine Islands**—Island of
Leyte.

CHAPTER IX

	PAGE
NATIVE ASPHALTS ASSOCIATED WITH MINERAL MATTER	92

North America—*United States*—Kentucky—Missouri—Indiana—Oklahoma—Louisiana—Texas—Utah—California—*Canada*—Alberta—*Mexico*—*Cuba*—Province of Matanzas—Province of Pinar del Rio—Province of Havana—Province of Camaguey—**South America**—*Trinidad*—*Argentine*—Province of Jujuy—Province of Chubut—**Europe**—*France*—Department of Landes—Department of Gard—Department of Haute-Savoie—Department of Ain—*Switzerland*—*Alsace-Lorraine*—*Germany*—Province of Hanover—Province of Westphalia—Province of Hessen—*Austria*—Province of Dalmatia—Province of Tyrol—Province of Bihar—Province of Herzegovina—*Italy*—Compartment of Marches—Compartment of Abruzzi ed Molise—Compartment of Calabria—Compartment of Campania—Compartment of Sicily—*Greece*—District of Triphily—*Portugal*—Province of Estremadura—*Spain*—Province of Santander—Province of Alava—Province of Navarre—Province of Tarragona—Province of Soria—*Russia*—Province of Terek—Province of Simbirsk—**Asia**—*Japan*—Ugo Province—*Asiatic Russia*—Province of Uralsk—*Syria*—*Mesopotamia*—*Arabia*—**Africa**—*Algeria*—Province of Oran—*Nigeria*—*Rhodesia*.

CHAPTER X

ASPHALTITES	127
-----------------------	-----

Gilsonite or **Uintaite**—*United States*—Utah—**Glance Pitch**—*Mexico*—Chapapote—*West Indies*—Barbados—Santo Domingo (Hayti)—*Colombia*—(South America)—*Syria*—Hasbaya—Dead Sea—*Egypt*—**Grahamite**—*United States*—West Virginia—Texas—Oklahoma—Colorado—*Mexico*—Province of Vera Cruz—Province of Tamaulipas—*Cuba*—Province Pinar del Rio—Province of Havana—Province of Santa Clara—*Trinidad*.

CHAPTER XI

ASPHALTIC PYROBITUMENS	149
----------------------------------	-----

Elaterite—*England*—Derbyshire County—*Australia*—State of South Australia—*Asiatic Russia*—Province of Semiryechensk—**Wurtzilite**—*United States*—Utah—**Albertite**—*Canada*—Province of New Brunswick—Province of Nova Scotia—*United States*—Utah—*Australia*—Tasmania—*West Africa*—Libollo—**Imponite**—*United States*—Oklahoma—Arkansas—Nevada.

CHAPTER XII

PYROBITUMINOUS SHALES	158
---------------------------------	-----

Torbanite—Pyropissite—*United States*—*Canada*—Province of New Brunswick—Province of Nova Scotia—Province of Newfoundland—Province of Quebec—

Brazil—Province of Bahia—*England*—*Scotland*—*Germany*—*Spain*—*Austria*—*Australia*—New South Wales—New Zealand—Tasmania—Queensland—Victoria.

PART III.—TARS AND PITCHES

CHAPTER XIII

GENERAL METHODS OF PRODUCING TARS 165

Destructive Distillation—Composition of the Substance—The Temperature—The Time of Heating—The Pressure—Upon the Efficiency of the Condensing System—**Partial Combustion with Air and Steam**—**Partial Combustion with a Limited Access of Air**—**Cracking of Oil Vapors**—**Methods of Separating Tars**—*Condensers*—Hydraulic Main—Air-condensers—Water-condensers—*Static Scrubbers*—Rain Scrubbers—Hurdle Scrubbers—Baffle Scrubbers—*Mechanical Scrubbers*—Feld Centrifugal Scrubber—Reading Centrifugal Scrubber—Thiesen Centrifugal Scrubber—Schwarz-Bayer Disintegrator—*Deflectors*—P. & A. Tar Extractor—Centrifugal Deflector—*Filters*—Smith Tar Extractor—*Electrical Precipitators*—Cottrell System—**Methods of Dehydrating Tars**—Settling Tanks—Baffle-plate Separator—Heating Quietly under Pressure—Wilton Process—Heating a Thin Stream under Vacuum—Centrifugal Method—Electrical Method—Feld System of Fractional Cooling.

CHAPTER XIV

WOOD TAR, WOOD-TAR PITCH AND ROSIN PITCH 184

Wood Tar and Wood-Tar Pitch—Varieties of Wood Used—Yields of Distillation—*Hardwood Distillation*—Retorts—Method of Distilling—Refining Processes—*Soft (Resinous) Wood Distillation*—Retorts—Method of Distillation—Refining Processes—“Stockholm Tar”—Physical and Chemical Characteristics of Hardwood Tar and Pine Tar—Physical and Chemical Characteristics of Hardwood-Tar Pitch and Pine-Tar Pitch—**Rosin Pitch**—Raw Materials Used—Still Used—Methods of Distillation—Products Obtained—Physical and Chemical Characteristics of Rosin Pitch—“Burgundy Pitch.”

CHAPTER XV

PEAT AND LIGNITE TARS AND PITCHES 197

Peat Tar and Peat-Tar Pitch—Formation of Peat—Varieties of Peat—Characteristics of Peat—Methods of Collecting—Dehydrating Processes—Methods of Distillation—Ziegler Process—Destructive Distillation and Yields—Utilization of Peat for Manufacturing Producer Gas—Properties of Peat Tar—Production of

Peat-Tar Pitch—**Lignite Tar and Lignite-Tar Pitch**—Varieties of Lignite Available—Kinds Suitable for Distillation—Mining Methods—Retorts Used—Products Obtained on Destructive Distillation and Yields—Methods of Treating Impure Lignite—Use of Lignite for Manufacturing Producer Gas—Properties of Lignite Tar—Refining of Lignite Tar—Stills Used—Refined Products Obtained and Their Yields—Methods of Purification—Production of Lignite-Tar Pitch—Properties of Lignite-Tar Pitches.

CHAPTER XVI

SHALE TAR AND SHALE-TAR PITCH..... 216

Shale Mining—Retorts Used for Distillation—Pumpherson Retort—Young & Fyfe Retort—Henderson Retort—Del Monte Retort—Methods of Recovering Shale Tar—Products Obtained and their Yields—Properties of Shale Tar—Refining of Shale Tar—Products Obtained—Methods of Purification.

CHAPTER XVII

COAL TAR AND COAL-TAR PITCH..... 225

Bituminous Coals Used—Chemical Composition of Coals—*Production of Gas-Works Coal Tar*—Retorts Used—Methods of Recovery—Products Obtained and Their Yields—*Production of Coke-Oven Coal Tar*—Annual Production—Semet-Solvay Coke-Oven—Otto-Hoffman Coke-Oven—United-Otto Coke-Oven—Koppers Coke-Oven—*Production of Blast-Furnace Coal Tar*—Methods of Recovery and Yields—*Production of Producer-Gas Coal Tar*—Types of Producers Used—*Properties of Coal Tars*—Properties of Gas-Works Coal Tar, Coke-Oven Coal Tar, Blast-Furnace Coal Tar and Producer-Gas Coal Tar—*Refining of Coal Tar*—Stills Used—Distillation Products and their Yields—Continuous Distillation Processes—Feld Fractional Condensing System—Commercial Varieties of Coal Tar and Coal-Tar Pitch—*Properties of Coal-Tar Pitches*—Properties of Gas-Works Coal-Tar Pitch, Coke-Oven Coal-Tar Pitch, Blast-Furnace Coal-Tar Pitch and Producer-Gas Coal-Tar Pitch.

CHAPTER XVIII

WATER-GAS AND OIL-GAS TARS AND PITCHES..... 256

Water-gas Tar—Method of Production—Yields—Properties of Dehydrated Water-Gas Tar—*Oil-Gas Tars*—Methods of Production—Pintsch Gas—Oil-Water Gas—Blau Gas—Properties of Oil-Gas Tars. *Refining of Water-Gas and Oil-Gas Tars*—*Properties of Water-Gas-Tar Pitch and Oil-Gas-Tar Pitch*.

CHAPTER XIX

	PAGE
PETROLEUM ASPHALTS	265

Varieties of Petroleum—Products Obtained from Petroleum—*Distillates*—Gasoline—Naphtha—Kerosene—Gas or Fuel Oil—Lubricating Oil—Paraffine Wax—Wax Tailings—*Residues*—Residual Oil—Residual Asphalt—Blown Asphalt—Sulphurized Asphalt—Sludge Asphalt—Coke—Petrolatum—**Dehydration of Petroleum**—Settling—Heating under Pressure—Milliff Hot-Air System—Electrical Method—**Methods of Refining Petroleum**—*Intermittent Distillation Processes*—Dry Distillation—Steam Distillation—*Continuous Distillation Processes*—Topping Process—Livingston Process—*Steam Distillation of Asphalt-Bearing Petroleum*—Process Used—Products Obtained and their Yields—*Steam Distillation of Non-Asphaltic and Mixed-Base Petroleums*—Process Used—Products Obtained and Their Yields—*Dry Distillation of Non-Asphaltic and Mixed-Base Petroleums*—Process Used—Products Obtained and Their Yields—**Residual Oils**—Varieties Obtained—Physical and Chemical Characteristics—**Blown Asphalts**—Processes Used—Advantages of “Blowing” Over the Steam-Distillation Process—Physical and Chemical Characteristics—**Sulphurized Asphalts**—**Residual Asphalts**—Processes Used—Physical and Chemical Characteristics—Methods of Distinguishing Between Petroleum Asphalts and Native Asphalts—**Sludge Asphalts**—Methods of Production—Physical and Chemical Characteristics.

CHAPTER XX

PARAFFINE WAX AND WAX TAILINGS	307
--	-----

Paraffine Wax—Sources from which Obtained—Methods of Production—Refining Processes—Physical and Chemical Characteristics—**Wax Tailings**—Methods of Production—Physical and Chemical Characteristics.

CHAPTER XXI

WURTZILITE ASPHALT	313
------------------------------	-----

Method of Production—Still Used—Depolymerization Process—Grades of Wurtzilite Asphalt Produced—Chemical and Physical Characteristics.

CHAPTER XXII

FATTY-ACID PITCH, BONE TAR AND BONE-TAR PITCH	317
---	-----

Fatty-Acid Pitch—Sources from which Obtained—*Production of Candle and Soap Stocks*—Hydrolysis by Means of Water—Hydrolysis by Means of Concentrated Sulphuric Acid—Hydrolysis by the “Mixed Process” Hydrolysis by Means of the Sulpho-Compounds—Hydrolysis by Means of Ferments—*Refining Vegetable Oils by Means of Alkali*—Refining of Cotton-Seed Oil—Refining of Corn-

Oil—*Refining Refuse Greases*—Refining Packing-House and Carcass-Rendering Greases—Refining Bone Grease—Refining Garbage and Sewage Greases—Refining Woolen-Mill Waste—*Treatment of Wool Grease—Physical and Chemical Properties of Fatty-Acid Pitches*—**Bone Tar and Bone-Tar Pitch**—Methods of Production—Physical and Chemical Characteristics.

PART IV.—MANUFACTURED PRODUCTS AND THEIR USES

CHAPTER XXIII

METHODS OF BLENDING 338

Hardness, Fusibility, Approximate Comparative Volatility, Weatherproof Properties and Efficiency of Fluxing of Various Bituminous Substances—Principles Involved in Preparing Mixtures—*Binary Mixtures*—Softening of the Substance and Lowering its Fusing-Point—Hardening the Substance and Raising its Fusing-Point—Rendering the Mixture Less Susceptible to Temperature Changes—Effecting a More Perfect Union or Blending of the Constituents—Making the Mixture more Weatherproof—Increasing the Tensile Strength of the Mixture—Rendering Wax-Like, Unctuous to the Feel, or Lessening the Tendency towards Stickiness—*Tertiary and Complex Mixtures*—*Classes of Bituminous Mixtures*—Soft (Liquid) bituminous products—Medium (Semi-solid) Bituminous Products—Hard (Solid) Bituminous Products—*Processes of Blending Bituminous Substances*—Apparatus for Incorporating Fillers—Emulsification.

CHAPTER XXIV

BITUMINOUS PAVING MATERIALS 352

Bituminous Dust-Laying Oils—Bituminous Materials Used—Bituminous Emulsions—Non-Emulsified Products—General Considerations—Methods of Use—*Bituminous Surfacing*—Bituminous Binder—Mineral Aggregate—Preparing and Applying the Surfacing—General Considerations—*Bituminous Macadam*—Foundation Course—Mineral Aggregate—Bituminous Binder—Preparing and Applying the Surface Course—*Bituminous Concrete Pavements*—Foundation or Base Course—Mineral Aggregate—Bituminous Cement or Binder—Preparing and Applying the Mixture—General Considerations—*Sheet Asphalt Pavements*—Foundation or Base Course—Intermediate or Binder Course—Surface or Wearing Course—Asphaltic Cement—Preparing and Applying the Wearing or Surface Course—*Asphalt Block Pavements*—Foundation or Base—Laying the Blocks—*Asphalt Mastic Foot-Pavements and Floors*—Asphalts Used—Methods of Preparation—Methods of Laying—*Bituminized Wood-Block Pavements*—Methods of Impregnation—Creosote Preservatives—Foundation Course—Cushion Layer—Filling the Joints—General Considerations—*Bituminous Fillers for Wood, Brick and Stone Pavements*—Characteristics of Bituminous Materials Used—Filling the Joints—*Bituminous Expansion Joints*—Premoulded Strips—Bituminized Fabric Strips—Armored Bituminized Fabrics.

CHAPTER XXV

	PAGE
BITUMINIZED FABRICS FOR ROOFING, FLOORING, WATERPROOFING SHEATHING AND INSULATING PURPOSES.....	386

Sheet Roofings—Felted Fabrics—Woven Fabrics—Bituminous Saturating Compositions—Bituminous Coating and Adhesive Compositions—Surfacings of Mineral Matter—Surfacings of Vegetable Matter—Saturating the Fabric—Single-layered Prepared Roofings—Laminated Prepared Roofings—Roll Roofings Finished with an Ornamental Surface—Prepared Roofing Shingles—Fastening Devices—Methods of Forming Roll Roofing Packages—Methods of Laying Prepared Roofings and Shingles—Rating of Prepared Roofings and Shingles by the Underwriters Laboratories, Inc.—**Bituminized Floor Coverings**—Methods of Manufacture—Methods of Printing and Graining—**Waterproofing Membranes**—Materials Used—Preparing the Underlying Surface—Selecting and Installing the Waterproofing Membrane—Protecting the Waterproofing Membrane—**Insulating and Sheathing Papers**—Raw Paper Stock—Bituminous Saturation—Bituminous Coating Compositions—Method of Manufacture—Efficiency of the Paper—Saturated and Coated Papers for Electrical Insulation—**Electrical Insulating Tape**—Characteristics of the Bituminous Impregnation—**Bituminized Wall Board**—Method of Manufacture

CHAPTER XXVI

SEMI-LIQUID, SEMI-SOLID AND SOLID BITUMINIOUS COMPOSITIONS. . . .	442
---	-----

Adhesive Compounds for Built-Up Roofing and Waterproofing Work—Adhesive Compounds for Membrane Waterproofing Underground—Adhesive Compounds for Membrane Waterproofing Above Ground—Adhesive Compounds for Built-Up Roofing Work—*Pipe Dips and Pipe-Sealing Compounds*—Pipe Dips—Pipe-Sealing Compounds—*Electrical Insulating Compounds*—Insulation for Cotton-Covered Transmission Wires—Vacuum Impregnating Compounds—Junction-box and Pot-head Compounds—Battery-box Compounds—“Carbons” for Batteries, Electric Lights and Armature Brushes—*Bituminous Rubber Substitutes*—*Moulding Compositions*—Mixtures for Small Moulded Articles—Preformed Joints and Washers—Bituminated Cork Mixtures—Bituminated Leather Mixtures—Briquette Binders—Core Compounds—*Miscellaneous Bituminous Products*—Bituminous Fuels—Tars and Oils for the Flotation of Ores—Wood Preservatives—*Waterproofing Compounds for Portland-Cement Mortar and Concrete*—Pure Bituminous Materials—Bituminous Materials in Emulsified Form—Methods of Use.

CHAPTER XXVII

BITUMINOUS PAINTS, CEMENTS, VARNISHES, ENAMELS, AND JAPANS	462
--	-----

Bituminous Paints—Nature of the Base Used—Nature of the Fillers and Pigments Used—Nature of the Solvents Used—*Methods of Manufacture*—*Types of*

Bituminous Paints—Masonry Paints—Paints for Recoating Prepared Roofings—
 Bituminous Paints for Metal or Wood—**Bituminous Cements**—Method of Preparation—
 Method of Use—**Bituminous Varnishes**—Method of Manufacture—**Bitu-
 minous Enamels**—Method of Manufacture—**Bituminous Japans**—Method of
 Preparation and Use.

PART V.—METHODS OF TESTING

CHAPTER XXVIII

PHYSICAL CHARACTERISTICS 480

Synoptical Table of Bituminous Substances—*Color in Mass*—*Homogeneity*—
 To the Eye at 77° F.—Under Microscope—When Melted—*Appearance Surface
 Aged Indoors One Week*—*Fracture*—*Lustre*—*Streak on Porcelain*—*Specific Gravity*—
 Hydrometer Method for Fluid Materials—Westphal Balance Method—Pycnometer
 Method—Sommer Hydrometer Method—Hubbard Pycnometer Method—Weiss'
 Specific Gravity Pan Method—*Viscosity*—Engler Method—Hutchinson's Tar
 Tester—Hubbard's Consistency Tester—Float Test—Schutte Consistency Tester
 —*Hardness or Consistency*—Moh's Hardness Scale—Needle Penetrometer—
 Consistometer—Susceptibility Factor—*Ductility*—Dow Ductility Test—Author's
 Ductility Test—*Tensile Strength*—*Adhesiveness Test*—Osborne Adhesive Test—
 Kirschbraun Adhesive Test.

CHAPTER XXIX

HEAT TESTS 509

Odor on Heating—*Subjection to Heat*—Behavior on Melting—Behavior on
 Heating in Flame—*Fusing* ("Melting-Point")—Kramer-Sarnow Method—Ball
 and Ring Method—Cube Method—Flowing Temperature—*Volatile Matter*—
Flash-Point—Pensky-Martens Closed Tester—Cleveland Open Tester—New York
 State or Elliot Closed Tester—*Burning-Point*—*Fixed Carbon*—*Distillation Test*—
 Flask Method of Distillation—Retort Method of Distillation.

CHAPTER XXX

SOLUBILITY TESTS 524

Solubility in Carbon Disulphide—Soluble in Carbon Disulphide—Non-Mineral
 Matter Insoluble in Carbon Disulphide—Mineral Matter—*Carbenes*—*Solubility
 in 88° Petroleum Naphtha*—*Solubility in Other Solvents*.

CHAPTER XXXI

	PAGE
CHEMICAL TESTS	529

Water—Substances Distilling at Low Temperatures—Substances Distilling at High Temperatures—*Carbon*—*Hydrogen*—*Sulphur*—*Nitrogen*—*Oxygen*—*Free Carbon in Tars*—*Naphthalene in Tars*—*Solid Paraffines*—*Saturated Hydrocarbons*—*Sulphonation Residue*—*Mineral Matter*—Uncombined Mineral Matter—Mineral Matter Combined with Non-Mineral Constituents—Chemical Analysis of Mineral Matter—Microscopic Examination—Granularmetric Analysis—Specific Gravity of Mineral Matter—*Saponifiable Constituents*—Free Acids (Acid Value)—Lactones and Anhydrides (Lactone Value)—Neutral Fats (Ester Value)—Saponification Value—Estimation of Fatty and Resin Acids—*Asphaltic Constituents*—Free Asphaltous Acids—Asphaltous Acid Anhydrides—Asphaltenes—Asphaltic Resins—Oily Constituents—*Estimation of Unsaponifiable and Saponifiable Matters*—Hydrocarbons—Higher Alcohols (Cholesterol)—*Glycerol*—*Diazo Reaction*—*Anthraquinone Reaction*—*Liebermann-Storch Reaction*.

CHAPTER XXXII

METHODS OF TESTING MANUFACTURED PRODUCTS	552
--	-----

Bituminized Mineral Aggregates—Effect of Moisture—Tensile Strength—Compressive Strength—Transverse Strength—Impact Test—Distortion under Heat—Softening-point—Separation of the Bituminous Matter and Mineral Aggregate—Forrest's Hot Extraction Method—Centrifugal Method—Recovery of Extracted Bituminous Matter—Examination of the Recovered Mineral Aggregate. Bituminized Fabrics—*Physical Tests of the Finished Fabric*—Pliability Tests—Heating Tests—*Separating Prepared Roofing into Its Component Parts*—Mineral Matter—Bituminous Matter—Fibrous Matter—*Testing the Raw Felt*—Ash—Fibres Present—Number—Thickness—Mullen Strength—*Testing the Raw Burlap or Duck*—Weight—Thickness—Strength—*Testing the Bituminous Compounds*—*Examining the Mineral Ingredients*—**Bituminous Emulsions**—**Bituminous Paints, Cements, Varnishes and Japans**—*Estimation of Solvent*—*Pigment and Filler*—*Examining of the Base*—Analyzing the Base—Examining Dry Paint Films.

CHAPTER XXXIII

WEATHERING TESTS	574
----------------------------	-----

Effects of Weathering—Evaporation—Oxidation—Carbonization—Polymerization—Effects of Moisture—*Conducting Weathering Tests on Bituminized Fabrics*—*Conducting Weathering Tests on Bituminous Paints*.

ILLUSTRATIONS

FIG.	PAGE
1. Statue of Lugal-daudu, King of Adab (3000 B.C.) Showing Eye-sockets Lined with Asphalt.	2 <i>Frontispiece</i>
2. Human-Headed Bull (3000 B.C.) with Shells Inlaid in Asphalt.	2
3. Heraldic Device of Lagash (2850 B.C.) Case in Asphalt.	3
4. Bust of Manishtusu, King of Kish (2600 B.C.) with Eyes Set in Asphalt.	4
5. Libation Vase Dedicated to Gudea, Ruler of Lagash (2500 B.C.) Showing Shells Set in Asphalt.	5
6. Early Persian Sculpture with Eyes Set in Asphalt.	5
7. Persian Vases Hewn from Blocks of Asphalt.	6
8. Primitive Animal Carved from Asphalt.	6
9. Asphalt Spring in Mesopotamia.	9
10. Floor of Nebuchadnezzar's Temple as it Appears To-day, Showing Blocks Joined by Means of Asphalt.	10
11. Trilinear Coordinates on an Equilateral Triangle.	43
12. Trilinear Coordinates on an Isosceles Triangle.	43
13. Percentages of Carbon, Hydrogen and Oxygen in Typical Bituminous Substances.	44
14. Asphalt Spring.	49
15. Asphalt Lake.	49
16. Asphalt Seepage.	49
17. Subterranean Pool or Reservoir.	49
18. Asphalt-Impregnated Horizontal Strata.	49
19. Asphalt-Impregnated Strata in Thrust.	49
20. Fault Filling Caused by Cleavage.	49
21. Fault Filling Caused by Upturning.	49
22. Vein Filling Caused by Sliding of Strata.	49
23. Veins Formed by Sedimentation.	49
24. Production of Asphalts and Asphaltites in the U. S. from 1880 to 1916.	65
25. Steel Melting Tank.	69
26. Apparatus for Separating Soft Asphalt from Sand by Means of Water.	72
27. Looking into the Top of the Extracting Apparatus.	73
28. View of Bermudez Asphalt Lake.	87
29. Transporting Bermudez Asphalt.	87
30. Map of Asphalt Region in Oklahoma.	94
31. Sand Asphalt Quarries in Santa Cruz County, Cal.	103
32. Sand Asphalt Quarries in Santa Cruz County, Cal.	104
33. Asphaltic Sand on the Shore at Carpenteria, Cal.	105
34. Asphaltic Sand on Banks of Athabaska River, Alberta, Can.	106

FIG.	PAGE
35. Map of Trinidad Asphalt Lake	109
36. Panoramic View of Trinidad Lake	110
37. Folds in the Surface of Trinidad Lake	111
38. Evolution of Gas from Trinidad Lake	111
39. Gathering Trinidad Lake Asphalt	112
40. Transporting Trinidad Lake Asphalt	112
41. Map of Seyssel Asphalt Deposit, France	117
42. Map of Neuchatel (Val-de-Travers) Asphalt Region, Switzerland	118
43. Map of Lobsann Asphalt Region, Alsace-Lorraine	119
44. Cross-Section of Limmer Asphalt Deposit Germany	120
45. Chart of Physical Characteristics of Fluxed Gilsonite Mixture	129
46. Faults in Gilsonite Vein	130
47. Map of Gilsonite Region, Utah	131
48. View of Cowboy Gilsonite Mine, Utah	132
49. Vertical Section through Dead Sea Showing Glance Pitch Veins	136
50. View of Grahamite Vein, Ritchie County, W. Va.	138
51. Sections through Grahamite Mine, Ritchie County, W. Va.	139
52. Vertical Section through Grahamite Mine near Tuskahoma, Okla.	140
53. Chart of Physical Characteristics of Fluxed Oklahoma Grahamite Mixture	141
54. Chart of Physical Characteristics of Fluxed Trinidad Grahamite Mixture	148
55. View of Wurtzilite Mine, Uinta County, Utah	151
56. Transporting Wurtzilite from the Mine	152
57. Vertical Section through Wurtzilite Vein, Uinta County, Utah	152
58. Hydraulic Main	174
59. Air Condenser	175
60. Water Condenser	175
61. Rain Scrubber	176
62. Hurdle Scrubber Filled with Coke	176
63. Hurdle Scrubber Filled with Wooden Slats	176
64. Baffle Scrubber	176
65. Feld Centrifugal Scrubber	177
66. Reading Centrifugal Scrubber	177
67. Thiesen Centrifugal Scrubber	178
68. Schwarz-Bayer Disintegrator	179
69. P. & A. Tar Extractor	179
70. Centrifugal Deflector	179
71. Smith Tar Extractor	179
72. Cottrell Electrical Precipitator	180
73. Baffle-Plate Tar Separator	181
74. Centrifugal Tar Dehydrator	182
75. Iron Cars Used in the Distillation of Hardwood	186
76. Modern Wood Distilling Plant	187
77. Plant for Refining Wood Tar	187
78. Retorts for Distilling Soft Wood	189
79. Retort for Distilling Rosin	193
80. Körting Double-Zone Up-Draft Gas Producer for Peat	202
81. Retort for Distilling Pure Lignite	206
82. Retort for Distilling Impure Lignite	208

FIG.	PAGE
83. Young & Beilby Retort for Distilling Shales	217
84. Pumpherston Retort for Distilling Shales	218
85. Henderson Retort for Distilling Shales	219
86. Horizontal Gas-Works Retort	228
87. Inclined Gas-Works Retort	229
88. Vertical Gas-Works Retort	230
89. Semet-Solvay Coke Oven	235
90. Otto-Hoffman Coke Oven	236
91. United-Otto Coke Oven	237
92. Koppers Coke Oven	237
93. Blast-Furnace Dust Catcher	238
94. Fairbanks-Morse Suction Gas-Producer, Type 1	241
95. Loomis-Pettibone Section Gas-Producer, Type 2	241
96. Westinghouse Gas-Producer, Type 3	242
97. Horizontal Still for Refining Coal Tar	247
98. Vertical Still for Refining Coal Tar	247
99. Feld System for Fractioning Coal Tar	249
100. Chart of Physical Characteristics of Coal-Tar Pitch	254
101. Lowe Water-Gas Plant	256
102. Pintsch Gas Retort	260
103. Oil-Water Gas Plant	260
104. Plant for Dehydrating Petroleum	270
105. Horizontal Petroleum Stills	271
106. Plant for Refining Petroleum	272
107. Tower System for Distilling Petroleum	273
108. Topping Plant for Refining Petroleum	275
109. Livingston Apparatus for Continuous Distillation of Petroleum	276
110. Effect of Blowing on the Fusing-Point and Hardness of Petroleum Asphalt	290
111. Chart of Physical Characteristics of Blown Petroleum Asphalt	291
112. Relation between the Specific Gravity and Fusing-point of Residual Oils, Blown Petroleum Asphalts and Residual Asphalts	293
113. Chart of Physical Characteristics of D-Grade California Asphalt	302
114. Apparatus for the Acid-Purification of Petroleum Distillates	303
115. Paraffine Wax Sweater	308
116. Mixer for Incorporating Large Percentages of Fillers in Asphalt	351
117. Mixer for Preparing Paving Compositions	372
118. Tools for Finishing Mastic Floors	376
119. Machine for Manufacturing Roofing Felt	387
120. Tar Saturator	396
121. Asphalt Saturator	396
122. Prepared Roofing Finished in a Veined Surface	400
123. Prepared Roofing Finished with Coarse Talc	400
124. Prepared Roofing Finished with Fine Sand	400
125. Prepared Roofing Finished with Crushed Slate	400
126. Prepared Roofing Finished with Crushed Feldspar	400
127. Prepared Roofing Finished with Pebbles	400
128. Coating Machine Used in the Intermittent Process of Manufacturing Roofing	404
129. Continuously Operating Machine for Manufacturing Prepared Roofing	404

FIG.	PAGE
130. Device for Applying Mineral Particles to the Surface of Prepared Roofing	406
131. Winding Mechanism	406
132. High-Speed Continuously Operating Machine for Manufacturing Prepared Roofing	407
133. Machine for Assembling Multiple-Layered Bituminized Fabrics	410
134. Roll Roofings Finished in an Ornamental Surface	411
135. Shingle Cutter (Front View)	413
136. Shingle Cutter (Rear View)	413
137. Wide-Spaced Shingles	414
138. Multiple Shingle Strip	414
139. Diamond Shingle Strip	415
140. Reversible Shingle Strip	415
141. Types of Roofing "Cleats"	417
142. Wire Roofing Fastener	417
143. Laying Roll Roofing in Single Course	419
144. Two-Ply Built-Up Roofs over Wood and Concrete	420
145. Three-Ply Built-Up Roofs over Wood and Concrete	421
146. Five-Ply Built-Up Roofs over Wood and Concrete	422
147. Laying Individual Shingles	423
148. Chart of Annual Production of Roofings in the U. S.	425
149. Vacuum Impregnating Apparatus	450
150. Preformed Washers for Skylights	453
151. Varnish Kettle	468
152. Paint Grinding Mill	469
153. Hydrometer	486
154. Westphal Balance	487
155. Sommer Hydrometer	490
156. Hubbard Pycnometer	490
157. Weiss' Specific Gravity Pan	490
158. Engler Viscosimeter	491
159. Hutchinson's Tar Tester	492
160. Hubbard's Consistency Tester	492
161. Float Tester	493
162. Schutte Viscosity Tester	494
163. Needle Penetrometer	496
164. Miniature Penetrometer	496
165. Consistometer	499
166. Dow Ductility Mould	502
167. Smith Ductility Tester	503
168. Author's Ductility Mould	503
169. Cross-Section Author's Mould	504
170. Tensometer	505
171. Osborne Adhesive Tester	507
172. Kirschbraun Adhesive Tester	507
173. Method of Filling K. and S. Fusing-point Tubes	511
174. Heating Coil for K. and S. Fusing-point Tester	511
175. K. and S. Fusing-point Tester	512
176. K. and S. Tester for Hig ^b Fusing-point Substances	514

FIG.	PAGE
177. B. and R. Fusing-Point Tester	514
178. Cube Fusing-Point Tester	515
179. Cube Tester for High Fusing-Point Substances	515
180. Shelf for Volatility Oven	517
181. Volatility Oven	518
182. Pensky-Martens Closed Flash-Point Tester	518
183. Cleveland Open Flash-Point Tester	519
184. New York State Closed Flash-Point Tester	519
185. Flask Method of Distillation	521
186. Asbestos Shield for Retort	522
187. Retort Method of Distillation	523
188. Still for Determining Water	529
189. Combustion Furnace for Ultimate Analysis	531
190. Cary-Curr Extraction Apparatus	535
191. Bureau of Standards' Modification of Le Chatelier's Specific Gravity Flask	541
192. Goldbeck's Specific Gravity Apparatus	542
193. Mould for Ascertaining the Tensile Strength of Bituminized Aggregates	553
194. Apparatus for Recording Distortion of Bituminized Aggregates under Heat	556
195. Apparatus for Determining the Softening-Point of Bituminized Aggregates	557
196. Forrest's Hot-Extraction Apparatus	558
197. Centrifugal Extractor	558
198. Mechanical Sifting Apparatus	559
199. Types of Prepared Roofings	561
200. Mandrels for Testing the Pliability of Prepared Roofings	561
201. Tensile Strength Specimen	562
202. Instrument for Testing the Tensile Strength of Prepared Roofings	562
203. Method of Stripping the Coatings from the Saturated Felt	566
204. Method of Removing the Coatings	566
205. Exposure-Test Card	577
206. Effects of Exposure on Smooth-Surfaced Prepared Roofings	579
207. Enlargements of Specimens A and H in Fig. 206	580
208. Tensile Strength Curves of Prepared Roofings on Exposure	581

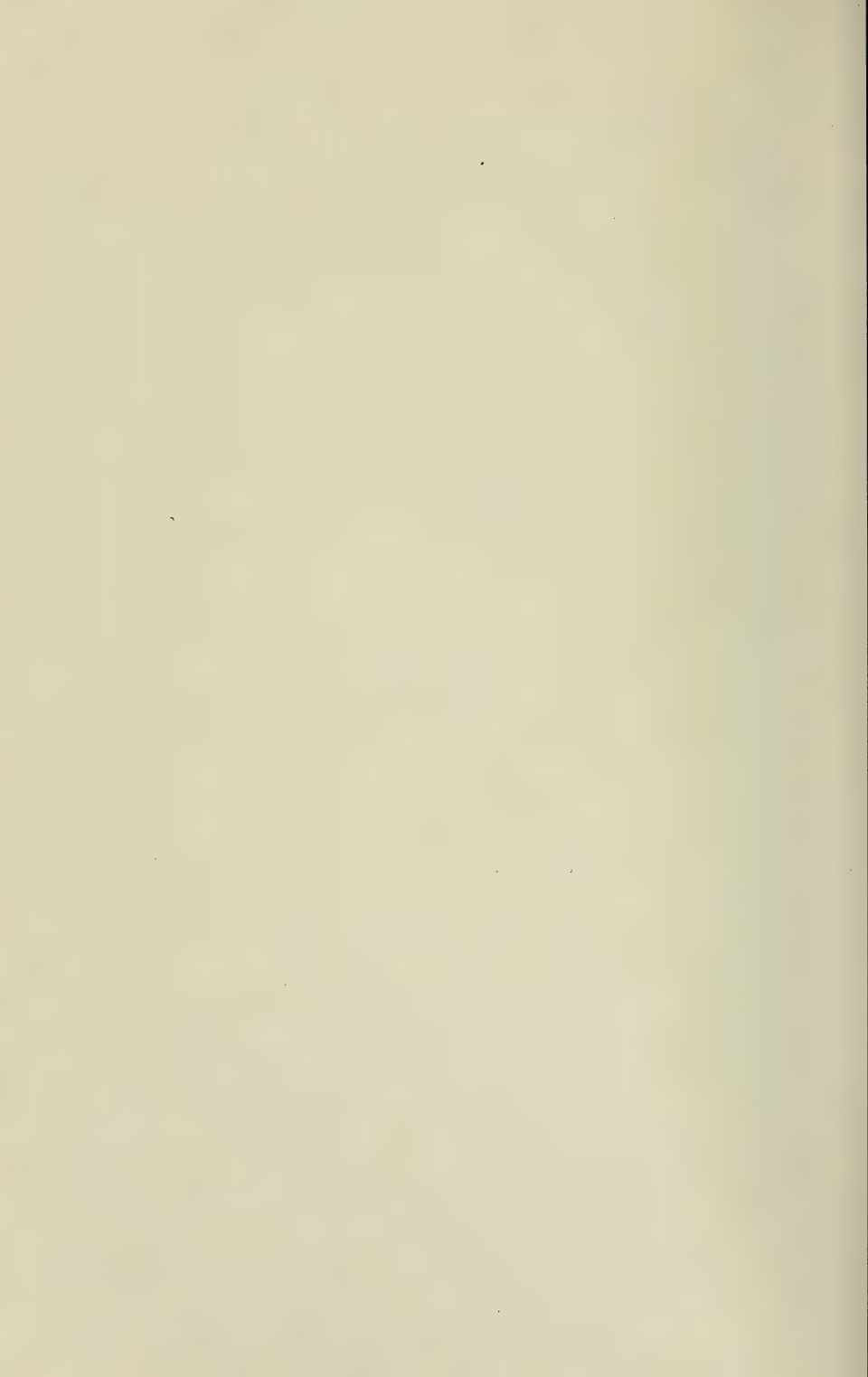

ASPHALTS AND ALLIED SUBSTANCES

PART I

GENERAL CONSIDERATIONS

CHAPTER I

HISTORICAL REVIEW

Origin of the Words "Asphalt" and "Bitumen." The term "asphalt" may be traced back to Babylonian times. It was later adopted by the Homeric Greeks in the form of the adjective ἀσφαλής, ἔς, signifying "firm," "stable," "secure," and the corresponding verb ἀσφαλιζω, ἴσω, meaning "to make firm or stable," "to secure." It is a significant fact that the first use of asphalt by the ancients was in the nature of a cement for securing or joining together various objects, and it thus seems likely that the name itself was expressive of this application. From the Greek, the word passed into late Latin, and thence into French ("asphalte") and English ("asphalt").

The expression "bitumen" originated in the Sanskrit, where we find the word "jatu-krit," meaning "pitch creating," "pitch producing" (referring to coniferous or resinous trees). The Latin equivalent is claimed by some to be "gwitû-men" (pertaining to pitch), and by others, "pictumens" (exuding or bubbling pitch), which was subsequently shortened to "bitûmen," thence passing via French into English.

Use of Asphalt by the Sumerians (about 3000 to 2500 B.C.) The earliest recorded use of asphalt by the human race was by the pre-Babylonian inhabitants of the Euphrates Valley. These people, known as Sumerians, were skilled in carving and decorating stone, as evidenced by the varied and interesting specimens of pottery and statuary unearthed

in recent years. In certain of these we find shells or bits of stone cemented in place by means of asphalt.

In 1903-4, Dr. E. J. Banks, while excavating at Adab (known also as Bismya) between the Euphrates and Tigris Rivers in Syria, discovered a marble statue of Lugal-daudu, King of Adab (Fig. 1), one of the early Sumerian rulers, who lived about 3000 B.C.¹ An inscription reveals the name of the city of Adab. The eye-sockets are hollow, and still show the presence of asphalt, indicating that they were once inlaid with some substance, probably ivory or mother-of-pearl. The statue is now on exhibition at the Ottoman Museum in Constantinople.²



From "The Civilization of Babylonia and Assyria," J. B. Lippincott Co.

FIG. 2.—Human-Headed Bull (3000 B.C.) with Shells Inlaid in Asphalt.

Another statute (Fig. 2) originating about the same time (3000 B.C.) known as the "Human Headed Bull," is composed of black steatite, inlaid with small yellow shells imitating streaks, and held in place with asphalt. Many of the shells are intact, gripped firmly by the asphalt throughout fifty centuries of time and exposure, thus furnishing evidence of its remarkable adhesiveness and durability. This statue is now at the Louvre, Paris.³

¹ "The Civilization of Babylonia and Assyria," by Morris Jastrow Jr., pp. 394-5. J. B. Lippincott Co, Phila., 1915.

² "Bismya," by E. J. Banks, p. 191.

³ Fondation Eugène Piot, "Monuments et Mémoires," by Ernest Leroux Paris Vol. VI, 1899; also Vol. VII, 1900.

An interesting specimen of Sumerian art was excavated at Lagash, near the mouth of the Euphrates, consisting of a sculptured votive offering dating back to Eutemena, ruler or so-called "Patesi" of Shirpula (2850 B.C.). This bears as an inscription, the heraldic device of Lagash, by means of which we are enabled to fix its date and origin. The tablet is an artificial composition of clay and asphalt (Fig. 3). It is also on exhibition at the Louvre.¹

The bust of an early Sumerian ruler, Manishtusu, King of Kish (about 2600 B.C.) was found in the course of excavations at Susa, in Persia, whence it is supposed to have been carried by an Elamite conqueror in the twelfth century B.C.² In describing



From "The Civilization of Babylonia and Assyria," J. B. Lippincott Co.

FIG. 3.—Heraldic Device of Lagash (2850 B.C.) Cast in Asphalt.

this statue, M. de Morgan states: "the eyes, composed of white limestone, once ornamented with black pupils now fallen off, are held in their orbits with the aid of *bitumen*; the face appears rough; the beard and hair are of conventional design; as regards the inscription, it is engraved in lineal cuneiform characters of the most ancient style." (Fig. 4.) The original is at the Louvre.

Another relic, known as the "Libation Vase" (Fig. 5) is composed of green steatite, carved in the form of strange mythical monsters, the effect of which is heightened by incrustated little shells set in asphalt, to represent the scaly backs of

¹ Fondation Eugène Piot, "Monuments et Mémoires," by Ernest Leroux, Paris, Vol. I, 1894.

² "Mémoires de la Délégation en Perse," published under the direction of M. de Morgan, Vol. II, 1900, Plate IX; Vol. X, 1908, Plate I, published by Ernest Leroux, Paris; also *Comptes Rendus de l'Académie d'Inscriptions*, July 1907, pp. 398-9, Figs. 1 and 2, by M. de Morgan.

winged serpents. The serpent was supposed to represent the emblem of the god Ningishzida, to whom the accompanying inscription shows the vase to be dedicated by Gudea, ruler or Patesi of Lagash (2500 B.C.). This is considered one of the best specimens of Sumerian sculpture, and represents the height of Sumerian art. It is also at the Louvre.¹



From "The Civilization of Babylonia and Assyria," J. B. Lippincott Co.
 FIG. 4.—Bust of Manishtusu, King of Kish (2600 B.C.) with Eyes Set in Asphalt.

Use of Asphalt by the Early Persians (about 2800 to 2500 B.C.). A number of specimens of Persian sculpture involving the use of asphalt were excavated at Susa in the province of Susiana, Persia, by M. J. de Morgan's expedition of Paris.² These are in an excellent state of preser-

¹ "Découvertes en Chaldée"; also "Catalogue des Antiquités Chaldéennes du Musée National du Louvre," by Henzey, Paris, 1902, No. 125.

² "Mémoires—Délégation en Perse," published under the direction of J. de Morgan, Vol. XIII, "Recherches Archéologiques Cinquième Série de l'Epoque Archaïque," by Edm. Pottier, published by Ernest Leroux, Paris, 1912.

vation, and by the inscriptions and characteristic ornamentation are supposed to have originated between 2800 and 2500 B.C.

Fig. 6 shows various small animals carved of alabaster having the eyes cemented in place with asphalt; Fig. 7, two decorated vases composed wholly of asphalt; and Fig. 8, a sculpture of an animal in primitive form, hewn from a mass of asphalt. The French chemist, Henry Le Chatelier, analyzed some of the asphalt, and found it to consist of the following:¹

Moisture, 2.8 per cent; asphalt, 24.4 per cent; wax, 1.6 per cent; mineral matter, 71.2 per cent. The mineral matter was composed of: calcium carbonate, 45.2 per cent; calcium sulphate, 3.5 per cent; calcium phosphate, 0.8 per cent; iron, aluminium and silicon oxides, 21.7 per cent.

This is conclusive proof that the asphalt is a natural product composed of 25 per cent asphalt and 75 per cent mineral matter, similar to the material obtained in the locality at the present day. (See p. 126.)

Use of Asphalt by the Early Egyptians (about 2500 B.C.). The ancient Egyptians

used asphalt for preserving their dead rulers, by wrapping the bodies in cloth and coating them with liquid or melted asphalt. The remains are known as "mummies," and at one period this word was syn-



From "The Civilization of Babylonia and Assyria," J. B. Lippincott Co.

FIG. 5.—Libation Vase Dedicated to Gudea, Ruler of Lagash (2500 B.C.), Showing Shells Set in Asphalt.

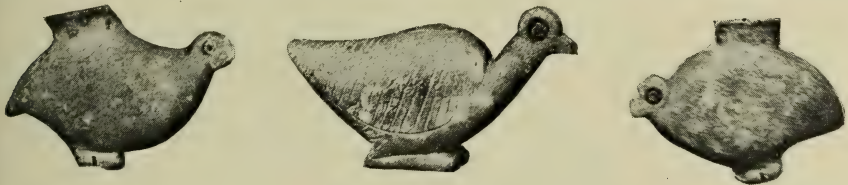

From "Mémoires de la Délégation en Perse," by Edm. Pottier.

FIG. 6.—Early Persian Sculpture with Eyes Set in Asphalt.

onymous with "asphalt." The oldest mummies in existence concerning which we have authentic data, date back to the Sixth Egyptian Dynasty (about 2500 B.C.). The oldest specimens include the mummy of Seker-em-sa-f, unearthed at Sakkarah in 1881, and exhibited at Gîza, near Cairo,² and the mummy of King Merenrē, now at the Boulak Museum, Cairo.³

¹ "Mémoires," Vol. XIII, p. 162.

² "The Mummy," by E. A. Wallis Budge, pp. 184, Cambridge University Press, 1893.

³ "Natural Rock Asphalts and Bitumens," by Arthur Danby, pp. 41, New York, 1913.

Use of Asphalt in Biblical Times (2500 to 1500 B.C.). Some contend that Noah used asphalt in the construction of the Ark (Genesis VI, 14).



From "Mémoires de la Délégation en Perse," by Edm. Pottier.

FIG. 7.—Persian Vases Hewn from Blocks of Asphalt.

The Biblical text reads, that it was treated with "pitch" within and without: "bituminabis eam bituminæ" (Vulgate). There is some doubt as to whether this referred to asphalt, as pine pitch was known at the time, and might very well have been used for this purpose. If asphalt was actually used, the date would be fixed at approximately 2500 B.C., which is usually assigned to the Deluge.

to what we now know to be asphalt. The Book of Genesis (XI, 3) in describing the building of the Tower of Babel (about 2000 B.C.) states. . . . "and they had brick for stone, and *slime* had they for mortar." There seems to be no question but that the so-called "slime" alludes to asphalt, since the word translated as "slime" in the English version, occurs as *ἀσφαλτος* in the Septuagint, and as "bitumen" in the Vulgate. In Genesis (XIV, 10) we are informed that the Vale of Siddim "was

We find numerous other references in the scriptures to substances corresponding



From "Mémoires de la Délégation en Perse," by Edm. Pottier.

FIG. 8.—Primitive Animal Carved from Asphalt.

full of *slimepits*," referring no doubt to exudations of liquid asphalt. Moreover, it is pointed out by certain authorities that the area described as the Vale of Siddim corresponds to our present Dead Sea, from which asphalt is still obtained. (See p. 135.)

Again we are told (Exodus II, 3) that in constructing the basket of bulrushes in which Moses was placed, it was daubed "with *slime* and with *pitch*." This took place about 1500 B.C. ("Septuaginta Interpretes," Tischendorf).

Use of Asphalt by the Babylonians (700 to 500 B.C.). The Babylonians were well versed in the art of building, and each monarch commemorated

his reign and perpetuated his name by constructing some vast engineering work. Certain kings built roadways, others built retaining walls to impound the waters of the Euphrates, and still others mighty battlements and palaces. The facts were indelibly recorded by inscriptions on the bricks used for the purpose, many of which are still in existence.

The following inscription occurring on the bricks of the so-called "Sargeon Wall" of Babylon, built by King Sargeon who ruled 710 to 705 B.C., has been translated by Delitzsch: ¹

"To Marduk, the Great Lord, the divine Creator, who inhabits Esagila, the Lord of Babil, his lord Sargeon, the mighty king, King of the land of Assur, King of all, governor of Babil, King of Sumer and Akkad, the nourisher of Esagila and Ezida. To build Imurg-Bel was his desire; he caused burnt brick of pure Kirû (?) to be struck, built a kâr (?) with tar and asphalt on the side of the Ishtar Gate to the bank of the Euphrates in the depth of the water, and founded Imgur-Bel and Nimitti-Bel mountain high, firm upon it. This work may Marduk, the great Lord, graciously behold, and grant Sargeon, the prince who cherishes him, life! Like the foundation stone of the Sacred City, may the years of his reign endure."

This revealed the use of asphalt as a cement for joining together bricks. Modern excavations indicate that this method was used quite generally, as will be described in greater detail later. "Imgur-Bel" was the name given to the inner wall of Babylon, and "Nimitti-Bel" to the outer.

Of all the Babylonian rulers, Nebuchadnezzar, who reigned 604 to 561 B.C., was the most progressive, and is stated to have reconstructed the entire city. The bricks bore inscriptions relating to his work, and several refer specifically to the use of asphalt. One found in the so-called "Procession Street" which led from his palace to the North wall, reads as follows (Translation by Weissbach, Koldewey, p. 54):

"Nebuchadnezzar, King of Babylon, he who made Esagila and Ezida glorious, son of Nabopolassar, King of Babylon. The streets of Babylon, the Procession Street of Nabû and Marduk, my lords, which Nabopolassar, King of Babylon, the father who begot me, had made a road glistening with asphalt and burnt bricks; I, the wise suppliant who fears their lordships, placed above the bitumen and burnt bricks, a mighty superstructure of shining dust, made them strong within with bitumen and burnt bricks as a high-lying road. Nabû and Marduk, when you traverse these streets in joy, may benefits for me rest upon your lips; life for distant days, and well-being for the body. Before you I will advance upon them. May I attain eternal age!"

This would seem to be the forerunner of the present-day pavement composed of stone blocks set in asphalt. It seems strange that the art should have become lost to mankind, only to be rediscovered in the nineteenth century A.D. According to Nebuchadnezzar, his father, Nabopolassar (625-604 B.C.) is credited to have laid the first asphalt block pavement of which we have any record.

The most comprehensive relic left by Nebuchadnezzar is known as the "Large Inscribed Stone Tablet" (sometimes referred to as the "East India House Inscript-

¹"The Excavations at Babylon," by Robert Koldewey, pp. 138, Macmillan & Co., Ltd., London, 1914.

tion"), which contains a detailed account of his building activities. A translation by Delitzsch reads in part as follows (Column 7, lines 34 *et seq.*):

"In Babil, my favorite city that I love, was the palace, the house, the marvel of mankind, the center of the land, the dwelling of majesty, upon the Babil place in Babil, from Ingur-Bel to the eastern canal Libil-Higalla; from the bank of the Euphrates to Aibursabu, which Nabopolassar, King of Babylon, my father, my begetter, built of *crude bricks*, and dwelt in it. In consequence of high waters, its foundations had become weak, and owing to the filling up of the streets of Babil, the gateway of that palace had become too low. I tore down its walls of *dried brick*, and laid its corner-stone bare, and reached the depth of the waters. Facing the water, I laid its foundation firmly, and raised it mountain high with *bitumen and burnt brick*. Mighty cedars, I caused to be laid down at length for its roofing. . . . For protection, I built two massive walls of *asphalt* and brick, 490 ells beyond Nimitti-Bel. Between them I erected a structure of bricks on which I built my kingly dwelling of *asphalt and bricks*. This I surrounded with a massive wall of *asphalt and burnt bricks*, and made upon it a lofty foundation for my royal dwelling of *asphalt and burnt bricks*."

It thus appears that Nebuchadnezzar profited by the experience of his father, and instead of building a retaining wall of dried clay bricks which had failed to hold back the Euphrates, due to its lack of waterproof properties, he resorted to the use of burnt bricks and *asphalt*, as originally practiced by Sargeon, and apparently with satisfactory results.

Koldewey's investigations (p. 31) indicate that the method of constructing walls in Babylonian times consisted in laying in rotation, first a course of bricks, then a layer of asphalt, then a layer of clay and then another course of bricks. The joints in each course were composed of asphalt and clay. In every fifth course, the clay was replaced by a matting of reeds. This matting is now entirely rotted and gone, but its impression is clearly recognizable in the asphalt. An attempt to separate the courses to prevent adhesion is thus apparent, but the reason is not obvious. Only in one locality (Temple of Borsippa) does it appear that asphalt has been used in direct contact with the bricks, where they still hold together in a firm mass.

It is probable that the asphalt used by the Babylonians was derived from springs similar to the ones still found in Mesopotamia, of which Fig. 9 is a typical example.

Fig. 10 shows the present appearance of the brick floor of Nebuchadnezzar's Throne Hall, Babylon, looking towards the Euphrates. The burnt bricks bearing the name of Nebuchadnezzar (of which one is shown in the foreground) were laid in asphalt, and are still so firmly jointed together to-day, that it is impossible to part them without destroying their integrity.¹

About 450 B.C.—Herodotus of Persia. The Persian Herodotus in his "Historiarum,"² published about 450 B.C., refers to several sources of Persian asphalt. In describing the springs of the Island of Zante, he writes: "I have myself seen the pitch drawn up out of a lake, and from water in Zacynthus; and there are several lakes there; the largest of them was 70 ft. every way and 2 orgyoe in depth; into this they let down a

¹ *National Geographic Magazine*, Feb., 1916, 29, pp. 130 and 151.

² Volume I, pp. 119 and 179; also Volume IV, p. 195.

pole with a myrtle branch fastened to the end, and then drew up the pitch adhering to the myrtle; it has the smell of *asphalt*; but is in other respects better than the pitch of Pieria." Herodotus also mentions the fact that lumps of asphalt are carried down by the waters of the Is, which discharges into the Euphrates at the City of Is, about eight days' journey from Babylon. It is probable that the City of Is referred to by Herodotus corre-



From "Light on the Old Testament," by Prof. A. T. Clay.

FIG. 9.—Asphalt Spring in Mesopotamia.

sponds to the present city of Hit, where bitumen is still found in considerable quantities. (See p. 126.)

Herodotus also states: "At Ardericca near Susa is a well which produces three different substances, since asphalt, salt and oil are drawn up from it. . . . It assumes these different forms: the asphalt and the salt immediately become solid, but the oil they collect and the Persians call it Rhadinance; it is black and emits a strong odor." At Elam in the province of Susiana in Persia, asphalt is still collected in this crude manner. Herodotus was the first to describe petroleum, of which he states an occurrence existed at Kirab, Persia.

About 430 B.C.—Xenophon of Greece. The Greek Xenophon (about 430 B.C.) in his work "Anabasis"¹ describes a wall built in Media composed of burnt bricks laid together in hot asphalt as the cementing medium. This apparently is similar to the method of construction used at Babylon.

¹ Book II, Chapter IV, Section 12.

About 400 B.C.—Hippocrates of Greece. The Greek philosopher and physician Hippocrates, in his treatise "On Airs, Waters and Places," refers to several of the asphalt deposits already mentioned.

About 350 B.C.—Aristotle of Greece. Aristotle refers to "Asphalt" in his works¹ and describes the well-known Albanian deposits still found on the eastern shore of the Adriatic Sea (see p. 90).



Copyright by Underwood & Underwood, N. Y.

FIG. 10.—Floor of Nebuchadnezzar's Temple as it Appears To-day, Showing Blocks Joined by Means of Asphalt.

About 250 B.C.—Hannibal of Carthage. Hannibal, who lived in Carthage about 250 B.C., is given the credit of having used asphalt, and possibly also mineral oils in compounding the so-called "Greek Fire" ("Ignæ Vestæ"). This was used in warfare, and was claimed to burn so fiercely that even water would not extinguish it.

¹ "De Mirabilibus Auscultationibus," Chapter CXXVII. Edition of F. Didot, 1857.

About 80 B.C.—Diodorus Siculus of Sicily. The historian Diodorus Siculus of Sicily,¹ upon referring to a peculiar manifestation which occurred in the Dead Sea, informs us that large masses of asphalt became detached from the bottom, and on account of the unusual amount of salt in the water, floated to the surface, forming small islands. Diodorus states further that before the appearance of the asphalt, a very strong odor was noticeable which darkened copper, silver and other metals. This was undoubtedly the result of volcanic action or earthquake shock. He also refers to the fact that in constructing the walls of the City of Media, the stones were cemented together with asphalt, as previously noted by Xenophon. Diodorus states that the natives gather asphalt from the Dead Sea and carry it to Egypt where they sell it to those who make a profession of embalming bodies, because "without the mixture of this material with other aromatics, it would be difficult for them to preserve these for a long time from the corruption to which they are liable."

About 30 B.C.—Strabo of Greece. Strabo, who also lived about this time (30 B.C.), in his book the "Geographica"² refers to the same manifestation, in which the surface of the Dead Sea suddenly became very much disturbed and large masses of asphalt floated to the surface. Strabo reports that the asphalt which rose to the surface first appeared in a molten condition but soon solidified. He also mentions an occurrence of asphalt in Babylon, close to the River Euphrates, probably the same as previously described by others.

About 25 B.C.—Marcus Vitruvius of Rome. The architect, Marcus Vitruvius, who lived about the time of Christ, also reported the presence of asphalt in the neighborhood of Babylon, which he describes as being of a liquid consistency.³

We have similar accounts from other writers who lived in the first century, including the Greek Plutarch,⁴ Flavius Josephus the Roman,⁵ Tacitus of Rome,⁶ and others.

About 60 A.D.—Dioscorides of Greece. In his book entitled "Materia Medica" we find an accurate description of the occurrence of asphalt in the Dead Sea, referred to by him as *Lake Asphaltites*.⁷ He also describes a compound of pitch and asphalt termed "pissasphaltum"⁸ He adds that:

¹ "Bibliotheca," Book XVI, Chapter 40; Book I, t. II, Chapter XXIX. Also "Hist. Universe," Book VI, t. XIX, Chapter XXV.

² Volume XVI, Chapters I, II, and XII; Volume I, Chapter XVI; French translation by Casat, XIV, p. 665.

³ "De Architectura," Volume VII, Chapter III.

⁴ "Life of Sylla."

⁵ "Antiquities," Book I, Chapter IV.

⁶ "The Histories," Volume V, p. 6.

⁷ "Materia Medica," I, 109; V, 145; XIX, 98; Kühn Lipsiae, 1829; Saracen, 1598.

⁸ "Materia Medica," I, 100.

"the name *Mâmîa* is given to the drug called 'Bitumen of Judea,' and to the *Mâmîa* of the tombs found in great quantities in Egypt, and which is nothing more than a mixture which the Byzantine Greeks used formerly for embalming their dead, in order that the bodies might remain in the state in which they were buried, and experience neither decay nor change. Bitumen of Judea is the substance which is obtained from the Asphaltite Lake. . . ."

About 100 A.D.—Pliny the Elder of Rome. Pliny the Elder of Rome, in his treatise "Naturalis Historia" written about the year 100 A.D.,¹ makes the interesting observation that "Real asphalt must be glossy and black, otherwise it is adulterated with pitch." He thus appears to have understood the difference between asphalt which occurred naturally, and adulterated mixtures containing pine pitch. He notes² that the Romans were in the habit of coating their images with asphalt to protect them from the weather. This corresponds to the present day use of asphalt paints for similar purposes. Pliny describes the use of asphalt for medicinal purposes and recommends it for curing boils, inflammation of the eyes, coughs, asthma, blindness, epilepsy, etc. It was sold extensively under the name "Mummy," and we are informed that the asphalt so used was actually scraped from the mummies taken from tombs. Its alleged curative properties were explained by the fact that it preserved the dead for so many centuries.

About 1300 A.D.—Marco Polo of Venice. Marco Polo at the end of the thirteenth century described seepages of liquid asphalt at Baku on the Caspian Sea.³ He also mentioned the existence of an ancient fire temple erected about flaming streams of gas and oil, which we are informed constituted a place of Hindoo pilgrimage.

1535. Discovery of Asphalt in Cuba. In the "General History of the Antilles" by G. F. Oviedo y Valdés of Spain, published in 1535, we find a description of a spring of semi-liquid asphalt in the Province Puerto Principe, near the coast, which was used for painting the hulls of ships. Another occurrence is mentioned on the shore of Havana harbor, used for similar purposes (p. 107).

1595. Discovery of "Pitch Lake" at Trinidad by Sir Walter Raleigh. In his book, the "Discoveries of Guiana," Sir Walter Raleigh gives a record of his voyage of exploration to the east coast of South America in 1595, wherein he describes his visit to the Island of Trinidad, and gives the first account of the so-called "Pitch Lake," (see p. 108).

1601. First Classification of Bituminous Substances. Andreas Libavius refers to the uses of asphalt, and classified it with mineral oil, amber and pitch. He endeavored to trace the connection between asphalt and

¹ Volume II.

² Book XXXV.

³ Book I, Chapter III.

petroleum, and gives a record of the earliest literature on asphalt including the works of Pliny, Dioscorides, Hippocrates and others.¹

1656. Early Dictionary Definition of "Bitumen." In one of the earliest dictionaries of the English language, "Blount's Glossary," bitumen is defined as:

"A kind of clay or slime naturally clammy, like pitch, growing in certain countries of Asia."

It is interesting to note the connection between this interpretation of the word, and the reference to "slime" and "slimepit" in "Genesis" (loc. cit.).

1661. Commercial Production of Wood Tar. The earliest reference to the production of wood tar on a large scale by the dry distillation of wood, occurs in Boyle's "Chemistra Scepticus," 1661. This industry is said to have been first practiced in Norway and Sweden.

1672. First Accurate Description of Persian Asphalt Deposits. Dr. J. Fryer accurately describes the occurrences of asphalt in the East Indies and Persia, in his book "Nine Years' Travels" (1672-1681).²

1673. Discovery of Elaterite. The first description of Elaterite, originally found at Castleton in Derbyshire, England (p. 150), under the name "Elastic Bitumen," is given by Lister in the *Philosophical Magazine and Journal of Science*, London, 1673.

1681. Discovery of Coal Tar and Coal-tar Pitch. In a patent taken out in England on August 19, 1681, by Becher and Serle, entitled "A new way of Makeing Pitch, and Tarre out of Pit Coale, never before found out or used by any other," we find the first description of coal tar and coal-tar pitch, as well as their methods of production.

1691. Discovery of Illuminating Gas from Coal. Dr. John Clayton, dean of Kildare, England, experimented with the inflammable gas obtained on heating coal in a closed retort. He filled bladders with this gas and demonstrated that it burnt with a luminous flame.

1694. Discovery of Shale Tar and Shale-tar Pitch. English Patent No. 330, of 1694, entitled "Pitch, Tar and Oyle, out of a kind of stone from Shropshire," granted to Hancock and Portlock, contains the earliest record of the manufacture of shale tar and shale-tar pitch.

1712-1730. Discovery of Val de Travers, Limmer and Seyssel Asphalt Deposits. The asphalt deposit in the Val de Travers in the Jura Moun-

¹"Singularium Andreæ Libavii, cont VIII libros bituminum et affinum historice, physice, chymice; de Petroleis, Ambra, Halosanthono, Succino, Gagate, Asphaltto, Piss-asphaltto, Mumia, Lithantrhace." Frankfurt, 1601. P. Kopff.

²P. 318 et seq.

tains, Canton of Neuchâtel, Switzerland, was discovered by the Greek Doctor Eyrinis d'Eyrinis in 1712, and described in detail.¹

Some give Eyrinis the credit of having likewise discovered the Limmer asphalt deposit near Hanover, Germany, in 1730, but this has not been definitely established. A third discovery of asphalt by Eyrinis, in 1735, at Seyssel in the Rhone Valley, Department of Ain, France, proved to be one of the most important deposits in Europe. This has been worked constantly up to the present time, and will be described later (p. 116).

1746. Invention of the Process of Refining Coal Tar. On August 7, 1746, a patent was granted in England to Henry Haskins disclosing: "A new method for extracting a spirit or oil from tar, and from the same process obtaining a very good pitch," consisting of our present process of fractional distillation in a closed retort connected with a worm condenser.

1777. First Exposition of Modern Theory of the Origin of Asphalt. In his "Eléments de Minéralogie," published in 1777 LeSage² classified bitumens in the sequence: "Naphtha, Petroleum, Mineral Pitch, Maltha and Asphalt," and regarded them all as originating from petroleum oil. This closely conforms to the modern views regarding the classification and origin of bitumens. (See p. 55.)

1788. Discovery of Lignite Tar. Krünitz in 1788 referred to the production of "a tar-like oil" upon destructively distilling "earth coal" (lignite). This was virtually the first description of the manufacture of lignite tar.

1790-1800. Discovery of "Composition" or "Prepared" Roofing. Admiral Faxe of Sweden³ is given credit for having produced the first prepared roofings between the years 1790 and 1800 in the following crude manner: the roof boards were first covered with plain paper, which, after being nailed in place, was coated with heated wood tar to make it waterproof.

A newspaper published in Leipsic in the year 1791 credits Michael Kag of Mühlendorf, Bavaria, with having produced an improved form of prepared roofing by saturating raw paper with varnish, and coating the surfaces with a mineral powder. The product was also recommended as a substitute for leather in the soles of shoes.

1792-1802. Manufacture of Coal Gas and Coal Tar on a Large Scale. Wm. Murdoch, of England, was the first to manufacture coal gas and coal tar on a large scale.

¹ "Dissertation sur l'asphalte ou ciment naturel, decouvert depuis quelques années au Val de Travers." Paris, 1721.

² Volume II, p. 96.

³ E. Lühmann, "Die Fabrikation der Dachpappe und der Anstrichmasse für Pappdächer," p. 1, Vienna, Budapest and Leipzig, 1883.

1797-1802. Exploitation of Seyssel Asphalt in France. M. Secretan obtained a concession from the French Government to work the asphalt deposits at Seyssel on the Rhone, France. The venture, however, did not prove a success. The deposit was next taken over by Count de Sassenay, of France, in 1802, and actively exploited. A laboratory was erected to investigate the uses of this asphalt, which was marketed in France under the name "Rock asphalt mastic," and used for surfacing floors, bridges and sidewalks, also to a limited extent for waterproofing work (see p. 374).

1815. Commercial Exploitation of Coal-tar Solvents. In 1815, F. C. Accum, of England, obtained "naphtha" by subjecting coal tar to fractional distillation on a commercial scale. This distillate was used in the manufacture of India rubber goods, for burning in open lamps and for certain kinds of varnish. The tar which remained behind had no particular value and was accordingly consumed as fuel.

1822. Discovery of Scheererite and Hatchettite. The mineral wax Scheererite was discovered in a bed of lignite (brown coal) at Uznach, near St. Gallen in Switzerland, by Captain Scheerer, in 1823. In the same year the mineral wax hatchettite or hatchetine (p. 78) was discovered on the borders of Loch Fyne, in Argyllshire, Scotland, and was named after the English chemist, C. Hatchett.

1830. Discovery of Paraffin Wax. The discovery of paraffin wax is credited to Carl von Reichenbach, of Stuttgart, Germany, who was the first to describe its physical and chemical properties.¹ He derived the material from lignite tar and christened it "Paraffin" (Parum Affinis), because of its unusual resistance to chemicals.

1833. Discovery of Ozokerite. The first reference to the mineral wax ozokerite (p. 74) was by Glocker² in *Schweizerische Apotheker-Zeitung*, 1833, 69, 215. He discovered it near the town of Slanik in Moldavia, close to a deposit of lignite at the foot of the Carpathians. It was named from the Greek words signifying "to smell" and "wax," in allusion to its odor.

1836. Asphalt First Used in London for Foot Pavements. In 1836 we first hear of Seyssel asphalt being introduced from France to London for constructing foot paths.³

1837. Publication of First Exhaustive Treatise on the Chemistry of Asphalt. The well-known treatise "Mémoire sur la composition des bitumes" was published by J. B. Boussingault in the year 1837. It was the most exhaustive treatise on the subject which had yet appeared.⁴

¹ *J. Chim. phys.*, 1830, 69, 436.

² "A System of Mineralogy," by E. S. Dana, p. 998, New York, 1906.

³ Danby, loc. cit., p. 54.

⁴ *Ann. chim. phys.*, 1837, 64, 141. Translated in "Asphalt Paving," pp. 107, by the Commissioners of Accounts of the City of New York, Feb. 3, 1904.

1838. Discovery of Process for Preserving Wood with Coal-tar Creosote.

In 1838 Bethell disclosed the use of coal-tar oil for impregnating wood.¹

1838. Asphalt First Used in the United States for Foot Pavements.

The earliest case on record of rock asphalt being used in the United States for sidewalks is in the portico of the old Merchants' Exchange Building, Philadelphia, in 1838. Seyssel asphalt was used for this purpose.

1842. Discovery of Bituminous Matter in the United States.

In 1842 appeared the first report of an asphalt deposit in the United States. It was entitled "Indurated Bitumen in Cavities of the Trap of the Connecticut Valley."²

1843. Bituminous Matters Discovered in New York State.

L. C. Beck, in 1843, wrote a paper on the occurrence of bituminous matter in several of the New York limestones and sandstones.³

1850. Discovery of "Asphaltic Coal" in New Brunswick, Nova Scotia.

C. T. Jackson published the first account of Nova Scotia "albertite" in the years 1850-1851. It was described as "Albert Coal."⁴

1854. First Compressed Asphalt Roadway Laid in Paris.

In 1854 a short stretch of compressed rock asphalt roadway was laid in Paris by M. Vaudry.⁵ This, we are told, was the outcome of observations previously made by a Swiss engineer, M. Merian who in 1849, noted that fragments of rock asphalt that fell from the carts transporting the material from the mine at Val de Travers, to the nearby village, became compressed in summer under the wheels into a crude pavement of asphalt. Merian thereupon constructed a small experimental stretch of roadway compacted with a roller.

1858. First Modern Asphalt Pavement Laid in Paris.

In 1858, the first large area of asphalt roadway was constructed on the Palais Royal in Paris. It was composed of a foundation of concrete 6 in. thick surfaced with rock asphalt mastic obtained from the Val de Travers deposit, compressed to a layer about 2 in. thick. This constituted the earliest use of sheet asphalt pavement in its modern form.

1863. Discovery of Grahamite in West Virginia.

The first account of the West Virginia grahamite deposit is given by J. P. Lesley.⁶ The material was described as a rock asphalt, but was later named "grahamite" by Henry Wurtz, in honor of the Messrs. Graham, who were largely interested in the mine.

¹ "Die Chemie und Technologie der Natürlichen und Künstlichen Asphalte," by Köhler-Graefe, pp. 21. Braunschweig, 1913.

² J. G. Percival, "Report on the Geology of Connecticut," *Am. J. Sci.*, 1842, **13**, 130.

³ *Am. J. Sci.*, 1843, **14**, 335.

⁴ *Proc. Boston Soc. Nat. Hist.*, 1850, pp. 279, also *Am. J. Sci.*, 1850, **2**, XI, 292; XIII, 276.

⁵ See "Asphalts," by T. H. Boorman, pp. 11, N. Y., 1908.

⁶ *Proc. Am. Phil. Soc.*, **9**, 183. Philadelphia, March 20, 1863.

1869. The First Compressed Asphalt Pavement in London. The first stretch of asphalt roadway in London was laid at Threadneedle Street near Finch Lane in May, 1869. It was composed of Val de Travers rock asphalt.¹

1870-6. First Asphalt Roadways in the United States. Some give the Belgium chemist, E. J. De Smedt, credit for having laid the first rock asphalt roadway in the United States, contending that in 1870 a small experimental stretch was laid with continental asphalt opposite the City Hall in Newark, N. J. According to Boorman,² the first pavement of any consequence in the United States was laid in 1872, at Union Square, New York City, composed of Val de Travers rock asphalt. In 1876, four city blocks of Neuchatel asphalt pavement were laid on Pennsylvania Avenue, Washington, D. C.

1879. First Trinidad Asphalt Pavement Laid in the United States. According to Richardson³ the first sheet asphalt pavement of Trinidad asphalt to be laid in the United States was on Vermont Avenue, Washington, D.C., in the year 1879.

1881. Use of Chemicals for Oxidizing Coal Tars and Petroleum Asphalts. The first *complete* disclosure of the process for "oxidizing" bituminous materials was by De Smedt (see p. 287). This process consisted in evaporating coal tar or asphalt in contact with substances capable of inducing oxidation (such as potassium permanganate), "to give them greater tenacity and render them, or the pavement, or other compositions in which they enter, less brittle and less liable to be affected by air or water." (See p. 289.)

1885. Discovery of Uintaite (Gilsonite) in Utah. Gilsonite, first known as "uintaite," was discovered in the Uinta Valley near Fort Duchesne, Utah, in 1885. It was first described by W. P. Blake,⁴ and was later called "gilsonite," after Mr. F. H. Gilson, of Salt Lake City.

1889. Discovery of Wurtzilite in Utah. W. P. Blake subsequently discovered a deposit of wurtzilite not far from the source of gilsonite in the Uinta Valley, Wasatch County, Utah, between Salt Lake and the Valley of the Green River.⁵ It was named after Dr. Henry Wurtz of New York.

1891. Exploitation of the Bermudez Asphalt Deposit, Venezuela. According to Köhler-Graefe,⁶ the Bermudez asphalt deposit in Venezuela was first developed in the year 1891 by the Barber Asphalt Paving Co. A

¹ Danby, loc. cit., pp. 60.

² Loc. cit., p. 11.

³ "Trinidad and Bermudez Lake Asphalts," pp. 28. Barber Asphalt Paving Co. Philadelphia.

⁴ *Eng. Mining J.*, **40**, 431. 1885.

⁵ *Eng. Mining J.*, **48**, 542. 1889.

⁶ Loc. cit., pp. 34-35.

search of the literature fails to reveal when this deposit was first discovered. The first pavement laid with this material was on Woodward Avenue, Detroit, Mich., in 1892.

1894. Use of Air for Oxidizing Petroleum Asphalt. A further development of the De Smedt process for oxidizing petroleum asphalt was brought about by F. X. Byerley, of Cleveland, O., who blew air through asphaltic oils maintained at a temperature of 600° F. The resulting product, marketed under the name of "byerlyte," attained great popularity. (See p. 287.)

CHAPTER II

TERMINOLOGY AND CLASSIFICATION OF BITUMINOUS SUBSTANCES

ONE of the most baffling problems with which we have had to deal in recent years is fixing the definitions of the various bituminous substances, and the products in which they are used in the arts.¹

The words "bitumen," "asphalt," "resin," "tar," "pitch," "wax," have been in use for many centuries, most of them long before the advent of the English language. At first, very little was known regarding the properties of these substances, and, as a result, the early writers used these terms loosely, and, in many cases, interchangeably. It is probable that each of these words at first related to the aggregate characteristics of some typical substance closely associated with the processes of daily life. As nothing of the chemistry was known when these terms originated, they were at first differentiated solely by their *physical* characteristics.

The words originally had but a limited meaning, but as new substances were discovered, they were extended in scope until the various expressions completely outgrew their former bounds. This resulted in a certain amount of overlapping and ambiguity.

As the chemistry of these substances gradually became known, this means was likewise adopted to differentiate between them, but we are still compelled to rely principally upon the physical characteristics, in arriving at a rational basis of terminology, as their chemistry has been unravelled to but a limited extent.

In defining a substance, we must rely on one or more of the following criteria:

Origin,	Solubility,
Physical Properties,	Chemical Composition.

¹ Unfortunately, at the present time there is no uniform or standard system of nomenclature, and no two authorities agree on this subject: see "Natural Asphaltum and its Compounds," J. W. Howard, Troy, N. Y., 1894; "Asphalt, Its Occurrence, Composition, Adulterations, and Commercial Uses, with Schemes for its Analysis," T. B. Stillman, *Stevens Institute Indicator*, **21**, 389, 1904; **22**, 45, 1905; *Am. Soc. Testing Materials, Standards for*, 1916; pp. 594, *Proc. Am. Soc. Testing Materials*, **16**, Part I, 594, 1916; U. S. Department of Agriculture, Office of Public Roads, *Circular No. 93*, 1911; The Engineering Standards Committee's Report on "British Standard Nomenclature of Tars, Pitches, Bitumens, and Asphalts, when used for Road Purposes," London, April, 1916; "The Modern Asphalt Pavement," by Clifford Richardson, pp. 111, New York, 1908; "The Classification of Bituminous and Resinous Substances," by Herbert Abraham, *J. Ind. Eng. Chem.*, **5**, 11, 1913.

The last three can be more or less readily ascertained from an examination of the substance itself. The origin, however, is not always apparent, but may in certain cases be deduced by inference, upon investigating the physical properties, solubility and composition of the substance under consideration. To base a definition solely upon a statement of the origin of a substance would necessitate some prior knowledge concerning its source or mode of production. As such knowledge is not always available, a definition of this kind would be very limited in its scope. Unfortunately, this plan has often been followed by many of the leading technical societies in this country and abroad, in fixing the definitions of bituminous substances.

A far better method consists in basing the definition upon the *inherent* characteristics of the substance, so as to permit of its identification without necessarily having prior knowledge concerning its origin.

The four cardinal features forming the basis of nomenclature may be further elaborated as follows:

TABLE I

Origin	Native	{ Mineral
		{ Vegetable
Origin	Pyrogenous	{ Animal
		{ Evaporation (fractional distillation)
Origin	Pyrogenous	{ Destructive distillation
		{ Heating in a closed vessel
Origin	Pyrogenous	{ Blowing with air.
		{ Light (white, yellow or brown)
Origin	Color in Mass	{ Dark (black)
		{ Liquid
Origin	Consistency or Hardness	{ Viscous
		{ Semi-solid
Origin	Consistency or Hardness	{ Solid
		Physical Properties
Physical Properties	Fracture	
		Physical Properties
Physical Properties	Lustre	
		Physical Properties
Physical Properties	Feel	
		Physical Properties
Physical Properties	Feel	
		Physical Properties
Physical Properties	Odor	
		Physical Properties
Physical Properties	Volatility	
		Physical Properties
Physical Properties	Fusibility	
		Physical Properties

TABLE I—*Continued*

Solubility	{ Non-mineral constituents in carbon disulphide Distillate at 300 to 350° C. in sulphuric acid (i.e., "sulphonation residue")
Chemical Composition	
	{ Hydrocarbons (compounds containing carbon and hydrogen) Oxygenated bodies (compounds containing carbon, hydrogen, and <i>oxygen</i>) Crystallizable paraffines (crystallize at low temperatures) Mineral matter (inorganic substances).

In Table II on p. 22 the principal types of bituminous substances are classified according to the features enumerated in Table I.

The definitions which follow are based upon this classification. Although reference is made to the origin of the substance, nevertheless, this is but incidental, and with the exception of the generic terms, the definitions would be explicit even though this feature were omitted.

Bituminous Substances.¹ A class of native and pyrogenous² substances containing bitumens or pyrobitumens, or resembling them in their physical properties.

NOTE. This definition includes bitumens, pyrobitumens, pyrogenous distillates (pyrogenous waxes and tars) and pyrogenous residues (pitches and pyrogenous asphalts).

Bitumen.³ A generic term applied to native substances of variable color, hardness and volatility; composed of hydrocarbons substantially free from oxygenated bodies; sometimes associated with mineral matter, the non-mineral constituents being *fusible* and largely *soluble* in carbon disulphide; and whose distillate fractioned between 300 and 350° C. yields *considerable sulphonation residue*.

NOTE. This definition includes petroleums, native asphalts, native mineral waxes and asphaltites.

Pyrobitumen.⁴ A generic term, applied to native substances of dark color; comparatively hard and non-volatile; composed of hydrocarbons, which may or may not contain oxygenated bodies; sometimes associated with mineral matter, the non-mineral constituents being *infusible* and relatively *insoluble* in carbon disulphide.

¹ The scope of the word "bituminous" is based on the commonly accepted interpretation of the suffix "ous," signifying: (1) to contain; (2) to resemble, to partake of the nature, to have the qualities (e.g., *silicious*: containing silica or resembling silica; *resinous*: containing or resembling resin; *oleaginous*: containing or resembling oil; *calcareous*: containing or resembling lime). Similarly, the word "bituminous" is construed to include substances, either *containing* more or less bitumen (or pyrobitumen), or else *resembling* them in their appearance or qualities.

² The expression "pyrogenous" implies that the substance was produced by means of heat or fire.

³ The interpretation of the term "bitumen" as employed in this treatise is entirely disassociated from the idea of *solubility* (in certain solvents for hydrocarbons), and has no connection whatsoever with the inappropriate expression "total bitumen," used in many contemporary text-books to designate the amount soluble in carbon disulphide, and which perhaps is largely responsible for the existing confusion in the terminology.

⁴ The expression "pyrobitumen" implies that the substance when subjected to heat or fire will generate, or become transformed into bodies resembling bitumens (in their solubility and physical properties).

TABLE II

BITUMINOUS SUBSTANCES.	PHYSICAL PROPERTIES.							SOLUBILITY.		
	ORIGIN.	Color in Mass.	Consistency.	Lustre.	Feel.	Odor.	Volatility.	Fusibility, Non-mineral constituents.	Non-mineral constituents in Carbon Disulfide.	Sublimation Residue of 300 to 350° C. Disillate.
Bitumen.	Native.	Variable (light to dark).	Variable (liquid to solid).	Variable.	Harder varieties are fusible.	Largely soluble.	Considerable.
Pyrobitumen.	Native.	Dark.	Comparatively hard.	Resinous to dull.	Non-adherent.	Non-volatile.	Infusible.	Relatively insoluble.
Petroleum.	Native.	Variable (light to dark).	Liquid.	Oily.	Characteristic ("oily").	Comparatively volatile.	Soluble.	Considerable.
Mineral Wax.	Native or pyrogenous.	Variable (light to dark).	Viscous to solid.	Characteristic ("waxy").	Unctuous.	Comparatively non-volatile.	Fusible.	Soluble.	Considerable.
Asphalt.	Native or pyrogenous.	Dark.	Variable.	Harder varieties resinous to dull.	Adherent to non-adherent.	Comparatively non-volatile.	Fusible.	Largely soluble.	Considerable.
Asphaltite.	Native.	Dark.	Comparatively hard.	Resinous	Non-adherent.	Non-volatile.	Difficultly fusible.	Largely soluble.	Considerable.
Asphaltic pyrobitumen.	Native.	Dark.	Comparatively hard.	Resinous to dull.	Non-adherent.	Non-volatile.	Infusible.	Largely insoluble.
Non-asphaltic pyrobitumen.	Native.	Dark.	Comparatively hard.	Resinous to dull.	Non-adherent.	Non-volatile.	Infusible.	Largely insoluble.
Tar.	Pyrogenous.	Dark.	Liquid.	Oily.	Characteristic ("tarry").	Comparatively volatile.	Largely soluble.	Comparatively little.
Pitch.	Pyrogenous.	Dark.	Viscous to solid.	Resinous to dull.	Adherent to non-adherent.	Comparatively non-volatile.	Fusible.	Largely soluble.	Comparatively little.

COMPOSITION.

Hydrocarbons, substantially free from oxygenated bodies, sometimes associated with mineral matter.

Hydrocarbons, which may or may not contain oxygenated bodies, sometimes associated with mineral matter.

Hydrocarbons, substantially free from oxygenated bodies.

Hydrocarbons, substantially free from oxygenated bodies, containing crystallizable paraffines, sometimes associated with mineral matter.

Hydrocarbons, substantially free from oxygenated bodies, containing little to no crystallizable paraffines, sometimes associated with mineral matter.

Hydrocarbons, substantially free from oxygenated bodies containing crystallizable paraffines, sometimes associated with mineral matter.

Hydrocarbons, containing oxygenated bodies, sometimes associated with mineral matter.

Variable.

Variable.

NOTE. This definition includes the asphaltic and non-asphaltic pyrobitumens, and their respective shales.

Petroleum. A species of bitumen, of variable color, *liquid* consistency, having a characteristic odor; comparatively volatile; composed of hydrocarbons, substantially free from oxygenated bodies; soluble in carbon disulphide; and whose distillate fractioned between 300 and 350° C., yields *considerable sulphonation residue*.

NOTE. This definition includes non-asphaltic, mixed-base and asphaltic petroleum.

Mineral Wax. A term applied to a species of bitumen, also to certain pyrogenous substances; of variable color, viscous to solid consistency; having a *characteristic lustre* and *unctuous feel*; comparatively non-volatile; composed of hydrocarbons, substantially free from oxygenated bodies; containing *considerable crystallizable* paraffines; sometimes associated with mineral matter, the non-mineral constituents being easily fusible and soluble in carbon disulphide.

NOTE. This definition is applied to native mineral waxes and pyrogenous waxes. Native mineral waxes include ozokerite, montan wax, etc. Pyrogenous waxes include the solid paraffines separated from non-asphaltic and mixed-base petroleum, peat tar, lignite tar and shale tar.

Asphalt. A term applied to a species of bitumen, also to certain pyrogenous substances of *dark color*, variable hardness, comparatively non-volatile; composed of hydrocarbons, substantially free from oxygenated bodies; containing relatively little to no crystallizable paraffines; sometimes associated with mineral matter, the non-mineral constituents being *fusible*, and largely soluble in carbon disulphide; and whose distillate fractioned between 300 and 350° C., yields *considerable sulphonation residue*.

NOTE. This definition is applied to native asphalts and pyrogenous asphalts. Native asphalts include asphalts occurring naturally in a pure or fairly pure state, also asphalts associated naturally with a substantial proportion of mineral matter. Pyrogenous asphalts include residues obtained from the distillation, blowing, etc., of petroleum (e.g., residual oil, blown asphalts, residual asphalts, sludge asphalt, etc.), also from the pyrogenous treatment of wurtzilite (e.g., wurtzilite asphalt).

Asphaltite. A species of bitumen, including dark colored, comparatively hard and non-volatile solids; composed of hydrocarbons, substantially free from oxygenated bodies and crystallizable paraffines; sometimes associated with mineral matter, the non-mineral constituents being *difficultly fusible*, and largely soluble in carbon disulphide; and whose distillate fractioned between 300 and 350° C. yields *considerable sulphonation residue*.

NOTE. This definition includes gilsonite, glance pitch, and grahamite.

Asphaltic Pyrobitumen. A species of pyrobitumen, including dark colored, comparatively hard and non-volatile solids; composed of hydrocarbons, *substantially free from oxygenated bodies*; sometimes associated with mineral matter, the non-mineral constituents being *infusible* and largely *insoluble* in carbon disulphide.

NOTE. This definition includes elaterite, wurtzilite, albertite, impsomite and the asphaltic pyrobituminous shales.

Non-asphaltic Pyrobitumen. A species of pyrobitumen, including dark-colored, comparatively hard and non-volatile solids; composed of hydrocarbons, *containing oxygenated bodies*; sometimes associated with mineral matter, the non-mineral constituents being *infusible*, and largely *insoluble* in carbon disulphide.

NOTE. This definition includes peat, lignite, cannel coal, bituminous coal, anthracite coal, and the non-asphaltic pyrobituminous shales.

Tar. A term applied to pyrogenous distillates of dark color, *liquid* consistency; having a characteristic odor; comparatively volatile; of variable composition, sometimes associated with carbonaceous matter, the non-carbonaceous constituents being largely soluble in carbon disulphide; and whose distillate fractioned between 300 and 350° C., yields comparatively *little sulphonation residue*.

NOTE. This definition includes the volatile oily decomposition products obtained from the pyrogenous treatment of petroleum (water-gas tar and oil-gas tar), bones (bone tar), wood and roots of coniferæ (pine tar), hardwoods, such as oak, maple, birch, and beech (hardwood tar), peat (peat tar), lignite (lignite tar), bituminous coal (gas-works coal-tar, coke-oven coal-tar, blast-furnace coal-tar, producer-gas coal-tar, etc.), and pyrobituminous shales (shale tar).

Pitch. A term applied to pyrogenous residues, *of dark color*, viscous to solid consistency; comparatively non-volatile, fusible; of variable composition; sometimes associated with carbonaceous matter, the non-carbonaceous constituents being largely soluble in carbon disulphide; and whose distillate fractioned between 300 and 350° C. yields comparatively *little sulphonation residue*.

NOTE. This definition includes residues obtained from the distillation of tars (oil-gas-tar pitch, water-gas-tar pitch, bone-tar pitch, wood-tar pitch, peat-tar pitch, lignite-tar pitch, gas-works coal-tar pitch, coke-oven coal-tar pitch, blast-furnace coal-tar pitch, producer-gas coal-tar pitch, and shale-tar pitch); also from the distillation of fusible organic substances, the process having been terminated before the formation of coke (rosin pitch and fatty-acid pitch).

It will be noted that the terms "mineral wax" and "asphalt" are each applied indiscriminately to native and pyrogenous substances. This is due to the fact that

at the present time it is practically impossible to distinguish between certain native and pyrogenous asphalts or mineral waxes, either by physical or chemical means. It is probable that some method may be discovered for accomplishing this, in which event it would be of decided advantage to frame separate definitions to distinguish between native and pyrogenous substances respectively. With the knowledge available at present, however, this cannot readily be accomplished. We must be content, therefore, to apply the term "asphalt" and "mineral wax" both to native substances and to manufactured (pyrogenous) products.

In many of the early classifications, natural gas and marsh gas were included within the scope of the term "bitumen." As this stretches the meaning to an abnormal extent, the author deems it inadvisable to include natural gases in the definitions and classification given in this book.

The term "maltha," frequently found in contemporary classifications to designate the softer varieties of native asphalt, has been omitted for the sake of brevity.

The preceding definitions enable us to arrive at the following classification of bituminous substances, in which are included the most important members recognized commercially.

TABLE III.—BITUMINOUS SUBSTANCES

GENUS.	SPECIES.	MEMBER.	REMARKS.
Bitumens	Petroleums	Non-asphaltic Mixed-base Asphaltic	Contains an appreciable quantity of crystallizable paraffine and no asphalt. Contains crystallizable paraffine, also asphalt. Contains an appreciable quantity of asphalt and no crystallizable paraffine.
	Native mineral waxes	Ozokerite Montan wax	A paraffineous mineral, called ceresine when refined. The wax extracted from lignite or pyropissite by means of solvents.
	Native asphalts	Pure or fairly pure Associated with mineral matter	Comparatively free from associated mineral matter (less than 10 per cent on the dry weight.) Containing a substantial proportion of sand, sandstone, limestone, clay or shale.
	Asphaltites	Gilsonite Glance pitch Grahamite	Extremely pure Pure to moderately pure Pure to quite impure
	Asphaltic pyrobitumens	Elaterite Wurtzilite Albertite Impsonite Asphaltic pyrobituminous shales	Rubbery—partly saponifiable Depolymerizes on heating, becoming fusible and soluble Depolymerizes partially on heating Does not depolymerize on heating. Mineral matters predominate. Infusible and insoluble.
Pyrobitumens	Non-asphaltic pyrobitumens	Peat Lignite Bituminous coal Anthracite coal Lignitic and coal shales	Generally pure. Infusible and insoluble. Derived from petroleum. Pure or fairly pure. Infusible and insoluble. Contain more or less oxygenated bodies. Derived from vegetable growths. Gradual transition from peat to lignite to coal. Mineral matters predominate, otherwise the same as the foregoing.

	<p>Wax tailings.....</p> <p>Petroleum paraffine.....</p> <p>Peat paraffine.....</p> <p>Lignite paraffine.....</p> <p>Shale paraffine.....</p>	<p>Distillate from petroleum obtained immediately prior to coking.</p> <p>Solid paraffine obtained from non-asphaltic petroleum.</p> <p>Solid paraffine obtained from peat tar.</p> <p>Solid paraffine obtained from lignite tar.</p> <p>Solid paraffine obtained from shale tar.</p>
<p>Pyrogenous distillates</p>	<p>Oil-gas tar.....</p> <p>Water-gas tar.....</p> <p>Pine tar.....</p> <p>Hardwood tar.....</p> <p>Peat tar.....</p> <p>Lignite (brown coal) tar.....</p> <p>Shale tar.....</p> <p>Gas-works coal-tar.....</p> <p>Coke-oven coal-tar.....</p> <p>Blast-furnace coal-tar.....</p> <p>Producer-gas coal-tar.....</p> <p>Bone tar.....</p>	<p>Produced by cracking petroleum vapors in manufacturing oil gas.</p> <p>Produced by cracking petroleum vapors in manufacturing carburetted water gas.</p> <p>Produced by the destructive distillation of the wood and roots of conifers.</p> <p>Produced by the destructive distillation of hardwoods.</p> <p>Produced by the destructive distillation of peat.</p> <p>Produced by the destructive distillation of lignite (brown coal).</p> <p>Produced by the destructive distillation of pyrobituminous shales.</p> <p>Produced from gas-house retorts in manufacturing gas from bituminous coal.</p> <p>Produced from by-product coke-oven in manufacturing coke from bituminous coal.</p> <p>Produced from blast-furnaces upon smelting metals with bituminous coal.</p> <p>Produced from gas-producers in manufacturing producer gas from coal.</p> <p>Produced by the destructive distillation of bones.</p>
<p>Pyrogenous tars</p>	<p>Residual oils.....</p> <p>Blown petroleum asphalts.....</p> <p>Residual asphalts.....</p> <p>Sludge asphalts.....</p> <p>Wurtzillite asphalt.....</p>	<p>Produced by the dry distillation of non-asphaltic petroleum, the dry or steam distillation of mixed-base petroleum or the steam distillation of asphaltic petroleum.</p> <p>Produced by blowing air through heated residual oils.</p> <p>Produced by the steam distillation of mixed-base and asphaltic petroleum.</p> <p>Produced from the acid sludge obtained in the purification of petroleum distillates with sulphuric acid.</p> <p>Produced by depolymerizing wurtzillite in closed retorts.</p>
<p>Pyrogenous asphalts</p>	<p>Oil-gas-tar pitch.....</p> <p>Water-gas-tar pitch.....</p> <p>Wood-tar pitch.....</p> <p>Peat-tar pitch.....</p> <p>Lignite-tar pitch.....</p> <p>Shale-tar pitch.....</p> <p>Gas-works coal-tar pitch.....</p> <p>Coke-oven coal-tar pitch.....</p> <p>Blast-furnace coal-tar pitch.....</p> <p>Producer-gas coal-tar pitch.....</p> <p>Bone-tar pitch.....</p> <p>Rosin pitch.....</p> <p>Fatty-acid pitch.....</p>	<p>Residues obtained by the partial evaporation or distillation of the respective tars.</p> <p>Residue obtained by the partial distillation of the resinous sap of conifers.</p> <p>Residue obtained by the steam distillation of fatty-acids.</p>
<p>Pyrogenous residues</p>	<p>Pyrogenous pitches</p>	<p>Residues obtained by the partial evaporation or distillation of the respective tars.</p>

CHAPTER III

CHEMISTRY OF BITUMINOUS SUBSTANCES

STRUCTURAL FORMULAS OF THE MOST IMPORTANT PURE CHEMICAL SUBSTANCES PRESENT IN BITUMINOUS COMPLEXES

BITUMINOUS substances are complex mixtures of chemical compounds containing the elements carbon and hydrogen in varying proportions and combined in different ways. These compounds may also contain the elements oxygen, sulphur, and nitrogen. Certain bituminous substances and especially those found in nature, contain more or less extraneous mineral matter. Carbon and hydrogen, however, are present in the chemical compounds contained in *all* types of bituminous substances. These two elements have the properties of forming a bewildering number of combinations—in fact more than any other two elements. Substances composed of carbon and hydrogen are termed “hydrocarbons.”

Each element has the power of combining with other elements in certain definite ratios. The combining power of the element hydrogen is taken as unity, and it is therefore said to have a “valency” of 1. Oxygen is capable of combining with 2 atoms of hydrogen, forming a molecule of water (H₂O), and therefore has a valency of 2. Similarly, carbon can combine with four atoms of hydrogen, and has a valency of 4. These valencies may be pictured mentally as bonds or joinings, holding the elements together. For the sake of convenience, they are represented graphically by dashes, thus:

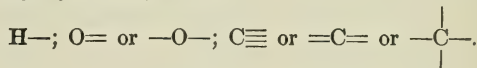

Carbon atoms, moreover, have the property of uniting with one another. When but two carbon atoms combine, the union may occur in three ways:

(1) Two carbon atoms may unite with a single valency joining them together, leaving three *free* valencies for each carbon atom, or a total of six, illustrated as follows:

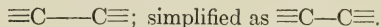

(2) The carbon atoms may be bonded together with two valencies, leaving four free valencies, thus:

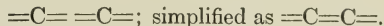

(3) The carbon atoms may be joined together by three valencies, leaving but two uncombined valencies, thus:

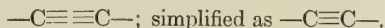

The free valencies may unite with hydrogen atoms or other carbon atoms, forming an endless number of combinations, and constituting a *series* of hydrocarbons, thus:

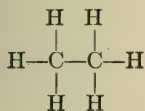

C_2H_6 Ethane
($\text{CH}_3 \cdot \text{CH}_3$)

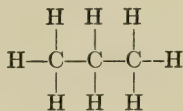

C_3H_8 Propane
($\text{CH}_3 \cdot \text{CH} \cdot \text{CH}_3$)

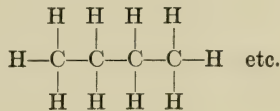

C_4H_{10} Butane
($\text{CH}_3 \cdot \text{CH} \cdot \text{CH} \cdot \text{CH}_3$)

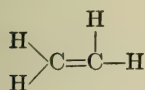

C_2H_4 Ethylene
($\text{CH}_2 : \text{CH}_2$)

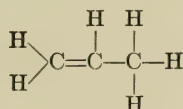

C_3H_6 Propylene
($\text{CH}_2 : \text{CH} \cdot \text{CH}_3$)

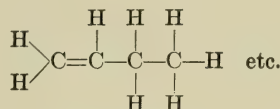

C_4H_8 Butylene
($\text{CH}_2 : \text{CH} \cdot \text{CH}_2 \cdot \text{CH}_3$)

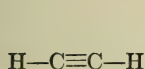

C_2H_2 Acetylene
($\text{CH} : \text{CH}$)

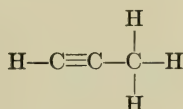

C_3H_4 Allylene
($\text{CH} : \text{C} \cdot \text{CH}_3$)

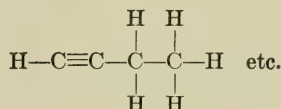

C_4H_6 Ethylacetylene
($\text{CH} : \text{C} \cdot \text{CH}_2 \cdot \text{CH}_3$)

These are termed "open chain hydrocarbons," because all the carbon atoms are connected together in a straight line. The first three examples, ethane, propane, and butane, are said to be members of a *saturated* series because no two carbons are held together by more than *one* valency, or in other words, all the carbon atoms are "saturated" or combined with hydrogen. This particular series of hydrocarbons has been named "paraffines," because the various members are ordinarily found in paraffinaceous petroleum and paraffine wax. In each member there exists a definite ratio between the number of carbon and hydrogen atoms respectively. For each atom of carbon present, we find two more than twice as many of hydrogen atoms. The paraffine series is accordingly represented by the general formula $\text{C}_n\text{H}_{2n+2}$ in which n may range from 1 in the lowest member CH_4 , to as high as 60 in $\text{C}_{60}\text{H}_{122}$.

The three substances, ethylene, propylene, and butylene, similarly belong to an open chain series of hydrocarbons known as the "olefines" having the general formula C_nH_{2n} . Since all the carbon valencies are not combined or satiated with hydrogen, this series is known as an "unsaturated" one.

The three substances, acetylene, allylene, and ethyl acetylene belong to the unsaturated "acetylene series" represented by the general formula $\text{C}_n\text{H}_{2n-2}$. The acetylene series is obviously more unsaturated than the olefines. Similarly, we have the diolefine series which has the same general formula as the acetylenes, namely $\text{C}_n\text{H}_{2n-2}$, but which is distinguished from the latter by having two double-bonded carbon groups instead of one triple-bonded group. These will be described in greater detail later.

The olefinacetylene series (also known as the valylene series) is represented by the general formula C_nH_{2n-4} , characterized by the presence of both doubly- and triply-bonded carbon groups.

The next higher series of unsaturated open chain hydrocarbons is known as the diacetylene series C_nH_{2n-6} , characterized by two triply-bonded carbon groups.

Following these we have the C_nH_{2n-8} , C_nH_{2n-10} , and the C_nH_{2n-12} series in the order mentioned. All of these are found in petroleum. It is highly probable that hydrocarbon series of still higher order exist in bituminous substances, but no means have as yet been devised to isolate them.

It should be borne in mind that two or more substances may have the same number of carbon and hydrogen atoms, and yet be constituted differently structurally. Thus, the substance butane, C_4H_{10} may exist in two possible forms, termed "isomers." These include "normal butane" shown above, and the so-called "isobutane" also known as "trimethylmethane," shown diagrammatically as follows:

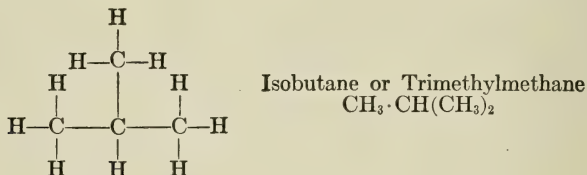

In a similar manner, the substance "butylene" may occur in three isomers, all having the same general formula C_4H_8 , as follows:

Butylene	$CH_2 : CH \cdot CH_2 \cdot CH_3$ as shown above;
Pseudobutylene	$CH_3 \cdot CH : CH \cdot CH_3$; and
Isobutylene	$CH_2 : C(CH_3)_2$.

Similarly, ethylacetylene (crotonylene), C_4H_6 , occurs in another isomeric form, dimethylacetylene, $CH_3 \cdot C : C \cdot CH_3$.

In addition to the open-chain hydrocarbons, there occur "cyclic" or "ring" hydrocarbons in which the carbon atoms are joined together in a circle, in both the saturated and unsaturated forms. The saturated cyclic hydrocarbons are known as "polymethylenes." These may in turn be divided into two classes, namely, those consisting of but one ring or cycle, and those consisting of more than one ring or cycle. The former are termed "naphthenes" or "monocyclic polymethylenes," and the latter "polycyclic polymethylenes." The polycyclic polymethylenes may be further grouped into dicyclic polymethylenes, tricyclic polymethylenes, etc. Unsaturated cyclic hydrocarbons are grouped into monocyclic and polycyclic series, known as "cyclic olefines," "terpenes," "benzenes," etc.

We will now consider the individual hydrocarbon series:

OPEN CHAIN HYDROCARBONS

C_nH_{2n+2} SERIES—SATURATED—SINGLE BONDS—"PARAFFINES"

The various members of this series are shown in Table IV on p. 31:

As already stated, butane has two isomers, similarly pentane occurs in three isomers, hexane in six, heptane in nine, octane in eighteen, and finally tridecane in 802 isomers. It follows therefore that as we ascend the scale, the number of possible isomers increases rapidly.

TABLE IV.— C_nH_{2n+2} SERIES—"PARAFFINES"—SATURATED—SINGLE BONDS

Name.	Formula.	Melting-point, Deg. C.	Boiling-point, Deg. C.
			At 760 mm.
<i>Gaseous</i>			
Methane.....	CH_4	-186	-165
Ethane.....	C_2H_6 $CH_3 \cdot CH_3$	-172	-93
Propane.....	C_3H_8 $CH_3 \cdot CH_2 \cdot CH_3$	-195	-45
Normal Butane.....	C_4H_{10} $CH_3 \cdot CH_2 \cdot CH_2 \cdot CH_3$	-135	+ 1
Trimethyl Methane.....	C_4H_{10} $CH_3 \cdot CH(CH_3)_2$		- 17
<i>Liquid</i>			
Normal Pentane.....	C_5H_{12} $CH_3 \cdot (CH_2)_3 \cdot CH_3$		+ 38
Dimethyl-ethyl Methane.....	C_5H_{12} $CH_3 \cdot CH_2 \cdot CH(CH_3)_2$		+ 30
Tetramethyl Methane.....	C_5H_{12} $C(CH_3)_4$		+ 10
Normal Hexane.....	C_6H_{14} $CH_3 \cdot (CH_2)_4 \cdot CH_3$		+ 69
Methyl-diethyl Methane.....	C_6H_{14} $CH_3 \cdot (C_2H_5)_2CH$		+ 64
Dimethyl-propyl Methane.....	C_6H_{14} $CH_3 \cdot (CH_2)_2 \cdot CH(CH_3)_2$		+ 62
Di-isopropyl.....	C_6H_{14} $(CH_3)_2 \cdot (CH_2)(CH_3)_2$		+ 58
Trimethyl-ethyl Methane.....	C_6H_{14} $CH_3 \cdot CH_2 \cdot C(CH_3)_3$		+ 45
Heptane.....	C_7H_{16}		+ 98
Octane.....	C_8H_{18}		125
Nonane.....	C_9H_{20}	- 51	150
Decane.....	$C_{10}H_{22}$	- 31	173
Undecane.....	$C_{11}H_{24}$	- 26	195
Dodecane.....	$C_{12}H_{26}$	- 12	214
Tridecane.....	$C_{13}H_{28}$	- 6	234
Tetradecane.....	$C_{14}H_{30}$	+ 5	252
Pentadecane.....	$C_{15}H_{32}$	10	270
Hexadecane.....	$C_{16}H_{34}$	18	287
Heptadecane.....	$C_{17}H_{36}$	22	303
<i>Solid</i>			
Octadecane.....	$C_{18}H_{38}$	28	317
Nonadecane.....	$C_{19}H_{40}$	32	330
			At 15 mm.
Eicosane.....	$C_{20}H_{42}$	37	205
Heneicosane.....	$C_{21}H_{44}$	40	215
Docosane.....	$C_{22}H_{46}$	44	225
Tricosane.....	$C_{23}H_{48}$	48	234
Tetracosane.....	$C_{24}H_{50}$	51	243
Pentacosane.....	$C_{25}H_{52}$	53	
Hexacosane.....	$C_{26}H_{54}$	56	
Heptacosane.....	$C_{27}H_{56}$	58	270
Octocosane.....	$C_{28}H_{58}$	60	
Nonocosane.....	$C_{29}H_{60}$	62	
Triocontane.....	$C_{30}H_{62}$	64	
Hentriocontane.....	$C_{31}H_{64}$	66	302
Dotriacontane.....	$C_{32}H_{66}$	68	310
Tritriacontane.....	$C_{33}H_{68}$	70	
Tettracontane.....	$C_{34}H_{70}$	72	
Pentatriacontane.....	$C_{35}H_{72}$	75	331
Dimyriyl.....	$C_{60}H_{122}$	102	

The specific gravity, boiling- and melting-points increase with the molecular weight. In the case of isomers, those of normal structure have the highest boiling-points. The higher members are volatile without decomposition only under reduced pressure. The same general rules hold true with other hydrocarbon series.

The gaseous members of the paraffine series are found in marsh gas, natural gas and coal gas. The liquid members are associated together in certain forms of

petroleum, such as Pennsylvania petroleum. The solid members occur in ozokerite and the various types of paraffine wax.

Paraffinaceous petroleum is composed of a mixture of the individual members of the paraffine series in varying proportions. It is a difficult matter to isolate the individual hydrocarbons in their pure state. For commercial purposes, petroleum is separated by distillation into various liquids or solids sold under the trade names of gasolene, benzine, naphtha, kerosene, lubricating oil, paraffine oil, paraffine wax, petroleum asphalt, etc. Each of these consists of complex mixtures of the individual hydrocarbons in indefinite proportions.

Paraffine wax contains solid hydrocarbons of high boiling-point (about 300° C.), and ozokerite solid hydrocarbons ranging from $C_{24}H_{50}$ upward.

C_nH_{2n} SERIES—UNSATURATED—ONE DOUBLE BOND—"OLEFINES"

The well-known members of this series are shown in the following table:

TABLE V.— C_nH_{2n} SERIES—"OLEFINES"—UNSATURATED—ONE DOUBLE BOND

Name.	Formula.	Melting-point. Deg. C.	Boiling-point. Deg. C.
<i>Gaseous:</i>			
Ethylene.....	C_2H_4 $CH_2 : CH_2$	-169	at 760 mm. -103
Propylene.....	C_3H_6 $CH_3 \cdot CH : CH_2$		-50
Butylene.....	C_4H_8		
Ethyl-ethylene.....	$C_2H_5 \cdot CH : CH_2$		-5
Sym. Dimethyl-ethylene.....	$CH_3 \cdot CH : CH \cdot CH_3$		+1
Isobutylene.....	$(CH_3)_2C : CH_2$		-6
<i>Liquid:</i>			
Amylene.....	C_5H_{10}		
Norm. propyl-ethylene.....	$CH_3 \cdot (CH_2)_2CH : CH_2$		+39
Isopropyl-ethylene.....	$(CH_3)_2 \cdot CH \cdot CH : CH_2$		+20
Sym. Methyl-ethyl-ethylene.....	$CH_3 \cdot CH : CH \cdot C_2H_5$		36
Unsym. Methyl-ethyl-ethylene.....	$(CH_3)(C_2H_5)C : CH_2$		31
Trimethyl-ethylene.....	$(CH_3)_2C : CH(CH_3)$		36
Hexylene (n).....	C_6H_{12}		69
Heptylene.....	C_7H_{14}		95
Octylene.....	C_8H_{16}		122
Nonylene.....	C_9H_{18}		153
Decylene.....	$C_{10}H_{20}$		172
Undecylene.....	$C_{11}H_{22}$		195
Dodecylene.....	$C_{12}H_{24}$	-31	213
Tridecylene.....	$C_{13}H_{26}$		233
Tetradecylene.....	$C_{14}H_{28}$	-12
Hexadecylene.....	$C_{16}H_{32}$	+4	275
Heptadecylene.....	$C_{17}H_{34}$	+12
Octadecylene.....	$C_{18}H_{36}$	+18
Eikosylene.....	$C_{20}H_{40}$		314
<i>Solid:</i>			
Cerotene.....	$C_{27}H_{54}$	+58
Melene.....	$C_{30}H_{60}$	+62	375

These are present in American petroleum in very small amounts. Certain members have been identified in Canadian petroleum, also in shale oil. The higher members of the olefine series occur in isomeric forms in the same way as the paraffines.

C_nH_{2n-2} SERIES—UNSATURATED—ONE TRIPLE BOND—"ACETYLENES"

The best known members of this series are included in the following table:

TABLE VI.— C_nH_{2n-2} SERIES—"ACETYLENES"—UNSATURATED—ONE TRIPLE BOND

Name.	Formula.	Boiling-point, Deg. C.
<i>Gaseous:</i>		
Acetylene.....	C_2H_2 CH : CH
Allylene.....	C_2H_4 CH ₂ ·C : CH
<i>Liquid:</i>		
Crotonylene.....	C_4H_6 CH ₃ ·C : C·CH ₃	27
Ethyl-acetylene.....	C_4H_6 C ₂ H ₅ ·C : CH.....	18
Methyl-ethyl-acetylene.....	C_5H_8 CH ₃ ·C : C·C ₂ H ₅	55
Normal-propyl-acetylene.....	C_5H_8 CH ₃ ·CH ₂ ·CH ₂ ·C : CH.....	48
Isopropyl-acetylene.....	C_5H_8 (CH ₃) ₂ CH·C : CH.....	28
Methyl-n-propyl-acetylene.....	C_6H_{10} CH ₃ ·C : C·(CH ₂) ₂ CH ₃	84

The lower members have not been identified in any petroleum, although several of the higher members are found in Texas, Louisiana, and Ohio oils, and are also present in coal tar.

C_nH_{2n-2} SERIES—UNSATURATED—TWO DOUBLE BONDS—"DIOLEFINES"

The more important members of this series are shown in Table VII.

TABLE VII.— C_nH_{2n-2} SERIES—"DIOLEFINES"—UNSATURATED—TWO DOUBLE BONDS

Name.	Formula.	Boiling-point, Deg. C.
Allylene (Propadiene).....	CH ₂ : C : CH ₂	Gas
Divinyl (Erythrene).....	CH ₂ : CH·CH : CH ₂	- 5
Piperylene (α-Methylbutadiene).....	CH ₂ : CH·CH : CH·CH ₃	42
Isoprene (β-Methylbutadiene).....	CH ₂ : CH·C(CH ₃) : CH ₂	35
Di-isopropenyl.....	CH ₂ : C(CH ₃)·C(CH ₃) : CH ₂	71
1-1-3-Trimethylbutadiene.....	(CH ₃) ₂ C : CH·C(CH ₃) : CH ₂	93
Diallyl.....	CH ₂ : CH·CH ₂ ·CH ₂ ·CH : CH ₃	59
2-5-Dimethyl-1-5-hexadiene.....	CH ₂ : C(CH ₃)·CH ₂ ·CH ₂ ·C(CH ₃) : CH ₂	137
1-1-5-Trimethyl-1-5-hexadiene.....	(CH ₃) ₂ C : CH·CH ₂ ·CH ₂ ·C(CH ₃) : CH ₂	141
Conylene.....	CH ₂ : CH·CH ₂ ·CH : CH·CH ₂ ·CH ₂ ·CH ₃	126

These occur in tars and certain petroleum.

C_nH_{2n-4} SERIES—UNSATURATED—ONE DOUBLE AND ONE TRIPLE BOND—"OLEFINACETYLENES"

Individual members of this series have been identified in Ohio petroleum, also also in certain types of California petroleum.

C_nH_{2n-4} SERIES—UNSATURATED—THREE DOUBLE BONDS—"POLYOLEFINES"

To this series belong the hydrocarbons known as "terpenes," none of which is present to any appreciable extent in bitumens, tars, or pitches.

C_nH_{2n-6} SERIES—UNSATURATED—TWO TRIPLE BONDS—"DIACETYLENES"

This series is also relatively unimportant, and includes diacetylene, $H \cdot C : C : C : C \cdot H$, dipropargyl, $CH : C \cdot CH_2 \cdot CH_2 \cdot C : CH$ (also known as hexadine), dimethyldiacetylene, $CH_3 \cdot C : C : C : C \cdot CH_3$, etc.

CYCLIC HYDROCARBONS

 C_nH_{2n} SERIES—SATURATED—SINGLE BONDS—MONOCYCLIC—"NAPHTHENES" ALSO CALLED "CYCLOPARAFFINES" OR "POLYMETHYLENES."

The following constitute the more important members of the naphthenes:

TABLE VIII.— C_nH_{2n} —SERIES—"NAPHTHENES" OR "CYCLOPARAFFINES" OR "POLYMETHYLENES"—MONOCYCLIC—SATURATED—SINGLE BONDS

Name.	Formula.	Melting-point, Deg. C.	Boiling-point, Deg. C.
Cyclopropane (Trimethylene).....	$\begin{array}{c} \text{CH}_2 \\ \diagup \quad \diagdown \\ \text{CH}_2 \end{array}$	-126	-35
Methylcyclopropane.....	$\begin{array}{c} \text{CH}_3 \\ \\ \text{CH} \\ \diagup \quad \diagdown \\ \text{CH}_2 \end{array}$	+ 4
Dimethyl-1-1-cyclopropane.....	$\begin{array}{c} \text{CH}_3 \\ \\ \text{C} \\ \\ \text{CH}_3 \end{array} \begin{array}{c} \diagup \quad \diagdown \\ \text{CH}_2 \\ \\ \text{CH}_2 \end{array}$	21
Trimethyl-1-1-2-cyclopropane.....	$\begin{array}{c} \text{CH}_3 \\ \\ \text{C} \\ \\ \text{CH}_3 \end{array} \begin{array}{c} \diagup \quad \diagdown \\ \text{CH} \cdot \text{CH}_3 \\ \\ \text{CH}_2 \end{array}$	56
Trimethyl-1-2-3-cyclopropane.....	$\begin{array}{c} \text{CH}_3 \\ \\ \text{CH} \\ \diagup \quad \diagdown \\ \text{CH} \cdot \text{CH}_3 \end{array}$	65
Cyclobutane (Tetramethylene).....	$\begin{array}{c} \text{CH}_2 - \text{CH}_2 \\ \quad \\ \text{CH}_2 - \text{CH}_2 \end{array}$	Below -80	11
Methylcyclobutane.....	$\begin{array}{c} \text{CH}_3 \cdot \text{CH} - \text{CH}_2 \\ \quad \\ \text{CH}_2 - \text{CH}_2 \end{array}$	40
Ethylcyclobutane.....	$\begin{array}{c} \text{C}_2\text{H}_5 \cdot \text{CH} - \text{CH}_2 \\ \quad \\ \text{CH}_2 - \text{CH}_2 \end{array}$	72
Cyclobutyldiethylmethane.....	$\begin{array}{c} \text{CH}_2 - \text{CH} - \text{CH} \\ \quad \quad \diagup \quad \diagdown \\ \text{CH}_2 - \text{CH}_2 \quad \text{C}_2\text{H}_5 \\ \quad \quad \quad \text{C}_2\text{H}_5 \end{array}$	153
Cyclopentane (Pentamethylene).....	$\begin{array}{c} \text{CH}_2 - \text{CH}_2 \\ \quad \diagup \quad \diagdown \\ \text{CH}_2 - \text{CH}_2 \quad \text{CH}_2 \end{array}$	Below -80	50

TABLE VIII—Continued.

Name.	Formula.	Melting-point, Deg. C.	Boiling-point, Deg. C.
Methylcyclopentane	$\begin{array}{c} \text{CH}_2-\text{CH}_2 \\ \\ \text{CH}_2-\text{CH}_2 \end{array} \begin{array}{l} \diagup \\ \diagdown \end{array} \begin{array}{l} \text{CH} \cdot \text{CH}_3 \\ \text{CH} \cdot \text{CH}_3 \end{array}$	72
Dimethyl-1-1-cyclopentane	$\begin{array}{c} \text{CH}_2-\text{CH}_2 \\ \\ \text{CH}_2-\text{CH}_2 \end{array} \begin{array}{l} \diagup \\ \diagdown \end{array} \begin{array}{l} \text{C} \\ \text{C} \end{array} \begin{array}{l} \diagup \\ \diagdown \end{array} \begin{array}{l} \text{CH}_3 \\ \text{CH}_3 \end{array}$	88
Dimethyl-1-2-cyclopentane	$\begin{array}{c} \text{CH}_2-\text{CH}_2 \\ \\ \text{CH}_2-\text{CH} \\ \text{CH}_3 \end{array} \begin{array}{l} \diagup \\ \diagdown \end{array} \begin{array}{l} \text{CH} \cdot \text{CH}_3 \\ \text{CH} \cdot \text{CH}_3 \end{array}$	93
Dimethyl-1-3-cyclopentane	$\begin{array}{c} \text{CH}_2-\text{CH}_2 \\ \\ \text{CH}-\text{CH}_2 \\ \text{CH}_3 \end{array} \begin{array}{l} \diagup \\ \diagdown \end{array} \begin{array}{l} \text{CH} \cdot \text{CH}_3 \\ \text{CH} \cdot \text{CH}_3 \end{array}$	91
Methyl-1-ethyl-2-cyclopentane	$\begin{array}{c} \text{CH}_2-\text{CH}_2 \\ \\ \text{CH}_2-\text{CH} \\ \text{C}_2\text{H}_5 \end{array} \begin{array}{l} \diagup \\ \diagdown \end{array} \begin{array}{l} \text{CH} \cdot \text{CH}_3 \\ \text{CH} \cdot \text{CH}_3 \end{array}$	124
Methyl-1-ethyl-3-cyclopentane	$\begin{array}{c} \text{CH}_2-\text{CH}_2 \\ \\ \text{C}_2\text{H}_5-\text{CH}-\text{CH}_2 \\ \text{CH}_3 \end{array} \begin{array}{l} \diagup \\ \diagdown \end{array} \begin{array}{l} \text{CH} \cdot \text{CH}_3 \\ \text{CH} \cdot \text{CH}_3 \end{array}$	120
Cyclohexane (Hexamethylene)	$\begin{array}{c} \text{CH}_2-\text{CH}_2-\text{CH}_2 \\ \\ \text{CH}_2-\text{CH}_2-\text{CH}_2 \end{array}$	+ 6	81
Methylcyclohexane	$\begin{array}{c} \text{CH}_3-\text{CH}-\text{CH}_2-\text{CH}_2 \\ \\ \text{CH}_2-\text{CH}_2-\text{CH}_2 \end{array}$	100
Dimethyl-1-1-cyclohexane	$\begin{array}{c} \text{CH}_3 \\ \diagup \\ \text{C} \\ \diagdown \\ \text{CH}_3 \end{array} \begin{array}{l} \text{---} \\ \text{---} \end{array} \begin{array}{l} \text{CH}_2-\text{CH}_2 \\ \text{CH}_2-\text{CH}_2-\text{CH}_3 \end{array}$	117
Dimethyl-1-2-cyclohexane	$\begin{array}{c} \text{CH}_3 \quad \text{CH}_3 \\ \quad \\ \text{CH}-\text{CH}-\text{CH}_2 \\ \\ \text{CH}_2-\text{CH}_2-\text{CH}_3 \end{array}$	126
Dimethyl-1-3-cyclohexane	$\begin{array}{c} \text{CH}_3 \quad \text{CH}_3 \\ \quad \\ \text{CH}-\text{CH}_2-\text{CH} \\ \\ \text{CH}_2-\text{CH}_2-\text{CH}_3 \end{array}$	119
Dimethyl-1-4-cyclohexane	$\begin{array}{c} \text{CH}_3-\text{CH}-\text{CH}_2-\text{CH}_2 \\ \quad \\ \text{CH}_2-\text{CH}_2-\text{CH}-\text{CH}_3 \end{array}$	120
Ethylcyclohexane	$\begin{array}{c} \text{C}_2\text{H}_5-\text{CH}-\text{CH}_2-\text{CH}_2 \\ \\ \text{CH}_2-\text{CH}_2-\text{CH}_2 \end{array}$	130

TABLE VIII—Continued.

Name.	Formula.	Melting-point, Deg. C.	Boiling-point, Deg. C.
Trimethyl-1-1-3-cyclohexane.....	$\begin{array}{c} \text{CH}_3 \\ \diagdown \\ \text{C} - \text{CH}_2 - \text{CH} \cdot \text{CH}_3 \\ \diagup \\ \text{CH}_3 \\ \\ \text{CH}_2 - \text{CH}_2 - \text{CH}_2 \end{array}$	137
Trimethyl-1-2-4-cyclohexane.....	$\begin{array}{c} \text{CH}_3 \quad \text{CH}_3 \\ \quad \\ \text{CH} - \text{CH} - \text{CH}_2 \\ \quad \quad \\ \text{CH}_2 - \text{CH}_2 - \text{CH} - \text{CH}_3 \\ \quad \quad \\ \text{CH}_3 - \text{CH} - \text{CH}_2 - \text{CH} - \text{CH}_3 \\ \quad \\ \text{CH}_2 - \text{CH} - \text{CH}_2 \end{array}$	143
Trimethyl-1-3-5-cyclohexane.....	$\begin{array}{c} \text{CH}_3 \\ \\ \text{CH}_2 - \text{CH} - \text{CH}_2 \\ \\ \text{CH}_3 \end{array}$	138
Methyl-1-ethyl-2-cyclohexane.....	$\begin{array}{c} \text{CH}_3 \quad \text{C}_2\text{H}_5 \\ \quad \\ \text{CH} - \text{CH} - \text{CH}_2 \\ \quad \\ \text{CH}_2 - \text{CH}_2 - \text{CH}_2 \end{array}$	151
Methyl-1-ethyl-3-cyclohexane.....	$\begin{array}{c} \text{CH}_3 - \text{CH} - \text{CH}_2 - \text{CH} - \text{C}_2\text{H}_5 \\ \quad \quad \\ \text{CH}_2 - \text{CH}_2 - \text{CH}_2 \end{array}$	149
Methyl-1-ethyl-4-cyclohexane.....	$\begin{array}{c} \text{CH}_3 - \text{CH} - \text{CH}_2 - \text{CH}_2 \\ \quad \\ \text{CH}_2 - \text{CH}_2 - \text{CH} - \text{C}_2\text{H}_5 \end{array}$	150
Propylcyclohexane.....	$\begin{array}{c} \text{C}_3\text{H}_7 - \text{CH} - \text{CH}_2 - \text{CH}_2 \\ \\ \text{CH}_2 - \text{CH}_2 - \text{CH}_2 \end{array}$	153
Methyl-1-isopropyl-4-cyclohexane (Menthane).....	$\begin{array}{c} \text{CH}_3 - \text{CH} - \text{CH}_2 - \text{CH}_2 \\ \quad \\ \text{CH}_2 - \text{CH}_2 - \text{CH} - \text{C}_3\text{H}_7 \end{array}$	169
Methyl-1-ethyl-3-isopropyl-4-cyclo- hexane.....	$\begin{array}{c} \text{CH}_3 - \text{CH} - \text{CH}_2 - \text{CH} - \text{C}_2\text{H}_5 \\ \quad \quad \\ \text{CH}_2 - \text{CH}_2 - \text{CH} - \text{C}_3\text{H}_7 \end{array}$	207
Diethyl-1-3-cyclohexane.....	$\begin{array}{c} \text{C}_2\text{H}_5 - \text{CH} - \text{CH}_2 - \text{CH} - \text{C}_2\text{H}_5 \\ \quad \\ \text{CH}_2 - \text{CH}_2 - \text{CH}_2 \end{array}$	170
Cycloheptane (Suberane).....	$\begin{array}{c} \text{CH}_2 - \text{CH}_2 - \text{CH}_2 \\ \quad \quad \\ \text{CH}_2 - \text{CH}_2 - \text{CH}_2 \end{array} \begin{array}{l} \diagup \\ \text{CH}_2 \\ \diagdown \end{array}$	117
Cyclo-octane (Octomethylene).....	$\begin{array}{c} \text{CH}_2 - \text{CH}_2 - \text{CH}_2 - \text{CH}_2 \\ \quad \quad \quad \\ \text{CH}_2 - \text{CH}_2 - \text{CH}_2 - \text{CH}_2 \end{array}$	11	148
Cyclo-nonane (Nonomethylene).....	$\begin{array}{c} \text{CH}_2 - \text{CH}_2 - \text{CH}_2 - \text{CH}_2 \\ \quad \quad \quad \\ \text{CH}_2 - \text{CH}_2 - \text{CH}_2 - \text{CH}_2 \end{array} \begin{array}{l} \diagup \\ \text{CH}_2 \\ \diagdown \end{array}$	171

These occur largely in Russian (Baku) petroleum, in American mixed-base, and asphaltic petroleums (including Ohio, California and Canadian), in certain South American petroleums (Peru and Colombia) and in Borneo petroleum.

C_nH_{2n-2} SERIES—SATURATED—SINGLE BONDS—POLYCYCLIC—“POLYCYCLIC POLYMETHYLENES”

The most important members of this series are given in the following table:

TABLE IX.— C_nH_{2n-2} SERIES—“POLYCYCLIC POLYMETHYLENES”—POLYCYCLIC—SATURATED—SINGLE BONDS

Name.	Formula.	Melting-point, Deg. C.	Boiling-point, Deg. C.
Dihydropinene (Pinane) Trimethyl-2-7-7-bicyclo-1-1-3-heptane	$ \begin{array}{c} \text{CH}_2 \quad \quad \text{CH} - \text{CH} - \text{CH}_3 \\ \quad \quad \quad \diagdown \quad \diagup \\ \quad \quad \quad \text{C} \quad \quad \quad \text{CH}_2 \\ \quad \quad \quad \diagup \quad \diagdown \\ \text{CH}_3 \quad \quad \text{CH} - \text{CH}_2 \end{array} $	116
Trimethyl-1-7-7-bicyclo-1-2-2-heptane (Camphane)	$ \begin{array}{c} \text{CH}_3 \\ \\ \text{CH}_2 - \text{C} - \text{CH}_2 \\ \quad \quad \\ \text{CH}_3 - \text{C} - \text{CH}_3 \\ \\ \text{CH}_2 - \text{C} - \text{CH}_2 \\ \\ \text{H} \end{array} $	153	161
Bicyclononane.....	$ \begin{array}{c} \text{CH}_2 - \text{CH}_2 - \text{CH} - \text{CH}_2 \\ \quad \quad \quad \quad \\ \text{CH}_2 - \text{CH}_2 - \text{CH} - \text{CH}_2 \quad \text{CH}_2 \end{array} $	163
Dekahydronaphthalene.....	$ \begin{array}{c} \text{CH}_2 - \text{CH}_2 - \text{CH} - \text{CH}_2 - \text{CH}_2 \\ \quad \quad \quad \quad \quad \quad \\ \text{CH}_2 - \text{CH}_2 - \text{CH} - \text{CH}_2 - \text{CH}_2 \end{array} $	188
Methyl-1-bicyclo-1-3-3-nonane.....	$ \begin{array}{c} \text{CH}_3 \\ \\ \text{CH}_2 - \text{C} - \text{CH}_2 \\ \quad \quad \quad \quad \\ \text{CH}_2 \quad \text{CH}_2 \quad \text{CH}_2 \\ \quad \quad \quad \quad \\ \text{CH}_2 - \text{CH} - \text{CH}_2 \end{array} $	177

These hydrocarbons are usually associated with the monocyclic C_nH_{2n} Series.

C_nH_{2n-2} SERIES—UNSATURATED—ONE DOUBLE BOND—MONOCYCLIC—“CYCLO-OLEFINES”

These include cyclo-ethylene, C_4H_6 , $CH=CH$ and cyclo-propylene, C_5H_8 , $CH=CH$
 $CH_2-CH_2-CH_2$ which occur largely in Texas oils and in certain asphalts.

C_nH_{2n-4} SERIES—UNSATURATED—TWO DOUBLE BONDS—MONOCYCLIC—“TERPENES”

These include the substances limonene, dipentene, terpinolene, terpinene, sylvesterene, etc., and are found in Java, Sumatra, Baku, Galicia and Texas

(Beaumont) petroleum in relatively small amounts. They also constitute the so-called "essential oils."

C_nH_{2n-4} SERIES—SATURATED—SINGLE BONDS—"POLYCYCLIC POLYNAPHTHENES"

These are found in Texas (Beaumont), Louisiana, California, and Ohio petroleum, of which the principal members are shown in Table X.

TABLE X.— C_nH_{2n-4} SERIES—"POLYCYCLIC POLYNAPHTHENES"—POLYCYCLIC SATURATED—SINGLE BONDS

Name.	Formula.	Melting-point, Deg. C.	Boiling-point, Deg. C.
Perhydroacene.....	$\begin{array}{c} CH_2 - CH_2 \\ \quad \\ CH_3 \cdot CH \cdot CH \cdot CH \cdot CH_3 \\ \quad \quad \quad \\ CH_2 \cdot CH_2 \cdot CH \cdot CH_2 \cdot CH_2 \\ \quad \quad \quad \quad \\ CH_2 \cdot CH_2 \cdot CH \cdot CH \cdot CH_2 \cdot CH_3 \\ \quad \quad \quad \quad \\ CH_3 \cdot CH_2 \cdot CH \cdot CH \cdot CH_2 \cdot CH_3 \end{array}$	235
Perhydrofluorene.....	$\begin{array}{c} CH_3 \\ \diagdown \quad / \\ CH_2 \cdot CH_2 \cdot CH \cdot CH \cdot CH_2 \cdot CH_3 \\ \quad \quad \quad \\ CH_3 \cdot CH_2 \cdot CH \cdot CH \cdot CH_2 \cdot CH_3 \end{array}$	230
Perhydrophenanthrene.....	$\begin{array}{c} CH_3 \cdot CH_2 \cdot CH - CH \cdot CH_2 \cdot CH_3 \\ \quad \quad \quad \quad \\ CH_3 \cdot CH_2 \cdot CH \quad CH \cdot CH_2 \cdot CH_3 \\ \quad \\ CH_2 - CH_2 \end{array}$	272
Perhydroanthracene.....	$\begin{array}{c} CH_2 \cdot CH_2 \cdot CH \cdot CH_2 \cdot CH \cdot CH_2 \cdot CH_2 \\ \quad \quad \quad \quad \quad \\ CH_2 \cdot CH_2 \cdot CH \cdot CH_2 \cdot CH \cdot CH_2 \cdot CH_2 \end{array}$	88	270
β -Tricyclodekane.....	$\begin{array}{c} CH_2 - CH - CH - CH_2 \\ / \quad \quad \backslash \\ CH_2 \quad \quad \quad CH_2 \\ \backslash \quad \quad / \\ CH_2 - CH - CH - CH_2 \end{array}$	9

C_nH_{2n-6} SERIES—UNSATURATED—THREE DOUBLE BONDS—MONOCYCLIC—"BENZENES"

The benzenes constitute one of the most important series of hydrocarbons, and form the basis for many valuable organic compounds, including the "coal tar" dyes and drugs. The lowest member of this series is the hydrocarbons benzol or benzene, C_6H_6 . Its exact structure is represented by the following diagram:

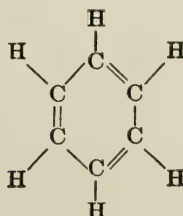

Which, for the sake of convenience, is abbreviated by the following symbol:



“This is known as the “benzol ring,” consisting of six carbon atoms joined together with single and double bonds alternately, and each united with a single atom of hydrogen.

The principal members of the benzene series, C_nH_{2n-6} , are shown in the following table:

TABLE XI.— C_nH_{2n-6} SERIES—“BENZENES”—MONOCYCLIC—UNSATURATED—DOUBLE BONDS

C_6H_6	C_6H_6 Benzol (B.P. = 80° C.)			
C_7H_8	$C_6H_5 \cdot CH_3$ Toluol (110°)			
C_8H_{10}	$C_6H_4(CH_3)_2$ Xyloles (3) (Ortho = 142°; Meta = 139°; Para = 138°)		$C_6H_5 \cdot C_2H_5$ Ethyl-benzol (134°)	
C_9H_{12}	$C_6H_5CH_2$ Trimethylbenzoles (3) 1-3-5 = Mesitylene (163°) 1-2-4 = Pseudocumene (169°) 1-2-3 = Hemimellitene (175°)	$C_6H_4(CH_3)(C_2H_5)$ Ethylmethylbenzoles (3) (Ethyltoluoles)	$C_6H_5 \cdot (C_2H_5)$ Propylbenzoles (2) Normal-propyl-benzole (157°) Isopropyl-benzole (153°)	
$C_{10}H_{14}$	$C_6H_2(CH_3)_4$ Tetramethylbenzoles (3) 1-2-4-5 = Durene (190°) 1-2-3-5 = Isodurene (195°) 1-2-3-4 = Prehnitol (204°)	$C_6H_3(CH_3)_2(C_2H_5)$ Ethyl-dimethylbenzoles (6 isomers possible)	$C_6H_4(C_2H_5)_2$ Diethylbenzoles (3 isomers possible)	$C_6H_5(C_4H_9)$ Butylbenzoles (4 isomers possible)
			$C_6H_4(CH_3)(C_2H_5)$ Methylpropylbenzoles (6 isomers possible) 1-4 = Cymene (176°)	
$C_{11}H_{16}$	$C_6H(CH_3)_5$ Pentamethylbenzol (231°); $C_6H_5(C_5H_{11})$ Amylbenzol; etc.			
$C_{12}H_{18}$	$C_6(CH_3)_6$ Hexamethylbenzol (264°); $C_6H_3(C_2H_5)_3$ Triethylbenzol; etc.			
$C_{14}H_{22}$	$C_6H_5(C_8H_{17})$ Octylbenzol; $C_6H_2(C_2H_5)_4$ Tetraethylbenzol.			
$C_{18}H_{30}$	$C_6(C_2H_5)_6$ Hexaethylbenzol (305°).			

Members of the benzene series are present in coal tars, water-gas tar and other high-temperature distillates. Coal tars, however, constitute the most prolific source of the benzenes. They are present to a small extent in lignite tar, and only in very small quantities in petroleum. Traces have been identified in petroleum obtained from Borneo, Sumatra, Java, Japan, and to a very small extent in certain varieties from California.

C_nH_{2n-8} TO C_nH_{2n-30} SERIES—UNSATURATED—MONOCYCLIC AND POLYCYCLIC

These are grouped together for the sake of convenience. A brief description will be given of the respective series, together with their principal members.

C_nH_{2n-8} Series, of which the principal member is phenylethylene, $C_6H_5 \cdot CH : CH_2$. This series is composed of the benzol nucleus with an unsaturated side chain.

C_nH_{2n-10} Series, of which the principal member is phenylacetylene, $C_6H_5 \cdot C : CH$. This series is composed of the benzol nucleus with a side chain corresponding to the acetylene series. It is not of importance.

C_nH_{2n-12} Series, known as the "naphthalenes."

The principal member of this series is naphthalene, $C_{10}H_8$, which is represented graphically as:

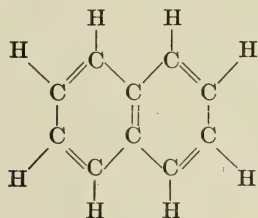

And for the sake of brevity, by the symbol:



Naphthalene has a crystalline structure and a characteristic odor. It is found principally in coal tar. Other members of this series are methyl naphthalene, $C_{10}H_7 \cdot CH_3$, dimethyl naphthalene, $C_{10}H_6(CH_3)_2$, ethyl naphthalene, $C_{10}H_7 \cdot C_2H_5$, etc.

C_nH_{2n-14} Series, known as the "diphenyls."

The principal member of this is diphenyl, $C_{12}H_{10}$, which is represented graphically by the following formula:



The next member of this series is methyl diphenyl, $C_{13}H_{12}$. The C_nH_{2n-14} hydrocarbons also include the acenaphthene series, which is an isomer of the preceding. The first member of this series is known as acenaphthene, $C_{12}H_{10}$, which is represented graphically as follows:



C_nH_{2n-16} Series, including the diphenylenes of which the first member is fluorene, $C_{13}H_{10}$:

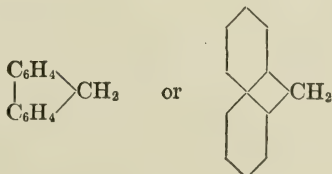

This series also includes the substance known as stilbene (diphenylethylene) $C_6H_5 \cdot CH : CH \cdot C_6H_5$.

C_nH_{2n-18} Series, known as "anthracenes," of which anthracene, $C_{14}H_{10}$ is the principal member. Anthracene may be illustrated graphically by the following formula:

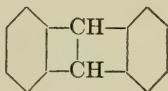

Retene is also a member of this series.

C_nH_{2n-20} Series, of which "fluoranthene," $C_{15}H_{10}$ is the principal member.

C_nH_{2n-22} Series, of which "pyrene," $C_{16}H_{10}$, is the principal member.

C_nH_{2n-26} Series, of which "dinaphthyl," is the principal member.

C_nH_{2n-28} Series, of which no members have been isolated.

C_nH_{2n-30} Series, known as the "picenes," of which picene, $C_{22}H_{14}$, is the principal member. Picene is the highest melting-point hydrocarbon which has been isolated. It melts at $364^\circ C.$, and occurs in lignite tar, coal tar and certain petroleum residues.

The hydrocarbons of the series C_nH_{2n-8} to C_nH_{2n-30} occur in coal tar, and to a smaller extent in lignite tar and petroleum residues.

OXYGENATED BODIES

These include the following substances:

Water, H_2O . This occurs in small quantities in all native petroleum and in most native asphalts, especially those associated with mineral matter. Water is always present in crude tars, being formed by the combination of hydrogen and oxygen at high temperatures.

Alcohols. The principal members are methyl alcohol, CH_3OH , also known as wood alcohol, which is found in substantial quantities in wood tar, also ethyl alcohol, C_2H_5OH , which is also present, but in very small amounts.

Acetone, $CH_3 \cdot CO \cdot CH_3$. This substance and its homologues are found in small quantities in wood tar, coal tar, and lignite tar.

Fatty Acids. Acetic acid, $CH_3 \cdot COOH$, is present in wood tars, and particularly those derived from hard woods. Acetic acid belongs to the series $C_nH_{2n+1} \cdot COOH$. The higher melting-point acids of this series including palmitic acid, $CH_3(CH_2)_{14} \cdot COOH$, stearic acid, $CH_3(CH_2)_{16} \cdot COOH$, and the corresponding esters and lactones are found in fatty-acid pitches.

Resin Acids. These are found in pine tar and pine-tar pitch. The composition of these acids has not yet been definitely determined. They are also present to a large extent in resin pitch.

Phenols. The important members of this class of substances are phenol or carboic acid, $C_6H_5 \cdot OH$, cresol or methyl phenol, $CH_3 \cdot C_6H_4 \cdot OH$, of which there are three isomers. These and the higher members of this series are present in coal tar and lignite tar.

OXYGENATED BODIES OF UNKNOWN COMPOSITION

Many substances containing oxygen of which the exact composition has not yet been determined are present in the non-asphaltic pyrobitumens, also to a small extent in tars, pitches, and asphaltites.

NITROGENOUS BODIES

Ammonia, NH_3 , and ammonium compounds are found in coal tar.

Pyridine, $\text{C}_5\text{H}_5\cdot\text{N}$ or , and derivatives of pyridine including methyl pyridine (also known as picolin, $\text{CH}_3\cdot\text{C}_5\text{H}_4\cdot\text{N}$), dimethyl pyridine, etc., are found in coal tar, lignite tar, petroleum asphalts and pitches.

Quinoline, $\text{C}_8\text{H}_7\text{N}$, and its derivatives are also present in these materials.

NITROGENOUS BODIES OF UNKNOWN COMPOSITION

These are present in petroleum, asphalts, pyrobitumens, tars and pitches, in relatively small quantities.

SULPHURATED BODIES

The exact chemical composition of the substances containing sulphur has not yet been thoroughly investigated. There are, however, numerous sulphurous compounds in bitumens, pyrobitumens, tars and pitches, including the mercaptanes, thiophenes, and their derivatives, also substances of analogous composition. Small amounts of hydrogen sulphide, H_2S , are found associated with petroleum and asphalt, and in the distillates of coal and lignite.

It will be gathered from the preceding that the chemistry of bituminous substances is very complicated, due to the fact that no commercial product has a definite composition, but consists of mixtures of numerous chemical substances in varying proportions. At the present time certain of these substances have been identified, but there is still a vast amount of work to be done in arriving at the exact composition of the individual chemical bodies present in bituminous substances. Although comparatively little is known regarding the exact chemical substances present in coals and asphalts, the composition of petroleum and various tars has been largely unravelled. Hundreds of definite chemical substances have been identified in petroleum, and hundreds have been separated from coal tar. No two petroleum are alike in composition. In some, certain chemical substances predominate, in others they are absent, or present in smaller amounts. The same holds true with tars, pitches, and asphalts. In certain cases, comparatively simple methods have been devised for identifying *single* chemical bodies present and thus furnish a means of ascertaining the origin of the substance under examination.

PERCENTAGES OF THE ELEMENTS PRESENT IN BITUMINOUS SUBSTANCES

Bituminous substances are composed of the following elements: carbon, hydrogen, oxygen, sulphur, and nitrogen. It is comparatively simple by analytical methods to determine the mere percentages of the elements present. An expression of the percentages of the elements present in a substance is termed its *ultimate analysis*, in contra-distinction to its *exact chemical composition*. The ultimate analysis will often furnish a clue as to its identity.

The element nitrogen is rarely present in excess of 2 per cent of the non-mineral constituents. Mineral waxes are usually free from nitrogen. Petroleum, asphalt,

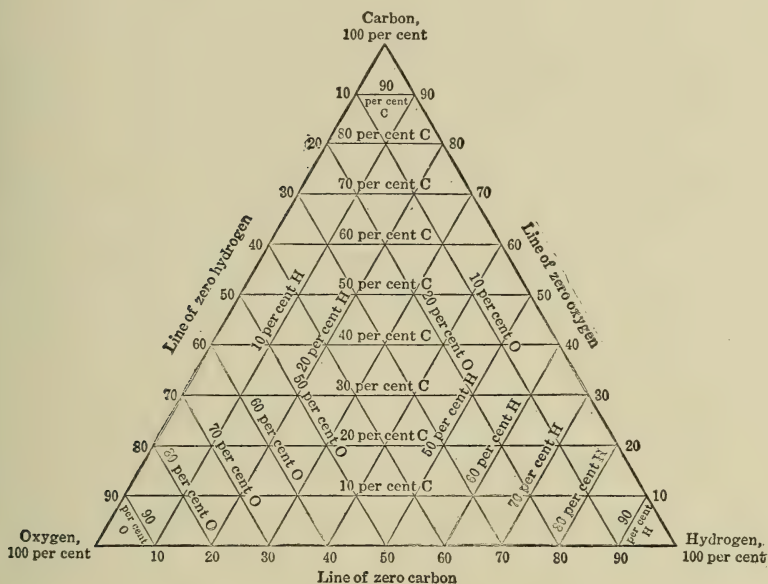

FIG. 11.—Trilinear Coordinates on an Equilateral Triangle.

asphaltites and pyrobitumens contain amounts varying from a trace to 1.7 per cent of nitrogen. Tars and pitches contain from 0 to 1 per cent of nitrogen.

The percentage of sulphur in bituminous materials varies considerably. Ozokerite, paraffine wax, montan wax, coal tar, coal-tar pitch, pine tar, pine-tar pitch, hardwood tar, hardwood-tar pitch, and fatty-acid pitch are practically free from sulphur.

In petroleum, the sulphur varies from a trace to 5 per cent as a maximum. Mexican petroleum contains between 3 and 5 per cent. Trinidad and California petroleums contain approximately $\frac{1}{2}$ to 4 per cent. Mixed-base petroleums including the Mid-continental and Texas oils contain from a trace to about $2\frac{1}{2}$ per cent. Paraffineous petroleums contain merely a trace. Residual oils contain from a trace to 5 per cent.

Residual asphalt, blown asphalt, sludge asphalt, native asphalts, asphaltites, asphaltic pyrobitumens, and non-asphaltic

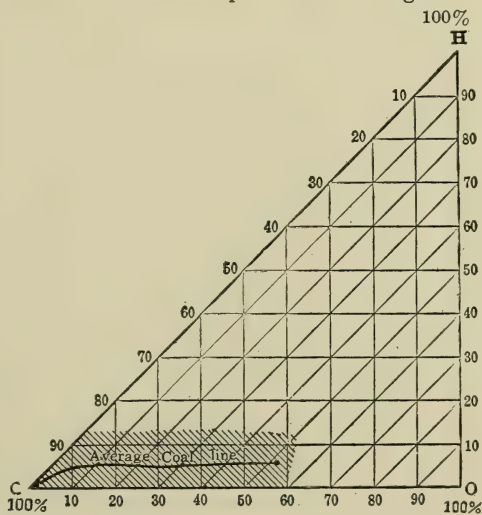

FIG. 12.—Trilinear Coordinates on an Isosceles Triangle.

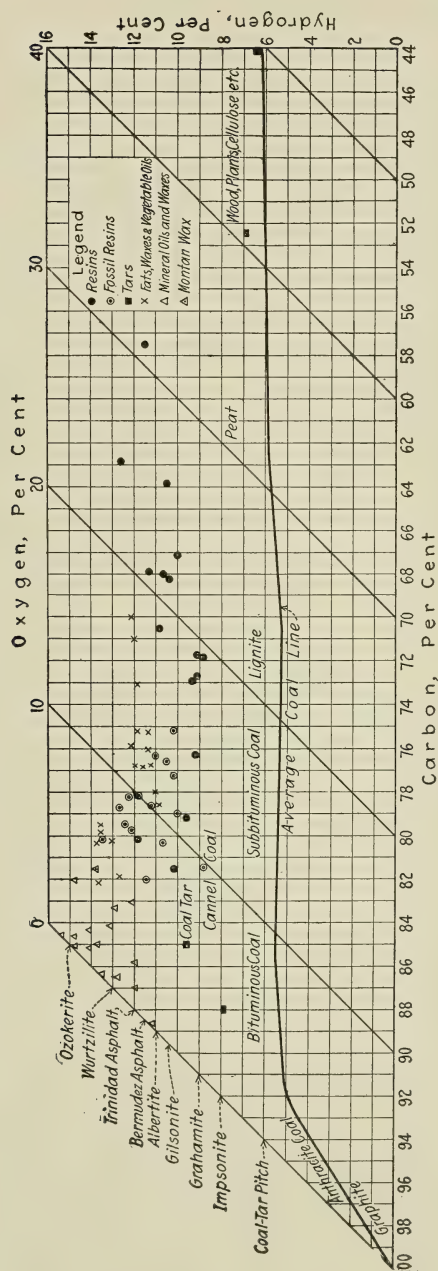

Fig. 13.—Percentages of Carbon, Hydrogen and Oxygen in Typical Bituminous Substances.

pyrobitumens contain from a trace to 10 per cent of sulphur. Tars and pitches derived from non-asphaltic pyrobitumens contain from a trace to $1\frac{1}{2}$ per cent.

As far as we can determine, the presence of nitrogen and sulphur vary according to no known laws and may therefore be regarded as adventitious. On the other hand, the percentages of carbon, hydrogen, and oxygen appear to follow well-defined laws, and may be used as criteria to differentiate between the various classes of bituminous materials. The investigations of O. C. Ralston¹ have done much to clear up this subject. Analyses are first calculated to a moisture-free, ash-free, nitrogen-free, and sulphur-free basis, so that the percentages of carbon, hydrogen, and oxygen will add up to 100 per cent. The results are then plotted on a special type of trilinear coordinates.

To explain this we will first refer to the usual form of trilinear coordinates adapted to substances composed of the three elements carbon, hydrogen, and oxygen, illustrated in Fig. 11. It is more convenient, however, to use an isosceles right-angle triangle as shown in Fig. 12. Since none of the bituminous substances contain more than 15 per cent of hydrogen, only the part of the triangle represented by the shaded section in the preceding illustration need be used. Fig. 13 shows the shaded portion of Fig. 12 drawn on an enlarged scale, on which are plotted the typical bituminous substances.

The percentages of oxygen contained in the more important bituminous materials (calculated on the mineral-free basis) are shown in Table XXXV on page 483. With the exception of the non-asphaltic pyrobitumens, the percentage of oxygen

¹ Technical Paper No. 93. U. S. Department of Interior, Bureau of Mines, Wash., D. C. 1915.

does not exceed 5. This is significant. The hydrogen, on the other hand, never exceeds 15 per cent. In the paraffine series of hydrocarbons, the carbon is combined with as much hydrogen as possible, and this accordingly contains the largest percentage of hydrogen and the smallest percentage of carbon. The lowest member of this series CH_4 , a gas, contains 75 per cent of carbon and 25 per cent of hydrogen. The member $\text{C}_{30}\text{H}_{62}$ contains 85.31 per cent of carbon and 14.69 per cent of hydrogen. In the olefine series C_nH_{2n} , the relation of carbon to hydrogen is constant, and figures: carbon 85.71 per cent and hydrogen 14.29 per cent.

The greatest percentage of carbon found in any bituminous substance is in the case of anthracite coal, which runs as high as 98 per cent. The smallest percentage is contained in certain peats, which run as low as 50 per cent. With the exception of the non-asphaltic pyrobitumens, carbon ranges from 85 to 95 per cent.

CHAPTER IV

GEOLOGY AND ORIGIN OF BITUMENS AND PYROBITUMENS

GEOLOGY

Age of the Geological Formations. The earth's crust has been divided into natural groups or strata in the order of their antiquity. There are five main divisions, which range in sequence as follows:

1. Quarternary or Post-tertiary, representing the strata now in the process of formation.
2. Tertiary or Cænozoic, embracing the age of recent life.
3. Secondary or Mesozoic, representing the less recent life.
4. Primary or Paleozoic, representing the so-called "ancient life."
5. Archæan or Azoic, representing the so-called lifeless strata.

These divisions are recognized by the distinctive organic remains, fossils, minerals and other characteristics. They are classified into various "systems" as shown in Table XII on the opposite page.

The systems form a chronological time-chart indicating the relative ages of the earth's strata. The systems are further sub-divided into groups which differ in different localities, but it will be unnecessary to consider their sub-classification here.

Petroleum occurs in all of the geological systems from the Recent down to the Pre-Cambrian. Certain systems are richer than others, especially the Pliocene, Miocene, Oligocene, Eocene, Carboniferous, Upper Devonian and Lower Silurian (Ordovician). Asphalts, asphaltites and non-asphaltic pyrobitumens are found in all the systems from the Pliocene to the Silurian. Mineral waxes are found largely in the Pliocene, Miocene, Oligocene, Eocene and Cretaceous.

The non-asphaltic pyrobitumens do not occur in the older Paleozoic formations (i.e. the Silurian or Cambrian Systems). The Carboniferous System contains the most valuable coal deposits; the Permian and Triassic Systems contain coals of inferior quality, and the coals found in the Jurassic, Cretaceous, Eocene and Oligocene Series are still more inferior in quality. Lignite occurs in the Oligocene, and Miocene Series, and peat in the Pliocene and Pleistocene. The Pre-Cambrian Series consists largely of crystalline, metamorphic rocks of volcanic and igneous

origin. The non-asphaltic pyrobitumens, as might be expected, do not occur in rocks of this character. Graphite, however, occurs in the Pre-Cambrian rocks, and may possibly have been derived from vegetable matter, although no signs of associated plant remains have been found in these rocks.

TABLE XII

ERA.	SYSTEM.		
Quarternary or Post-tertiary.....	{ Recent or Post-glacial Pleistocene or Glacial	{ Historic Prehistoric Neolithic	
Tertiary or Cænozoic....	{ Pliocene Miocene Oligocene Eocene		
Secondary or Mesozoic....	{ Cretaceous... Jurassic....	{ Upper Middle Lower Upper Middle Lower	
	{ Permian Carboniferous	{ Upper Lower Upper Middle Lower	
Primary or Paleozoic.....	{ Devonian.... Silurian....	{ Upper Middle Lower Upper Lower (Ordovician)	
	{ Cambrian....	{ Upper Middle Lower	
Archæan or Azoic.....	Pre-Cambrian		

The particular geological system is of value in enabling us to prospect and trace deposits of bitumens and pyrobitumens in any given locality.

Character of the Associated Minerals. Bitumens and pyrobitumens, with but few exceptions, are found in sedimentary deposits of sand, sandstone, limestone and sometimes in shale and clay. Rare occurrences have been reported in igneous rocks, but then only in very small quantities.

Modes of Occurrence. Bitumens and pyrobitumens are found in nature in the following ways:

1. Overflows:

- (a) Springs.
- (b) Lakes.
- (c) Seepages.

2. Impregnating Rocks:

- (a) Subterranean pools or reservoirs.
- (b) Horizontal rock strata.
- (c) Vertical rock strata.

3. Filling Veins:

- (a) Caused by vertical cleavage.
- (b) Caused by upturning.
- (c) Caused by sliding.
- (d) Formed by sedimentation.

Springs. Petroleum and the liquid forms of asphalt only are found in springs (Fig. 14). These emanate from a fissure, crevice, or fault which permits the petroleum or liquid asphalt to rise to the surface from some depth. Petroleum or asphalt springs have been reported in various parts of the world, but are rarely of commercial importance.

Lakes. Asphalt only is sometimes found in lakes, which are in reality springs on a very large scale (Fig. 15). Some of our largest and most valuable deposits occur in this form, the best known being the lakes at Trinidad and Venezuela. It is probable that the asphalt is forced up from below in a liquid or semi-liquid condition by the pressure of the oil and gas underneath, which causes it to flow through a fissure or fault and spread over a large area at the surface. Lake asphalts are moderately soft where they emanate, but harden on exposure to the elements.

Seepages. These occur in the case of petroleum or liquid asphalts, and usually from cliffs or mountains bearing impregnated rock. Either the pressure of the material itself or the heat of the sun causes a certain quantity, usually not very large, to flow out of the rock and run towards the lower level. (Fig. 16.) Seepages are often found where a rapidly flowing stream of water cuts its way through strata of rock impregnated with petroleum or asphalt. From a commercial standpoint, seepages of asphalt or petroleum are of little value.

Subterranean Pools or Reservoirs. Practically all deposits of petroleum of any magnitude occur below the surface of the earth in subterranean "pools" or "reservoirs." These consist of porous sand, sandstone, limestone (or dolomite) with a more or less impervious rock cover. The porous bed is exemplified by coarse-grained sandstone, conglomerate, or limestone. The limestone may have been dense as it existed originally, but rendered porous in the course of time by conversion into dolomite, with the consequent production of voids due to shrinkage, since dolomite occupies less space than the original limestone. The petroleum is carried in the interstices of the porous rock and prevented from volatilizing or escaping by an impervious cover known as the "cap-rock," usually composed of shale or a dense limestone. The main supplies of petroleum have been obtained from regions which have been comparatively undisturbed by terrestrial movements. In such cases the accumulation of petroleum underneath forms what is known as a "pool" or "reservoir" (Fig. 17).

Impregnated Rock in Strata. Liquid to semi-liquid asphalts occur in this manner. Rocks impregnated with asphalt are produced in two ways, viz.:

- (1) By the gradual evaporation and hardening of an asphaltic petroleum due

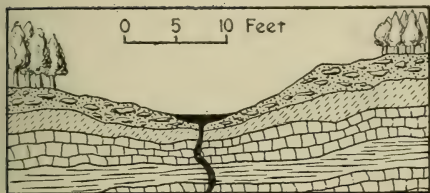

Spring
FIG. 14

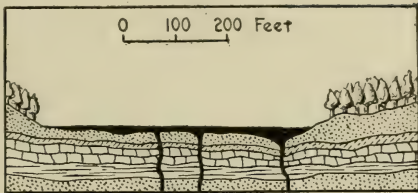

Lake
FIG. 15

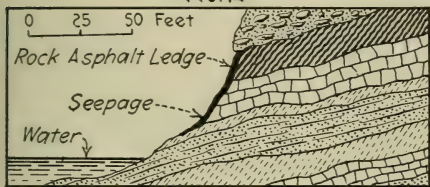

Seepages
FIG. 16

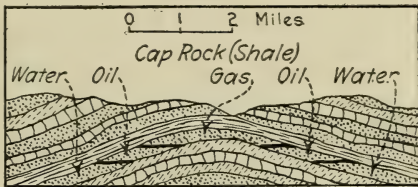

Subterranean Pool or Reservoir
FIG. 17

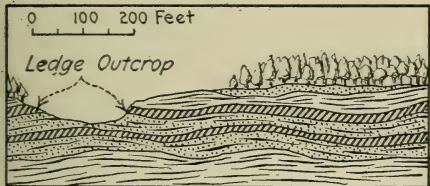

Impregnated Horizontal Strata
FIG. 18

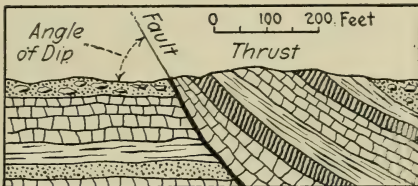

Impregnated Strata in Thrust
FIG. 19

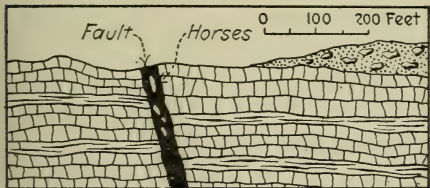

Fault Filling caused by Clearage
FIG. 20

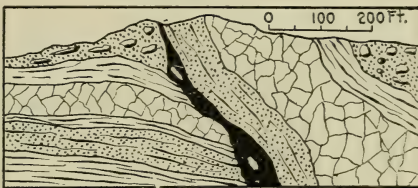

Fault Filling caused by Upturning
FIG. 21

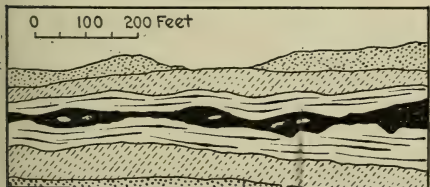

Vein Filling caused by Sliding of Strata
FIG. 22

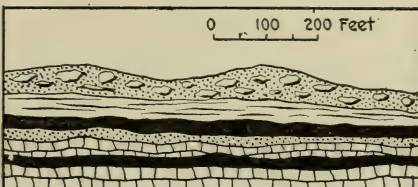

Veins formed by Sedimentation
FIG. 23

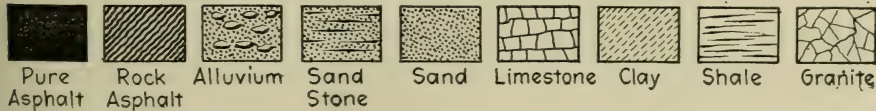

perhaps to the disturbing or removal of the cap-rock, leaving the asphalt residue filling the interstices of the stratum carrying it. These are usually found in horizontal strata (Fig. 18).

(2) By the liquid asphalt being forced upward under pressure, or drawn upward by capillarity from underlying strata into a porous rock layer above it. These are usually found in the region of a "thrust" or upturning of the earth's strata (Fig. 19).

Filling Veins. The harder asphalts, asphaltites and asphaltic pyrobitumens are most commonly found filling fissures in a more or less vertical direction, caused by "faulting." In geology, a "fault" is a more or less vertical crack in the earth's surface brought about by the contraction and uneven settling of the strata. This is occasioned by a greater movement in the rock on one side of the fault's plane than on the other, as illustrated in Fig. 20, or by the upturning of a section of the earth's crust as shown in Fig. 21. Faults allow the liquid or molten asphalt to force its way up from underneath and fill the crevice. As will be described later, after the asphalt hardens in the fault, it might in time become metamorphosized and converted into an asphaltite or asphaltic pyrobitumen. Non-asphaltic pyrobitumens are never found in faults, probably because they are incapable of softening or melting under the action of heat, either in their original state or afterwards.

Sometimes we find the harder asphalts, asphaltities and asphaltic pyrobitumens filling a more or less horizontal fissure or cleavage crack, brought about by the sliding of two strata, one upon the other. The opening between the strata becomes filled with the liquid or melted asphalt, forced up under pressure through a crevice from below, which then hardens, giving rise to a horizontal vein as shown in Fig. 22.

Horizontal veins are sometimes derived from prehistoric asphalt "lakes," perhaps similar to our present Trinidad or Venezuela lakes. In time, these harden, and become submerged in water, due perhaps to a movement in the level of the earth's crust. The water permits the sedimentation of mineral matter, so that the lake is gradually converted into a horizontal vein. If the liquid asphalt again breaks through a fault or fissure, it will form a superimposed vein, or perhaps a series of such veins between sediments, as shown in Fig. 23.

In the case of non-asphaltic pyrobitumens, the veins were unquestionably formed by a process of sedimentation. The vegetation from which these were derived, originally grew in swampy or marshy localities, presumably about the mouths of rivers. As the vegetation died, it became covered with sediments of sand or clay carried down by the water, or by calcium carbonate precipitated from the water, which in turn formed soil for subsequent growths. These gave rise to the future veins of non-asphaltic pyrobitumens, which are similar structurally to the preceding (Fig. 23).

Movement of Bitumens in the Earth's Strata. It is a singular fact that petroleum, mineral waxes, asphalts and asphaltites are not always found in the same locality in which they originated. They have the power of migrating from place to place, and many deposits are still in the process of migration. A "primary deposit" is one in which the bituminous material is still associated with the same rocks in which it originated. A "secondary deposit" is one to which the material has subsequently

migrated. Bitumens usually migrate while in a liquid or melted condition, although in certain rare instances the migration has been induced by the action of flowing water while the bitumen is in the solid state.

The main causes for the movement of native bituminous substances in the earth's surface are as follows:

(1) *Hydrostatic Pressure.* This is largely responsible for the accumulation of petroleum in pools or reservoirs. At some distance below the earth's surface there is an accumulation of ground water, the level of which varies in different localities and during different seasons. The petroleum, being lighter than the water, floats on its surface. As the level of the ground water varies, it will move the petroleum about through interstices in the rock. The water tends to push the oil ahead of it, and this will account for the accumulation of the petroleum in the form of pools or reservoirs underneath a cap of a dense and non-porous strata through which it cannot permeate. This will also explain why there is often an accumulation of petroleum in the ground near the top of a hill or mountain. Oil and gas are often encountered under pressure, due to the hydrostatic head of water.

Hydrostatic pressure may also cause the migration of solid asphalts, as for example in the case of the Dead Sea, where masses become detached from the bottom and are caused to float upward by the higher gravity of the water, due to the large percentage of salt dissolved in it.

(2) *Gas Pressure.* It is probable that the action of the heat or other forces below the surface of the earth, tend to partially vaporize certain bitumens, so that the resulting gas will force them into the overlying strata near the surface. In other instances the effect of faulting, crumpling, upturning, erosion and other movements of the earth's strata exposes the oil- or asphalt-bearing formations, and enables the gas pressure to force them to the surface. Natural gas exists under great pressure in certain localities. Many gas wells in the Baku and Pennsylvania fields have registered a pressure of 600 to 800 lb., and even as high as 1000 lb. per square inch. This may be accounted for by the fact that as the gas is constantly being generated, it accumulates inside of the earth's surface and has no access to escape owing to the density of the strata above.

(3) *Capillarity.* This force takes place in dry porous rocks and acts on permanently liquid bitumens, or bitumens solid at ordinary temperatures but transformed to the melted state by the action of heat. Under these conditions the bitumen will soak into the pores of the rock or sand and gradually fill the interstices. Capillarity is a very much stronger force than gravity, although other forces, such as the action of heat (see under 5) may be partly responsible. The finer the pores in the rock, the greater the capillary force. Rocks saturated with moisture tend to resist the action of capillarity, which is most effective in the dry state.

(4) *Gravitation.* The natural weight of the overlying strata caused by gravitation sets up a pressure where there are accumulations of petroleum or other forms of liquid bitumen underneath, and if a fissure or fault occurs in the earth's crust, the bitumen being softer than the surrounding rock, will be forced to the surface. Gravitation is therefore selective in its action and by exerting a greater pull on the heavier bodies will tend to force the lighter ones upward. Under other circumstances, where the substances are not confined, the result of gravitation is to cause the petroleum or liquid asphalt to ooze from the over-lying rock matrix in the form of "seepages."

(5) *Effect of Heat.* Heat is also a large factor in causing the migration of bituminous substances. Its effect is variable. Under certain circumstances it will convert the solid bitumens into a liquid state and thus enable them to be acted upon by the various forces considered previously. Under other conditions, heat in the interior of the earth will vaporize the bitumens such as petroleum and force them upward. Again, if the heat is sufficiently intense, it is apt to cause the bitumens to undergo destructive distillation, the distillate condensing in the upper and cooler layers.

ORIGIN AND METAMORPHOSIS OF BITUMENS AND ASPHALTIC PYROBITUMENS

Probable Origin of Bitumens and Asphaltic Pyrobitumens. Although much has been written on this subject, no generally acceptable conclusions have been reached. The discussion has in the main centered about the origin of petroleum, as this is conceded to be the mother substance, from which the other bitumens and pyrobitumens are supposed to be produced by a process of metamorphosis. The theories have been divided into two classes, namely, the inorganic and the organic. We will consider these in greater detail.

Inorganic Theories. It is contended that the interior of the earth contains free alkaline metals, presumably in a melted condition. These at high temperatures would react with carbon dioxide forming acetylides which in turn produce hydrocarbons of the acetylene series upon coming in contact with water. The acetylenes being unsaturated would have a tendency to combine with free hydrogen and give rise to the olefine and paraffine series.

Still another theory based on similar lines, assumes the presence of metal carbides, including iron carbide, some distance below the surface of the earth. These are supposed to decompose on coming in contact with water and produce hydrocarbons, which upon condensing in the cooler upper strata give rise to petroleum. This, however, is mere speculation, for no iron carbide has ever been found. The occurrence of hydrocarbon gases in volcanic emanations has been cited to substantiate this theory.

The cosmical hypothesis is based upon the assumption that hydrocarbons were present in the atmosphere which originally surrounded the earth, after it had been thrown off by the sun. These hydrocarbons are claimed to have been formed by a direct combination of the elements carbon and hydrogen in the cosmic mass. As the earth cooled, the hydrocarbons condensed in the earth's crust, giving rise to deposits similar to those existing to-day. This theory has also been connected with the carbide theories, upon the assumption that at the high temperatures to

which the gases must have been subjected at the time they were thrown off by the sun, and before they condensed, the first compounds formed were carbides, silicides, nitrides, and the like. As oxidation would not commence until some time later, it is assumed that these carbides would remain locked up in the interior of the earth for geologic ages, and then gradually give rise to hydrocarbons upon being decomposed through the agency of water.

Vegetable Theories. It has long been known that certain hydrocarbons result during the decay of vegetation. The hydrocarbon methane (CH_4), otherwise known as "marsh gas" is produced in this manner, but only in comparatively small amounts. Similarly methane has been detected in the gases resulting during the decay of seaweed.

It has been shown by others that under certain conditions hydrocarbons may be produced artificially by the fermentation and decay of certain forms of cellulose, including woody fibre. Still other scientists maintain that petroleum is produced by microscopic plants known as diatoms, which occur abundantly in peat beds, and certain bogs. These organisms are found to contain minute globules of oily matter distributed in the plasma, and moreover, a waxy substance resembling ozokerite may be extracted by solvents from the diatomaceous peat. It is contended that this oil will in time and under pressure become converted into liquid petroleum, and at higher temperatures and pressures possibly into asphalt. In support of this hypothesis a bed of peat has been described near Stettin, Germany, consisting largely of diatoms and from which hydrocarbons have been extracted in quantities up to 4 per cent.

Another theory based on similar lines, infers that petroleum is derived from a slimy substance rich in organic matter known as "sapropel," composed largely of algæ, which accumulates at the bottom of stagnant waters. This slime becomes covered with sediments which through the agency time and pressure, is assumed to give rise to petroleum, and under certain conditions, to asphalt.

In a similar manner, bitumens are claimed to have been formed from deposits of vegetable matter, including various marine plants, seaweeds, etc., which accumulate at the bottom of the ocean. Just as the non-asphaltic pyrobitumens (e.g., coal) are produced by the decomposition of terrestrial vegetation, it is contended that bitumens have arisen from the decay of marine plants. This theory has a number of adherents. The optical activity of certain petroleums has been cited to substantiate the contention, since oils derived from organic matter can only possess this property. It has been proven that hydrocarbons produced from inorganic substances, such as metal carbides, do not exhibit optical activity.

Still another theory, advocating the vegetable origin of petroleum, assumes its derivation from peat, lignite or coal, which have been subjected to a sufficiently high temperature to undergo a process of destructive distillation, resulting in the production of liquid and gaseous hydrocarbons. This is supposed to have occurred at great depths below the earth's surface and the hydrocarbons condensed in upper layers.

The asphaltic pyrobituminous shales are similarly claimed to have generated petroleum under the action of heat, based on the well-known fact that when these shales are distilled commercially, petroleum-like oils are produced. It is contended that the shales themselves were derived from gelatinous algæ whose remains are still recognizable in certain of them with the aid of a microscope.

Animal Theories. In a similar manner, petroleum and asphalt are supposed to have been produced from the accumulation of animal matter at the bottom of the ocean, which in time decomposed into hydrocarbons. The presence of nitrogen in all forms of bitumen, is cited in substantiation of its production from albuminoid matter. The remains of molluscs and fish are present in certain asphaltic pyrobituminous shales, including the Albert series of New Brunswick, and in many rocks carrying petroleum and asphalt. Deposits of the latter have been reported in Galicia, Wyoming, and are particularly noticeable in the case of oil and asphalt deposits in Uvalde County, Texas, and southeastern California. In Egypt, shells are also found filled with bitumen. Others contend that the living cells are in some manner absorbed into the pores of coral reefs, and that these in time result in the formation of bituminous limestone.

Substances closely resembling petroleum and bitumens have been produced artificially by subjecting fish albumin to heat, under pressure. Animal fats have similarly been converted into hydrocarbons boiling below 300° C. (See p. 330.) The conversion of fats and albuminous substances into petroleum is said to depend upon three factors, namely, pressure, temperature and time. The variations in the composition of petroleum found in different localities, is accounted for by variations in one or more of these factors.

In conclusion it might be stated that probably all three theories embody certain elements of truth. The cosmical hypothesis is sustained by the fact that hydrocarbons have often been found in meteorites (see p. 79). The inorganic theory is borne out by the fact that hydrocarbons occur in volcanic emanations. The vegetable and animal theories in turn are supported by the presence of bitumens and pyrobitumens in rocks of sedimentary character, often carrying vegetable and animal fossil remains.

It is highly probable, therefore, that bitumens owe their origin to two or more of the theories which have been discussed, which would account for their varying chemical composition and physical characteristics.

Metamorphosis of Mineral Waxes, Asphalts, Asphaltites and Asphaltic-Pyrobitumens from Petroleum. Although there seems to be a wide difference of opinion regarding the origin of petroleum, authorities are pretty well agreed that petroleum when once formed, is gradually converted into the other types of bitumen and pyrobitumens, under the influence of time, heat and pressure. This process of transformation is known as "metamorphosis."

It is contended that mineral matter is a finely divided form, as for example "colloidal" clay, hastens this transformation by acting as a catalyzer. This theory is advanced by Clifford Richardson.¹ In studying the well-known Trinidad asphalt lake deposit, Richardson concludes that an asphaltic petroleum existing at a considerable depth is converted into a more solid form of bitumen, namely asphalt, upon being thoroughly emulsified with colloidal clay, sand and water through the medium of natural gas at a high pressure. The elements of time and temperature are equally important factors.

During the metamorphosis, hydrogen is gradually eliminated, the hydrocarbons becoming enriched in carbon, and from a chemical standpoint more complex structurally. The changes brought about during this process may be regarded as a form of polymerization, in which the hydrocarbon molecules become rearranged into more complex molecules of higher molecular weight.

The simplest hydrocarbons are present in petroleum. Those in mineral waxes are somewhat more complex, and both the structural complexity and the molecular weight increase in the case of asphalts and the asphaltic pyrobitumens. There are no sharp lines of demarcation between the various types of bitumens or asphaltic pyrobitumens. Each class gradually merges into another, and specimens will often be found on the border line, so that it is difficult to decide to which class they actually belong. (See p. 127.)

From this view-point we may regard petroleums as passing in gradual stages, under the influence of time, heat, pressure and catalyzers into the soft native asphalts, which in turn pass into harder native asphalts, then into asphaltites and finally into the asphaltic pyrobitumens and asphaltic pyrobituminous shales.²

¹ *J. Ind. Eng. Chem.*, **8**, 3, and 493; 1916, *Met. Chem. Eng.*, **16**, 3, 1917; *St. Paul (Minn.) Eng. Soc.*, May, 1917; *J. Soc. Chem. Ind.*, **37**, 59A, 1918.

² See also C. F. Mabery, "The Relations in Composition of the Different Forms of Natural Bitumens," *J. Am. Chem. Soc.*, **39**, 2015, 1917.

It is highly probable that all deposits of asphalt are produced by metamorphosis from *asphaltic* petroleum. Similarly it seems likely that all deposits of mineral wax, such as ozokerite, etc., result from the metamorphosis of *paraffinaceous* petroleum.

The transformation manifests itself from a physical standpoint by:

- (1) An increase in specific gravity.
- (2) An increase in fusing-point.
- (3) An increase in hardness.
- (4) An increase in the percentage of fixed carbon.
- (5) A decrease in the percentage of soluble in naphtha.
- (6) A decrease in the percentage of volatile matter.
- (7) An increase in the flash- and burning-points.

Although certain members are soluble in carbon disulphide, yet as the metamorphosis progresses, the solubility decreases, and this is particularly noticeable in the case of asphaltic pyrobitumens.

Elaterite, wurtzilite, albertite, impsonite and the asphaltic pyrobituminous shales represent the final stages in the metamorphosis of petroleum. The first four are comparatively free from mineral matter. If the latter predominates, the product is known as an asphaltic pyrobituminous shale. The non-mineral matter contained in these shales has the same general characteristics as elaterite, wurtzilite, albertite or impsonite, depending upon how far the metamorphosis has progressed.

In this connection it is interesting to note that on distilling non-asphaltic or mixed-base petroleum, so that the residue in the still reaches a temperature between 600 and 800° F., a form of polymerization takes place whereby asphalt-like substances are produced. In other words, the percentage of asphalt in the petroleum is *increased* under these conditions (p. 296). There is a critical temperature which favors the production of these asphalt-like bodies, known in petroleum refining as the "asphalt-forming temperature." If this temperature is increased, "cracking" takes place, in which the asphalt is destructively distilled and decomposed into simpler molecules.

The asphaltic pyrobitumens behave differently. When heated to between 600 and 800° F., they undergo "cracking." This is in reality a form of depolymerization in which complex molecules are broken down into simpler ones. As a result, the original substance, which is practically insoluble in organic solvents, increases materially in solubility. Elaterite and wurtzilite depolymerize and become completely soluble in benzol and carbon disulphide. Albertite is more difficult to depolymerize than elaterite or wurtzilite, requiring a higher temperature and an increased time of treatment. On the other hand, impsonite depolymerizes only slightly under these conditions. If heated to higher temperatures, the asphaltic pyrobitumens suffer destructive distillation, leaving a residue of coke. The depolymerization is similar to the action which takes place on melting fossil resins, such as copal, amber, etc., in manufacturing varnish.

An interesting series of tests has been made in connection with oil shales, as shown in the following table:

TABLE XIII

	SOLUBLE IN BENZOL.			
	Before Heating, Per Cent.	Temperature, Deg. C.	Duration.	After Heating, Per Cent.*
Posidonomya shale from Reutlingen.....	0.6	250	24 hrs.	0.34
		300	Additional 24 hrs.	3.24
		400	Additional 24 hrs.	0.00
				3.58
Menilite shale from Strzytki, East Galicia.....	0.85	300	½ hr.	1.21
		350	Additional hour	0.70
		350	Additional 24 hrs.	0.40
				2.31
Shale from N. S. Wales, Aust...	1.4	250	2 days	1.33
		250	Additional 8 days	0.73
				2.06
Shale from N. S. Wales, Aust...	1.4	300	2 days	28.5
		300	Additional 8 days	7.8
				36.3
Shale from N. S. Wales, Aust...	1.4	400	1 hour	4.9
		400	Additional 2 hrs.	44.9
		400	Additional 2 hrs.	5.4
		400	Additional 2 hrs.	0.0
				55.2

* Percentage calculated on the basis of the insoluble residue before heating.

The following tables will give an approximate idea of the natural metamorphosis of bitumens and pyrobitumens, one from another, likewise their behavior towards heat applied artificially.

TABLE XIV

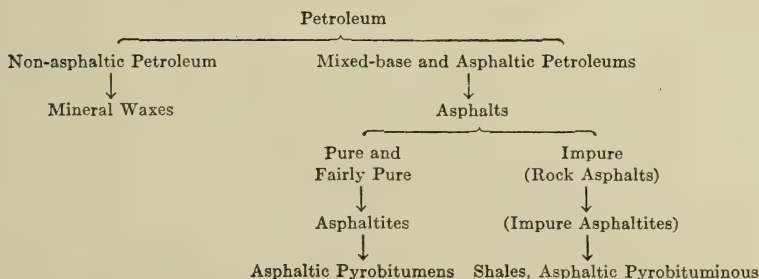

TABLE XIV—Continued

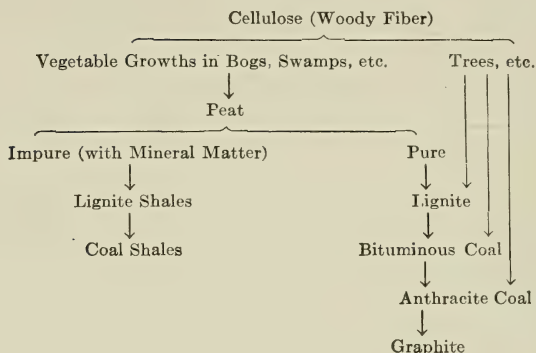

TABLE XV.—BEHAVIOR ON SUBJECTING TO HEAT

	Heated under 300° C.	Heated 300–450° C.	Heated 450–700° C.	Heated 700–1500° C.
Non-asphaltic petroleums	Distil, and the residues fuse	Residues depolymerize slightly.
Mixed base and asphaltic petroleums	Distil and the residues fuse	Residues polymerize, forming asphalt-like bodies	} Depolymerize, yielding as distillate mostly open-chain hydrocarbons and a residue of coke	}
Mineral waxes	Small amount distils with slight decomposition, and the residues fuse	Depolymerize and distil		
Asphalts and Asphaltites	Fuse	Distil more or less		
Asphaltic pyrobitumens	Infusible and insoluble	Depolymerize and become more soluble		
Non-asphaltic pyrobitumens	Infusible	Unaffected	Depolymerize slightly and distil	Depolymerize, yielding as distillate, mostly cyclic hydrocarbons and a residue of coke

ORIGIN AND METAMORPHOSIS OF NON-ASPHALTIC PYROBITUMENS

The origin of non-asphaltic pyrobitumens has been definitely established. The associated fossil remains clearly prove that these have been derived from vegetable matter containing cellulose, a carbohydrate having the empirical formula $C_6H_{10}O_5$.

The decomposition of cellulose when the air is partly or wholly excluded, as would be the case when buried in the ground, results in the loss of carbon dioxide,

methane, and water. In this manner, cellulose ultimately yields a series of products grouped under the heading of non-asphaltic pyrobitumens. The conditions favorable to their production seem to be the growth of vegetable substances about the mouths of rivers, combined with a change in water-level. The sediment carried down by the river, formed beds of sand or clay which sealed the vegetation in between the strata. In this manner the vegetable matter was protected from atmospheric oxidation and at the same time probably subjected to fermentative heat, also to a gradually increasing pressure, as successive layers accumulated. The vegetation doubtlessly embraced many different kinds, including trees, ferns, grasses, mosses, and the like. Fossil ferns are still clearly evident in coal beds. In other cases carbonized trees, roots and fibrous tissue are recognizable, and in still others, the resins originally present in the wood are found intact. Amber and fossil copal often occur in peat, and large masses of resin have been identified in beds of lignite and bituminous coal.

Peat represents the first stage in the metamorphosis of coal from vegetable matter, and occurs in bogs or other swampy places. Very often on the surface of a bog or swamp we see the still living and growing plants. A little below, we find their decayed remains, and still deeper, a black glutinous substance saturated with moisture, known as "peat."

The exact nature of the changes which take place in the transformation of vegetable matter into peat is not clearly understood. The ultimate analysis shows that the percentages of hydrogen and oxygen have diminished, and carbon correspondingly increased. In the most recent deposits, peat is loosely compacted, but as it accumulates under the sediments, it becomes compressed. A bed which was possibly once a foot thick might shrink to several inches. In all probability the pressure developed by the superimposed layers, aids in the transformation of peat into coal (see p. 198).

Lignite or browncoal is intermediate between peat and bituminous coal. The most recent deposits approach peat in composition, and the oldest merge into bituminous coal. Lignite contains a larger percentage of carbon and smaller percentages of hydrogen and oxygen than peat.

According to Clarke,¹ the lignites are grouped into six classes, viz.:

(1) True lignite, in which the ligneous structure is more or less perfectly preserved.

(2) Earthy browncoal, which has an earthy structure, and a dull lustre, often accompanied by mineral resins or wax-like hydrocarbons,² which may be extracted by means of carbon disulphide or benzol.

(3) Common browncoal, which is a compacted form of lignite.

(4) Pitch coal having a compact structure and is so named on account of its peculiar pitch-like lustre.

(5) Glance coal, which is a very hard and compact form of lignite, closely resembling bituminous coal.

¹"The Data of Geochemistry," Bulletin No. 330, U. S. Geological Survey, Wash., D. C., 1908.

²The associated resins or waxes, or asphalts, as they are termed by some, have been described under various names, including: Anthracoxenite, Bombicite, Branchite, Butyrellite, Dinite, Dopplerite, Duxite, Dysodile, Euosmite, Fichtelite, Geomyricite, Hartine, Hartite, Hofmannite, Ionite, Köllachite, Leucopetrin, Leucopetrite, Melanchyme, Mellite, Middletonite, Muckite, Neudorfite, Neft-Gil, Phytocollite, Pianzite, Pyroretin, Refkite, Retinasphaltum, Retinite, Rochlederite, Schleretinite, Sieburgite, Trinkerite, Walchowite, Wheelerite, etc.

(6) Jet, representing an extremely hard variety of lignite, claimed to have been derived from coniferous woods.

Cannel coal is in reality a subclass of bituminous coal, rich in volatile matter. It is supposed to have been derived from spores, spore cases, and resinous or waxy products of plants. The absence of woody material gives cannel coal a uniform texture and grain not present in other coals, so that it breaks with a conchoidal fracture, and a splinter ignites in contact with a lighted match, burning like a candle, whence it derives its name. G. H. Ashely¹ classifies it as follows:

(1) Subcannel coal:

- (a) Brown subcannel, of browncoal or lignite rank.
- (b) Black subcannel, of subbituminous rank.

(2) Cannel coal, of bituminous rank:

- (a) Boghead cannel (fuel ratio ² less than 0.5).
- (b) Typical cannel (fuel ratio ² between 0.5 and 1).
- (c) Lean cannel or semicannel (fuel ratio ² more than 1).

(3) Canneloid or semibituminous coal.

Bituminous coal falls between lignite and anthracite coal. It is often a matter of difficulty to determine where the lignites stop and the bituminous coals begin; similarly, the line of demarcation between bituminous and anthracite coals is not very distinct. Bituminous coals contain a larger percentage of carbon and smaller percentages of hydrogen and oxygen than lignite. The name "bituminous coal" is derived from the fact that this coal apparently softens and undergoes fusion at a temperature somewhat below that of actual combustion. The term, however, is a misnomer. The softening which takes place marks the point at which destructive distillation commences, accompanied by the formation of gaseous hydrocarbons. "Bitumen" does not actually exist in bituminous coal, which is easily proven by the fact that solvents for bitumen such as carbon disulphide have no appreciable effect upon it. Bituminous coals contain a substantial portion of volatile matter, which causes them to burn more rapidly than anthracite, and with a larger amount of flame. The so-called "coking coal" is a class of bituminous coal, used in the manufacture of coke.

Anthracite coal represents the final stage in the transformation of vegetable matter into a non-crystalline form. It contains definite proportions of hydrogen and oxygen. Certain forms of anthracite approach graphite in their composition. Graphite on the other hand is a crystallized mineral composed entirely of carbon, and which is supposed to represent the final stage in the metamorphosis of coal. The mode of occurrence and microscopic structure of graphite deposits correspond closely with those of coal, giving rise to the belief that both were derived from a common source.

The following table shows the maximum, minimum, and average percentages of carbon, hydrogen, oxygen, and nitrogen in wood, peat, lignite, bituminous coal, anthracite coal and graphite, calculated on the water-, ash-, and sulphur-free bases:

¹"Cannel Coals in the United States," U. S. Geological Survey, Bull. in preparation.

²The quotient of the fixed carbon divided by the volatile matter.

TABLE XVI

	CARBON, PER CENT.			HYDROGEN, PER CENT.			OXYGEN, PER CENT.			NITROGEN, PER CENT.		
	Min.	Max.	Aver.	Min.	Max.	Aver.	Min.	Max.	Aver.	Min.	Max.	Aver.
Wood.....	40	50	49.65	5½	7½	6.23	42	50	43.20	¼	3	0.92
Peat.....	50	65	55.44	5	7	6.28	26	44	35.56	1	3	1.72
Lignite.....	65	80	72.95	4½	6½	5.24	15	28	20.50	½	2	1.31
Bituminous Coal	80	90	84.24	4	6	5.05	3	18	8.69	½	2	1.52
Anthracite Coal.	90	95	93.50	2	5	2.81	1	5	2.72	¼	2	0.97
Graphite.....	100	...	100.00

A steady decrease in the percentages of hydrogen and oxygen thus becomes apparent, and especially if the average percentages are recalculated on the basis of 100 parts by weight of carbon, as shown in the following table:

TABLE XVII

	Carbon.	Hydrogen.	Oxygen.	Nitrogen.
Wood.....	100	12.5	87.0	1.8
Peat.....	100	11.3	64.1	3.1
Lignite.....	100	7.2	28.1	1.8
Bituminous coal.....	100	6.6	10.3	1.8
Anthracite coal.....	100	3.0	2.9	1.3
Graphite.....	100

It will be observed that the progressive decrease in the proportion of oxygen is greater than is the case with hydrogen. In cellulose $C_6H_{10}O_5$, these two elements exist in exactly the proportions required to form water (H_2O), namely 1 : 8. In wood, the hydrogen is slightly in excess of that ratio, and the excess steadily increases until in anthracite it is proportionately very large. In the former, the ratio is nearly 1 : 7, whereas in the latter it is roughly 1 : 1.

These facts are significant, and enable us to arrive at a basis for properly classifying the various non-asphaltic pyrobitumens.

CHAPTER V

ANNUAL PRODUCTION OF ASPHALTS, ASPHALTITES AND ASPHALTIC PYROBITUMENS

World Production. Deposits of natural asphalts have been discovered in all parts of the world. Table XVIII, compiled by the Department of Interior of the U. S. Geological Survey, shows the total production of all forms of native asphalts (including pure and rock asphalts), asphaltites and asphaltic pyrobitumens, from 1906 to 1916 inclusive, as far as reliable statistics are available.¹

Trinidad produces the largest quantity of native asphalt, Italy comes next, then Germany, United States and Venezuela. In the above statistics the output of petroleum asphalt is not included.

Production in United States. The annual production of native asphalts, asphaltites, asphaltic pyrobitumens, and petroleum asphalt in the United States is shown in the Table XIX.

From this it will be observed where as the production of native asphalts remained fairly constant from the years 1897 to 1916, the production of petroleum asphalt has been steadily increasing. During the last few years, the advent of petroleum asphalt manufactured from Mexican crude has become quite a factor.

The production of gilsonite and grahamite have not varied greatly during the last eight or nine years. Wurtzilite is not an important factor in the asphalt industry.

The figures in the preceding table, under the head of "Native Asphalts," comprise rock asphalts, including asphaltic sandstones and limestones, together with a small proportion of pure native asphalt. The production of the last named is relatively unimportant, and has not therefore been segregated.

The accompanying diagram (Fig. 24) shows the production of native asphalts (including rock and pure asphalts), asphaltites, asphaltic pyrobitumens and manufactured asphalts (petroleum asphalts made from domestic and Mexican crudes), together with the imports of crude asphalts into the United States from the years 1880 to 1916 inclusive.

In 1916, the production of petroleum asphalt from domestic crudes amounted to 688,334 short tons, including 404,009 tons of residual oil used either for road sprinkling or as a flux for softening harder asphalts, and 284,325 short tons of residual asphalts. These figures show a decrease of 13,800 tons in the production of road oils and fluxes, and an increase of 37,681 tons in the output of residual asphalt, as compared with 1915.

In 1916 the output of petroleum asphalts from Mexican crudes amounted to 572,387 short tons, including 295,682 tons of road oils and fluxes, and 276,705 tons

¹ "Asphalt, Related Bitumens, and Bituminous Rock in 1916," by John D. Northrup. Wash., D. C. Sept. 22, 1917.

TABLE XVIII

Year.	UNITED STATES.		TRINIDAD, ^g		GERMANY.		CUBA.	
	Quantity (short tons).	Value.	Quantity (short tons).	Value.	Quantity (short tons).	Value.	Quantity (short tons).	Value.
1906.....	73,062	\$674,934	150,373	\$832,964	129,388	\$268,631	5,717	\$26,605
1907.....	85,913	928,381	171,271	832,274	139,567	264,494	5,571	37,594
1908.....	78,565	517,485	143,552	403,023	98,088	188,334	6,875	31,574
1909.....	99,061	572,846	159,416	459,446	85,446	176,897	11,900	48,246
1910.....	98,893	854,234	157,120	421,419	89,491	152,565	2,320	13,685
1911.....	87,074	817,250	b201,284	c603,800	90,256	154,938	3,638	21,928
1912.....	95,166	865,225	b212,236	c742,800	105,950	200,743	17,260	87,500
1913.....	92,604	750,713	b257,635	c1,030,540	b1,749	30,935
1914.....	79,888	642,123	b163,076	c789,450	b969	19,491
1915.....	75,751	526,490	b152,349	736,760	b486	11,247
1916.....	98,477	923,281	b146,831	c698,475	d327	7,611

Year.	FRANCE.		ITALY.		SPAIN.		JAPAN.	
	Quantity (short tons).	Value.	Quantity (short tons).	Value.	Quantity (short tons).	Value.	Quantity (short tons).	Value.
1906.....	216,405	\$345,599	144,802	\$349,926	8,587	\$17,130	43	\$3,572
1907.....	195,136	330,065	178,127	442,014	9,057	16,001	644	5,436
1908.....	188,616	264,188	148,433	368,306	13,635	24,084	2,650	25,564
1909.....	186,298	269,161	123,361	305,159	5,822	10,282	4,614	45,205
1910.....	187,085	277,210	179,261	452,911	7,072	18,308	526	29,004
1911.....	207,926	591,550	f 4,124	8,754	1,389	13,728
1912.....	200,560	581,383	5,938	13,003	3,199	32,518
1913.....	188,601	521,398	6 153	13,402	2,491	27,242
1914.....	132,114	400,164	6,355	13,847	2,211	25,836
1915.....	52,531	184,621	4,985	10,706

Year.	AUSTRIA-HUNGARY.		RUSSIA.		VENEZUELA.		MEXICO.	
	Quantity (short tons).	Value.	Quantity (short tons).	Value.	Quantity (short tons).	Value.	Quantity (short tons).	Value.
1906.....	10,633	\$778,781	g 12,517	\$110,294	b 24,783	\$98,250	1,531	\$17,174
1907.....	11,335	727,892	g 14,116	101,705	b 42,153	167,938	4,945	182,265
1908.....	12,239	768,162	g 24,964	491,302	b 35,324	141,912	5,811	330,903
1909.....	11,179	663,246	h 2,665	4,599	b 41,767	180,061	6,031	106,484
1910.....	9,070	702,022	h 27,544	176,518	b 35,717	c 151,000	3,140	39,681
1911.....	h 8,312	652,603	b 56,183	c 238,000	8,912	125,322
1912.....	h 11,439	664,778	b 73,780	c 312,000	33,611	462,230
1913.....	b 93,884	c 400,000
1914.....	b 49,941
1915.....	b 31,949
1916.....	b 49,176

a Includes small quantity of grahamite (manjak) produced in Barbados.

b Exports. c Estimated. d Exports for six months.

e Only about 7 per cent of the quantity given represents asphalt, the remainder being bituminous sandstone and limestone.

f Figures for 1911 do not include 7,165 tons of bituminous rock for which no value was reported. Figures for 1913 do not include 5,112 tons of bituminous rock, valued at \$5,833.

g Includes pure soft native asphalts.

h Includes ozokerite.

TABLE XIX.—PRODUCTION IN THE UNITED STATES OF NATIVE ASPHALT, ASPHALTITES, ASPHALTIC PYROBITUMENS AND PETROLEUM ASPHALTS

(WEIGHT IN SHORT TONS; VALUE AT POINT SHIPMENT)

Year.	NATIVE ASPHALTS (INCLUDING ROCK AND PURE ASPHALTS).		ASPHALTITES.		ASPHALTIC PYROBITUMENS.		TOTAL PRODUCTION NATIVE ASPHALTS, ASPHALTITES AND ASPHALTIC PYROBITUMENS.		PETROLEUM ASPHALTS.			
	Quan.	Value.	Gilsonite.		Wurtzilite.		Quan.	Value.	From Domestic Crude.		Quan.	Value.
			Quan.	Value.	Quan.	Value.			Quan.	Value.		
1890	40,841	\$190,416
1891	45,054	242,264
1892	87,680	445,375
1893	47,779	372,232
1894	60,570	353,400
1895	68,163	348,281
1896	80,503	577,563
1897	76,337	675,649
1898	75,055	553,904
1899	54,389	415,958
1900	63,134	555,335
1901	84,632	461,799
1902	55,068	483,282
1903	62,167	420,701
1904	59,639	\$331,526	2,978	\$ 14,175	1,000	\$25,000	550	\$50,000	46,187	522,164
1905	49,982	177,202	10,916	47,040	1,500	37,000	500	44,000	44,405	459,135
1906	58,163	498,542	12,447	114,960	1,952	16,432	500	62,898	52,369	452,911
1907	64,240	353,346	20,285	531,965	966	7,743	422	35,327	64,997	615,406
1908	57,296	299,321	18,533	161,824	2,286	20,340	450	36,000	137,948	1,898,108
1909	66,278	307,923	28,669	218,186	3,894	32,737	220	14,000	119,817	1,540,396
1910	70,061	481,334	29,832	372,900	129,594	1,565,427
1911	51,228	285,636	30,236	486,114	5,000	15,000	610	30,500	161,187	2,225,833
1912	55,236	176,536	31,478	573,069	7,700*	61,600*	750*	37,500*	277,192	3,173,859
1913	57,549	173,764	28,000*	560,000*	6,500*	52,000*	700*	35,000*	354,344	3,755,506
1914	51,071	162,622	18,548*	335,966*	9,669	73,535	600*	27,000*	436,586	4,531,657	114,437	\$1,743,749
1915	44,329	157,083	19,909*	246,002*	10,863	94,155	650*	29,250*	360,683	3,016,969	313,787	4,131,153
1916	63,172	197,286	24,510*	539,220*	8,431	92,555	2360*	89,620*	664,503	4,715,583	388,318	3,730,436
									688,334	6,178,851	572,387	6,018,851

* Estimated.

of residual asphalt. The corresponding quantities for 1914 were 111,058 tons of road oil and flux, and 202,729 tons of residual asphalt; and for 1915, 174,854 tons of road oils and fluxes, and 213,464 tons of residual asphalt.

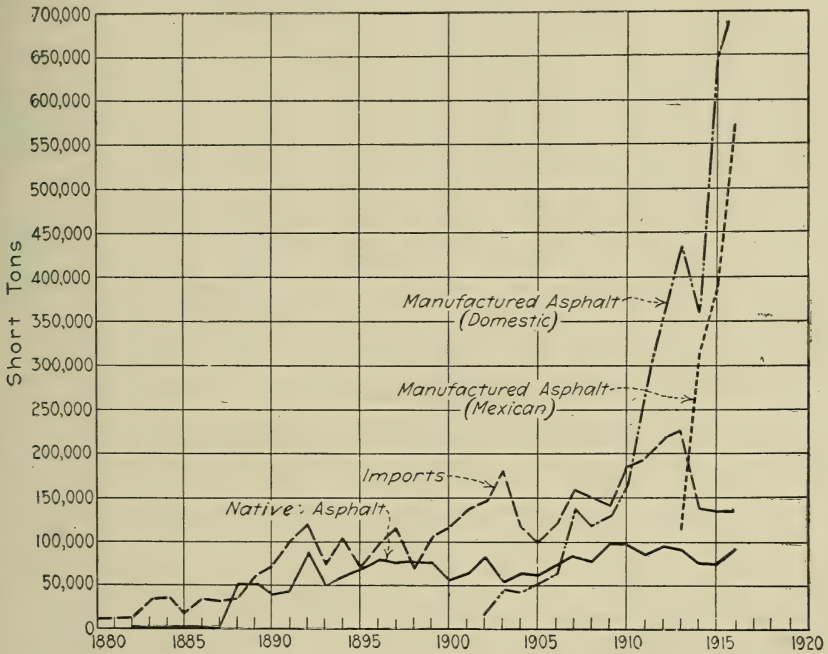

Fig. 24.—Production of Asphalts and Asphaltites in the United States from 1880 to 1916.

Production by States. The following table shows the production in short tons of native asphalts, asphaltites and asphaltic pyrobitumens in the United States during the years 1911 to 1916 inclusive, segregated according to the States in which they were produced.

TABLE XX

	1911	1912	1913	1914	1915	1916
California	36,481	36,741	27,870	28,186	17,794	18,135
Kentucky and Texas		10,145	17,465	18,935	19,311	37,777
Oklahoma	19,747 *	15,766	16,459	9,669	16,907	15,431
Utah and Colorado	30,846	32,514	30,810	23,098	21,739	27,134
	87,074	95,166	92,604	79,888	75,751	98,477

* Includes Texas and Kentucky.

The principal states producing native asphalts are California, Kentucky, Oklahoma, and Utah.

In California the native asphalts consist chiefly of bituminous sandstone from Santa Cruz and San Luis Obispo counties, together with a small quantity of bituminous limestone produced in Santa Cruz county. In Kentucky the principal native asphalts consist of bituminous sandstone mined in Edmonson and Breckinridge counties. In Oklahoma, the principal output is composed of grahamite from two localities in Pushmataha county and one in Atoka county, also bituminous sandstones produced in Pontotoc and Murray counties. The principal products of Utah include gilsonite, wurtzilite and ozokerite, together with a comparatively small quantity of bituminous sandstone. In the year 1916 there was only one deposit of native asphalt operated in the State of Texas, consisting of an asphaltic limestone near Cline, in Uvalde County.

A comparatively small quantity of asphalt-bearing shale was mined in the western part of the State of Colorado during the year 1916. This was used only for experimental work, and promises greater development.

Ozokerite deposits have been exploited in Wasatch County, Utah, and the prospects of their further development appear to be encouraging.

Imports. The asphalts imported for consumption in the United States during the years 1915 and 1916, are shown in the following table:

TABLE XXI

Imported from	1915		1916	
	Quantity (long tons)	Value.	Quantity (long tons)	Value.
Europe:				
Germany.....	658	\$4,854		
Italy.....	492	3,438		
Switzerland.....	200	1,637	295	\$1,795
England.....	774	9,801	794	8,599
North America:				
Canada.....	35	708	124	1,642
Mexico.....	56	755	22	381
West Indies:				
Barbados.....	64	6,426	123	6,279
Trinidad and Tobago.....	92,107	498,900	92,858	494,740
Other British West Indies.....			520	23,470
Cuba.....	391	9,243	524	12,701
South America:				
Venezuela.....	28,659	144,595	36,626	185,095
Oceania:				
Philippine Islands.....			1	10
	123,436	\$680,357	131,887	\$734,712
Equivalent in short tons.....	138,252		147,713	

Exports. The following statistics show the asphalts exported from the United States during the years 1912 and 1916 segregated according to the unmanufactured and manufactured varieties.

TABLE XXII

Year.	Unmanufactured.		Manufactures of (value).	Total value.
	Quantity (long tons).	Value.		
1912.....	39,915	\$886,678	\$467,959	\$1,354,637
1913.....	58,550	1,267,625	411,786	1,679,411
1914.....	37,240	845,838	401,182	1,247,020
1915.....	38,203	735,952	438,685	1,174,637
1916.....	36,443	759,769	494,895	1,254,664

Consumption of Asphalt in the United States. From the foregoing figures, it is possible to approximate the quantity of asphalts consumed in the United States, by deducting the quantity exported from the sum of the quantity marketed from domestic sources and the quantity imported. On this basis, the consumption of asphaltic materials both in the native and manufactured states in 1916 amounted to 1,456,634 short tons, as compared with 851,699 short tons in 1914, and 1,224,037 in 1915. These figures should merely be regarded as a rough approximation. Unfortunately, corresponding statistics pertaining to other countries are not available.

PART II

SEMI-SOLID AND SOLID NATIVE BITUMINOUS SUBSTANCES

CHAPTER VI

METHODS OF REFINING

Dehydration. Most native asphalts contain more or less moisture, which may be present either accidentally as hygroscopic moisture, or in the form of an emulsion. Trinidad asphalt is an example of the latter, in which about 29 per cent of water is emulsified with the asphalt and clay.

Before the asphalt can be used commercially, this water or moisture must be removed. The process by which this is accomplished is known as "dehydration." The expulsion of water is brought about by heating the asphalt in a suitable open container constructed of iron or steel, which is built in two types; viz.:

- (1) Semi-cylindrical.
- (2) Rectangular.

In either case the top is left open so that the water may be expelled readily. In modern plants, the heating tanks are built to contain between 10 and 30 tons of the crude asphalt.

The heating is effected by one of two means:

(1) By direct fire heat, in the form of a combustion chamber underneath the tank, enclosed in fire bricks. Three kinds of fuel are used for this purpose, depending upon which is most readily obtained in the locality where the asphalt is to be refined; namely, coal, oil, or gas. Coal is burnt on a grate; oil is usually sprayed into the combustion chamber by compressed air or steam; and natural or producer gas is introduced through a suitable type of burner.

In any case, the best practice consists in protecting the bottom of the melting-tank by a fire-brick arch work, so that the hot gases are compelled to circulate back and forth. This subjects the bottom of the tank to a more uniform temperature, and tends to prolong its life. At the same time, it economizes fuel by

more thoroughly extracting the heat from the hot gases, due to the increased area of contact with the bottom of the tank. In some installations, the products of combustion are caused to zigzag back and forth under the melting-tank several times, to accomplish this more effectively. Some recommend the use of a perforated brick arch to distribute the hot gases uniformly and prevent the bottom of the tank from being overheated locally.

Fire melting-tanks are usually semi-cylindrical in form, although sometimes they may be rectangular at the top, with a semi-cylindrical bottom (Fig. 25).

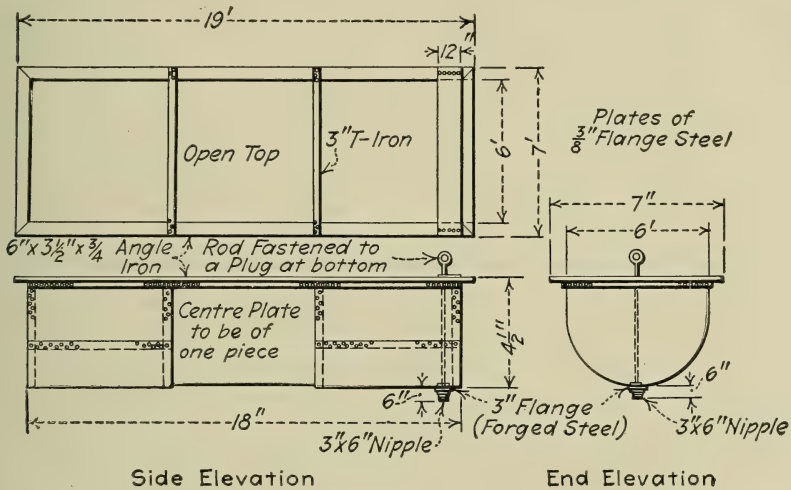

FIG. 25.—Steel Melting Tank.

(2) By means of steam. In this case the heating is effected by coils of steam pipes contained in the tank. One and one-quarter to 1 1/2-in. pipes are generally used for this purpose. According to the best practice, these are bent in coils composed of a continuous length of pipe without unions or joints. Another method consists in using cast-iron headers with straight lengths of 1 1/4 or 1 1/2-in. pipes fastened in between.

Steam is used at pressures between 125 and 150 lb. This will raise the temperature of the asphalt to 300 or 400° F. Steam has the advantage over fire heat in not coking the asphalt, which would tend to insulate the bottom, induce local overheating, and burn out the tank in a comparatively short time.

The time of heating can be reduced materially by agitating the asphalt mechanically, since the transfer of heat through a mass of asphalt is very slow. The agitation may be accomplished:

(1) By jets of dry steam which should be introduced after the temperature of the asphalt becomes sufficiently high to prevent condensation, and thus avoid excessive foaming.¹

(2) By jets of air.

(3) By mechanical agitators.

¹ U. S. Pat. 512,494 of Jan. 9, 1894, to R. D. Upham.

During the process of dehydration, the mass is apt to froth when the temperature is raised beyond the boiling-point of water. For this reason, it is well to build the tanks large enough to accommodate the foam without danger of overflowing. Shallow tanks are preferable to deep tanks.

Certain types of asphalt are most difficult to dehydrate, as they foam very badly. Numerous devices have been used to keep down the foam, the simplest and most successful consisting in directing a current of hot air against the surface of the asphalt while it is being melted.

The use of steam accelerates the evaporation of the more volatile constituents in the asphalt, and is therefore apt to cause a greater shrinkage during the dehydration than when air or mechanical mixing is used. On the other hand, air is apt to "oxidize" the asphalt and increase its fusing point, especially if its use is continued for long periods of time (see p. 350).

Any impurities such as vegetable matter, chips of wood, etc., which rise to the surface when the asphalt is melted should be skimmed off. When the asphalt is thoroughly melted and the foaming ceases, the dehydration is complete. It is usually unnecessary to raise the temperature of the asphalt higher than 350° F. The dehydrated asphalt may be discharged:

(1) By a valve at the bottom of the tank, permitting the asphalt to flow out by gravity.

(2) By a rotary pump which may either be steam-jacketed or surrounded by a steam coil in close contact with the pump, the entire installation being well insulated. The rotary pump is usually installed above the level of the asphalt, and the intake pipe extended almost to the bottom of the heating-tank.

(3) By means of a pneumatic lift installed below the bottom of the tank. The asphalt is allowed to flow by gravity into the pneumatic lift, which, by a suitable mechanism, automatically shuts off the flow when it is filled, and then admits compressed air, forcing the asphalt upward through the discharge pipe. The pneumatic lift may either be steam jacketed or heated with a steam coil as described.

Asphalt may be pumped through pipe lines for distances of 500 feet or more. To effect this it must be maintained in a melted state. This is accomplished by running a steam pipe of small diameter inside the pipe carrying the asphalt. The outer pipe should be well insulated.

Sedimentation. This process is used to separate the water where it is present in substantial quantities, as well as any coarse particles or lumps of mineral matter. It can only be used successfully with asphalts or other forms of bitumen melting below the boiling-point of water (212° F.), and not carrying the water in an emulsified state. The asphalt is maintained at a temperature not exceeding 200° F. by any of the devices described under "Dehydration," and allowed to undergo a process of "Sedimentation," whereby the entrained water and coarse mineral matter settle to the bottom, leaving the purified asphalt on top. The latter is then carefully drawn off.¹ Steam heating is most satisfactory for this purpose.

¹ U. S. Pat. 580,592 of Apr. 13, 1897, to A. F. L. Bell.

In some cases only a portion of the water separates by sedimentation, whereupon the process is supplemented by one of dehydration. The sedimentation will remove most of the water and has the advantage of materially shortening the dehydration process. A combination of the two processes will thus prove more effective than the use of either one alone.

Since water usually has a higher specific gravity than melted asphalt, it tends to settle to the bottom of the vessel containing it. This invariably proves to be the case with the softer forms of native asphalt.

Extraction. Two media have been used for this purpose, namely water and volatile solvents. As the methods are entirely different, they will be considered separately.

Extraction by Means of Water. This method has been used with more or less success for extracting asphalt from asphaltic sands, sandstone and limestone. It is based on the principle that water has a higher specific gravity than the melted asphalt, and a lower gravity than the accompanying mineral matter, so that when boiled together, the melted asphalt will rise to the surface and the mineral constituents settle to the bottom.¹

To yield successfully to this method, the rock asphalt must possess the following characteristics:

- (1) The asphalt present in the rock should have a fusing-point of not exceeding 90° F. (K. & S. method. Test 15a.)
- (2) The particles of mineral matter should be unconsolidated.
- (3) The grains of mineral matter should be fairly coarse to enable them to settle rapidly.

Experience has shown that when the fusing-point of the asphalt contained in the rock is higher than 90° F., boiling water will not effect a thorough separation.

A specimen of asphaltic sand obtained near Woodford, Okla., carrying approximately 12 per cent of asphalt and 88 per cent of sand in the form of loose, rounded grains between 40- and 80-mesh, separated fairly completely on boiling with water. The pure asphalt showed a fusing-point between 65 and 70° F. (See p. 99.)

Another asphaltic sand obtained near Fort McMurray, in northern Alberta, carrying approximately 15 per cent of asphalt and 85 per cent of non-compact sand, between 40- and 100-mesh, likewise largely separated on boiling with water. The fusing-point of the pure asphalt was 50° F. (See p. 106.)

The same was true with an asphaltic sand carrying 17 per cent of asphalt obtained from a deposit 46 miles northwest of Edmonton, and 12 miles north of Onoway. In this case the pure asphalt fused at 62° F.

A Mexican asphaltic sand carrying 16 per cent of asphalt also separated completely on boiling with water, the fusing-point of the pure asphalt being 78° F.

On the other hand, certain asphaltic sands obtained from various localities of Oklahoma, carrying between 10 and 15 per cent of asphalt refused to separate

¹ *Mines and Minerals*, Mar., 1903, "Refining Methods used by Tar Springs Asphalt Co., Tar Springs, Okla.;" *Eng. & Min. J.*, Dec. 17, 1903, "Asphalt Mining and Refining in Oklahoma," by W. R. Crane.

on boiling with water. The fusing-points of the pure asphalts were found to be 113° F., 118° F., and 127° F., respectively. The particles of the sand were substantially similar to the preceding, ranging between 40- and 100-mesh.

Plants for the water-extraction of asphalt from rock asphalt have been in operation in Oklahoma (sand asphalt); Texas (asphaltic limestone); Alberta, Canada (sand asphalt); Pechelbronn, Alsace-Lorraine (asphaltic limestone); Seyssel and Bastennes, France (asphaltic limestone); San Valentino, Italy (asphaltic limestone); and Tataros, Austria (asphaltic limestone).

According to S. C. Ells:¹

“The results when hot water and steam have been used have been most encouraging. A fairly rapid and comparatively inexpensive separation has been possible, but in actual commercial practice the extraction has not been sufficiently complete. Summarizing all evidence available to the writer, it appears that as at present understood, the use

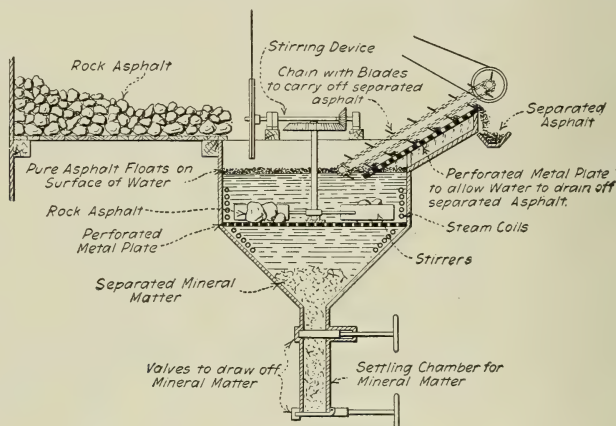

FIG. 26.—Apparatus for Separating Soft Asphalt from Sand by Means of Water.

of hot water or steam, or a combination of the two, will not give a commercial extraction of more than 60 per cent of the bitumen contained in average bituminous sand rock. In attempting to secure a higher percentage extraction, a disproportionate increase in cost will probably result.”

The machinery for extracting asphalts with water forms the subject matter of various United States Letters Patent.²

A cross-sectional diagram of an apparatus which gives fairly successful results is shown in Fig. 26. A view into the top of this extractor is shown in Fig. 27. The separated asphalt must be treated in accordance with the methods described under the heading “Dehydration,” to separate the water which is mechanically carried along with it. If the process has been performed properly, the purified asphalt will not contain more than 5 to 7 per cent of mineral matter. The water-extraction process also is used for purifying ozokerite (see p. 75).

¹“Preliminary Report on the Bituminous Sands of Northern Alberta.” Dept. of Mines, Ottawa, Canada. 1914.

²655,416, Aug. 7, 1900, to Jacob Philippi; 722,500, Mar. 10, 1903, to J. S. Downard and B. A. Roloson; 918,628, Apr. 20, 1909, to George M. Willis; 1,190,633, July 11, 1916, to C. L. Cook and J. R. Price.

Extraction with Solvents. Carbon disulphide, petroleum distillates and benzol have been used for this purpose. This method has not proven successful commercially, on account of its expense. Several plants have been constructed in the United States for extracting asphalts from asphaltic sands and sandstone. The Alcatraz Asphalt Co. of Alcatraz, Cal., erected an elaborate plant for treating rock carrying 10 to 16 per cent of asphalt. The venture, however, proved a failure through losses in solvent (a light distillate of petroleum), which made the cost of treatment prohibitive. The loss was due in part to unavoidable evaporation during

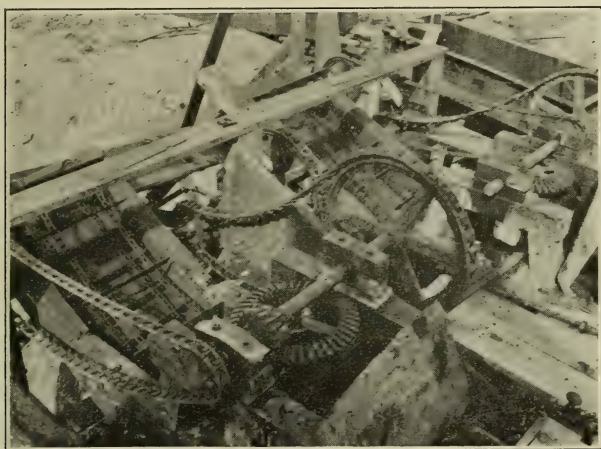

FIG. 27.—Looking into the Top of the Extracting Apparatus.

the extraction process, also to the impossibility of fully recovering the solvent from the extracted asphalt.

A number of patents have been taken out covering the use of solvents:¹

The solvent extraction process has been used successfully for recovering montan wax from lignite at Thuringia, Saxony; also from the mineral pyropissite, which is found associated with lignite at Weissenfels, near Halle, Germany. Benzol is generally used for this purpose, although in certain cases petroleum distillates have given good results.²

¹ 452,764 of May 19, 1891, to Fred Salathé; 581,546, of Apr. 27, 1897, to H. A. Frasch; 617,226 of Jan. 3, 1899, to A. S. Cooper; 617,712 of Jan. 17, 1899, to A. F. L. Bell; 655,430 of Aug. 7, 1900, to A. F. L. Bell; 1,060,010 of Apr. 29, 1913, to S. R. Murray and G. E. McDermand.

² Ger. Pats. 99,566, 101,373, 116,453, and 204,256.

CHAPTER VII

MINERAL WAXES

OZOKERITE

OZOKERITE is a native mineral wax, composed of the higher members of the C_nH_{2n+2} , and C_nH_{2n} series of hydrocarbons. It occurs in deposits usually associated with petroleum. Certain varieties carry a proportion of petroleum in solution with the wax, and the more petroleum present, the softer the consistency and lower the fusing-point. Ozokerite as ordinarily found is fairly hard, and has a comparatively high fusing-point, ranging from 150 to 180° F. The fusing-point has been recorded as high as 200° F. (K. & S. method). Ozokerite containing between 10 and 15 per cent of petroleum in solution, shows a fusing-point between 140 and 150° F. The petroleum can readily be evaporated by applying a moderate degree of heat, and is expelled during the refining process.

The color of ozokerite depends upon the nature and extent of the impurities present, and ranges from a transparent yellow to a dark brown. In rare instances, ozokerite occurs in a dichroic variety, showing a dark green color by reflected light, and a pure yellow by transmitted light. It breaks with a conchoidal fracture, and has a characteristic waxy lustre. Its streak on porcelain varies from a transparent white to a pale brown.

Ozokerite is usually found filling veins or fissures, which are very irregular in structure, varying from a fraction of an inch to about two feet in thickness. Some extend for comparatively long distances, whereas others pinch out very suddenly. The veins are usually caused by faulting, which accounts for their irregularity and gives the vein the appearance of a series of pockets. (See Fig. 21.) The indications are that the ozokerite enters the faults or veins from below, which is borne out by the fact that the material mined at a depth is materially softer and has a lower fusing-point than that obtained near the surface.

Ozokerite may occur in a pure state (comparatively free from mineral matter), which proves to be the case when it is found in vein form, or it may be associated with sandstone or shale. In fact, it is quite common for the entire region surrounding the vein to be saturated with ozokerite.

A paraffinaceous petroleum almost invariably occurs in the strata underlying the ozokerite, which would seem to indicate that the latter must have been produced by the slow hardening and probably also the oxidation of petroleum throughout centuries of time. Ozokerite, itself, however, is practically free from oxygen. In this particular case, therefore, the effect of oxidation is to eliminate hydrogen, and form hydrocarbons of higher molecular weight (see p. 575).

The petroleum underlying the ozokerite usually contains from 8 to 12 per cent of paraffine, which, however, is entirely different in its character from the hydrocarbons contained in the ozokerite. This proves conclusively that ozokerite is not formed merely by the evaporation of petroleum, but must have been produced by a process of metamorphosis or polymerization.

On distilling at atmospheric pressure, ozokerite decomposes, whereas when it is distilled under reduced pressure, its composition changes but little.

Ozokerite as it is mined is assorted by hand picking to separate the pure material from that associated with earthy matter. The latter, which is known as "wax-stone," is broken up to remove any lumps of rock and purified by extraction with water (see p. 72). The method used for this purpose is very crude, and consists merely in boiling the wax-stone with water in large open kettles. The sandstone or shale separates to the bottom and the melted ozokerite floats in a layer on the surface, whereupon it is skimmed off, boiled to evaporate the water and cast into blocks. The commercial material is comparatively free from mineral matter, rarely containing over 2 per cent.

Ozokerite may be refined still further by heating to 120–200° C., with 20 per cent by weight of concentrated sulphuric acid. This bleaches the ozokerite, forming a product almost white in color, known as "ceresine." From 10 to 15 per cent of the ozokerite is lost during the treatment, but the fusing-point of the product is increased. The final traces of acid are removed and the bleaching process completed by adding from 5 to 12 per cent of dry residue obtained from the manufacture of "ferrocyanides." The main differences between ozokerite and ceresine are in the color and fusing-point.

Ozokerite and ceresine are used in the manufacture of high-grade candles, colored lead pencils, for finishing off the heels and soles of shoes, manufacturing shoe polishes, electrical insulating purposes, and waxing floors. They are readily soluble in turpentine, petroleum distillates, carbon disulphide, and benzol, but scarcely soluble in alcohol.

Purified ozokerite and ceresine comply with the following characteristics:

(Test 1)*	Color in mass	White to yellow to brown
(Test 4)	Fracture	Conchoidal
(Test 5)	Lustre	Dull to "waxy"
(Test 6)	Streak	Transparent white to yellow
(Test 7)	Specific gravity at 77° F.	0.85–1.00
(Test 9a)	Hardness, Moh's scale	Less than 1
(Test 9b)	Penetration at 32° F.	0
	Penetration at 77° F.	20–30
	Penetration at 115° F.	150–250

* The numbers refer to tests, which are described in detail in Chapters XXVIII to XXXI.

(Test 9c)	Consistometer hardness at 32° F.	Above 100
	Consistometer hardness at 77° F.	20-40
	Consistometer hardness at 115° F.	5-15
(Test 9d)	Susceptibility factor.	Greater than 80
(Test 14a)	Behavior on melting.	Passes rapidly from a solid to a liquid state, melting to a very thin liquid of comparatively little viscosity
(Test 15a)	Fusing point (K. & S. method).	140-200° F.
(Test 19)	Fixed carbon.	$\frac{1}{2}$ -10%
(Test 21a)	Soluble in carbon disulphide.	95-100%
(Test 21b)	Non-mineral matter insoluble.	0-1%
(Test 21c)	Mineral matter.	0-5%
(Test 22)	Carbenes.	0-3%
(Test 23)	Non-mineral matter soluble in 88° petroleum naphtha.	75-95%
(Test 26)	Carbon.	84-86%
(Test 27)	Hydrogen.	16-14%
(Test 28)	Sulphur.	0-1.5%
(Test 29)	Nitrogen.	0-0.5%
(Test 30)	Oxygen.	0-2%
(Test 33)	Solid paraffine wax.	50-90%
(Test 35)	Sulphonation residue, 300-350° C. distillate.	90-100%
(Test 37)	Saponifiable constituents.	0-2%

Very often these products are adulterated with paraffine wax, rosin, tallow, stearic acid or mineral fillers (such as talc, kaolin, gypsum, etc.). These may be detected as described on page 544.

Ozokerite occurs in the following localities: ¹

Galicia. The most important ozokerite deposits are found in the Carpathian Mountains in the districts of Drohobycz (comprising Boryslaw, Wolanka and Truskawiec) and Stanislaw (comprising Dwiniacz, Straunia, Wolotkow and Niebylów). The largest deposit is located at Boryslaw, a small town in Galicia, and has been exploited since about 1859. It is found at some depths below the surface, associated with schist and sandstone, and it is mined by means of shafts and galleries. About 1500 shafts have been sunk in the district.

The following varieties of ozokerite are recognized in the Boryslaw district:

(1) Marble Wax is very hard, of a pale yellow color, with greenish, brownish and black markings, giving it the appearance of marble;

(2) Hard Wax is darker in color than Marble Wax and shows a granular fracture;

(3) Fibrous Wax is characterized by its fibrous structure;

(4) Bagga is very dark in color, and has a comparatively low fusing-point;

(5) Kindebal is characterized by being soft, of low fusing-point and a black color. It contains petroleum and mineral matter.

¹ "A Treatise on Ozokerite," by E. B. Gosling, *School of Mines Quarterly*, 16, 41, 1894; "Das Erdwachs, Ozokerite und Cerasin," by Berlinerblau, 1897; "Der Erdwachsbergbau in Boryslaw," J. Muck, 1903; "Mineral Waxes," by Rudolf Gregorius, 1905; "Das Wachs und seine technische Verwendung," Ludwig Sedna.

(6) Blower Wax (Matka) is a pale yellow variety of ozokerite which is squeezed out of the veins due to pressure of the surrounding rocks;

(7) Lep is a variety of ozokerite associated with a substantial proportion of mineral matter.

The deposit at Wolanka is smaller than that at Boryslaw. The occurrence at Truskawiec differs from the others by the presence of a comparatively large percentage of sulphur. The ozokerite in this locality is associated with native sulphur, lead sulphide, gypsum, and petroleum.

At Dwiniacz, Straunia and Wolotkow, about 70 miles south of Boryslaw, the ozokerite veins are located some distance below the surface, in beds of clay between layers of shale. Considerable ozokerite has been mined in this district, and particularly at Dwiniacz. The veins vary in size from $\frac{1}{4}$ in. to about 1 ft. The rock in the vicinity of the veins is impregnated with wax containing an average of 2 per cent.

Rumania. Deposits of ozokerite are also found in a spur of the Carpathian Mountains in the province of Moldavia in Rumania. It has been mined in several localities, the largest vein occurring in the City of Slanik, beneath a bed of bituminous shale, associated with a vein of cannel coal. This deposit is characterized by its high fusing-point, in the neighborhood of 200° F. (K. & S. method).

Russia. Small deposits occur in Transcaspian Province on the north slope of the Caucasian Mountains at Kouban, also on the Islands of Swajtoi and Cheleken in the Caspian Sea. The largest deposit in Russia occurs at the last named place accompanied by petroleum in strata of clay and chalk.¹ Minor deposits are also said to occur at Baku.

United States. The most important deposit occurs in Wasatch County, Utah, near Colton in Utah County,² in a bed of oil shale. The veins extend from about two miles west of Colton to within a few hundred yards west of the railroad station of Soldier Summit, or a total distance of twelve miles. These oil shales overlie a bed of clay in which the ozokerite occurs. A peculiar feature of this deposit is the occurrence of fossil shells together with other animal remains. The veins have been worked during 1916, about 4 tons having been mined, and part of the output refined and marketed in the form of ceresine. The following analytical results have been reported:³

(Test 1)	Color in mass.....	Yellowish brown
(Test 4)	Fracture.....	Conchoidal
(Test 5)	Lustre.....	Dull
(Test 6)	Streak.....	Pale yellow
(Test 7)	Specific gravity at 77° F.....	0.891

¹ "The Ozokerite Industry on the Island of Cheleken," *Petroleum World*, **14**, 136, 1917.

² "The Ozokerite Deposits of Soldier Summit, Utah," by W. C. Higgins, *Salt Lake Min. Rev.*, **18**, 17, 1916; "Ozokerite in Utah," L. O. Howard, *Mining Sci. Press*, **112**, 909, 1916.

³ *J. Ind. Eng. Chem.*, **5**, 973, 1913.

(Test 9a)	Hardness, Moh's scale.....	Less than 1
(Test 9b)	Penetration at 77° F.....	30
(Test 16)	Volatile, 212° F., 1 hr.....	0.0%
	Volatile, 325° F., 7 hrs.....	45.41%
	Volatile, 400° F., 7 hrs.....	65.2%
(Test 19)	Fixed carbon.....	9.6%
(Test 20)	Distillation test:	
	0-150° C.....	0.21%
	150-200° C.....	8.91
	200-250° C.....	8.38
	250-300° C.....	17.69
	300-350° C.....	25.89
	350-400° C.....	26.85
	Total volatile.....	78.93%
	Non-volatile (fixed carbon and ash).....	10.07
	Total.....	100.00%
(Test 21a)	Solubility in carbon disulphide.....	99.46%
(Test 21b)	Non-mineral matter insoluble.....	0.50%
(Test 21c)	Free mineral matter.....	0.046%
(Test 22)	Insoluble carbon tetrachloride.....	2.51%
(Test 23)	Soluble in 62° naphtha.....	81.71%
(Test 24)	Grams soluble in 100 grams of the following solvents (cold):	
	Amyl acetate.....	1
	Amyl alcohol.....	Insoluble
	Amyl nitrate.....	7
	Aniline.....	Insoluble
	Benzol.....	18
	Carbon disulphide.....	Soluble in all proportions
	Carbon tetrachloride.....	Soluble in all proportions
	Chloroform.....	Soluble in all proportions
	Ethyl acetate.....	1
	Ethyl alcohol.....	Insoluble
	Ethyl ether.....	13
	Naphtha, 62°.....	7
	Nitrobenzene.....	Insoluble
	Propyl alcohol.....	Insoluble
	Toluol.....	Very soluble
	Turpentine.....	Very soluble
(Test 26)	Carbon.....	85.35%
(Test 27)	Hydrogen.....	13.86%
(Test 28)	Sulphur.....	0.29%
(Test 29)	Nitrogen.....	0.36%

At Thrall, Texas, in the so-called Thrall Oil Field, another deposit has been reported. The crude material is soft, due to the petroleum associated with it, and of a dark brown color. It has a strong odor of petroleum, and a specific gravity at 77° F. of 0.875. On being heated to 100° C., it loses 14.72 per cent in weight, and at 180° C. a total of 23.14 per cent. On being freed from petroleum, it shows a fusing-point of 175° F.

HATCHETTITE OR HATCHETTINE

The above names are assigned to a soft variety of ozokerite fusing in the neighborhood of 120° F. (K. and S. method). It varies in specific gravity from

0.90 to 0.98 at 77° F., and has a yellowish-white, yellow or greenish-yellow color. It was named after C. Hatchett, an English chemist (1765-1847). It is found near Merthyr-Tydvil in Glamorganshire, England, also at Loch Fyne in Argyleshire, Scotland.

SCHEERERITE

A native wax found in a bed of lignite near St. Gallen, Switzerland. It occurs in the form of crystals (monoclinic) and of a white, gray, yellow, green or pale reddish color. It is more or less translucent to transparent, and has a waxy feel. It is composed chiefly of the members of the paraffine series, and fuses at a temperature of 110-115° F.

KABAITE

This is a waxy hydrocarbon similar to ozokerite or scheererite, which has been found in meteorites. It is only of scientific interest and has no commercial importance.

MONTAN WAX

As stated previously, montan wax is dissolved from certain non-asphaltic pyrobitumens by means of volatile solvents. The lignite or pyropissite is first dried, then granulated, and finally extracted. The extract is evaporated to recover most of the solvent. The last traces of solvent are expelled from the montan wax by distillation with steam, and recondensed. The crude wax differs widely according to the source, Thuringian lignites yielding a hard and brittle wax, whereas Bohemian lignites yield a softer product.

Ninety per cent of the montan wax present in the lignite is removed in this manner. About 10 to 15 per cent of the solvent is lost, but the high price obtainable for montan wax renders this permissible. Usually 8 to 10 per cent of montan wax is extracted from Thuringian lignite based on the dry weight of the latter. In exceptional cases, as high as 20 per cent has been obtained. Pyropissite yields between 50 and 70 per cent of montan wax based on its dry weight. Unfortunately, the supply of pyropissite is largely exhausted.

According to Graefe,¹ the following percentages of montan wax are extracted by benzol from the dried minerals:

Bohemian Lignite	1.29%
Texas Lignite	2.07%
Lignite from the region of the Rhine	4.70%
Lignite from Vladivostok	5.38%
Lignite from Thuringia, Saxony	9.03%
Pyropissite	69.50%

¹ "Braunkohlenteer-Industrie," Halle. 1908.

The montan wax industry is not practised in the United States, but is localized in Saxony.¹

Montan wax contains esters of acids possessing high molecular weight, free acids and a small quantity of substances containing sulphur. Various formulæ have been assigned to it, including $C_{16}H_{32}O$, $C_{29}H_{58}O_2$, $C_{29}H_{58}O_2$, and $C_{42}H_{86}O$.

At ordinary temperatures it decomposes when distilled. It may, however, be purified by distilling with superheated steam in vacuo. In this manner the following products are obtained:

- (1) Pure odorless montan acid;
- (2) Refined montan wax;
- (3) A bright yellow wax containing paraffine;
- (4) A residue containing paraffine;
- (5) An acid-free cable pitch.²

On heating with glycerine, an ester is obtained which has a much higher fusing-point (in the neighborhood of 200° F.).

Commercial montan wax complies with the following characteristics:

(Test 1)	Color in mass:	
	Crude montan wax.....	Dark brown
	Product obtained by distillation in vacuo.....	Almost white
(Test 4)	Fracture.....	Conchoidal
(Test 5)	Lustre.....	Waxy
(Test 6)	Streak on porcelain.....	Yellowish brown to white
(Test 7)	Specific gravity at 77° F.....	0.90-1.00
(Test 9c)	Hardness at 77° F. (consistometer).....	Above 100
(Test 9d)	Susceptibility factor.....	>100
(Test 10)	Ductility at 77° F.....	0.0
(Test 13)	Odor on heating.....	Pleasantly aromatic
(Test 14a)	Behavior on melting.....	Passes rapidly from the solid to liquid state
(Test 15a)	Fusing-point (K. and S. method).....	170-200° F.
	N.B.—Montan wax obtained from pyropissite has a higher fusing-point than that obtained from lignite; namely, between 190 and 200° F.	
(Test 17)	Flash point.....	550 to 575° F.
(Test 19)	Fixed carbon.....	2-10%
(Test 21a)	Solubility in carbon disulphide.....	Greater than 98%

¹ "Montan Wax, and Its Behavior on Distillation," J. Marcusson and H. Smelkus (*Chem. Zeit.* **41**, 129 and 150, 1917). According to Eisenreich montan wax shows the following figures, when tested in accordance with special methods devised by him: (*Chem. Rev. Fett-Harz-Ind.*, **16**, 211, 1909).

Saponification value.....	95
Acid value.....	93
Ester value.....	1.5
Acetyl acid value.....	93
Acetyl value.....	11
Unsaponifiable.....	29% (M.-pt. = 146° F.)
Iodine value.....	12

According to Marcusson (*Chem. Rev. Fett-Harz-Ind.*, **15**, 193, 1908) montan wax tests as follows, when examined by the usual methods applicable to fats and oils:

(Test 37a)	Acid value.....	29-33
(Test 37c)	Ester value.....	28-73
(Test 37d)	Saponification value.....	50-85

² Ger. Pat., 260,697 of Mar. 29, 1911.

(Test 21b) Non-mineral matter insoluble.....	0-2%
(Test 21c) Mineral matter.....	Less than 2%
(Test 23) Soluble in 88° naphtha.....	80-100%
(Test 24) Solubility in ether and alcohol.....	Only partly soluble
(Test 26) Carbon.....	82-83½%
(Test 27) Hydrogen.....	14-14½%
(Test 28) Sulphur.....	Less than 1.5%
(Test 29) Nitrogen.....	Trace
(Test 30) Oxygen.....	3-6%
(Test 33) Paraffine.....	0-10%
(Test 35) Sulphonation residue.....	0-10%
(Test 37) Saponifiable.....	50-80%
(Test 41) Diazo reaction.....	No.
(Test 42) Anthraquione reaction.....	No.

Montan wax is used for manufacturing shoe polishes, phonographic records, electrical insulating materials, and the like.

CHAPTER VIII

NATIVE ASPHALTS OCCURRING IN A FAIRLY PURE STATE

UNDER this heading will be considered the most important asphalt deposits containing less than 10 per cent of mineral matter figured on the dry weight. These include exudations or seepages of liquid or semi-liquid asphalts, also surface overflows and lakes. Most of these are characterized by being liquid to semi-liquid at normal atmospheric temperature, and by containing a comparatively large proportion of volatile matter. Only a few of these deposits are of value commercially.

The principal deposits are as follows:

NORTH AMERICA

UNITED STATES

Kentucky.

Breckenridge County. The so-called "Tar Springs" situated about 4 miles south of Cloverport on Tar Creek, have been known for many years. They occur as seepages of pure, soft asphalt at the base of an overhanging cliff of sandstone where it joins a stratum of limestone. The asphalt is accompanied by water charged with sulphur compounds, and the surrounding rocks abound in marine fossils.

Grayson County. Similar seepages abound along Big Clifty Creek and its tributaries, in the vicinity of Grayson Springs station. Some exude from sandstone and others from clay or shale. The seepages carry between 5 and 10 per cent of free mineral matter, the balance consisting of a very soft, "stringy" asphalt containing a large proportion of volatile ingredients and yielding about 15 per cent of fixed carbon.

Oklahoma.

There are only a few minor occurrences of pure asphalt found in the form of seepages in Oklahoma, including the following:

Carter County. NE $\frac{1}{4}$, Sec. 10, T 2 S, R 2 W; 10 miles north of Wheeler.

Murray County. SW $\frac{1}{4}$, SE $\frac{1}{4}$, Sec. 15, T 1 S, R 3 E; 3 miles south of Sulphur.

Neither of these has any commercial importance.

Utah.

Uinta County. A pure, solid asphalt is found in Tabby Canyon, a branch of the Duchesne River, 8 to 9 miles south and west of the town of Theodore and

about 30 miles west of Ft. Duchesne. It has been exploited under the name "tabbyite"¹ and tests as follows:

(Test 4)	Fracture.....	Conchoidal
(Test 5)	Lustre.....	Bright
(Test 6)	Streak.....	Black
(Test 7)	Specific gravity at 77° F.....	1.006-1.010
(Test 9a)	Hardness, Moh's scale.....	Less than 1
(Test 9b)	Penetration at 77° F.....	0
(Test 9c)	Consistency at 77° F.....	80.0
(Test 14b)	In flame.....	Softens and flows
(Test 15a)	Fusing-point (K. and S. method).....	178° F.
(Test 16)	Volatile matter, 325° F. in 7 hrs.....	2.78%
	Volatile matter, 400° F. in 7 hrs.....	6.40%
(Test 19)	Fixed carbon.....	8.08-9.2%
(Test 21a)	Soluble in carbon disulphide.....	94.7-92.1%
(Test 21b)	Non-mineral matter insoluble.....	0.5- 1.1%
(Test 21c)	Free mineral matter.....	4.8- 6.8%
(Test 22)	Carbenes.....	0.0%
(Test 23)	Soluble in 88° naphtha.....	61%
(Test 25)	Carbon.....	82%
(Test 26)	Hydrogen.....	11%
(Test 27)	Sulphur.....	2%
(Test 28)	Nitrogen.....	3%
	Undetermined.....	2%

Boxelder County. A pure viscous asphalt deposit occurs below the bed of Great Salt Lake, about 10 miles south of Rozel, in the Promintory Range² It is found in a series of horizontal veins 3 to 5 ft. thick interposed between beds of clay, continuing to a depth of at least 140 ft. It is highly probable that a lake of asphalt occurred at this point centuries ago, which in time became covered with sediments, giving rise to a series of veins.

At the present time, masses of asphalt exude through the unconsolidated material at the bottom of the lake, and rise to the surface in lumps 1 to 2 ft. in diameter. This occurrence corresponds very closely with the Dead Sea deposit (see p. 136). On analysis, the asphalt tests as follows:

(Test 4)	Fracture.....	Conchoidal
(Test 5)	Lustre.....	Very bright
(Test 6)	Streak.....	Black
(Test 9b)	Penetration at 32° F. (200 g. in 60 secs.).....	12
	Penetration at 77° F. (100 g. in 5 secs.).....	50
	Penetration at 115° F. (50 g. in 5 secs.).....	170
(Test 10a)	Ductility at 77° F.....	70 cms.
(Test 16)	Volatile at 300° F. in 24 hrs.....	2.33%
(Test 21a)	Soluble in carbon disulphide.....	95.00%
(Test 21b)	Non-mineral matter insoluble.....	1.84%
(Test 21c)	Free mineral matter.....	3.16%

California.

Kern County. The deposits of asphalt occur in the so-called "Asphalto Region" in the western part of Kern County, about 50 miles west of Bakersfield, in the form of large springs; also as veins. The character of the deposit varies greatly, both in consistency and purity. The superficial overflow covers an area of 7

¹ *J. Ind. Eng. Chem.*, 5, 973, 1913.

² "Oil and Asphalt Prospects in Salt Lake Basin, Utah," Bull, No. 260, U. S. Geol. Survey, Wash., p. 473. 1905.

acres in a layer 2 to 4 ft. thick overlying sand and clay. Part of it has hardened on account of exposure to the elements, and other portions are still soft and viscous. A vein of asphalt also occurs in the vicinity of the overflow, filling a fault, varying from 2 to 8 ft. in width, averaging about 4 ft. The nature of the asphalt in the vein is similar to that of the overflow.

The asphalt carries from 3 to 30 per cent mineral matter, mostly sand and clay, also gas, which is evidenced by the fact that it loses between 5 and 15 per cent in weight on being heated to 212° F. for one hour. The run of the mine averages 85 per cent asphalt, 10 per cent mineral matter and 5 per cent moisture and gas. It is refined by heating, which drives off the water and gas and permits a certain amount of the mineral matter to settle out. According to Richardson¹ the refined asphalt tests as follows:

(Test 4) Fracture.....	Semi-conchoidal
(Test 5) Lustre.....	Bright to dull
(Test 6) Streak.....	Black
(Test 7) Specific gravity at 77° F.....	1.06
(Test 9b) Penetration at 77° F.....	0-27
(Test 15d) Temperature at which it flows.....	180° F.
(Test 16) Volatile matter, 325° F., 7 hrs.....	6.6%
Volatile matter, 400° F., 7 hrs.....	19.9%
(Test 19) Fixed carbon.....	8.0%
(Test 21a) Soluble in carbon disulphide.....	89.8%
(Test 21b) Non-mineral matter insoluble.....	3.4%
(Test 21c) Free mineral matter.....	6.8%
Total.....	100.0%
(Test 22) Carbenes.....	0.3%
(Test 23) Soluble in 88° naphtha.....	53.4%
(Test 34) Saturated hydrocarbons.....	28.6%

The asphalt resembles gilsonite in its outward appearance, but is considerably softer, yielding a smaller percentage of fixed carbon. Richardson infers that the asphalt has been metamorphized only part way to gilsonite.

This deposit of asphalt is not being worked at the present time, but is of interest from the scientific view-point.

A sample of liquid asphalt taken from seepages in the so-called "McKittrick Region," in Kern County, shows specific gravity at 77° F., of 0.99, and 16 per cent loss on being heated to 400° F. for seven hours. In its original state it is very soft and sticky.

Santa Barbara County. Veins of high-grade asphalt occur in La Graciosa hills about 4 to 5 miles east of the town of Graciosa in the so-called Santa Maria Region. These are irregular in formation, extending through shale and sandstone, and varying from several inches to 2 ft. in width. Associated with these veins are beds of impregnated asphaltic shale, extending over an area of a mile or two, and containing a variable percentage of asphalt. One of the striking features of these occurrences is the presence of marine fossils in the veins and surrounding shale, indicating that the asphalt is of animal origin.

San Luis Obispo County. A large surface deposit of soft asphalt produced by seepage from the surrounding shale occurs at Tar Spring Creek, a tributary of the Arroyo Grande, 20 miles southeast of San Luis Obispo, covering an area of 200 ft. in diameter and 3-15 ft. deep. As it exudes from the shale the asphalt is soft and accompanied with sulphurous water; near the edge of the deposit

¹ "Modern Asphalt Pavement," loc. cit., p. 205.

it appears quite hard, and at the edge it verges towards brittleness. No analytical results are available.

Oregon.

Coos County. An unusual type of asphalt occurring in beds of coal has been reported at the Newport Mine at Libby, and Ferrey's Mine at Riverton, in the Coos Bay coal field. It is hard and brittle, and similar to coal in appearance. About one-third of the non-mineral matter is insoluble in carbon disulphide, yet the material fuses at a comparatively low temperature (about 300° F.), and has a specific gravity of less than 1.10 at 77° F. It may be regarded as a metamorphized asphalt or a glance pitch. It constitutes one of those substances encountered occasionally, falling on the border line, so that it becomes a difficult matter to arrive at its correct classification. For a long time it was known as a "Pitch Coal."¹ The following data would seem to indicate that it partakes of the properties of an asphalt rather than of a glance pitch:

(Test 4) Fracture.....	Hackly
(Test 5) Lustre.....	Fairly dull
(Test 6) Streak.....	Black
(Test 7) Specific gravity at 77° F.....	1.09
(Test 9a) Hardness, Moh's Scale.....	About 1
(Test 9b) Penetration at 77° F.....	0
(Test 9c) Consistency at 77° F.....	Above 100
(Test 14b) In flame.....	Softens and flows
(Test 15a) Fusing-point (K. and S. method).....	302° F.
(Test 19) Fixed carbon.....	10-13%
(Test 21a) Soluble in carbon disulphide.....	60.3-63.5%
(Test 21b) Non-mineral matter insoluble.....	31.5-36.5%
(Test 21c) Free mineral matter.....	2 - 8 %
(Test 23) Soluble in 88° naphtha.....	About 10%
(Test 27) Sulphur.....	0.5- 1.0%

MEXICO

State of Tamaulipas.

Asphalt springs occur at numerous points along the Tamesi River, which, according to Richardson,² show the following characteristics:

(Test 7) Specific gravity at 77° F.....	1.04- 1.12
(Test 9b) Penetration at 77° F.....	40 -16
(Test 16) Loss at 212° F. until dry.....	10 -20%
Loss at 325° F. for 7 hrs. (refined material).....	1.5 - 4.8%
Loss at 400° F. for 7 hrs.....	4.3 - 8.9%
(Test 17) Flash-point.....	308° F.
(Test 19) Fixed carbon.....	12.6-16.1%
(Test 21a) Solubility in carbon disulphide (refined material).....	89.1-99.0%
(Test 21b) Non-mineral matter insoluble.....	0.5- 1.8%
(Test 21c) Free mineral matter.....	0.5- 9.1%

Other deposits in the neighborhood show a larger proportion of mineral matter, often running as high as 33 per cent.

Chijol. Asphalt springs occur also near Chijol, 25 miles west of Tampico. They are comparatively soft in consistency, testing over 90 per cent soluble in carbon disulphide, with less than 10 per cent mineral matter.

¹ "Nineteenth Annual Report," U. S. Geol. Survey, Wash., D. C., Part III, 368, 1899.

² "Modern Asphalt Pavement," loc. cit., p. 197.

State of Vera Cruz.

Tuxpan. Similar deposits are found in the neighborhood of Tuxpan, some distance from the Tuxpan River, having the same general characteristics as the preceding. Analyses show that 90 per cent is soluble in carbon disulphide, with less than 10 per cent of mineral matter.

Chapapote. Similar deposits are found 15 miles from Timberdar at the head of the Tuxpan River, of an exceedingly pure character, testing 99 per cent soluble in carbon disulphide, and less than 1 per cent mineral matter. The asphalt varies in consistency from a semi-liquid to a comparatively hard solid, depending upon the length of time it has been exposed to the weather.

CUBA

Province of Matanzas.

A pit filled with pure liquid asphalt has been reported in the neighborhood of Santa Catalina. This occurs in a bed of serpentine, and originally produced in the neighborhood of 20 barrels of semi-liquid asphalt a day, derived presumably from underlying petroleum-bearing strata. Other pits in the neighborhood similarly yield liquid asphalt

SOUTH AMERICA

VENEZUELA

State of Bermudez

The so-called Bermudez "Pitch Lake" known as "La Felicidad" occurs on the western side of the Gulf of Paria, opposite the Island of Trinidad. The asphalt "lake" extends over 900 acres in swampy land, at the mouth of the Guanaco River, and varies in depth from 2 to 9 ft., averaging 4 ft. The surface is covered with vegetation and pools of water. A typical view is shown in Fig. 28. The lake represents the exudation of soft asphalt from springs distributed at different points over its area, and constitutes one of the largest deposits of pure asphalt yet discovered.

Its consistency varies in different parts of the lake. Where it exudes from the springs, it is quite soft, and disengages gas freely and copiously. The surface of the deposit slowly hardens on exposure to the weather, forming a crust varying from several inches to several feet in thickness, and sufficiently firm to support the weight of a man. The asphalt underneath, however, is still soft and semi-liquid, and there are numerous breaks through the surface from which the soft asphalt oozes. At the edge of the lake the asphalt is hard and brittle, due to the evaporation of the volatile constituents by the heat of the sun. Certain portions of the lake have been converted into a cokey mass as a result of fires which must have swept over the lake years ago, due probably to the combustion of vegetation growing profusely at the edges.



Courtesy of Barber Asphalt Paving Co.

FIG. 28.—View of Bermudez Asphalt Lake.

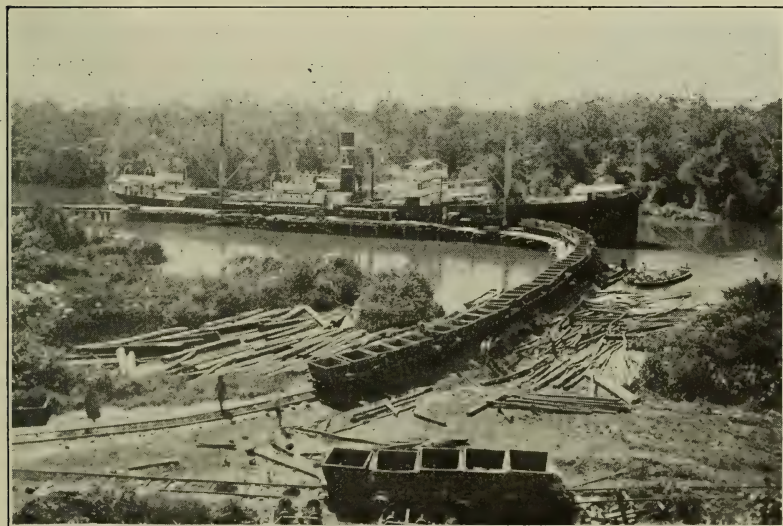

Courtesy of Barber Asphalt Paving Co.

FIG. 29.—Transporting Bermudez Asphalt.

The asphalt is gathered by hand, dumped into small cars and run to a wharf some miles distant where it is loaded on steamers, as is shown in Fig. 29.

According to Richardson¹ the dried crude Bermudez asphalt has the following composition:

(Test 1)	Color in mass.....	Black
(Test 4)	Fracture.....	Conchoidal
(Test 5)	Lustre.....	Bright
(Test 7)	Specific gravity at 77° F.....	1.005 - 1.075
(Test 15d)	Temperature at which it "flows".....	135 -188° F.
(Test 16)	Volatile at 400° F. in 7 hrs. (dried material).....	5.81-16.05%
(Test 21a)	Soluble in carbon disulphide.....	90 -98%
(Test 21b)	Non-mineral matter insoluble.....	0.62- 6.45%
(Test 21c)	Free mineral matter.....	0.50- 3.65%

The crude Bermudez asphalt is melted to drive off the moisture and gas. The water which is present is derived from the heavy rains and by overflows from the surrounding country. It is *not* emulsified with the asphalt as is the case with the Trinidad deposit. The percentage of water varies from 10 to about 40 per cent as a maximum.

Refined Bermudez asphalt tests as follows:²

(Test 4)	Fracture.....	Conchoidal
(Test 5)	Lustre.....	Very bright
(Test 6)	Streak.....	Black
(Test 7)	Specific gravity at 77° F.....	1.06-1.085
(Test 9a)	Hardness on Moh's scale.....	Less than 1
(Test 9b)	Penetration at 77° F.....	20-30
(Test 9c)	Consistency at 115° F.....	7.7
	Consistency at 77° F.....	32.7
	Consistency at 32° F.....	93.8
(Test 9d)	Susceptibility factor.....	62.5
(Test 10b)	Ductility at 115° F.....	14.5
	Ductility at 77° F.....	11
	Ductility at 32° F.....	0
(Test 11)	Tensile strength at 115° F.....	0.60
	Tensile strength at 77° F.....	3.45
	Tensile strength at 32° F.....	10.5
(Test 15a)	Fusing-point (K. and S. method).....	130 -140° F.
(Test 15d)	Temperature at which the asphalt "flows".....	170 -180° F.
(Test 16)	Volatile matter, 325° F., 7 hrs.....	3.0- 6.0%
	Volatile matter, 400° F., 7 hrs.....	8.0- 10.0%
(Test 19)	Fixed carbon.....	12.9- 14.0%
(Test 20)	Distillation test:	
	0-150° C.....	9.89%
	150-200° C.....	7.99%
	200-250° C.....	16.08%
	250-300° C.....	21.12%
	Above 300° C.....	0.0%
	Residue.....	44.92%

¹"The Modern Asphalt Pavement," loc. cit., p. 183.

²Ibid., loc. cit., p. 186; Bardwell, *J. Ind. Eng. Chem.*, **5**, 973, 1913; **6**, 865, 1914.

(Test 21a)	Solubility in carbon disulphide.....	92	- 97%
(Test 21b)	Non-mineral matter insoluble.....	1.5-	4.0%
(Test 21c)	Free mineral matter.....	1.5-	6.5%
(Test 22)	Carbenes.....	0.0-	1.0%
(Test 23)	Solubility in 88° naphtha.....	60	-75%
(Test 24)	Grams soluble in 100 grams of the following solvents (cold):		
	Amyl acetate.....	37	
	Amyl alcohol.....	Insoluble	
	Amyl nitrate.....	39	
	Aniline.....	Insoluble	
	Benzol.....	36	
	Carbon disulphide.....	In all proportions	
	Carbon tetrachloride.....	In all proportions	
	Chloroform.....	23	
	Ethyl acetate.....	24	
	Ethyl alcohol.....	Insoluble	
	Ethyl ether.....	145	
	Nitrobenzene.....	24	
	Propyl alcohol.....	Insoluble	
	Toluol.....	33	
	Turpentine.....	116	
(Test 26)	Carbon.....	82.88%	
(Test 27)	Hydrogen.....	10.79%	
(Test 28)	Sulphur.....	5.87%	
(Test 29)	Nitrogen.....	0.75%	
	Total.....	100.29%	
(Test 33)	Paraffine.....	0.0%	
(Test 34)	Saturated hydrocarbons.....	23-25%	
(Test 37d)	Saponification value.....	28.0	
(Test 38a)	Free asphaltous acids.....	3.5%	
(Test 38b)	Asphaltous anhydrides.....	2.0%	
(Test 38c)	Asphaltenes.....	35.3%	
(Test 38d)	Asphaltic resins.....	14.4%	
(Test 38e)	Oily constituents.....	39.6%	

La Brea Deposit. This also occurs as an overflow in the form of a lake, on the Island of Padernales in the delta of the Orinoco River, a comparatively short distance from the Bermudez Lake. It is about 3,200 ft. long, and an average of 200 ft. wide. Similar deposits on a smaller scale are found on the neighboring islands of Paquero and Del Plata.

State of Zulia

Maracaibo Deposit. This occurs on the Limon River located southwest of the Gulf of Maracaibo. It is also in the form of an overflow exuding from a number of springs. The asphalt is gathered by means of picks and shovels and transported in barges down the Limon River to the Gulf, where it is loaded on board steamers. It melts at a higher temperature than the Bermudez asphalt, and possesses a very strong and characteristic sulphurous odor.

According to Richardson¹ it tests as follows:

(Test 4)	Fracture.....	Conchoidal
(Test 5)	Lustre.....	Very bright
(Test 6)	Streak.....	Black
(Test 7)	Specific gravity at 77° F.....	1.06-1.08
(Test 9a)	Hardness, Moh's scale.....	Less than 1
(Test 9b)	Penetration at 77° F.....	20-30
(Test 13)	Odor on heating.....	Characteristic, strongly sulphurous
(Test 15d)	Temperature at which it flows.....	200 -250° F.
(Test 16)	Volatile at 325° F., 7 hrs.....	1.5-5%
	Volatile at 400° F., 7 hrs.....	4.7- 6.0%
(Test 19)	Fixed carbon.....	15.0- 19.0%
(Test 21a)	Solubility in carbon disulphide.....	92 - 97%
(Test 21b)	Non-mineral matter insoluble.....	1.4- 5.0%
(Test 21c)	Free mineral matter.....	1.5- 6.0%
(Test 22)	Carbenes.....	1.5%
(Test 23)	Solubility in 88° naphtha.....	45 -55%
(Test 34)	Saturated hydrocarbons.....	25 -30%

EUROPE

FRANCE

Department of Puy-de-Dôme.

In the vicinity of Clermont Ferrand, seepages of soft asphalt exude from crevices in the rock, containing 90 per cent of asphalt, 7 per cent water, and 3 per cent mineral substances. The exudations are comparatively small in amount, and the asphalt has never proved of importance commercially.

ALBANIA

Selenitza.

At the junction of the Vojutza and Sauchista Rivers, there occurs a fairly large deposit of moderately hard asphalt in sandstone and conglomerate, in veins as wide as 10 ft. Marine fossils are associated with this deposit, indicating it to be of animal origin. The asphalt breaks with a conchoidal fracture, showing a high lustre. It contains between 8 and 14 per cent of mineral matter, averaging about 10 per cent. Comparatively large quantities have been mined.

GREECE

Zante.

An extensive deposit of asphalt occurs in the southern portion of the Island of Zante, in the form of springs and seepages. The asphalt is very soft in consistency, having a specific gravity of 1.00 to 1.02 at 77° F., and carrying but a trace of mineral matter, with a fairly large proportion of water in emulsion. The springs occur in a region of clay and limestone, more or less saturated with petroleum. These deposits have been worked for many generations. (See p. 10.) The asphalt is refined in a crude way by the natives who use it for calking the seams of ships, and as a mortar for cementing together the stones of buildings, following the same method as practiced centuries ago.

¹"The Modern Asphalt Pavement," loc. cit., pp. 190-191.

ASIA

SYRIA

Deposits have been reported at Sohmor, about 30 miles south of the City of Beirut, also at Latakia in North Syria. They have never been worked to any extent.¹

EASTERN SIBERIA

Sakhalin

Province of Nutowo. An asphalt lake occurs on the east coast of the Island of Sakhalin in a swampy valley, associated with a very thick variety of petroleum, exuding in the neighborhood. Where the asphalt emanates from the springs, it is very soft and sticky, but towards the edges of the lake it is hard and brittle. The asphalt has a rather strong odor, and contains a substantial quantity of volatile matter. After being air-dried, it carries 0.75 per cent of moisture, 0.22 per cent of ash, and the balance pure asphalt containing 0.80 to 0.85 per cent sulphur. It is estimated that at least 400,000 tons of asphalt, averaging 0.9 per cent of mineral matter, are present, in the lake. Up to the present, the deposit has not been developed commercially.²

PHILIPPINE ISLANDS

Island of Leyte

Several asphalt deposits have been found in this region, one near the head of the Butason River, about 6 miles from the Barrio of Campoococ, on the north-western coast of the island, and another near the town of Villaba.³ These occur in limestone and sandstone, and extend over an area 12 miles long. Outcrops of various grades of asphalt have been reported, including the solid, viscous and liquid types. Both pure and rock asphalts are found, the latter carrying a variable proportion of sand. Two varieties of pure, hard asphalt were examined by the writer, one having a black color in mass, and a glossy, black, conchoidal fracture; another having a dark brown color in mass, with a hackly, dull fracture. They tested as follows:

	<i>Black Asphalt</i>	<i>Brown Asphalt</i>
(Test 4) Fracture.....	Conchoidal	Hackly
(Test 5) Lustre.....	Bright	Dull
(Test 6) Streak on porcelain.....	Black	Yellowish brown
(Test 9c) Consistency at 77° F.....	31.7	Greater than 100
(Test 10) Ductility at 77° F.....	$\frac{1}{2}$	0
(Test 15a) Fusing-point (K. and S. method)....	287 $\frac{1}{2}$ ° F.	138° F.
(Test 21a) Solubility in carbon disulphide.....	98%	99%
(Test 21c) Free mineral matter.....	2%	1%
(Test 37) Saponifiable matter.....	None	None

The brown variety is unique. It is somewhat similar in physical properties to montan wax, but it is very much more friable. When melted it turns black in mass, becoming lustrous (although it still shows a yellowish brown streak). The black asphalt is not classed as an asphaltite in view of its comparative softness at 77° F. These deposits have not yet been exploited commercially.

¹ "Reports from the Consuls of the U. S., 42, 228, 1893.

² *Pet. Rev. and Min. News.*, 9, [237], 230.

³ Commerce Report No. 170, p. 358, Wash., D. C., Jul. 22, 1915; also *Philippine Journal of Science*, 10A, p. 241, 1915.

CHAPTER IX

NATIVE ASPHALTS ASSOCIATED WITH MINERAL MATTER

NORTH AMERICA

UNITED STATES

Kentucky

All the deposits in the State of Kentucky are composed of sand and sandstone, carrying between 4 and 12 per cent of soft asphalt filling the interstices.¹

Carter County. This deposit occurs one-half mile southeast of the town of Soldier, and consists of unconsolidated quartz grains held together by 4 to 10 per cent of asphalt, which is comparatively soft and contains a goodly proportion of volatile matter.

Breckinridge County. This deposit is located from 2 to 4 miles south of Garfield, and is composed of unconsolidated quartz grains carrying 4 to 8 per cent of asphalt. It forms a hillside ledge about 14 ft. thick with an overburden of 10 to 20 ft. The deposit has not been worked to any great extent in recent years, although formerly it was of considerable interest in the paving industry. Other prospects occur in this neighborhood, but these have not been developed.

Grayson County. Two deposits have been worked in this locality, one 3 miles southwest, and the other 9 miles north of Leitchfield. The former occurs in a stratum 5 ft. thick, impregnated with 6 per cent of asphalt, in an unconsolidated quartz sand. The second was formerly one of the most active mines in Kentucky, but has now been idle for a number of years. It consists of a stratum 10 ft. thick, carrying 7-12 per cent of very soft asphalt. A number of seepages are in evidence along the side walls of the quarry and since the asphalt contains a large proportion volatile matter, they soon harden on exposure to the weather. Some of the seepages examined by Richardson contained 30 to 65 per cent of mineral matter, the extracted asphalt showing a penetration of between 35 and 45 at 77° F., and yielding 12 per cent of fixed carbon.

Edmonson County. Eldridge reports one deposit of asphaltic sandstone 2 miles northwest of Bee Spring, and another 1½ miles to the south. At the present time the only deposit in the State of Kentucky worked to any extent, occurs about 10 miles west of the celebrated Mammoth

¹ "Occurrences of Petroleum, Natural Gas, and Asphalt Rock in Western Kentucky," by Edward Orton, Geological Survey of Kentucky, 1891; "The Asphalt and Bituminous Rock Deposits of the United States," by George H. Eldridge, 22d Annual Report, U. S. Geol. Survey, Wash., D. C., Part I, p. 240, 1901.

Cave, near Brownsville.¹ It consists of a stratum of fine sand impregnated with 8 to 10 per cent of asphalt, occurring in irregular beds 5 to 20 ft. thick. The rock asphalt is removed from an open quarry and first run through a crusher, then through a set of rolls to disintegrate it into small grains. It is used largely for paving purposes and is said to give excellent results.

Warren County. Several deposits of sand asphalt are located at Youngs Ferry on the Green River, 12 miles north of the town of Bowling Green. One occurs in a bed about 10 ft. thick, and carries between 6 and 9 per cent of asphalt. A second consists of a vein 5 to 15 ft. thick containing about the same percentage of asphalt. Both are undeveloped. The extracted asphalt shows a penetration at 77° F. of 200, and much volatile matter (13 per cent at 400° F. in seven hours).

Logan County. A quarry has been opened up about 5 miles northeast of Russellville, exposing about 15 ft. of asphaltic sandstone in a bed about 100 ft. long. The rock carries about 7 per cent of asphalt, which shows very much less volatile matter than the preceding (about 4 per cent loss at 400° F. in seven hours). This mine is no longer active.

Missouri

Lafayette County. A bed of asphaltic sand occurs 1½ miles northwest of Higginsville, carrying 8½ per cent of asphalt, associated with sandy shale. This deposit has not been worked commercially.

Indiana

While drilling for oil at Princeton, a bed of asphalt several feet thick was found 100 ft. below a vein of coal. Seepages of liquid asphalt have also been reported in a well in the neighborhood. None of these have been developed.²

Oklahoma

This state is one of the richest asphalt-bearing centers in the United States. Asphalts are found in both the liquid and solid forms, occurring as springs, seepages and rock impregnations. Practically all the deposits are found in the southern portion of the state, between the 35th parallel of north latitude, and the Red River on the south, and included between the Arkansas line on the east, to the city of Granite, Oklahoma, on the west. This area is shown in Fig. 30, and includes deposits or prospects in the following counties:

Comanche, Jefferson, Stephens, Garvin, Carter, Murray, Love, Marshal, Johnston, Pontotoc, Atoka, McCurtain and LeFlore.

¹ M. H. Crump, *J. Royal Soc. Arts*, 59, 566, 1911.

² "Contributions to Economic Geology, 1902," Bulletin No. 213, U. S. Geol. Survey, Wash., D. C., p. 333, 1903.

The deposits consist of asphaltic sands, asphaltic limestone, mixtures of the two, and rarely asphalt impregnated shale. The principal occurrences are included in Table XXIII.¹

In the majority of cases the asphaltic impregnation is of liquid to semi-liquid consistency, having a comparatively low fusing-point. It is contended by some authorities that the vast deposits of sand asphalt previously constituted oil-sands which have been laid bare by the agencies of erosion, faulting, crumpling and upturning of the strata, so that the



FIG. 30.—Map of Asphalt Region in Oklahoma.

lighter oils and gases have escaped into the air, leaving the sand impregnated with the comparatively non-volatile asphaltic constituents. Most of the deposits occur along pronounced fault lines, although faulting is not essential, since certain deposits have become impregnated by the uprising of asphalt-bearing petroleum from regions below, through the porous sandstone or limestone.

A characteristic feature of these deposits is the sand grains which are round and unconsolidated, being held together by the asphalt filling the voids. When the asphalt is extracted the grains fall apart, and show the same general characteristics as an ordinary petroleum-bearing sand.

¹"Asphalt and Petroleum in Oklahoma," by L. L. Hutchison, Bull. 2, Okla. Geol. Survey, Guthrie, Okla., Mar. 1911.

TABLE XXIII.—ROCK ASPHALTS IN OKLAHOMA

Base.	Locality { S = Section. T = Township. R = Range.	Nearest City or Town.	Remarks.
	<i>Comanche County</i>		
	Wichita Mountain Region		
Sand	Sec. 26, T 4 N, R 11 W	3 to 4 m. W of Elgin	Exploration pit; material used for pavements of Lawton, Okla.
Sand	NE ¼, Sec. 24, T 2 N, R 11 W	6 m. NE of Lawton	Small outcrop with oil seepage. Undeveloped.
Sand	W ¼, NW ¼, Sec. 21, T 2 N, R 12 W	6 m. NW of Lawton	Low asphalt content. Along a fault. Exploited considerably.
Sand	SE ¼, Sec. 29, T 5 N, R 12 W	8 m. SW of Apache	Undeveloped deposit in the Permian Redbeds.
	<i>Jefferson County</i>		
Sand	Sec. 25, T 3 S, R 5 W	20 m. W of Wheeler	Hillside quarry in ledge 25 ft. thick. Exposed 100 yd. Extensive deposit. Used for paving. Formerly extracted by water process.
Sand	NE ¼, Sec. 33, T 3 S, R 4 W	15 m. W of Wheeler	Continuation of previous deposit. Undeveloped.
Sand	SE ¼, Sec. 6, T 1 S, R 5 W	12 m. E of Duncan	Impregnated area along a fault. Undeveloped.
Sand	SE ¼, SW ¼, Sec. 36, T 1 N, R 3 W	2½ to 3 m. W of Hennepin	Hillside quarry. Exploration pit, undeveloped. Ledge 5 to 20 ft. thick.
	<i>Garvin County</i>		
Sand	NW ¼, NE ¼, Sec. 26, T 5 N, R 1 E	5 m. SW of Ardmore	Large deposit about 30 yd. wide along fault. Exposed for about 440 yd. Extensively operated.
Sand	NW ¼, SE ¼, Sec. 14, T 5 S, R 1 E	8 m. SW of Ardmore	Large open quarry along fault. Outcrop 40 ft. by 300 ft. Vein traced about ¼ m. Contains 12-17% asphalt.
Sand	SE ¼, NW ¼, Sec. 10, T 5 S, R 1 E	6 m. SW of Ardmore	Hillside quarry in upturned area. Outcrop 20 by 50 yd.
Sand	SW ¼, NW ¼, Sec. 5, T 5 S, R 1 E	3 m. W of Waurika	Outcrop 12 by 45 ft., disappears under soil. Undeveloped.
Sand	NE ¼, NW ¼, Sec. 21, T 4 S, R 12 E	6 m. NW of Ardmore	Quarry pit about 35 ft. thick and 40 ft. deep. Two veins separated by 5 ft. of shale. Extensive deposit. Formerly extracted.
Sand	SW ¼, Sec. 19, T 3 S, R 1 E	1 m. NW of Tiff	Quarry pit in Caddo Creek bottom. 25 ft. deep. Outcrop traced about ¼ m. Extensive deposit.
Sand	Sec. 12 and N ¼ Sec. 13, T 3 S, R 2 W	18 m. NW of Ardmore	Large quarry pit about 100 ft. deep in vein 45 to 75 ft. wide. Vertical fault between shale. Water-extraction plant erected, but abandoned. Contains 12½% asphalt.

TABLE XXIII.—ROCK ASPHALTS IN OKLAHOMA—Continued

Base.	Locality { S = Section. T = Township. R = Range.	Nearest City or Town.	Remarks.
	<i>Carler County—Continued</i>		
Sand	NW ¼, Sec. 11, T 2 S, R 2 W	25 m. NW of Ardmore	Hillside quarry in ledge 30 ft. thick. Exposed for 100 yd. Water-extraction plant erected, but abandoned.
Sand	SW ¼, NW ¼, Sec. 34, T 1 S, R 2 W	10 m. NW of Woodford	Hillside quarry in ledge 10 ft. thick. Outcrop about 200 yd. along stream. Overburden 4 to 8 ft. Undeveloped.
Sand	SW ¼, Sec. 9, T 1 S, R 2 W	10 m. NW of Woodford	Ledge 8 ft. thick along creek. Outcrops for 50 yd. Overburden, 6 to 8 ft. thick. Undeveloped.
Sand	Centre of E side Sec. 21, T 3 S, R 2 W	At Wheeler	Alternate layers of shale and asphaltic sand. Percentage of asphalt decreases with depth. In centre of Wheeler oil field. Undeveloped.
Sand	NE corner Sec. 21, T 4 S, R 2 W	2 m. N. of Hewett	Outcrop reported, but undeveloped.
	<i>Murray County</i>		
	Buckhorn Region		
Sand and limestone	SE ¼, Sec. 14, T 1 S, R 3 E	9 m. NE of Dougherty	Mostly sand and trace of lime. Quarry pit in stratum 10 ft. thick. Only a moderate percentage of asphalt. Undeveloped.
Limestone	SE ¼, Sec. 23, T 1 S, R 3 E	¼ m. NW of Buckhorn	Quarry pit in fine-grained limestone carrying 14 to 15% asphalt. Fossil shells in evidence. Vein 18 in. wide and 25 to 30 ft. long. Outcrop. Undeveloped. Small and irregular percentage of asphalt.
Sand and limestone	NE ¼, Sec. 28, T 1 S, R 3 E	7 m. NE of Dougherty	Underground mine, 180 ft. deep. Vein 18 ft. by 70 ft. Contains 5-6% asphalt, also crystal calcite. Abandoned.
Limestone	S ¼, SW ¼, NE ¼, Sec. 22, T 1 S, R 3 E	7 ½ m. NE of Dougherty	Quarry pit 75 ft. by 450 ft. Carries 6-8% asphalt. Abandoned.
Sand	NE ¼, Sec. 28, T 1 S, R 3 E	7 m. NE of Dougherty	Quarry pit in stratum 8 ft. thick, carrying 7-10% asphalt. Overburden, 8-10 ft. thick of weathered asphaltic sandstone.
Sand	SW ¼, SE ¼, Sec. 15, T 1 S, R 3 E	1 m. N of Buckhorn	Pit in vein probably 25 ft. thick, carrying 7-8% asphalt. Undeveloped.
Sand	NW ¼, SE ¼, NW ¼, Sec. 22, T 1 S, R 3 E	6 m. NE of Dougherty	Three quarries, largest 100 ft. diam. in vein 8-10 ft. thick. Asphalt varies from a trace to 8-9%. Mottled appearance.
Sand and limestone	NW ¼, NW ¼, Sec. 22, T 1 S, R 3 E; also NE ¼, NE ¼, Sec. 21, T 1 S, R 3 E	6 m. NE of Dougherty	Very large quarry in stratum 15-75 ft. thick, carrying 5-13% asphalt (Pen., at 77° F., 60-65). Rock granular to crystalline (calcite)
Limestone	SW ¼, SE ¼, Sec. 21, T 1 S, R 3 E	7 m. NE of Dougherty	Continuation of previous vein. 6-12% asphalt (soft).
Sand and limestone	SE ¼, SE ¼, Sec. 21, T 1 S, R 3 E	7 m. NE of Dougherty	
Limestone	NE ¼, SE ¼, Sec. 21, T 1 S, R 3 E	7 m. NE of Dougherty	Small pit in stratum 10 ft. thick. Varies in percentage of asphalt.

TABLE XXIII.—ROCK ASPHALTS IN OKLAHOMA—Continued

Base.	Locality { S = Section. T = Township. R = Range.	Nearest City or Town.	Remarks.
Sand	<i>Murray County—Continued</i> Buckhorn Region— <i>Continued</i> SE ¼, SE ¼, Sec. 17, T 1 S, R 3 E	8 m. NE of Dougherty	Large quarry in vein 15 ft. thick, containing 10-12% asphalt. Overburden of conglomerate, 75 ft. thick. Outcrop 150 ft. (Volatile matter extracted asphalt 325° P., 7 hrs., 6 per cent.)
Sand	NE ¼ Sec. 20, and NW ¼, Sec. 21, T 1 S, R 3 E	6 m. NE of Dougherty	Small undeveloped pit with asphalt seepage in evidence.
Sand	NW ¼, NE ¼, Sec. 29, T 1 S, R 3 E	6 m. NE of Dougherty	Large deposit in stratum 38 ft. thick, containing 7-8% asphalt. Overburden, 6-8 ft. thick of gravel.
Limestone	Brunswick Region W ½ Sec. 25, and all Sec. 26, T 1 S, R 2 W	4 m. NE of Dougherty	Several quarries and pits in granular and crystalline rock, varying in percentage of asphalt. Abandoned. 3-10% asphalt.
Limestone	Washita Canyon Region Centre of Sec. 21, T 1 S, R 2 E	4 ½ m. NW of Dougherty	Prospect outcrop. Variable percentage of asphalt. Undeveloped.
Limestone	Sec. 21, T 1 S, R 2 E	4 m. NW of Dougherty	Prospect of slightly impregnated rock in shales.
Sand	Outlying Regions SW ¼ Sec. 20, and NE ¼ Sec. 29, T 1 N, R 4 E	5 m. NE of Sulphur	Outcrop containing 10-15% asphalt. Undeveloped.
Sand	<i>Love County</i> SW ¼ Sec. 6, T 6 S, R 2 E	¾ m. SE of Overbrook	Hillside quarry. Outcrop 40 yd. wide by 50 yd. long. Abandoned.
Sand	Sec. 27, T 6 S, R 2 E	N and S of Hickory Creek	Outcrop pits on top of hill. Undeveloped.
Sand	S ¾, Sec. 1, T 7 S, R 2 E	5 m. NE of Marietta	Oil springs emanating from asphaltic sand.
Sand	<i>Marsiall County</i> SW ¼, Sec. 32, T 4 S, R 5 E	2 m. W of Randolph	Low-grade asphaltic sandstone, associated with shale. Undeveloped.
Sand	SW ¼, Sec. 26, T 5 S, R 5 E	1 ½ m. NE of Madill	Outcrop 4 ft. thick. Exposed several hundred feet. Undeveloped.
Sand	NE ¼, Sec. 29, T 5 S, R 5 E	3 m. W of Madill	Sand asphalt lentil 8-10 ft. thick, carrying 4-5% asphalt.
Sand	NW ¼, Sec. 17, T 5 S, R 5 E	2 m. of Oakland	Lentil 12 ft. thick, traced 400 yd. 1-5% asphalt. Undeveloped.
Sand	NW ¼, Sec. 26, T 7 S, R 5 E	18 m. S of Madill	Small lentils about 5 ft. thick in sandstone bluff. Undeveloped.

TABLE XXIII.—ROCK ASPHALTS IN OKLAHOMA—Continued

Base.	Locality { S = Section. T = Township. R = Range.	Nearest City or Town.	Remarks.
Sand, limestone and shale	<i>Johnston County</i> NW $\frac{1}{4}$, Sec. 6, T 4 S, R 5 E; also NE $\frac{1}{4}$ Sec. 1, T 4 S, R 4 E; also S $\frac{1}{2}$, SE $\frac{1}{4}$, Sec. 36, T 3 S, R 4 E; also S $\frac{1}{2}$, SW $\frac{1}{4}$, Sec. 31, T 3 S, R 5 E	3 $\frac{1}{4}$ m. W. of Ravia	Quarry 75 by 100 ft. in stratum 6 ft. thick, with overburden of shale. Contains 2 $\frac{1}{2}$ –13% asphalt (pen., 77° F., =200), averaging about 7%. Crude material contains 65–75% soluble in HCl (limestone) and 15–20% mineral matter insoluble.
Sand Sand	<i>Pontotoc County</i> Ada Region NW $\frac{1}{4}$, NW $\frac{1}{4}$, Sec. 31, T 4 N, R 6 E NE $\frac{1}{4}$, Sec. 5, T 2 N, R 5 E	1 m. N of Randolph 5 m. N of Randolph 3 m. W of Ada 2 m. NW of Fitzhugh	Stratum 6 ft. thick, carrying 4–5% asphalt. Undeveloped. Open cut 20 by 50 ft. in stratum over 8 ft. thick. Undeveloped. Outcrop traced several miles along Sandy Creek, with numerous seepages of asphalt. Many quarries and pits. Asphalt sand with seepages of oil and asphalt. Undeveloped.
Sand Sand, limestone and shale	<i>Atoka County</i> Roff Region Sec. 15, T 2 N, R 4 E Sec. 28, and Sec. 29, T 2 N, R 6 E	2 m. NW of Roff 9 m. E of Roff	Quarry in strata 10 ft. thick. Abandoned. Several large quarries in thick stratum. Abandoned.
Shale Sand	<i>Atoka County</i> Centre Sec. 35, T 2 S, R 13 E NE $\frac{1}{4}$, Sec. 13, T 1 S, R 14 E	18 m. SE of Atoka 15 m. W of Frisco R. R.	Several prospect pits 10–15 ft. deep. Small amount of asphalt. Ledge of unknown thickness, carrying 6–8% asphalt.
Sand	<i>McCurtain County</i> Sec. 20, T 7 S, R 24 E	3 m. NE of Ada	Ledge 25 ft. thick, running $\frac{1}{2}$ m. along stream. Very large deposit containing a large percentage of asphalt. Undeveloped.
Sand	<i>LeFlore County</i> Sec. 23, T 3 N, R 26 E	1 m. E of Page	Outcrop carrying 6% asphalt. Undeveloped.

The extent of these deposits has been variously estimated from 2 to 13 million tons.¹

Most of the asphalt mined in Oklahoma has been used for paving purposes, and the author has seen many satisfactory pavements laid throughout the State which have excellently withstood the wear and tear of traffic, also exposure to the elements. It is generally necessary to modify the rock asphalts either by combining the products obtained from different deposits, or by incorporating pure sand, until a proper balance is obtained between the asphalt and the mineral constituents. In general, the best results have been obtained with mixtures containing 7 to 10 per cent of asphalt in the finished paving composition.

Numerous water extraction plants have been erected to separate the asphalt from the sand, but most of these have proven unsuccessful, since the extraction process raises the price of the refined asphalt so that it is unable to compete with petroleum asphalts obtained from other sources in the neighborhood.

Tests made with sand asphalt taken from the quarry in Carter County, Sec. 12 and N $\frac{1}{2}$ Sec. 13, T 3 S, R 2 W, 18 miles northwest of Ardmore, indicated the following. The dry sand asphalt contained 12.5 per cent of pure asphalt having a fusing-point (K. and S. method) between 65 and 69° F. On subjecting it to the water extraction process, the following results were recorded:

	Products Recovered, Per Cent.	Asphalt Content, Per Cent.	Total Pure Asphalt, Per Cent.
Asphalt recovered.....	6	95	5.7
Impure asphaltic residue.....	3	60	1.8
Separated sand waste.....	91	2½	2.3
Volatile asphalt.....	2.7
Asphalt in crude rock.....	12.5
Total.....	100

On boiling the crude rock with water, impure asphalt rises to the surface, and the "sand waste" settles to the bottom. Upon dehydrating the impure asphalt, more sand settles out, constituting what is designated "Impure Asphaltic Residue." The pure asphalt drawn off from this residue is termed "Asphalt Recovered."

The "Asphalt Recovered" contained 5 per cent of mineral matter and tested as follows:

(Test 9c) Consistency at 32° F.....	10.0
Consistency at 77° F.....	1.5
Consistency at 115° F.....	0.0
(Test 9d) Susceptibility factor.....	15
(Test 15a) Fusing-point (K. and S. method).....	65-69° F.
(Test 16) Volatile at 500° F. in 4 hrs.....	10%

¹"Rock Asphalts of Oklahoma and Their Use in Paving," by L. C. Snider, *Petroleum*, 9, 974, 1914.

Examination of Residue (from Test 16)

(Test 9c) Consistency at 32° F.....	72.6
Consistency at 77° F.....	10.7
Consistency at 115° F.....	1.1
(Test 9d) Susceptibility factor.....	63.1
(Test 10b) Ductility at 77° F.....	Over 100
(Test 15a) Fusing point (K. and S. method).....	115° F.

Upon evaporating the "Asphalt Recovered" at 250–260° C., the following figures were recorded:

Total Loss, Per Cent.	Fusing-point.	Hardness at 77° F.
15	120	14.0
20	125	25.0
25	147	36.3
27	165	51.3

A sample of the "Asphalt Recovered" upon being blown with dry air at 300° C. for nine hours, lost 23 per cent in weight, showed a fusing-point of 165° F., and a hardness at 77° F. of 48.0. It is apparent that the extracted asphalt is scarcely affected by blowing, and thus differs from asphalts obtained upon distilling petroleum. This is further corroborated by the author's observations on paints made from the extracted sand asphalt, which were found to be *highly resistant* to atmospheric oxidation. A sample spread on cloth and exposed to air indoors for about a year, showed scarcely any diminution in tackiness. Petroleum asphalts of the same consistency when tested in a similar manner, dry out in a much shorter time.

A mixture containing 82 per cent of the "Asphalt Recovered" fluxed with 18 per cent of grahamite, showing the same fusing-point (165° F.), tested as follows:

(Test 7) Specific gravity at 77° F.....	1.09
(Test 9c) Consistency at 115° F.....	14.7
Consistency at 77° F.....	27.1
Consistency at 32° F.....	65.4
(Test 9d) Susceptibility factor.....	30.7
(Test 10b) Ductility at 115° F.....	4.5
Ductility at 77° F.....	1.0
Ductility at 32° F.....	0.0
(Test 11) Tensile strength at 115° F.....	1.8
Tensile strength at 77° F.....	6.5
Tensile strength at 32° F.....	9.5
(Test 15a) Fusing-point (K. and S. method).....	165° F.
(Test 16) Volatile at 500° F. in 4 hrs.....	0.5%

Louisiana.

Lafayette Parish. A sand asphalt deposit has recently attracted attention about 5 miles from Lafayette, covering about 50 acres on the surface.¹

Texas.

Montague County. Deposits are reported 3 to 3½ miles northeast of the City of St. Jo, carrying between 5 and 11 per cent of asphalt, averaging in the neighborhood of 7 per cent, although the percentage varies in different localities. They

¹ Manufacturers Rec., 71, 64, 1917.

contain sandstone, or a mixture of sandstone and limestone, but are of no commercial importance.

Burnet County. This occurrence is at Post Mountain near the town of Burnet, and consists of an asphaltic limestone, containing about 10 per cent of asphalt, of a very soft consistency (having a penetration of 20-250 at 77° F.).

Uvalde County. The most important Texan deposits are found in the southwestern part of this county, about 18 to 25 miles west of the city of Uvalde, in the region of the Anacacho Mountains. They consist of limestone, carrying 10 to 20 per cent of asphalt, averaging about 15 per cent. Crystalline calcite is present, also numerous fossil remains of molluscs, indicating the asphalt to be of animal origin. The deposits have been traced for several miles, but their exact extent is not accurately known. A large quantity has been quarried, and from recent reports the deposit is still being operated. The impregnating asphalt is quite hard, showing a conchoidal fracture and brilliant lustre. It has a moderately high fusing-point, and analyzes: carbon 81 per cent, hydrogen 12 per cent, sulphur 6½ per cent, nitrogen ½ per cent; total 100 per cent.

Other deposits of the same general character are found in the neighborhood. One 20 miles south-southwest of Uvalde and 5 miles south of the preceding quarry showed 12 per cent of asphalt with 17 per cent of fixed carbon.

Anderson, Jasper, and Cooke Counties. Minor deposits are reported in these counties, but are of no commercial value.¹

Utah.

Carbon County. A deposit of asphaltic limestone occurs at the head of the right-hand branch of Pie Fork, a canyon northwest of the town of Clear Creek. The rock is non-uniform in composition, some containing between 6 and 14 per cent of asphalt (having a penetration at 77° F. of 7 to 15), and some as high as 75 per cent (showing a penetration of 45 at 77° F.) with scarcely any fixed carbon.

Utah County. A large area underlaid with asphaltic limestone occurs just north of Colton, and south of Strawberry Creek, extending from Antelope Creek on the east to Thistle on the west. The principal deposit is at the town of Asphalt. No analyses are available.

Grand County. At the head of the West Water Canyon about 20 miles north of the town of West Water, there is an asphaltic limestone deposit containing 50 per cent asphalt and 50 per cent limestone. Investigations indicate that this asphalt is a progenitor of gilsonite. The extracted asphalt is reported by Richardson to test as follows:

(Test 7) Specific gravity at 77° F.....	1.037
(Test 9b) Penetration at 77° F.....	22
(Test 16) Volatile at 212° F, 1 hr.....	2.8%
(Test 19) Fixed carbon.....	8.0%
(Test 23) Soluble in 88° naphtha.....	88.7%

Uinta County. The largest deposit of asphaltic sandstone occurs southeast of Vernal, north of the White River, between the Ashley and Uinta Valleys, in a vein 3 to 16 ft. wide.² It contains in the neighborhood of 11½ per cent asphalt.

Another deposit, or rather a series of deposits, occurs in Argyle Creek, a trib-

¹"A Contribution to the Chemistry of Some of the Asphalt Rocks Found in Texas," by H. W. Harper; University of Texas Mineral Survey No. 2, May, 1902.

²Wigglesworth, *Trans. Am. Inst. Mining Eng.*, 17, 115, 1888.

utary of the Minnie Maud Creek, which in turn flows into the Green River about 20 miles south of Ouray. The material consists of an asphaltic sandstone, exploited under the name "Argulite," carrying between 8 and 10 per cent of asphalt. The extracted asphalt tests as follows:

(Test 5)	Lustre.....	Bright
(Test 6)	Streak.....	Black
(Test 7)	Specific gravity at 77° F.....	0.997-1.013
(Test 9b)	Penetration at 77° F.....	14°
(Test 15d)	Temperature at which it flows.....	140° F.
(Test 16)	Volatile at 325° F. in 7 hrs.....	25.8%
(Test 19)	Fixed carbon.....	8.55%
(Test 23)	Soluble in 88° naphtha.....	88%
(Test 26)	Carbon.....	89.9%
(Test 27)	Hydrogen.....	9.0%
(Test 28)	Sulphur.....	0.0%
(Tests 29 and 30)	Nitrogen and oxygen.....	1.1%
	Total.....	100.0%
(Test 34)	Saturated hydrocarbons.....	25.0%

Utah County. A sand asphalt deposit occurs about 1½ miles from Thistle, carrying 12 per cent of asphalt. This has been operated to but a small extent.

Carbon County. Deposits of bituminous sand have been reported 8 miles from Sunnyside on the tributaries of Whitmore Canyon, carrying 11 per cent of very soft asphalt. The extracted asphalt tests as follows:

(Test 16)	Volatile at 325° F., 7 hrs.....	6.6%
(Test 19)	Fixed carbon.....	5.0%
(Test 23)	Soluble in 88° naphtha.....	91.8%

California

Mendocino County. Deposits of asphaltic sand are found 2 miles north of the town of Point Arena and ½ mile from the coast, carrying between 6 and 7 per cent of asphalt. A similar deposit occurs just north of Port Gulch.

Santa Cruz County. Large deposits of asphalt sand occur 4 to 6 miles northwest of the city of Santa Cruz, near the summit of Empire Ridge, a spur of the Santa Cruz Mountains, 3½ miles from the coast. A number of quarries have been opened up in this region, and the product used for constructing pavements in Santa Cruz and San Francisco. The rock contains between 10 and 17½ per cent of a very soft asphalt with a substantial proportion of volatile matter. The veins vary from 2 to 30 ft. in thickness, as shown in Figs. 31 and 32.

Monterey County. Several deposits of asphaltic sandstone are scattered throughout the Salinas Valley. A prospect occurs about 10 miles from King City, composed of particles of quartz, feldspar and mica, impregnated with a varying percentage of asphalt. Another deposit occurs 7 miles southeast of Metz at the head of Chelone Creek, of the same general character. A large vein, about 125 ft. thick and 3 miles long, has been reported near San Ardo, composed of coarse quartz grains, and a little feldspar, impregnated with a small percentage of asphalt.

San Luis Obispo County. Sand asphalt deposits occur about 80 miles southwest of the town of San Luis Obispo, consisting of a number of actively worked quarries. The rock is fine grained, of even texture, consisting mostly of quartz, with a small quantity of feldspar. The percentage of asphalt varies from 8 to 18 per cent, averaging about 10.

Santa Barbara County. Santa Maria Region. Associated with the pure asphalt deposit described on page 84, zones of asphalt-impregnated shale have been reported on the western slope of the Azufre Hills, containing 30 to 40 per cent of asphalt.

Sisquoc Region. Deposits of sand asphalt occur in the neighborhood of the town of Sisquoc, carrying between 14 and 18 per cent of asphalt. The largest vein occurs in Bishop's Gulch, about 100 ft. thick, running fairly uniform in com-

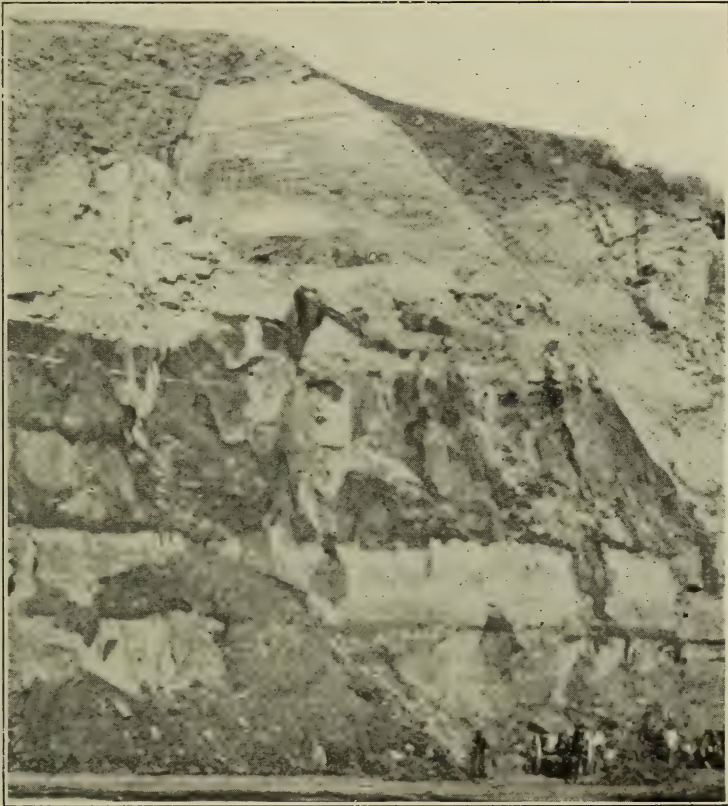

FIG. 31.—Sand Asphalt Quarries in Santa Cruz County, Cal.

position. Some time ago an attempt was made to remove the asphalt by extraction with solvents, but the process proved too costly and had to be abandoned. Similar deposits are found in the neighborhood of La Brea Creek, where a vein of sand asphalt occurs 20 to 60 ft. thick; also at Los Alamos Creek.

Gaviota Region. A prospect has been reported in this locality consisting of a bed of sandstone and conglomerate about 25 ft. thick, containing 7 to 8 per cent of asphalt.

Mores' Landing. This deposit is found on the seacoast about 7 miles west of Santa Barbara, occurring as veins and irregular masses in massive sandstone cliffs,

at least 100 ft. thick. According to Eldridge it contains 30 to 60 per cent of asphalt and has a strong resemblance in structure, brilliancy, and fracture to gilsonite, although it is very much softer in consistency.

La Patera Region. A vein of asphalt of historical interest only, occurs about 10 miles west of Santa Barbara, close to the coast. It varies in width from 2 to 12 ft., with a number of lateral branches several inches thick. The asphalt is associated with 30 to 50 per cent of mineral matter composed of shale, sand, and

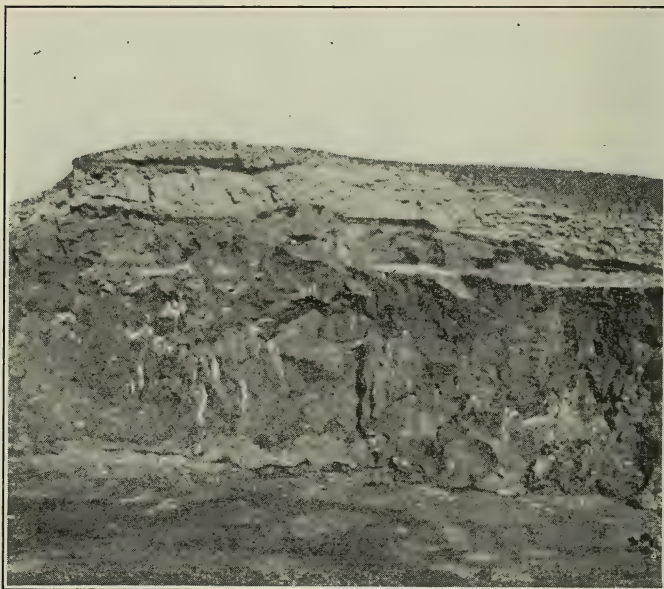

FIG. 32.—Sand Asphalt Quarries in Santa Cruz County, Cal.

clay. It is stated that 30,000 tons have been removed from this mine, testing, when dried, as follows:¹

(Test 4) Fracture.....	Irregular
(Test 5) Lustre.....	Dull
(Test 6) Streak.....	Black
(Test 7) Specific gravity at 77° F.....	1.38
(Test 9a) Hardness on Moh's scale.....	2
(Test 9b) Penetration at 77° F.....	0
(Test 15d) Temperature at which it flows.....	300° F.
(Test 16) Volatile at 400° F., 7 hrs.....	2.5%
(Test 19) Fixed carbon.....	14.9%
(Test 21a) Soluble in carbon disulphide.....	Approx. 50%
(Test 21c) Free mineral matter.....	About 50%
(Test 23) Soluble in 88° naphtha.....	21.6%
(Test 28) Sulphur.....	6.2%
(Test 34) Saturated hydrocarbons.....	8.1%

¹ "The Modern Asphalt Pavement," loc. cit., p. 201.

Carpinteria Region. This deposit composed of asphaltic sand about 15 ft., thick, lying along the ocean's shore, is illustrated in Fig. 33. It contains 18 to 20 per cent of asphalt filling the interstices of unconsolidated quartz grains. Some time ago a process was installed for extracting the asphalt with water, but this never proved successful commercially.

Orange County. Bituminous sands have been reported 4 miles southwest of Chino, in a layer about 6 ft. thick, containing varying percentages of asphalt.

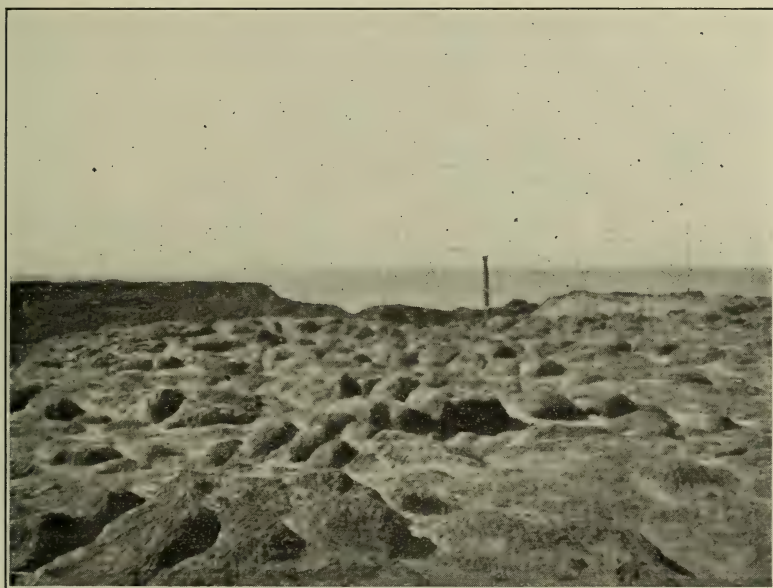

FIG. 33.—Asphaltic Sand on the Shore at Carpinteria, Cal.

CANADA

Alberta

McMurray Region. Vast deposits of asphaltic sands occur on both banks of the Athabaska River, and its tributary, the Clear Water River, covering probably not less than 750 square miles.¹ A characteristic view of the outcrop on the Athabaska River is shown in Fig. 34 (A and B).

These sands contain about 19 per cent of asphalt, which is amenable to the water-extraction process. A specimen of the extracted asphalt examined by the author tested as follows:

(Test 7)	Specific gravity at 77° F.....	1.022
(Test 9b)	Penetration at 77° F.....	Too soft for test
(Test 9c)	Consistometer hardness at 115° F.....	0.0
	Consistometer hardness at 77° F.....	0.0
	Consistometer hardness at 32° F.....	2.7

¹"Bituminous Sands of Northern Alberta," by S. C. Ells, Dept. of Mines, Ottawa, Canada, 1914.

(Test 10b) Ductility at 115° F.	2.0
Ductility at 77° F.	7.0
Ductility at 32° F.	12.5
(Test 15a) Fusing-point (K. and S. method)	50° F.
(Test 16) Volatile at 500° F. in 4 hrs.	17.9%
(Test 19) Fixed carbon	10.55%
(Test 21a) Soluble in carbon disulphide	97.3%
(Test 21c) Free mineral matter	2.7%



(A)

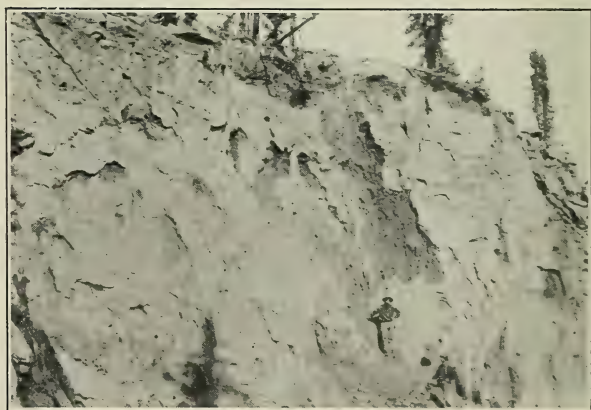

(B)

Courtesy of S. C. Ellis.

FIG. 34.—Asphaltic Sand on Banks of Athabaska River, Alberta, Can.

The non-volatile matter tested as follows:

(Test 7) Specific gravity at 77° F.	1.028
(Test 9b) Penetration at 77° F.	52
(Test 9c) Consistency at 115° F.	3.7
Consistency at 77° F.	8.5
Consistency at 32° F.	49.3

(Test 9d)	Susceptibility factor.....	36.5
(Test 10b)	Ductility at 115° F.....	34.5
	Ductility at 77° F.....	45.0
	Ductility at 32° F.....	0.5
(Test 11)	Tensile strength at 115° F.....	0.3
	Tensile strength at 77° F.....	1.5
	Tensile strength at 32° F.....	25.5
(Test 15a)	Fusing-temperature (K. and S. method).....	125° F.
(Test 19)	Fixed carbon.....	12.33%

The crude asphalt, after being tempered with additional pure sand to reduce the percentage of asphalt, has given successful results for paving purposes in Edmonton, Canada.

MEXICO

Several deposits of sand asphalt have been reported in the neighborhood of Tampico and Vera Cruz, containing 8 to 14 per cent of asphalt, but none have been developed commercially.

CUBA

Province of Matanzas. Semi-solid asphalts have been mined for many years at the bottom of Cardenas Harbor. The most important deposit, known as the Constancia Mine, occurs about 12 ft. below the level of the water, and is consequently mined with difficulty. Other deposits of semi-liquid asphalt containing more or less mineral matter, occur at the mouth of the La Palma River, about 20 miles from Cardenas; also near Sabanillo de la Palma, about 30 miles east of Cardenas and 4 to 5 miles west of Hato Nuevo. Analyses are not available.

Province of Pinar del Rio. Deposits of sand asphalt have been reported at Bahia Honda and Mariel, in the neighborhood of Mariel Bay, also at Vuelta Abajo. No analyses are available.

Province of Havana. An extensive deposit known as the "Angelo Elmira Mine," has been found near Bejucal, about 18 miles south of Havana, associated with mineral matter composed of calcium carbonate, silica, and silicates, which, according to Richardson,¹ tests as follows:

(Test 1)	Color in mass.....	Black
(Test 4)	Fracture.....	Semi-conchoidal
(Test 5)	Lustre.....	Dull
(Test 6)	Streak.....	Reddish brown to brown
(Test 7)	Specific gravity at 77° F.....	1.30-1.35
(Test 9a)	Hardness, Moh's scale.....	2
(Test 9b)	Hardness, penetrometer at 77° F.....	0
(Test 15d)	Temperature at which it flows.....	240-270° F.
(Test 16)	Volatile at 325° F., 7 hrs. (dry substance).....	About 1%
	Volatile at 400° F., 7 hrs. (dry substance).....	About 1½%
(Test 19)	Fixed carbon.....	17.4-25.0%
(Test 21a)	Soluble in carbon disulphide.....	70 -75%
(Test 21c)	Free mineral matter (calcium carbonate, etc.).....	21 -28%
(Test 23)	Soluble in 88° naphtha.....	32 -50%
(Test 28)	Sulphur.....	About 8.3%

Province of Camaguey. Impure soft and hard asphalt deposits are found near Minas, a small town between Camaguey and Nuevitas.

¹ "The Modern Asphalt Pavement," loc. cit., p. 195.

SOUTH AMERICA

TRINIDAD

St. Patrick County.

One of the largest deposits of asphalt in the entire world occurs on the Island of Trinidad¹ on the north coast of South America, situated a short distance from the mainland of Venezuela, between the Caribbean Sea on the west and the Atlantic Ocean on the east.

Small deposits are scattered all over the Island, but the largest one known as the "Trinidad Asphalt Lake," is situated on La Brea Point, in the Wards of La Brea and Guapo, on the western shore. The lake is situated on the highest part of La Brea Point, 138 ft. above sea level. It covers an area nearly circular comprising 115 acres, in a slight depression or shallow crater at the crest of the hill. The exact location of the lake is shown in Fig. 35. The lake measures about 2000 ft. across and over 135 ft. deep in the centre, becoming shallower towards the edges. A panoramic view is shown in Fig. 36.

The asphalt surface is broken up into a series of large folds with accumulations of rain water in the creases. A typical view is shown in Fig. 37. The entire mass of asphalt is in constant but slow motion from the centre towards the edges, probably due to the continual influx of solid material at the centre, accompanied by a strong evolution of gas which imparts a porous or honeycombed structure. The evolution of gas through the water is shown in Fig. 38. Wherever a hole is dug in the surface, it slowly fills up and disappears. The asphalt is softest in the centre of the deposit, and gradually hardens towards the circumference. Even in the centre, the consistency is such that it will bear the weight of a man, and can be readily broken out in large masses with picks as shown in Fig. 39.

Shrubs and small trees grow on the surface in isolated patches known as "islands," which slowly migrate from place to place with the movement of the asphalt. Grassy vegetation extends along the edges of the lake merging into the surrounding country.

The crude asphalt is loaded on small cars run by cable over the lake in a loop, the rails being supported by wooden ties which must be replaced

¹ Report of the Inspector of Asphalt and Cement, Engineering Department, District of Columbia, Wash., D. C., 1892: "On the Nature and Origin of Asphalt," published by the Barber Asphalt Paving Co., Long Island City, N. Y., Oct., 1898: "The Modern Asphalt Pavement," by Clifford Richardson, 1908, p. 176 et seq.: "Trinidad and Bermudez Lake Asphalt and Their Use in Highway Construction," by Clifford Richardson (pamphlet): "The Wonderland of Trinidad," issued by the Barber Asphalt Paving Co. (pamphlet): "An Examination of Some Bituminous Minerals," by F. C. Garrett, *J. Soc. Chem. Ind.*, **31**, 314, 1912; "The Proximate Composition and Physical Structure of Trinidad Asphalt," by Clifford Richardson, *Proc. Am. Soc. Testing Materials*, **6**, 509, 1906; "Studies in Asphalt," by C. J. Frankforter, *J. Ind. Eng. Chem.*, **2**, 239, 1910; "The Hydrocarbons of Utah," by Bardwell, et al., *J. Ind. Eng. Chem.*, **5**, 973, 1913; also **6**, 865, 1914,

from time to time as they gradually sink into the surface of the asphalt. The asphalt is transferred to an inclined cable way at the end of the loop which runs to the shore, and thence to a long pier where it is dumped on board steamers. (Fig. 40.)

It has been estimated that the lake contains over 9 million tons of asphalt. Although vast quantities have been removed in the past, the

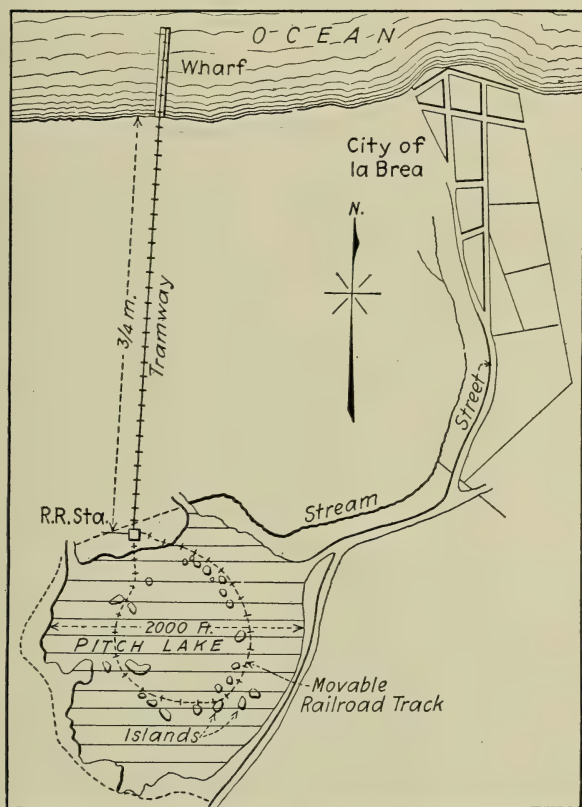
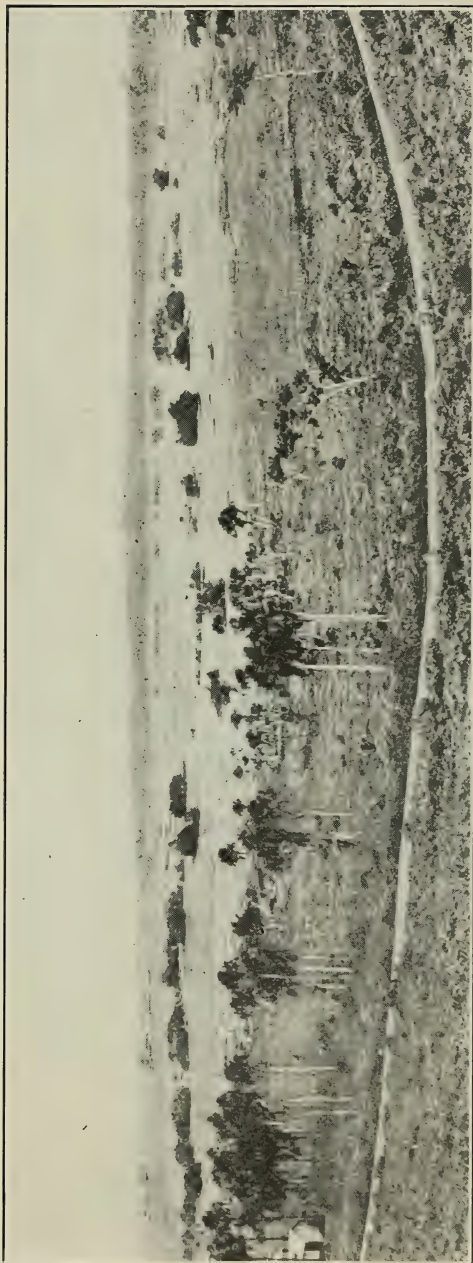

FIG. 35.—Map of Trinidad Asphalt Lake.

level of the lake has not sunk more than 8 to 10 ft. since the rate of influx closely approximates the quantity removed.

The fresh material consists of an emulsion of asphalt, gas, water, sand and clay. According to Richardson¹ oil sands occurring at a depth

¹"A Unique Geophysical Phenomenon, Trinidad Asphalt, Interesting from the View of Dispersoid Chemistry," *J. Phys. Chem.* **19**, 241, 1915; "The Nature and Origin of Petroleum and Asphalt," by Clifford Richardson, *Met. Chem. Eng.* **16**, 3, 1917; *Eng. Chem.* **8**, 4, 1916.



Courtesy of Barber Asphalt Co.

FIG. 36.—Panoramic View of Trinidad Lake.



Courtesy of Barber Asphalt Paving Co.

FIG. 37.—Folds in the Surface of Trinidad Lake.

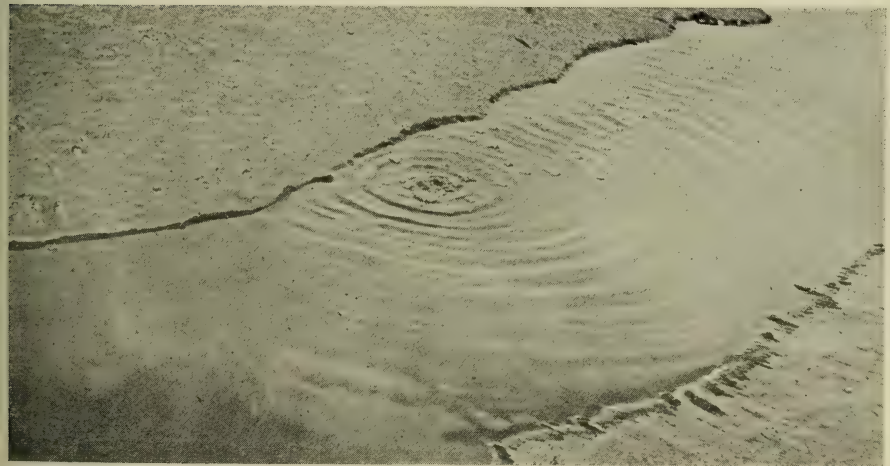

Courtesy of Barber Asphalt Paving Co.

FIG. 38.—Evolution of Gas from Trinidad Lake.

carry an asphaltic petroleum and natural gas under high pressure, which on coming in contact with a paste of colloidal clay and silica are converted into the asphalt which emerges at the surface. (See page 55.)



Courtesy of Barber Asphalt Paving Co.

FIG. 39.—Gathering Trinidad Lake Asphalt.



Courtesy of Barber Asphalt Paving Co.

FIG. 40.—Transporting Trinidad Lake Asphalt.

The crude Trinidad lake asphalt is extremely uniform in composition, as is evident from analyses of samples taken from different points over the surface, calculated on a water- and gas-free basis.

The crude material, when freshly sampled at the centre of the lake is composed of:

Water and gas volatilized at 100° C.....	29.0%
Asphalt soluble in carbon disulphide.....	39.0%
Asphalt absorbed by mineral matter.....	0.3%
Mineral matter on ignition with tricalcium-phosphate.....	27.2%
Water of hydration in mineral matter.....	4.3%
Total.....	99.8%

Specimens taken from various portions of the lake's surface, after pulverizing and drying to constant weight in air at room temperature, appear fairly uniform in composition, averaging:

Soluble in carbon disulphide.....	55.0%
Free mineral matter.....	35.5%
Water of hydration, etc.....	9.7%

The so-called "Water of hydration, etc." includes water chemically combined with the clay, asphalt absorbed by the clay and not removable by carbon disulphide and the inorganic salts which are volatilized on ignition upon determining the mineral matter.

The emulsified water contains mineral constituents in solution to the extent of 82.1 grams (at 110° C.) per kilo, composed largely of sodium chloride. The gas is a mixture of methane, carbon dioxide, hydrogen and hydrogen sulphide. The mineral matter consists of extremely finely divided silica and colloidal clay.

The crude asphalt is subjected to a refining process by heating it to 160° C. to drive off the water. A small amount of volatile matter is also removed during this treatment. The refined asphalt tests as follows:

(Test 1) Color in mass.....	Black
(Test 4) Fracture.....	Conchoidal
(Test 5) Lustre.....	Dull
(Test 6) Streak.....	Black
(Test 7) Specific gravity at 77° F.....	1.40-1.42
(Test 9a) Hardness, Moh's scale.....	1 -2
(Test 9b) Penetration at 115° F.....	10 -15
Penetration at 77° F.....	1.5 -4.0
Penetration at 32° F.....	0.25-0.75
(Test 9c) Consistency at 115° F.....	32.7
Consistency at 77° F.....	74.9
Consistency at 32° F.....	Above 100
(Test 9d) Susceptibility factor.....	Greater than 80
(Test 10a) Ductility (Dow Method):	
At 115° F.....	8.0
At 77° F.....	1.8
At 32° F.....	0.1
(Test 10b) Ductility (Author's Method):	
At 115° F.....	1.5
At 77° F.....	1.0
At 32° F.....	0.0

(Test 11)	Tensile strength (Author's Method):	
	At 115° F.....	4.15
	At 77° F.....	21.0
	At 32° F.....	27.0
(Test 14a)	Behavior on heating:	
	At 0° C.....	Brittle, crumbled rather easily
	From 5 to 10° C.....	Slightly brittle, not "crumbly"
	From 20 to 25° C.....	Less brittle, not "crumbly"
	From 45 to 50° C.....	No apparent change
	From 65 to 70° C.....	Begins to soften
	From 102 to 108° C.....	Entirely melted
	From 120 to 125° C.....	Consistency of molasses, ap- peared stringy or fibrous when stirred
	From 150 to 155° C.....	Slightly mobile
	From 170 to 175° C.....	Very mobile
	From 208 to 210° C.....	Flashes
	From 233 to 235° C.....	Burns
(Test 15a)	Fusing-point refined asphalt (K. and S. method).....	188° F.
(Test 15a)	Fusing-point, pure asphalt extracted from mineral matter.....	131½° F.
(Test 15d)	Temperature at which it flows.....	190° F.
(Test 16)	Volatile at 325° F., in 7 hrs.....	1.1-1.7%
	Volatile at 400° F., in 7 hrs.....	4.0-5.25
(Test 19)	Fixed carbon.....	10.8-12.0%
(Test 20)	Distillation test:	
	0-150° C.....	14.93%
	150-200° C.....	10.42%
	200-250° C.....	2.26%
	Coke and ash.....	72.39%
	Total.....	100.00%
(Test 21)	Soluble in carbon disulphide.....	56-57%
	Asphalt retained by mineral matter.....	0.3%
	Mineral matter on ignition with tricalcium- phosphate.....	38.5%
	Water of hydration (clay and silicates).....	4.2%
(Test 22)	Carbenes.....	0.0-1.3%
(Test 23)	Soluble in 88° naphtha (pure asphalt).....	62-64%
(Test 24)	Grams crude dry material soluble in 100 grams cold solvent:	
	Amyl acetate.....	132
	Amyl alcohol.....	Insoluble
	Amyl nitrate.....	84
	Aniline.....	3
	Benzol.....	48
	Carbon disulphide.....	In all proportions
	Carbon tetrachloride.....	In all proportions
	Chloroform.....	10
	Ethyl acetate.....	30
	Ethyl alcohol.....	Insoluble
	Ethyl ether.....	109
	Nitrobenzene.....	39
	Propyl alcohol.....	Insoluble
	Toluol.....	39
	Turpentine.....	115
	Solubility of pure asphalt upon extraction cold by:	
	Acetone.....	21.7%
	Benzol.....	99.9%
	Chloroform.....	93.4%
	Ethyl ether.....	68.9%

(Test 26)	Carbon.....	80-82%
(Test 27)	Hydrogen.....	10-11%
(Test 28)	Sulphur.....	6- 8%
(Test 29)	Nitrogen.....	0.5-0.8%
(Test 33)	Paraffine.....	0.0%
(Test 34)	Saturated hydrocarbons.....	24.4%
(Test 37d)	Saponification value.....	40.0
(Test 38a)	Free asphaltous acids.....	6.4%
(Test 38b)	Asphaltous acid anhydrides.....	3.9%
(Test 38c)	Asphaltenes.....	37.0%
(Test 38d)	Asphaltic resins.....	23.0%
(Test 38e)	Oily constituents.....	31.0%

So-called Trinidad "land asphalt" represents material which overflows from the lake at its edges, where it has been exposed to the action of the weather for centuries. It is derived from the same source as the lake asphalt, and has the same general physical and chemical characteristics. It is known under various names; for example: "cheese pitch" is a variety which resembles the lake asphalt most closely with respect to its containing gas cavities; "iron pitch" is a variety which has hardened on exposure to the weather to such a degree that it resembles refined lake asphalt; "cokey pitch" is a variety which has been coked or carbonized by brush fires, etc.

The land asphalt varies in its composition from place to place, but differs from the lake asphalt in the following respects:

- (1) It contains little to no gas or water.
- (2) It contains a slightly higher percentage of mineral matter (from 1 to 2 per cent).
- (3) More of the volatile ingredients have been evaporated.

These influence the tests as follows:

The specific gravity is somewhat higher (up to 1.45).

The hardness is greater.

The fusing- and flowing-points are higher (between 30 and 40° F.).

The volatile matter is less (about 1 per cent).

The percentage of fixed carbon is slightly higher (about 2 per cent).

The following table shows the quantity of asphalt produced during the years 1912-1916, in long tons:

TABLE XXIV

Year.	TO UNITED STATES.			TO EUROPE.			TO OTHER COUNTRIES.			Grand total.
	Lake.	Land.	Total.	Lake.	Land.	Total.	Lake.	Land.	Total.	
1912.....	95,111	8,600	103,711	85,299	85,299	486	486	189,496
1913.....	123,873	1,400	125,273	104,153	104,153	605	605	230,031
1914.....	67,357	2,950	70,307	75,297	75,297	145,604
1915.....	118,001	1,250	119,251	18,025	18,025	136,026
1916.....	117,719	117,719	13,380	13,380	131,099

ARGENTINE

Province of Jujuy. An asphalt lake, known as the "Laguna de la Brea," occurs some distance northeast of the City of Jujuy. The asphalt is sulphurous, of a semi-liquid consistency which hardens at the edges. It is mixed with more or less earthy constituents. Seepages of mineral oil are also found locally.

Province of Chubut. Deposits of soft, impure asphalt are reported in the village of Comodoro Rivadavia, associated with seepages of asphaltic petroleum. The asphalt has not been developed, and no analyses are available.

EUROPE

FRANCE

Department of Landes. Near Bastennes, a moderately large-sized deposit of asphaltic sand is found, associated with fossil shells, indicating that this asphalt is of animal (marine) origin. These shells are distributed throughout the asphalt bed, which measures between 10 and 14 ft. thick. On exposure to the air, the shells fall to pieces in a fine powder and the asphalt hardens materially, due to the loss of volatile matter. An analysis by L. Malo shows the material to contain: asphalt 38.45 per cent, calcium carbonate 4.96 per cent, and sand 56.59 per cent.

Department of Gard. Very large deposits of rock asphalt occur in this Department, embracing in the north the Concessions of St. Jean-de-Maruejois, and in the south including the Concessions of Servas, Cauvas, Sumades and Puech. These have long been known and worked for many years. Deposits of lignite and coal occur in the same region. The asphalt is associated with limestone, sandstone and shale, and varies in percentage between 5 and 16 per cent. An average analysis shows it to contain: asphalt 10 to 12 per cent, clay 0.5 to 0.8 per cent, calcium carbonate 84-86 per cent, magnesium carbonate about 2 per cent, and moisture 0.5 per cent.

Department Haute-Savoie. Deposits of asphalt associated with limestone and sandstone occur at Mussiéges, Frangy, Lovagny, Bourbonne, and Chavaroche, in strata between 13 and 16 ft. thick. An analysis of the rock asphalt mined at Chavaroche shows it to contain: asphalt 29.2 per cent, calcium carbonate 51.6 per cent, and sand 19.2 per cent. This is used for paving purposes.

Department of Ain. At Bellegarde in the northern part of the Department occurs a deposit of asphaltic limestone unevenly impregnated with asphalt, and also associated in part with heavy petroleum oils.

The well-known Seyssel deposits also occur in this Department at Pymont, Volant and Challonges, consisting of a fine-grained limestone impregnated with asphalt. This region is shown in Fig. 41. The deposits consist of a series of hillside quarries along the Rhone River. The asphaltic impregnation varies from 2 to 8 per cent as a maximum, the balance consisting almost exclusively of calcium carbonate. Fossil shells are frequently encountered, also crystalline calcite. The deposits at Pymont are now largely exhausted, after having been worked for

many years. The Volant deposits are still being worked actively. According to L. Malo the asphalt extracted from the Seyssel deposits tests as follows:

Water.....	1.9 - 0.0%
Asphalt (Fusing-point, 87° F., K. and S. method).....	8.00-8.15%
Magnesium carbonate.....	0.10%
Calcium carbonate.....	89.55-91.30%
Insoluble in acid.....	0.10- 0.45%
Loss, etc.....	0.25%

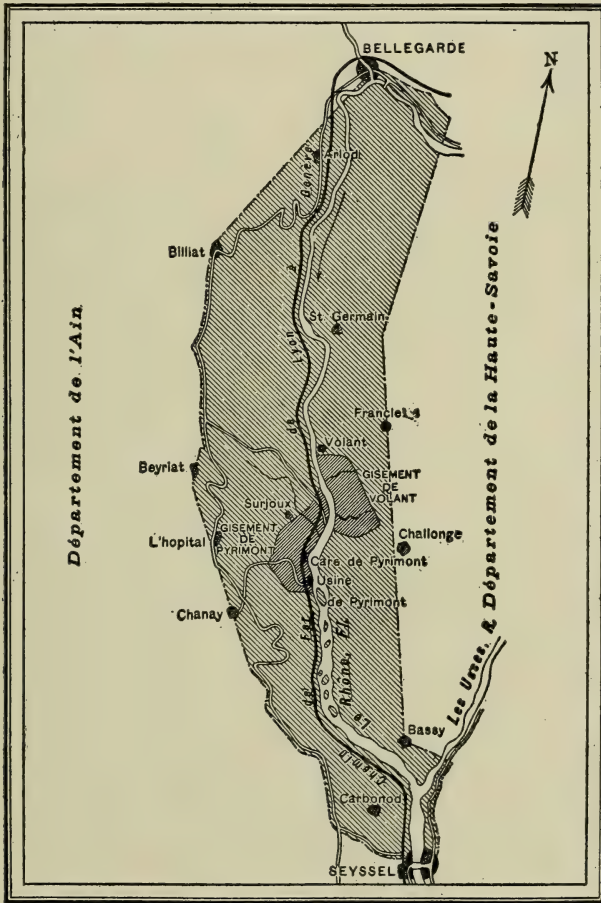

FIG. 41.—Map of Seyssel Asphalt Deposit, France.

SWITZERLAND

Extensive deposits of asphalt impregnated limestone occur west of Neuchatel Lake, in the so-called Val de Travers region. These

have been exploited for many years and marketed under the names "Neuchatel Asphalt" and "Val de Travers Asphalt." The exact location of the region is shown in Fig. 42. The percentage of asphalt varies considerably; thus, the "ordinary" grade contains about 10.7 per cent of asphalt, the so-called "rich" grade contains 15.3 per cent of asphalt, the "extra" grade 17.5 per cent and the "powder" 9.6 per cent.

The average product contains: asphalt 10.15 per cent (fusing-point 50° F., K. and S. method), calcium carbonate 88.4 per cent, iron and aluminium oxides 0.25 per cent, magnesium carbonate 0.3 per cent, matter insoluble in acid 0.45 per cent, and loss 0.45 per cent. The theory has

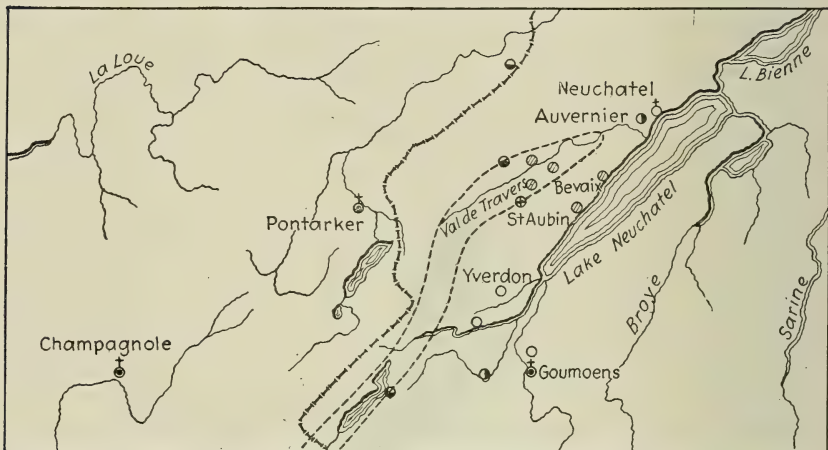

FIG. 42.—Map of Neuchatel (Val-de-Travers) Asphalt Region, Switzerland.

been advanced that these asphalts have been produced by the decomposition of marine animal and vegetable matters, which is borne out by the associated fossils.

Smaller deposits occur at Auvernier, Bevaix, and St. Aubin, south of Neuchatel, on the western shore of Lake Neuchatel, containing smaller percentages of asphalt than the preceding.

ALSACE-LORRAINE

The deposits in this region occur in a well-defined area in the neighborhood of Lobsann a short distance north of Strassburg, as shown in Fig. 43. The asphalt strata have been traced 6 to 7 miles, extending through Sulz u. Wald, Pechelbronn and Lampertsloch. They occur as asphalt-impregnated limestone and sandstone associated with lignite. Petroleum is also found locally. The asphal-

strata average about 80 ft. in thickness and carry many fossils. The region is badly faulted. The bituminous limestone has the following average composition:

Asphalt (Fusing-point 77° F., K. and S. method).....	11.9 -12.32%
Calcium carbonate.....	69.0 -71.43%
Iron and aluminium oxides.....	4.3 - 5.9%
Sulphur.....	5.0 - 5.6%
Magnesium carbonate.....	0.3%
Silica.....	3.15- 3.65%
Loss, etc.....	1.7 - 3.4%

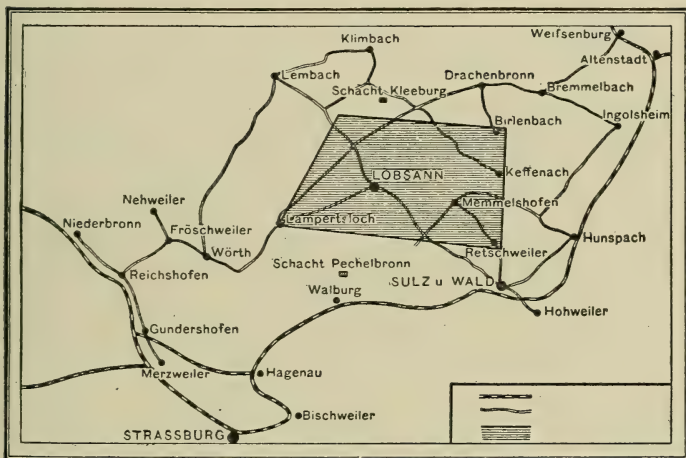

FIG. 43.—Map of Lobsann Asphalt Region, Alsace-Lorraine.

The asphaltic sandstone at Pechelbronn occurs in veins 3 to 6 ft. thick, containing a soft, viscous asphalt which, when extracted shows a gravity between 0.90 and 0.97 at 77° F. Large quantities of asphalt have been mined in this region for paving purposes.

GERMANY

Province of Hanover. At Limmer, as small village near Ahlem in the plains of Acker, about 18 miles west of Hanover there occurs a deposit of asphaltic limestone measuring 1600 by 2250 ft. which has been worked for several hundred years. The vein has the general cross-section shown in Fig. 44, and is worked by open quarrying.¹ The rock carries between 8 and 20 per cent of asphalt and contains numerous fossil shells. As freshly mined it has a brownish to gray-brown color, and the asphalt

¹ Where *a* represents alluvium; *b*, asphalt-impregnated limestone; *c*, clay; *d*, asphalt-impregnated limestone; *e*, shale; and *f*, limestone.

impregnation is very soft in consistency, containing a large proportion of volatile constituents. The average analysis shows:

Asphalt (Fusing-point 61° F., K. and S. method).....	13.4-14.3%
Calcium carbonate.....	67%
Iron and aluminium oxides, etc.....	17.5-19.5%
Loss.....	0.3- 1.18%

At Waltersberge, near Limmer, a very large deposit of asphaltic limestone is found, containing 5 to 7 per cent of asphalt. It is estimated that about 3,000,000 tons occur in this deposit, but the material is so poor in asphalt that it must be enriched by mixing with Limmer or Trinidad asphalt.

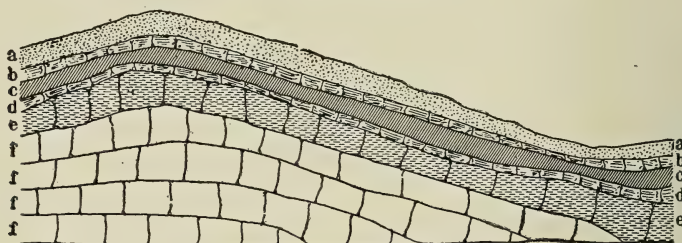

FIG. 44.—Cross-Section of Limmer Asphalt Deposit, Germany.

At Holzen, a small village on the River Ith, a short distance north of Vorwohle, occurs a well known, and one of the most productive asphalt deposits in Germany. The asphalt stratum has been traced for approximately 14,500 ft. and forms a succession of layers 65 ft. thick carrying a variable percentage of asphalt associated with limestone, and separated with clay and shale. The rock asphalt analyzes as follows:

Asphalt (Fusing-point 65-70° F., K. and S. method).....	5.4 - 8.5%
Calcium carbonate.....	80.0 -90.9%
Iron and aluminium oxides.....	4.0 - 5.0%
Silica.....	2.55- 4.77%
Loss.....	0.15- 2.11%

A small deposit has been reported at Wintjeberg in this same neighborhood, but has not been worked to any extent.

Province of Westphalia. Minor deposits have been found near the villages of Darfeld, Buldern, Hangenau, and Appelhülsen, associated with clay and shale.

Province of Hessen. At Mettenheim between Worms and Appenheim, occurs a deposit of asphaltic limestone and clay carrying a large quantity of fossil fish remains. The rock contains between 74.4 and 82.6 per cent of asphalt of a comparatively high fusing-point.

AUSTRIA

Province of Dalmatia

Vrgorac. A deposit of asphaltic limestone occurs at Vrgorac, having a specific gravity at 77° F. of 1.697 containing an average of 26 per cent of asphalt. Analyses show the following ingredients:

	Analysis 1, Per Cent.	Analysis 2, Per Cent.	Analysis 3, Per Cent.
Asphalt.....	2.94	7.12	38.92
Silica.....	21.70
Iron and aluminium oxides.....	7.12	58.10
Iron carbonate.....	1.10
Calcium carbonate.....	36.60	61.08
Magnesium carbonate.....	32.58
Sodium chloride.....	0.97
Water.....	4.10
Total.....	100.00	99.87	100.00

The first analysis represents an asphaltic limestone containing silica, the second analysis represents an asphaltic shale, and the third an asphaltic limestone (pure). Considerable asphalt has been derived from this deposit for paving purposes.

Asphaltic shales have been reported near the town of Skrip, on the Island of Brazza, situated near the coast of Austria, in the Adriatic Sea, containing between 15 and 40 per cent of very soft asphalt. The layers are between 2 and 4 ft. in thickness. There also occurs a deposit of asphaltic limestone containing about 13 per cent of asphalt and 87 per cent of calcium carbonate, having a brownish-black color and containing a substantial proportion of volatile matter.

At Morowitz near Sebenico, on the Adriatic Sea, occurs a deposit of asphaltic limestone carrying 10 to 15 per cent of asphalt, 95 per cent of calcium carbonate, and about 4 per cent of magnesium carbonate.

At Porto Mandorlo, near the town of Trau on the Adriatic Sea, occur beds of crystalline limestone of a brownish color containing 9.2 per cent of asphalt and 90.8 per cent of calcium carbonate. Further deposits have been located in this region at Biskupija and Vinjisce.

Province of Tyrol. A very peculiar asphaltic shale occurs at Seefeld, 5000 ft. above the sea-level, in beds several feet thick with numerous fossil fish remains, in between layers of dolomite. This deposit constitutes one of the main sources of supply of ichthyol, which is recovered upon subjecting the material to a process of destructive distillation in suitable retorts. The material best suited for this purpose is composed of the following:

Asphalt.....	26.41%
Calcium and magnesium carbonates.....	38.22%
Clay.....	6.67%
Silica.....	19.03%
Iron oxide.....	5.95%
Loss and moisture.....	3.72%
Total.....	100.00%

Province of Bihar

Deposits of asphaltic sand occur at Tataros containing approximately 15 per cent of soft, sticky asphalt with a characteristic penetrating odor. It is found in strata between 6 and 25 ft. thick, 5000 ft. long and 4000 ft. wide. Large quantities of asphalt have been mined from this deposit, which constitutes one of the largest sources of supply in Austria. Analysis shows between 15 and 22 per cent asphalt, fusing at 83° F. (K. and S. method). The water-extraction process has

been used to separate a semi-liquid asphalt from the sand, leaving a residue containing 3 per cent of asphalt which could not be separated. The pure, soft asphalt thus separated is distilled to recover the heavy oils and then converted into mastic by mixing with limestone.

An asphaltic sand deposit associated with lignite is found a few miles northwest of Bodonos containing between 11 and 15 per cent of asphalt.

A short distance east of Felsö Derna there occurs a bed of sand asphalt, very similar in character and composition to that found at Tataros, carrying 15 to 22 per cent of asphalt. The extracted asphalt contains 0.73 per cent of sulphur, 5.4 per cent of ash, and 1.6 per cent of crystallizable paraffine.¹

Province of Herzegovina

A deposit of asphaltic limestone occurs at the village of Popovo Polje, having a black to grayish-black color, and carrying between 16 to 20 per cent of asphalt. It contains a large percentage of volatile matter, which causes the crude material to ignite very readily and burn with a luminous flame.

A little south of the village of Mišljan, and east of the town of Popovo Polje, occurs another and larger deposit of asphaltic limestone 6 to 20 ft. thick. The asphaltic impregnation is sticky and semi-liquid, varying between 3 and 35 per cent. The richer varieties ignite readily and burn with a luminous, smoky flame.

A deposit of asphaltic limestone about 100 ft. wide and 10 ft. thick occurs at Dračevo, about 2½ miles east of the city of Metkovic. The rock is of a brownish black to dull black color, carrying 5.4 per cent of asphalt. It is not rich enough to be worked profitably.

ITALY

Compartment of Marches

Province of Pesaro ed Urbino. Impure, solid asphalt is found at Sant' Agata Feltria associated with sulphur, but is not mined actively. At Tallamello and Urbino, deposits of solid and semi-liquid asphalt occur associated with more or less sulphur. These are merely of interest from a geological standpoint.

Compartment of Abruzzi ed Molise

Province of Abruzzo Citeriore. Minor occurrences have been reported at Tocco di Casauri, Valle San Leonardo, Sant' Ensemia a Majella, Ceramanico, Salle, Circondario di Lanziano and Palena. In the neighborhood of San Valentino, extensive deposits of asphaltic limestone have been worked in strata 2½ to 3 miles long and about 100 ft. thick. Quarries have been opened up in the Valley of the Pescara River at the villages of Roccamorce, Abateggio, Manopello, Lettomanopello, Tocco, and Papoli. Three distinct zones are distinguished. The lower carries between 9 and 10 per cent of asphalt, the middle an average of 17 per cent, and the upper 9 to 30 per cent. In certain localities the asphalt has a rubbery consistency, and is deep black in color, and in others it is very soft and semi-liquid. The deposits are rich in fossil shells. Analyses show the following composition:

Asphalt.....	10.62- 5.70%
Silica.....	0.06- 0.48%
Calcium carbonate.....	49.70-86.40%
Magnesium carbonate.....	1.20-32.0%
Iron and aluminium oxides.....	0.16- 1.18%
Moisture.....	0.22- 0.98%

¹ J. Marcussou, *Chem. Rev. Fett-Harz-Ind.*, 19, 171, 1912.

Compartment of Calabria

Province of Basilicata (Potenza). Asphaltic limestone deposits have been reported at Tamutola, Magliano, Setere and Leviano.

Compartment of Campania

Province Terra di Lavoro (Caserta). One of the largest asphalt quarries in the entire region, which, however, has not been very active in recent years, occurs at Colle San Magno. Analyses of the product as mined show it to be composed of the following:

Asphalt.....	7.15%
Calcium carbonate.....	73.76%
Calcium sulphate.....	1.72%
Iron and aluminium oxides.....	3.02%
Magnesium carbonate.....	14.24%
Silica.....	0.10%

Similar deposits of asphaltic limestone occur at Liri, Frosinone, Monte San Giovanni, Banco, Castro dei Volsci and Fillettino.

Compartment of Sicily.

Province of Syracuse. The largest and most important Italian asphalt deposit occurs at Ragusa, about 13 miles from the southern coast of Sicily, on the River Irminio, in a bed 16 to 64 ft. thick, and 1600 to 2000 ft. long. It contains variable percentages of asphalt, ranging from 2 to 30 per cent, associated with a soft limestone composed largely of fossil shell remains. Two varieties of rock asphalt are mined—a brown variety relatively poor in asphalt, containing between 3 and 7 per cent, and a black variety carrying an average of 15 per cent. It has been worked for many years, and over 100,000 tons are mined annually for use on the continent of Europe, being marketed in the form of a powder especially suitable for compressed asphalt pavements. The material as mined requires no further treatment other than grinding. Analyses show the following compositions:

Asphalt.....	8.80-14.05%
Calcium carbonate.....	82.15-88.21%
Iron and aluminium oxides.....	0.91- 1.90%
Magnesium carbonate.....	0.96%
Silica.....	0.60- 0.73%
Moisture and loss.....	0.40- 1.17%

The rock asphalt is also removed in large blocks which are capable of being sawed, bored, or carved in the form of paving stones, stair treads, or ornamental work for buildings. The dark color of the asphalt as freshly mined soon disappears upon exposure to the weather, turning to a bluish gray.

GREECE

District of Triphily

At Marathonpolis on the west coast of Peloponnes, there occurs a deposit of asphaltic limestone well suited for the preparation of asphalt mastic pavements, analyzing as follows:

Asphalt.....	14.75%
Silica.....	1.07%
Iron and aluminium oxides.....	0.80%
Calcium sulphate.....	0.21%
Magnesium carbonate.....	0.45%
Calcium carbonate.....	82.27%
Moisture and loss.....	0.45%
Total.....	100.00%

The asphalt is reported to have a comparatively high fusing-point.

PORTUGAL

Province of Estremadura. At Serra de Cabaço deposits of asphaltic sandstone have been reported, and at Monte Real, north of Leira, layers of asphaltic sandstone impregnated with a very soft and viscous asphalt exist. None of these have been worked to any great extent.

SPAIN

Province of Santander. In the neighborhood of Puerto del Escudo, deposits of asphaltic sandstone are found in beds about 5 ft. thick. No analyses are available. At Suances similar deposits of asphaltic sandstone have been reported containing approximately 11 per cent of asphalt.

Province of Alava. At Alauri and other localities in the Pyrenees, asphaltic sandstone deposits containing 12 to 20 per cent of asphalt have been worked for a number of years. A mine about 10 miles from Vittoria consists of a calcareous sandstone impregnated with 8 to 9 per cent of asphalt. It shows the following average composition:

Asphalt.....	8.80%
Silica.....	68.75%
Iron and aluminium oxides.....	4.35%
Calcium and magnesium carbonates.....	17.25%
Water and loss.....	0.40%

Province of Navarre. Similar deposits have been reported at Bocaicoa, which have been worked to a limited extent.

Province of Tarragona. In the Santa Catalina mountains outcrops of asphaltic shale are reported. No data concerning these are available.

Province of Soria. At Santander and Sierra de Frentes several deposits of asphaltic sandstone have been operated, from which fairly large quantities have been mined.

RUSSIA

Province of Terek

At Vladikavkaz near the city of Gudermes an asphalt deposit has been known to exist for some time, containing between 6 and 12 per cent of a very soft asphalt associated with earthy matter.

At Michaelovskaja in the Caucasus Mountains, a rich deposit is found, containing 86½ per cent of asphalt and the balance mineral matter. The extracted asphalt melts at about 300° C., and is extremely hard and brittle, having a specific gravity of about 1.2. The portion soluble in carbon disulphide contains: carbon

75.42 per cent, hydrogen 7.86 per cent, nitrogen 0.06 per cent, sulphur 0.8 per cent, and ash 4.35 per cent.¹

Near Sernowodsk in this same region, a similar deposit of asphalt is found associated with clay, which analyzes similarly to the preceding.

Province of Simbirsk

Extensive deposits of asphalt are found at Syzran, along the banks of the Syzranka River, extending to the Samarskaya-Luka Mountains. The product as mined has the following composition:

Asphalt.....	30.50%
Calcium carbonate.....	66.23%
Magnesium carbonate.....	3.27%
Total.....	100.00%

In this same region near the River Volga there is an occurrence of liquid asphalt containing about 20 per cent asphalt associated with sand, covering an area 1300 by 320 ft. in a layer about 32 ft. deep.

ASIA

JAPAN

Ugo Province. An asphalt deposit has been reported in this locality, but no exact data are available.²

ASIATIC RUSSIA

Province of Uralsk. At the mouth of the Ural River, where it empties into the Caspian Sea, deposits of asphalt have been found, but no complete data or analyses are reported.

SYRIA

At Mrani, deposits of asphaltic limestone have been reported containing between 10 and 30 per cent of asphalt.

A large deposit is located at Bir-el-Hummar a short distance from Hasbaya (see p 135) composed of limestone impregnated with an average of 10 per cent of asphalt. Petrified fish remains are also present, indicating that it is of animal origin. It is said to have a comparatively high fusing-point. Similar deposits have been reported at Khaliwet, between Hasbaya and Rascheya, also at Ain-Ettineh, 70 miles east of Beirut.³

Deposits of asphaltic limestone are reported on the eastern shore of the Dead Sea between Kerak and Ouadi Kerak, also on the western shore near Masada and Ouadi Sebbi. A short distance from this locality, on the Ouadi River, peculiar formations occur, composed of flint pebbles cemented together with varying percentages of asphalt. This asphaltic conglomerate lies in juxtaposition to a vein of asphaltic limestone.

¹"New Deposits of Asphaltum," K. Charitschkow, *Chem.-Zeit.*, **31**, Rep. 116, 1907.

²Rychei Katayama, *Beiträge zur Mineralogie von Japan*, **5**, 303, 1915; *Chem. Abs.*, **10**, 1831, 1916.

³"Asphalt Mines in Syria," Reports from the Consuls of the U. S., **42**, [153], 228, 1893.

Asphaltic limestone is also found at Nebi Mousa, on the northwest shore of the Dead Sea, containing 25 per cent of asphalt, also a quantity of fossil marine remains. It is used by the natives as a fuel and for paving purposes. Similar deposits have been reported at Tiberias, Hamman and Jarmuktale.

MESOPOTAMIA

At Hit on the Euphrates River, asphaltic limestone is still found, and collected in a crude way by the natives, exactly as was the case many centuries before. (See page 5.)

ARABIA

In 1902 an extensive deposit was discovered on the Island of Bahrein, in the Persian Gulf, which on analysis was found to consist of:

Asphalt.....	22.77%
Ash.....	76.68%
Moisture.....	0.59%
Total.....	100.04%

The ash consists almost exclusively of calcium-aluminium-silicate. The product is mixed with limestone powder and used for paving purposes.

AFRICA

ALGERIA

Province of Oran. At Constantine, asphaltic limestone is found in veins 32 ft. thick, containing as much as 40 per cent of asphalt. In many places the rock is so saturated that the asphalt seeps out and forms pools having a fusing-point of about 140° F. (K. and S. method), a penetration of 11 at 77° F., and containing 0.9 per cent of sulphur. The limestone is largely crystalline.

NIGERIA

Bituminous sands are reported in southern Nigeria a short distance from the coast. Attempts have been made to purify the asphalt by the water-extraction process, but so far this has resulted in failure. The extracted material contains about 70 per cent of asphalt, 10 per cent of organic substances other than asphalt and 20 per cent of sand.

RHODESIA

Rock asphalt has recently been reported in northern Rhodesia, but is not yet thoroughly investigated.

CHAPTER X

ASPHALTITES

ASPHALTITES are natural asphalt-like substances, characterized by their high fusing-points (over 250° F.). They are grouped into three classes, namely: gilsonite, glance pitch, and grahamite. Since all are presumably derived from the metamorphosis of petroleum, one would naturally expect the classes to merge into one another, and such actually proves to be the case.

The author has adopted the following means of differentiating the three classes, one from another:

	Streak.	Specific Gravity at 77° F.	Fusibility, (K. & S. Method) Deg. F.	Fixed Carbon Per Cent.
Gilsonite or Uintaite.....	Brown	1.05-1.10	250-350	10-20
Glance Pitch or Manjak *.....	Black	1.10-1.15	250-350	20-30
Grahamite*.....	Black	1.15-1.20	350-600	30-55

* When substantially free from mineral matter.

In all three classes the non-mineral constituents are almost completely soluble in carbon disulphide. The physical and chemical characteristics will be described in greater detail under the respective headings.

GILSONITE OR UINTAITE

This asphaltite is found in but one region,¹ extending from the eastern portion of the State of Utah across the boundary line into the western portion of Colorado. It occurs in a number of parallel vertical veins, varying in width from thin fissures to several feet.

¹ "Gilsonite or Uintaite," J. M. Locke, *Trans. Am. Inst. Mining Eng.*, **16**, 162, 1887; "Notes on a Specimen of Gilsonite from Uinta County, Utah," R. W. Raymond, *Trans. Am. Inst. Mining Eng.*, **17**, 113, 1888; "Nature of Uintaite," Dr. Henry Wurtz, *Eng. and Mining J.*, **48**, 114, 1889; "The Uintaite (Gilsonite) Deposits of Utah," by G. H. Eldridge, 17th Annual Report U. S. Geol. Survey, Wash., D. C., p. 915, 1896; W. T. Day, *J. Franklin Inst.*, **160**, 221, 1896; 22d Annual Report of the U. S. Geol. Survey, Wash., D. C., G. H. Eldridge, part I, pp. 327 and 340, 1901; "The Production of Asphalt, Related Bitumens and Bituminous Rock in 1910," by D. T. Day, U. S. Geol. Survey, Wash., D. C., p. 6, 1911; "Modern Asphalt, Pavement," p. 208, 1908; "The Hydrocarbons of Utah," by Bardwell, et al., *J. Ind. Eng. Chem.*, **5**, 973, 1913; **6**, 865, 1914; "Gilsonite and Grahamite," by Clifford Richardson, *J. Ind. Eng. Chem.*, **8**, 496, 1916.

In all the veins the gilsonite is fairly uniform in composition and complies with the following characteristics:

(Test 1)	Color mass.....	Black
(Test 4)	Fracture.....	Conchoidal
(Test 5)	Lustre.....	Bright to fairly bright
(Test 6)	Streak.....	Brown
(Test 7)	Specific gravity at 77° F.....	1.05-1.10
(Test 9a)	Hardness on Moh's scale.....	2
(Test 9b)	Hardness, needle penetrometer at 77° F.....	0
(Test 9c)	Hardness, consistometer at 115° F.....	40-60
	Hardness, consistometer at 77° F.....	90-120
	Hardness, consistometer at 32° F.....	Too hard for test
(Test 9d)	Susceptibility factor.....	> 100
(Test 10a)	Ductility at 77° F. (Author's Method).....	0
(Test 13)	Odor on heating.....	Characteristic
(Test 14a)	Behavior on melting.....	Forms a comparatively thick, viscous melt.
(Test 14b)	Behavior on heating in flame.....	Softens and flows
(Test 15a)	Fusing-point (K. and S. method).....	250-350° F.
(Test 15b)	Fusing-point (Ball and Ring method).....	270-370° F.
(Test 16)	Volatile at 325° F., 7 hrs. (dry substance).....	Less than 2%
	Volatile at 400° F., 7 hrs.....	Less than 4%
	Volatile at 500° F., 4 hrs.....	Less than 5%
(Test 19)	Fixed carbon.....	10-20%
(Test 20)	Distillation test:	
	0-150° C.....	9.34% distillate
	150-200° C.....	5.35% distillate
	200-250° C.....	12.84% distillate
	250-300° C.....	28.99% distillate
	Above 300° C.....	Coked
(Test 21a)	Soluble in carbon disulphide.....	Greater than 98%
(Test 21b)	Non-mineral matter insoluble.....	0-1%
(Test 21c)	Mineral matter.....	Tr.-1%
(Test 22)	Carbenes.....	0-½%
(Test 23)	Soluble in 88° naphtha.....	40-60%
(Test 24)	Grams soluble in 100 grams of cold solvent:	
	Amyl acetate.....	86
	Amyl alcohol.....	Insoluble
	Amyl nitrate.....	51
	Aniline.....	Insoluble
	Benzol.....	71
	Carbon disulphide.....	Soluble in all proportions
	Carbon tetrachloride.....	44
	Chloroform.....	54
	Ethyl acetate.....	3
	Ethyl alcohol.....	Insoluble
	Ethyl ether.....	Soluble in all proportions
	Naphtha 62°.....	5
	Nitrobenzene.....	9
	Propyl alcohol.....	Insoluble
	Toluol.....	72
	Turpentine.....	60
(Test 26)	Carbon.....	88-89.5
(Test 27)	Hydrogen.....	8.5-10.0
(Test 28)	Sulphur.....	1.7-2.0
(Test 29)	Nitrogen.....	0.8%
(Test 30)	Oxygen.....	0-2%

(Test 33)	Paraffine scale	0-Tr. %
(Test 35)	Sulphonation residue	85-95%
(Test 37)	Saponifiable matter	Tr.
(Test 41)	Diazo reaction	No.
(Test 42)	Anthraquinone reaction	No.

Gilsonite is assorted and marketed in two varieties, known as "selects" or "firsts," and "seconds" respectively. The "firsts" are taken from the centre of the vein and are characterized by a conchoidal and lustrous fracture. The "seconds" occur near the vein walls and are characterized by a semi-conchoidal and semi-lustrous fracture. In other respects, however, they are alike.

Fig. 45 shows the hardness, tensile strength (multiplied by 10) and ductility curves of a mixture of gilsonite and residual oil fluxed together so as to have

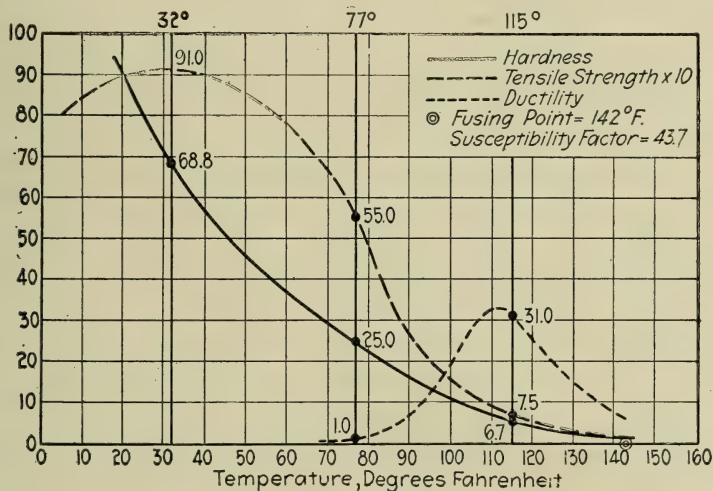

FIG. 45.—Chart of Physical Characteristics of Fluxed Gilsonite Mixture.

a hardness of exactly 25.0 at 77° F. The resulting mixture contained gilsonite, 47 per cent and residual oil, 53 per cent. The fusing-point of the gilsonite used was 285° F. (K. and S. method), and that of the resulting mixture 142° F.

Gilsonite is one of the most valuable asphalts for manufacturing paints and varnishes (see p. 471). Gilsonite and glance pitch mix readily in all proportions with fatty-acid pitches, thus differing from grahamite. Products involving the use of gilsonite formed the basis of several patents granted to Gilson, after whom the material was named.¹

¹ U. S. Patents 361,759 of Apr. 26, 1887; 362,076 of May 3, 1887; 415,864 of Nov. 26, 1889 to S. H. Gilson.

UNITED STATES

Utah.

Uinta County. Practically all gilsonite is mined in the "Uinta Basin," at the junction of the Green and White Rivers south of Fort Duchesne, Utah, from a point 4 to 5 miles within the Colorado boundary line (Rio Blanco county), extending westward about 60 miles into Utah. A large number of veins have been located in this area, and extending from a northwesterly to a southeasterly direction, and all of them parallel or nearly so. The veins vary in width from a fraction of an inch to 18 ft., and some of the longest, such as the Cowboy or Bonanza, have been traced 8 miles. The veins are almost vertical with fairly smooth and regular rock walls, and although they are usually continuous, they may in certain cases be interrupted in the direction of the fissure. Very frequently branch veins join the main one, forming very acute angles.

Near the outcrop where it has been exposed to the weather, gilsonite loses its brilliant lustre, changing to a dull black. Along the vein walls it shows a columnar structure, extending at right angles to the wall, which is characteristic of all asphaltites. The rock walls are often impregnated with gilsonite $\frac{1}{2}$ to 2 ft., so there is no visible line of demarcation between the impregnated and non-impregnated portions. In shale formation the impregnated zone is smaller than when the gilsonite is found in a porous sandstone.

The following are the principal veins occurring in this region:

Duchesne Vein. This occurs about 3 miles east of Fort Duchesne, filling a vertical crack in sandstone and shale. The vein has been traced for 3 miles, and is 3 to 4 ft. wide for about $1\frac{1}{2}$ miles, tapering at the ends, until it completely disappears. A comparatively large quantity of gilsonite has been mined from this vein.

Culmer Vein. This is also known as the "Pariette Mine," and occurs in the "Castle Peak" mining district. It has been traced 7 miles and varies in width from a fraction of an inch to 30 ins., averaging about a foot. Several branch veins are connected with the main one at very acute angles. It also shows a number of transverse faults as illustrated in Fig. 46, in which the lateral displacements vary from 1 to 10 ft. The associated rock consists of sandstone and shale.

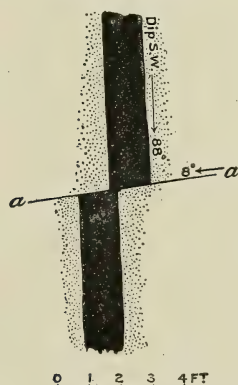

FIG. 46.—Faults in Gilsonite Vein.

Bonanza and Cowboy Veins. These are shown in Fig. 47 and embrace

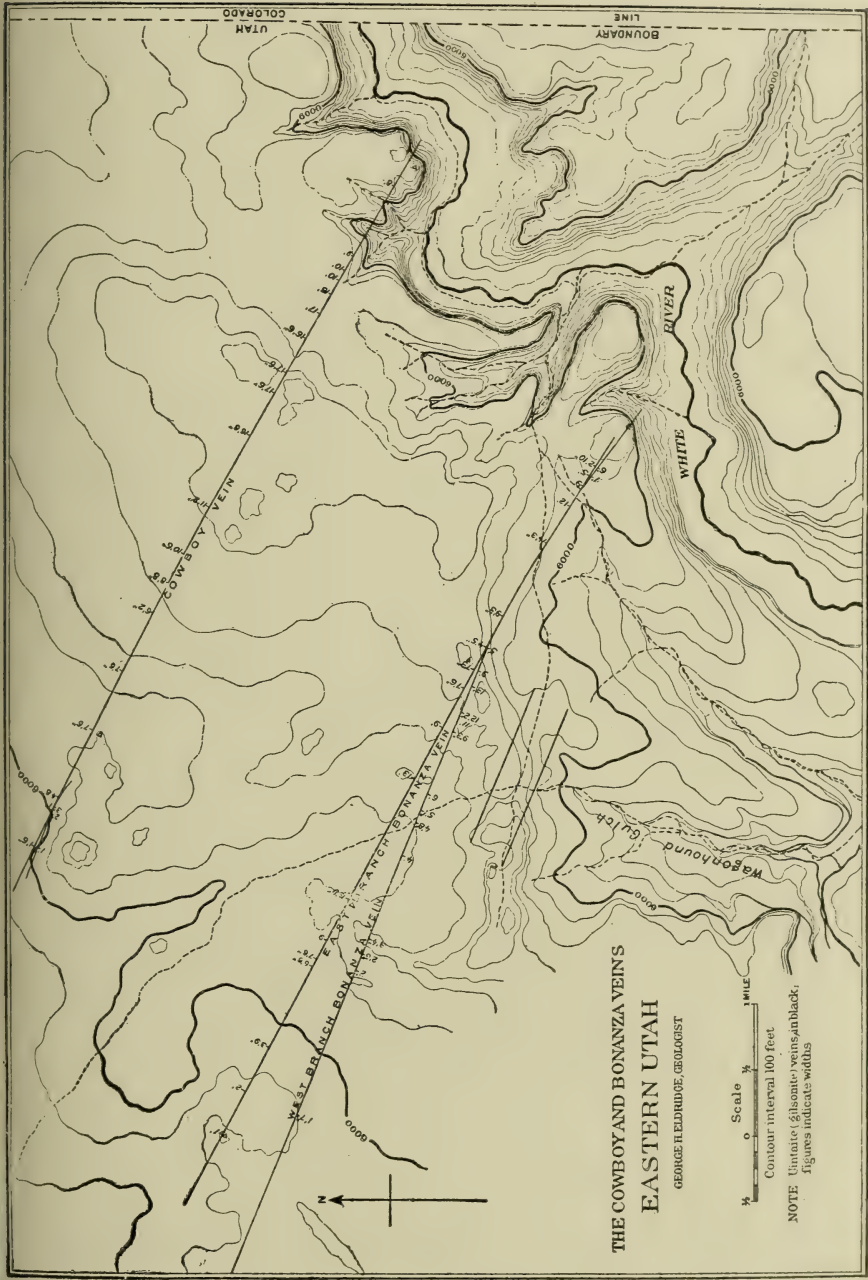
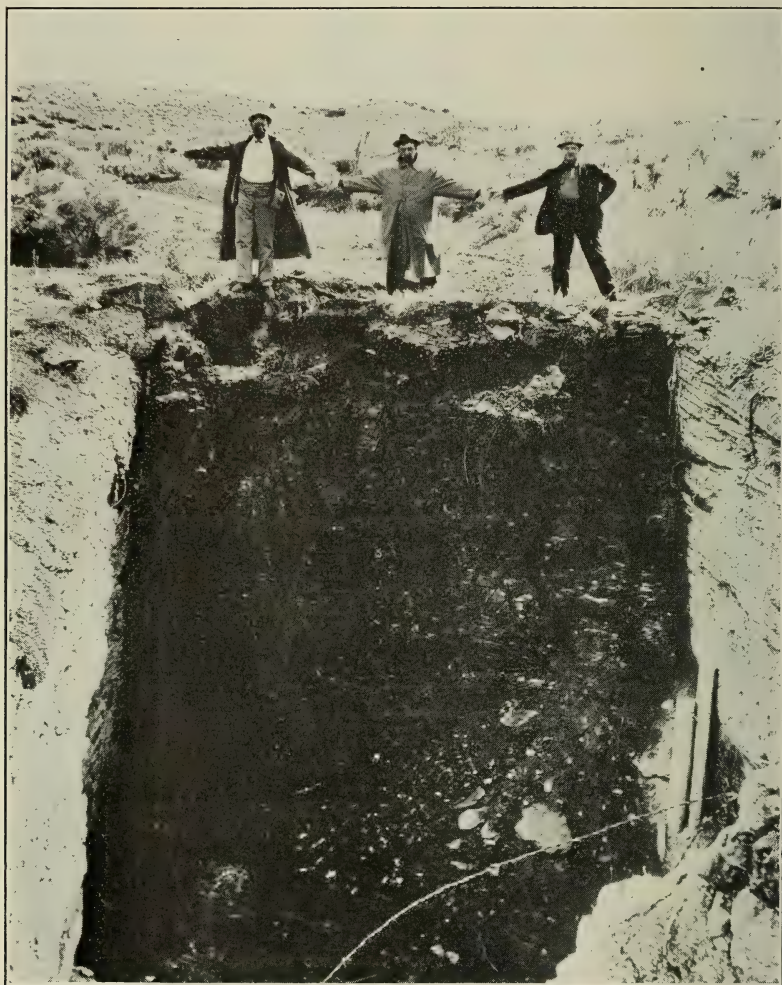

Fig. 47.—Map of Gilsonite Region, Utah.

three veins known as the Cowboy Vein, the East Branch and the West branch respectively of the Bonanza Vein. The last two are joined together near the southern end. These veins occur in sandstone and shale. The



Courtesy of American Asphalt Association.

FIG. 48.—View of Cowboy Gilsonite Mine, Utah.

shale being harder than the sandstone, seems to have offered greater resistance to the intrusion of gilsonite, and the veins are not therefore as wide when they occur in the latter. The disappearance of the veins to the northwest also occurs in shales, and as the gilsonite passes from

sandstone into shale, it splits up into a number of smaller veinlets, which gradually thin into fine hair-like fissures.

The Cowboy is the largest and attains a maximum width of 18 ft., maintaining a width of 8 to 12 ft. for 4 miles. Its total length is 7 to 8 miles. A typical view of the Cowboy Mine is shown in Fig. 48.

The Bonanza Veins have been followed for 7 miles, but they are not as wide as the Cowboy.

A number of smaller veins also occur in this region, including the "Rainbow," "Harrison," "Colorado," etc., which are narrower and shorter than the foregoing.

Black Dragon Vein. This occurs southwest of Evacuation Creek, a tributary of the White River, near the Colorado line. It has been traced for 4 miles, and averages between 2 and 3 ft. wide, the maximum being 8 ft. near the southern end. It is associated with sandstone, limestone and shale. In some places, the rock is impregnated with gilsonite 1 to 3 ft. along side of the vein proper. A branch railroad runs from Dragon, Utah, connecting with the Denver & Rio Grande R. R. at Mack, Colorado, from which point most of the gilsonite is shipped East.

The methods of mining the gilsonite are very crude, and involve the use of a pick and shovel, together with some sort of simple hoisting apparatus. Very little if any timber is required, as the veins are nearly vertical, and the surrounding rock is firm and self-supporting. The gilsonite is shipped in sacks holding about 200 lbs. One man can mine and sack an average of 2 tons per day 10 of hours. Approximately 20,000 tons of gilsonite are mined and shipped from this region each year. It is estimated that 32,000,000 tons of gilsonite are still available in the entire region.

GLANCE PITCH

Glance pitch resembles gilsonite in the external appearance, with the exception of the streak, which is a decided brown in the case of gilsonite, and black in the case of glance pitch. It also differs in having a higher specific gravity and producing a larger percentage of fixed carbon. It always has a brilliant conchoidal fracture, and a fusing-point between 250 and 350 ° F. (K. and S. method). In general, glance pitch complies with the following characteristics:

(Test 1) Color in mass.....	Black
(Test 4) Fracture.....	Conchoidal to hackly
(Test 5) Lustre.....	Bright to fairly bright
(Test 6) Streak on porcelain.....	Black
(Test 7) Specific gravity at 77° F.....	1.10-1.15
(Test 9a) Hardness, Moh's scale.....	2

(Test 9b)	Hardness, needle penetrometer at 77° F.....	0
(Test 9c)	Hardness, consistometer at 77° F.....	90-120
(Test 9d)	Susceptibility factor.....	> 100
(Test 10)	Ductility at 77° F.....	0
(Test 13)	Odor on heating.....	Asphaltic
(Test 14a)	Behavior on melting.....	Forms a comparatively thick and viscous melt
(Test 14b)	Behavior on heating in flame.....	Softens and flows
(Test 15a)	Fusing-point (K. and S. method).....	250-350° F.
(Test 15b)	Fusing-point (Ball and Ring method).....	270-375° F.
(Test 16)	Volatile at 325° F., 7 hrs. (dry substance).....	Less than 2%
	Volatile at 400° F., 7 hrs.....	Less than 4%
(Test 19)	Fixed carbon.....	20-30%
(Test 21a)	Soluble in carbon disulphide.....	Usually greater than 95%
(Test 21b)	Non-mineral matter insoluble.....	Less than 1%
(Test 21c)	Mineral matter.....	Less than 5%
(Test 22)	Carbenes.....	Less than 1.0%
(Test 23)	Soluble in 88° naphtha.....	20-50%
(Test 26)	Carbon.....	80-85%
(Test 27)	Hydrogen.....	7-12%
(Test 28)	Sulphur.....	2- 8%
(Test 29)	Nitrogen and oxygen.....	A trace to 2%
(Test 33)	Paraffine.....	0-Tr. %
(Test 35)	Sulphonation residue.....	80-95%
(Test 37)	Saponifiable matter.....	Tr.
(Test 41)	Diazo reaction.....	No.
(Test 42)	Anthraquinone reaction.....	No.

Glance pitch appears to be intermediate between the native asphalts and grahamite. It is probably derived from a different character of petroleum than gilsonite, having nevertheless reached a parallel stage in its metamorphosis, under approximately the same external conditions.

MEXICO

Chapapote. As stated previously (p. 86), deposits of very pure asphalt occur in this locality, varying from very soft consistency to a hard and brittle asphaltite, properly classified as "glance pitch." They show a lustrous and conchoidal fracture, a black streak, fuse in the neighborhood of 250° F. (K. and S. method), contain over 20 per cent of fixed carbon, and are more than 99 per cent soluble in carbon disulphide.

WEST INDIES

Barbados. Glance pitch was first reported in 1750 by Griffith Hughes, and since 1896 has been mined almost continuously. Deposits occur in a number of localities throughout the island, especially in the Conset district, at Groves, Springfield, St. Margaret, Quinty, and Burnt Hill. This asphaltite has been marketed under the name of "manjak," which was originally applied to the Barbados product, although the name was subsequently associated with a variety of grahamite mined in Trinidad (see p. 146). The deposits were first worked on a commercial scale by Walter Merivale in 1896, who also accurately described the deposit, and the properties of the mineral.

Barbados manjak contains a very small percentage of sulphur (between 0.7 and 0.9 per cent), and about 1-2 per cent of mineral matter. Its specific gravity

at 77° F. is in the neighborhood of 1.10, fusing-point 320–340° F. (K. and S. method), the percentage of fixed carbon as reported by different observers varies between 25 and 30 per cent and its solubility in carbon disulphide 97–98 per cent. Near the surface, the manjak is hard and brittle with a high fusing-point, but at the lower levels of the mines it is found softer, and with a much lower fusing-point, partaking of the nature of an asphalt, rather than an asphaltite, and clearly proving the metamorphosis of one from the other. It also indicates that the manjak originated in the lower strata, having been thrust upward in the form of a dyke (see also Trinidad grahamite, p. 146).

It is used largely for the manufacture of varnishes and japans on account of its high purity, gloss, and intense black color.¹

Santo Domingo (Hayti). A deposit of glance pitch similar to the preceding has been reported near Azua on the Bay of Ocoa. This has not been developed commercially, nor are analyses available.

COLOMBIA, SOUTH AMERICA

Very large deposits of glance pitch occur at Chaparral, in the Province of Tolima, on the Saldaña River, which empties into the Magdalena River. The deposit is about 100 miles southwest of Bogota. It is transported by boats down the Magdalena River to the coast, whence it is exported. About 2000 tons are shipped annually, having a high-fusing point, and over 99 per cent soluble in carbon disulphide.² It is used largely for the manufacture of varnish, and tests as follows:

(Test 4) Fracture.....	Conchoidal
(Test 5) Lustre.....	Bright
(Test 6) Streak.....	Black
(Test 7) Specific gravity at 77° F.....	1.12
(Test 8a) Hardness, Moh's scale.....	2
(Test 8b) Hardness, penetrometer	0
(Test 14b) Heating in flame.....	Softens and burns
(Test 15) Fusing-point (K. and S. method).....	275° F.
(Test 19) Fixed carbon.....	26.45%
(Test 21a) Solubility in carbon disulphide.....	96.0%
(Test 21b) Non-mineral matter insoluble.....	0.7%
(Test 21c) Mineral matter.....	3.3%

SYRIA

Hasbaya. This constitutes one of the most important asphaltite deposits in the region. It is located about 40 miles southeast of Beirut, and west of Mt. Hamon. It has a bright, black lustre, and a black streak. It contains from a trace to about 5 per cent mineral matter, and fuses at 275° F. It shows 27.0 per cent fixed carbon, and on analysis: carbon, 77.18 per cent; hydrogen, 9.07 per cent; sulphur, 0.40 per cent; nitrogen, 2.10 per cent; and mineral matter, 0.50 per cent. The deposit has been worked extensively, and a number of years ago fairly large quantities were exported to the United States for the manufacture of varnishes.

Dead Sea. This deposit is merely of historical interest, as it constituted one of the most important sources of supply for the ancients (p. 5). There appear

¹ Merivale, *Trans. Fed. Inst. Eng.*, **14**, 539, 1896; also **16**, 33, 1898; Bedson, *Trans. Am. Inst. Mining Eng.*, **16**, 388, 1899; Emtage, *J. Royal Soc. Arts*, **52**, 367, 1904; Garrett, *J. Soc. Chem. Ind.*, **31**, 314, 1912.

² *J. Soc. Chem. Ind.*, **23**, 278, 1904.

to be large veins of asphalt at the bottom of the Dead Sea, the water of which is saturated with salt (25 per cent in solution) having a gravity of about 1.21. The asphalt has a specific gravity at 77° F. of 1.104, and as masses become detached at the bottom by earthquake shocks or otherwise, they float to the surface, where they are gathered up by natives. A section through the Dead Sea showing the veins of asphalt is illustrated in Fig. 49. This glance pitch shows a lustrous

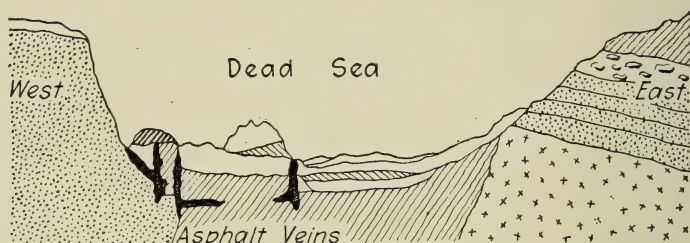

FIG. 49.—Vertical Section through Dead Sea Showing Glance Pitch Veins.

conchoidal fracture, and a black streak. Its fusing-point is 275° F., over 99 per cent is soluble in carbon disulphide, and it yields 20 per cent of fixed carbon. The supply is limited and the material is used only to a small extent locally.¹

EGYPT

A deposit of Glance Pitch has been reported in the Arabian Desert between the Nile and the Red Sea in the neighborhood of Neapolis. It has a specific gravity of 1.10 at 77° F., a conchoidal lustrous fracture, a black streak, fuses at 265° F., and contains over 99 per cent soluble in carbon disulphide.

GRAHAMITE

This asphaltite varies considerably in composition and physical properties, some deposits occurring fairly pure and others are associated with considerable mineral matter, running as high as 50 per cent.² In general, however, it complies with the following:

(Test 1)	Color in mass.....	Black
(Test 4)	Fracture.....	Conchoidal to hackly
(Test 5)	Lustre.....	Very bright to dull
(Test 6)	Streak on porcelain.....	Black
(Test 7)	Specific gravity at 77° F.:	
	Pure varieties (containing less than 10% mineral matter).....	1.15 -1.20
	Impure varieties (containing more than 10% mineral matter).....	1.175-1.50

¹ *J. Roy. Soc. Arts*, **56**, 829, 1908.

² "Grahamite, A Solid Native Bitumen," by Clifford Richardson, *J. Chem. Soc.*, **32**, 1032, 1910; "Gilsonite and Grahamite; the Result of the Metamorphism of Petroleum under a Particular Environment," by Clifford Richardson, *J. Ind. Eng. Chem.*, **8**, 493, 1916.

(Test 9a) Hardness, Moh's scale.....	2-3
(Test 9b) Hardness, needle penetrometer at 77° F.....	0
(Test 9c) Hardness, consistometer at 77° F.....	Over 150
(Test 9d) Susceptibility factor.....	> 100
(Test 14b) Behavior on heating in flame:	
Variety showing a conchoidal fracture and a black lustre.....	Decrepitates violently
Variety showing a hackly fracture and a fairly bright to dull lustre.....	Softens, splits and burns
(Test 15a) Fusing-point (K. and S. method).....	350-600° F.
(Test 15b) Fusing-point (Ball and Ring method).....	370-625° F.
(Test 16) Volatile at 500° F., 4 hrs.....	Less than 1%
(Test 19) Fixed carbon.....	30-55%
(Test 21a) Soluble in carbon disulphide.....	45-100%
(Test 21b) Non-mineral matter insoluble in carbon disulphide..	Less than 5%
(Test 21c) Mineral matter.....	Variable (up to 50%)
(Test 22) Carbenes.....	0-80%
(Test 23) Soluble in 88° petroleum naphtha.....	Tr.-50%
(Test 30) Oxygen in non-mineral matter.....	0-2%
(Test 33) Paraffine.....	0-Tr.%
(Test 35) Sulphonation residue.....	80-95%
(Test 37) Saponifiable matter.....	Tr.
(Test 41) Diazo reaction.....	No.
(Test 42) Anthraquinone reaction.....	No.

In general, grahamite is characterized by the following features:

- (1) High specific gravity;
- (2) Black streak;
- (3) High fusing-point;
- (4) High percentage of fixed carbon;
- (5) Solubility of non-mineral matter in carbon disulphide.

The individual deposits of grahamite occur in the following localities:

UNITED STATES

West Virginia

Ritchie County. The original deposit of grahamite was discovered in West Virginia.¹ It was first described by Prof. J. P. Leslie in a paper read before the American Philosophical Society, March 20, 1863. It is found in but a single locality in Ritchie County, about 25 miles southeast of Parkersburg. The grahamite fills an almost vertical fissure in sandstone, a mile long, varying in width from 2 ins. at the ends to 4 and 5 ft. in the centre. Its depth is assumed to be 1500 to 1600 ft.

The mine has been long abandoned, as the available supply of grahamite is exhausted. Fig. 50 shows a view of the opening in the hillside from which the grahamite has been removed. Fig. 51 shows the nature and extent of the workings. Next to the sandstone walls, the grahamite shows a coarsely granular structure, with a semi-dull fracture. The following layer is highly columnar in structure with a lustrous fracture. Finally in the centre of the vein, the grahamite

¹J. P. Leslie, *Proc. Am. Phil. Soc.*, **2**, 1863; Prof. Henry Wurtz, *Proc. Amer. Soc. for the Adv. of Science*, **18**, 124, 1869; "Uintaite, Albertite, Grahamite, and Asphaltum Described and Compared, with Observations on Bitumen and its Compounds," by W. P. Blake, *Trans. Am. Inst. Mining Eng.*, **18**, 563-82, 1889; W. M. Fontaine, *Am. J. Sci.*, **6**, October 14, 1873, Second Series; I. C. White, *Bull. Geological Soc. Am.*, **10**, 277, 1899.

is more compact and massive, with the columnar structure less developed and a semi-dull fracture. This variation in structure, fracture and lustre is characteristic of grahamite deposits.

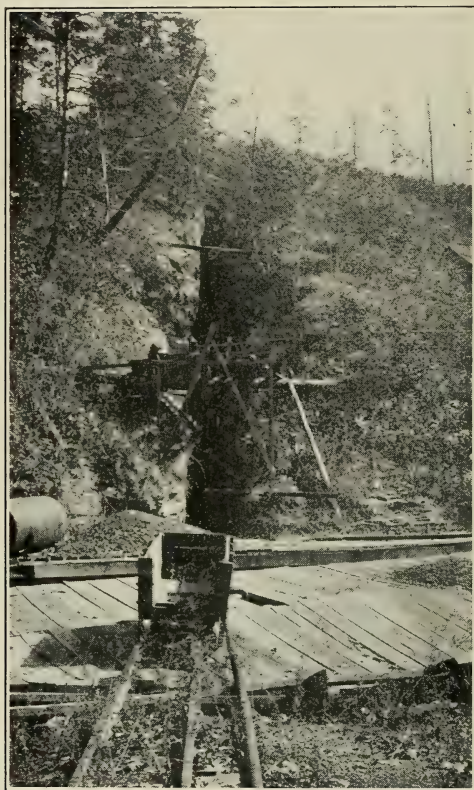

FIG. 50.—View of Grahamite Vein, Ritchie County, West Virginia.

On analysis it tests as follows:

(Test 6) Streak on porcelain.....	Black
(Test 7) Specific gravity at 77° F.....	1.18-1.185
(Test 9a) Hardness on Moh's scale.....	2
(Test 14b) Behavior on heating in flame.....	Softens, burns and splits
(Test 15a) Fusing-point (K. and S. method).....	520-540° F.
(Test 19) Fixed carbon.....	42.15 and 42.48%
(Test 21a) Soluble in carbon disulphide:	
Non-mineral matter.....	97.61%
Combined mineral matter.....	0.44%
(Test 21b) Non-mineral matter insoluble.....	0.17%
(Test 21c) Free mineral matter.....	1.71%
Total.....	99.93%

(Test 22)	Insoluble in carbon tetrachloride.....	55.0%
(Test 23)	Soluble in 88° naphtha.....	3.0%
(Test 25)	Hydroscopic moisture.....	0.07%
(Test 26)	Carbon.....	86.56%
(Test 27)	Hydrogen.....	8.68%
(Test 28)	Sulphur.....	1.79%
	Difference.....	2.97%

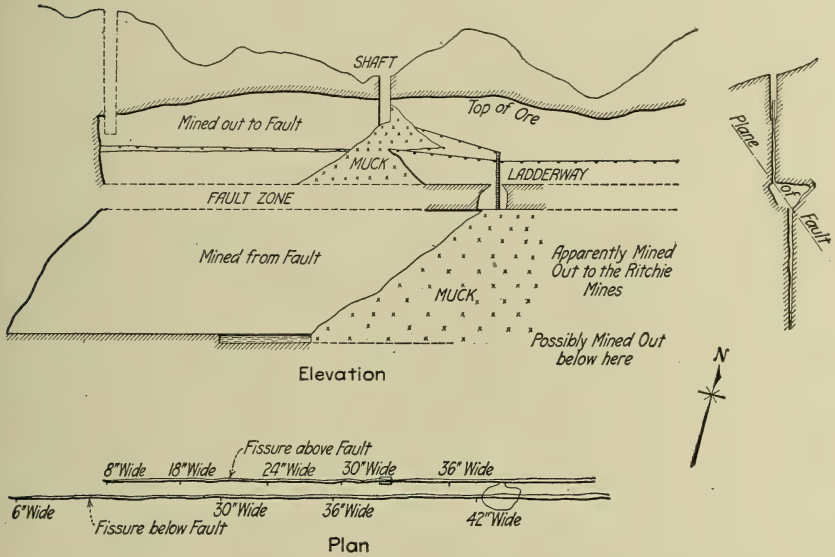

FIG. 51.—Sections through Grahamite Mine, Ritchie County, W. Va.

Texas

Fayette and Webb Counties. Richardson¹ reports a deposit of grahamite in Fayette County in the neighborhood of Lagrange, also an occurrence in Webb County, near Laredo, in the southern portion of the State. These test as follows:

	Fayette County Grahamite. Per Cent.	Webb County Grahamite. Per Cent.
(Test 19) Fixed carbon.....	37.7	52.8
(Test 21c) Mineral matter.....	4.2	2.9
(Test 25) Moisture.....	0.3	0.3
(Test 26) Carbon.....	76.2	78.6
(Test 27) Hydrogen.....	6.6	7.5
(Test 28) Sulphur.....	7.4	5.4
(Test 29) Nitrogen.....	0.4	1.2
Undetermined.....	5.2	5.1

¹ *J. Am. Chem. Soc.* **32**, 1032, 1910.

Oklahoma¹

Pushmataha County. Two small occurrences are reported in the Potato Hills about 5 miles north of Tuskahoma. One is in SE $\frac{1}{4}$, Sec. 1, T 2 N, R 19 E, and the other in NE $\frac{1}{4}$, Sec. 2, T 2 N, R 19 E. Neither of these is of importance.

Jackfork Creek Deposit. The largest known grahamite vein in the world occurs in Jackfork Valley, 12 miles west of Tuskahoma in the SE $\frac{1}{4}$, NE $\frac{1}{4}$, Sec 9, T 2 N, R 18 E. It is about 1 mile long, and varies in thickness from 19 to a maximum of 25 feet. At the surface the vein dips at an angle of 37°, and after continuing downward for 140 feet, turns suddenly to an angle between 45 and 50°. It is illustrated in Fig. 52. The grahamite fills a fault in shaly sandstone. The upper wall

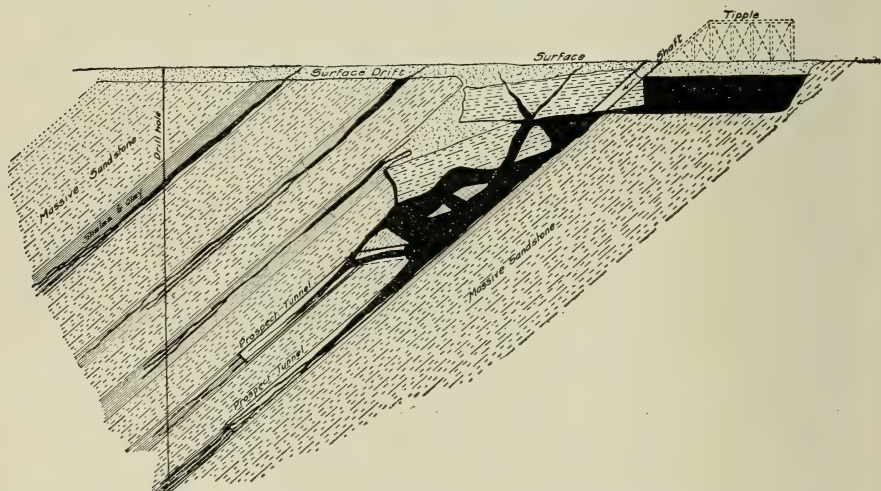

Courtesy of Central Commercial Co.

FIG. 52.—Vertical Section through Grahamite Mine Near Tuskahoma, Okla.

of the vein is firm and requires no timbering. In mining the material, cave-ins are prevented by allowing pillars of grahamite to remain in place to support the upper "hanging" rock wall. When the author visited the mine in 1912, a track was laid along the bottom wall, and the grahamite hoisted out in skips on a cable-way. There is evidence of large pieces of rock having become detached from the hanging wall and fallen into the deposit of grahamite before it became solid.

As is common with most grahamite deposits, several distinct types of material are found in the vein. The grahamite which occurs along the rock walls for a thickness of 2 to 6 ft. shows a hackly (known as a "pencil-

¹ "Grahamite Deposits of Southeastern Oklahoma," by J. A. Taff, Contributions to Economic Geology; Bull. 380, U. S. Geol. Survey, p. 286, 1908; "Asphalt and Petroleum in Oklahoma," by L. L. Hutchison, Bull. 2, Okla. Geol. Survey, Guthrie, 1911.

lated") fracture, and a semi-dull to dull lustre, whereas the grahamite taken from the centre of the vein shows a conchoidal fracture and very bright lustre similar to gilsonite. This is probably due to the fact that the grahamite in contact with the wall cooled more rapidly than the central portion, and very likely has also been subjected to more or less strain from movements of the surrounding rock. Many thousand tons of grahamite have been mined from this vein which is now pretty nearly exhausted (from 6000 to 7000 carloads during the first four years, of its operation, and at the time of the author's visit about 50 tons per day) The cost of a moving to the surface is comparatively small (80c. to \$1.00 per ton), but the material has to be carted 10 miles to Tuskahoma, the nearest shipping point (costing about \$2.50 per ton).

On analysis it tests as follows:

(Test 1)	Color in mass.....	Black
(Test 4)	Fracture (a).....	Conchoidal
	Fracture (b).....	Hackly
(Test 5)	Lustre (a).....	Bright
	Lustre (b).....	Semi-bright to dull
(Test 6)	Streak (a and b).....	Black
(Test 7)	Specific gravity at 77° F. (a and b).....	1.18-1.195
(Test 9a)	Hardness, Moh's scale.....	2
(Test 14b)	Behavior on heating in flame (a).....	Intumesces violently
	Behavior on heating in flame (b).....	Softens, splits and burns
(Test 15a)	Fusing-point (K. and S. method) (a and b).....	530-604° F.

NOTE. There is no appreciable difference in fusing-point between the two varieties (a and b).

(Test 16)	Volatile matter 500°, 4 hrs.....	Less than 1%
(Test 19)	Fixed carbon (a and b).....	52.76-55.00%
(Test 21a)	Solubility in carbon disulphide.....	Greater than 99.5%
(Test 21b)	Non-mineral matter insoluble.....	Less than 0.5%
(Test 21c)	Free mineral matter (a and b).....	0.21-0.70%

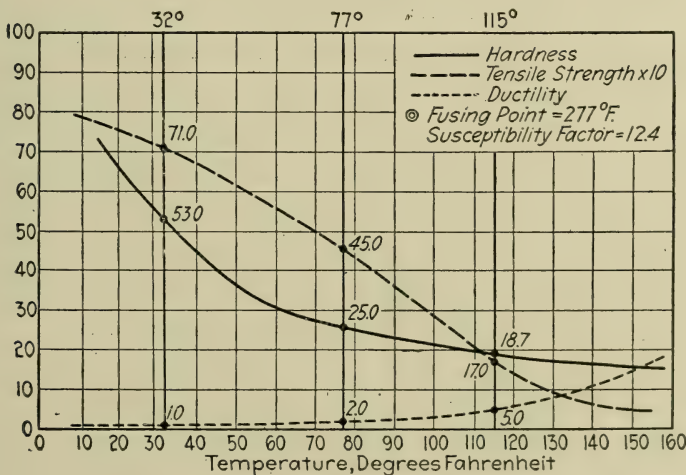

Fig. 53.—Chart of Physical Characteristics of Fluxed Oklahoma Grahamite Mixture.

Fig. 53 shows the hardness, tensile strength (multiplied by 10) and ductility curves of a mixture of the grahamite and residual oil, fluxed together so as to have a hardness of exactly 25.0 at 77° F. The mixture contains: grahamite, 60 per cent; and residual oil, 40 per cent. The resulting fusing-point (K. and S. method) was 277° F. The same residual oil was used in this test as for the gilsonite in Fig. 54, and the fusing-point of the grahamite used was 550° F. (K. and S. method.).¹

Impson Valley Deposit. This occurs on a branch of the Tenmile Creek on the SW $\frac{1}{4}$ Sec. 21 and NW $\frac{1}{4}$, Sec. 28, T 1 S., R 14 E., about 16 miles northwest of Antlers. It is known under various names such as Jumbo Mine, Choctaw Mine, or Old Slope Mine. This is the second largest deposit in the State of Oklahoma.

It occurs in a zone of faulting and fracture in shale rock, and the vein is lenticular in form, occurring as a series of pockets of the general form, illustrated in Fig. 21, varying in thickness from a fraction of an inch to 30 ft. as a maximum. As the dip of the vein is very steep, the material must be hoisted out in buckets with a windlass, and then hauled 15 miles to Moyer, the nearest shipping point, at a cost of about \$3.00 per ton. Heavy timbering is necessary on account of the character of the enclosing rock. The grahamite shows the same variation in fracture and lustre as the Jackford Creek deposit. On analysis it tests as follows:

Color in mass, fracture, lustre, specific gravity, hardness and behavior on heating in flame, same as the preceding:

(Test 15) Fusing-point (K. and S. method).....	460-520° F.
(Test 16) Volatile matter, 500° F., 4 hrs.....	Less than 1%
(Test 19) Fixed carbon.....	48.5 -53.0%
(Test 21a) Solubility in carbon disulphide.....	90.5 -96.2%
(Test 21b) Non-mineral matter insoluble.....	0.0- 6.0%
(Test 21c) Free mineral matter.....	1.1 - 6.7%
(Test 22) Carbenes.....	68%
(Test 23) Solubility in 88° naphtha.....	0.2 - 0.7%
(Test 25) Moisture at 100° C.....	0.0 - 0.7%
(Test 26) Carbon.....	83.90%
(Test 27) Hydrogen.....	7.14%
(Test 28) Sulphur.....	1.04- 2.24%
Undetermined.....	6.72%
(Test 33) Saturated hydrocarbons.....	0.32%

Atoka County. McGee Creek Deposits. Two small veins, one 4 in. and another about 1 ft. in thickness, occur in the SW $\frac{1}{4}$, Sec. 23, T 1 N, R 14 E, about 15 miles northwest of Antlers. These constitute the so-called "William's Mine." Shafts have been sunk from 15 to 20 feet, but not sufficient grahamite has been found to warrant continuing operations. It tests as follows:

(Test 19) Fixed carbon.....	43.5-45.7%
(Test 21a) Soluble in carbon disulphide.....	95.7-99.7%
(Test 21b) Non-mineral matter insoluble.....	0.0- 4.0%
(Test 21c) Free mineral matter.....	0.3%
(Test 23) Soluble in 88° naphtha.....	4.5- 6.8%

A larger deposit also occurs in the vicinity of McGee Creek, in the NE $\frac{1}{4}$, Sec. 25, T 1 S, R 13 E, and NW $\frac{1}{4}$, Sec. 30, T 1 S, R 14 E, about 12 miles

¹ Further data on the fusing-points and hardness at various temperatures of mixtures of the grahamite with a Mexican residuum will be found in *J. Ind. Eng. Chem.*, 7, 205, 1915, "Variations of the Physical Characteristics of a Petroleum Residuum with Increasing Percentages of grahamite," by H. Rossbacher.

southeast of Stringtown. This is known as the Pumroy or Moulton Mine. The grahamite fills a fissure, caused by faulting, and is reported to be 14 to 15 ft. thick at the surface, tapering to about 4 ft. at a depth of 110 ft. The mine is now abandoned, but when operated some years ago, about 2000 tons were mined annually, being hauled 15 miles to Stringtown, the nearest shipping point. A prospect occurs about $\frac{1}{4}$ mile south of the foregoing, consisting of a vein about 2 ft. thick. On analysis it tests as follows:

(Test 15a) Fusing-point (K. and S. method).....	473° F.
(Test 19) Fixed carbon.....	38.42-41.0%
(Test 21) Solubility in carbon disulphide.....	83.7 -95.0%
(Test 21b) Non-mineral matter insoluble.....	4.8 - 9.2%
(Test 21c) Free mineral matter.....	0.98- 7.1%

Boggy Creek Deposit. This occurs about 6 miles northeast of Atoka, and 1 mile from the M. K. & T. R. R. in the SW $\frac{1}{4}$, Sec. 29, T 1 S, R 12 E. The vein occurs in shale varying in thickness from several inches to several feet. It has long been abandoned, and no analyses are available.

Chickasaw Creek Deposit. An undeveloped vein in shale, carrying streaks of grahamite, about 9 ft. thick has been reported in Sec. 15, T 1 S, R 12 E about $2\frac{1}{2}$ miles east of Stringtown on the M. K. & T. Railroad.

Stephens County. This occurs in the NW $\frac{1}{4}$, Sec. 6, T 2 S, R 4 W, about 6 miles north of Loco, and 18 miles east of Comanche. This vein has been prospected for about half a mile, and occurs as a fault in sandstone and shale. The vein is of a pronounced lenticular type existing in a series of pockets, some as large as 10 ft. across, often connected with a thin vein-like crack less than an inch wide. At several points the deposit pinches out entirely. In the direction of the vein, the pockets measure 25 to 100 ft. horizontally and vertically. A characteristic feature of this deposit is the infiltration of pyrites, grains of which are clearly visible to the naked eye. The surrounding shale is porous, and carries minute particles of the grahamite, which are disseminated throughout the rock for some distance on both sides of the vein.¹

The material tests as follows:

(Test 4) Fracture.....	Hackly
(Test 5) Lustre.....	Dull
(Test 6) Streak.....	Black
(Test 15a) Fusing-point (K. and S. method).....	401-466° F.
(Test 19) Fixed carbon.....	34.4 -39.4%
(Test 21a) Soluble in carbon disulphide.....	81.85-97.70%
(Test 21b) Non-mineral matter insoluble.....	0.10- 3.60%
(Test 21c) Free mineral matter (mostly pyrites).....	2.20-14.55%

Colorado

Grand County. Deposits of grahamite are found in Middle Park along the continental divide in the northern part of Grand County. A large vein occurs in Sec. 24, T 4 N, R 77 W, on a fork of Willow Creek about 25 miles north of Grand River, in a region of clay, conglomerate and sandstone. Several veins and fissures have been prospected, the main vein varying in width from 2 ins. up to 6 ft., and extending 100 to 125 ft. Comparatively small quantities of the gra-

¹ W. R. Crane, *Mines and Minerals*, Jan., 1906.

hamite have been mined, due to difficulties in transportation to the nearest railroad. The product tests:

(Test 7)	Specific gravity at 77° F.....	1.15- 1.16
(Test 19)	Fixed carbon.....	47.4 -49.3%
(Test 21a)	Soluble in carbon disulphide.....	98.2 -99.3%
(Test 21b)	Non-mineral matter insoluble.....	0.6 - 1.7%
(Test 21c)	Free mineral matter.....	0.0 - 0.1%
(Test 22)	Carbenes.....	80.6%
(Test 23)	Solubility in 88° naphtha.....	0.8 - 1.3%
(Test 26)	Carbon.....	85.9 -86.1%
(Test 27)	Hydrogen.....	7.63- 7.75%
(Test 28)	Sulphur.....	0.93- 0.99%
	Undetermined.....	5.34- 5.45%

MEXICO

Province of Vera Cruz. A vein of grahamite has been found at Huasteca on the Panuco River¹ in a vertical fissure, occurring in shales with an overflow at the junction of the shale stratum with the overlying sandstone. On analysis the material tests as follows:

(Test 7)	Specific gravity, at 77° F.....	1.145
(Test 19)	Fixed carbon.....	35.3%
(Test 21a)	Soluble in carbon disulphide.....	93.8%
(Test 21b)	Non-mineral matter insoluble.....	3.4%
(Test 21c)	Free mineral matter.....	2.8%
(Test 23)	Solubility in 88° naphtha.....	8.4%

Province of Tamaulipas. Another deposit has been reported near the City of Victoria, containing 3.4 per cent of non-mineral matter insoluble in carbon disulphide and 54 per cent of fixed carbon.

CUBA²

Province Pinar del Rio. In the District of Mariel, near the City of Bahia Honda, there occurs a fairly large vein of grahamite, known as the "La America Mine," or the "Rodas Conception Mine," testing as follows:

(Test 4)	Fracture.....	Shows distinct cleavage veins
(Test 5)	Lustre.....	Semi-dull
(Test 7)	Specific gravity, at 77° F.....	1.157
(Test 19)	Fixed carbon.....	40.0-42.2%
(Test 21a)	Soluble in carbon disulphide.....	99.4-99.6%
(Test 21b)	Non-mineral matter insoluble.....	0.0- 0.1%
(Test 21c)	Free mineral matter.....	0.4- 0.5%
(Test 22)	Carbenes.....	About 25%

Another deposit occurs near the City of Mariel, 1 mile south of Mariel Bay, known as the "Magdalena Mine," which extends about 100 ft. in length and 40 ft. in width. Large quantities of asphalt have been mined from this deposit, which

¹ *Am. J. Sci.*, **12**, 277, 1876.

² "Bitumen in Cuba," by T. Wayland Vaughan, *Eng. Mining J.*, **73**, 344, 1902; "An Examination of Some Bituminous Minerals," by F. C. Garrett, *J. Soc. Chem. Ind.*, **21**, 314, 1912.

is characterized by the presence of about 40 per cent of associated mineral matter. It tests:

(Test 4) Fracture.....	Conchoidal
(Test 5) Lustre.....	Dull
(Test 6) Streak on porcelain.....	Black
(Test 7) Specific gravity, at 77° F.....	1.41 -1.46
(Test 19) Fixed carbon.....	30.0 -38.0%
(Test 21a) Soluble in carbon disulphide.....	55 -58%
(Test 21b) Non-mineral matter insoluble.....	3 - 5%
(Test 21c) Free mineral matter.....	38 -41%
(Test 22) Carbenes.....	1.5 - 6.3%
(Test 23) Solubility in 88° naphtha.....	37 -48%
(Test 26) Carbon.....	72.5 -77.8%
(Test 27) Hydrogen.....	8.5 - 8.7%
(Test 28) Sulphur.....	6.9 - 7.7%
Difference.....	6.6 -11.4%

Another vein occurs in this same locality, probably a continuation of the preceding, known as the "Mercedes Mine," testing similarly.

Province of Havana. In the neighborhood of Campo Florida, grahamite has been obtained from a mine known as "La Havana," which tests:

(Test 4) Fracture.....	Semi-conchoidal
(Test 5) Lustre.....	Dull
(Test 6) Streak on porcelain.....	Black
(Test 7) Specific gravity at 77° F.....	1.175
(Test 19) Fixed carbon.....	45.0%
(Test 21a) Soluble in carbon disulphide.....	98.9%
(Test 21b) Non-mineral matter insoluble.....	0.7%
(Test 21c) Free mineral matter.....	0.4%
(Test 23) Solubility in 88° naphtha.....	6.0%
(Test 26) Carbon.....	82.5%
(Test 27) Hydrogen.....	7.5%
(Test 28) Sulphur.....	6.4%
Undetermined.....	3.6%

A similar deposit has been reported about 12 miles east of Havana and another one, known as the "Casitalidad Mine," situated about 9-10 miles east of Havana, and 2 miles south of the coast, in a vein 600-900 ft. long and 1-30 ft. thick testing substantially the same as the preceding.

Province of Santa Clara. Nine miles northeast of the City of Santa Clara near Loma Cruz, there occurs the deposit known as "Santa Eloisa," in a bed of serpentine. It tests as follows:

(Test 4) Fracture.....	Semi-conchoidal
(Test 5) Lustre.....	Bright
(Test 6) Streak.....	Black
(Test 7) Specific gravity at 77° F.....	1.29
(Test 19) Fixed carbon.....	34-35%
(Test 21a) Soluble in carbon disulphide.....	78-79%
(Test 21b) Non-mineral matter insoluble.....	1.8 - 2.2%
(Test 21c) Free mineral matter.....	19 -20%
(Test 22) Carbenes.....	2 -3%

Another mine occurs a short distance from Placetas del Sur, in an irregular vein of lenticular form, occurring in several branches. This mine is known as the

"Esperanza," and the product is characterized by its comparatively low fusing-point. The average material as mined tests as follows:

(Test 4) Fracture.....	Hackly
(Test 5) Lustre.....	Moderately bright
(Test 6) Streak.....	Black
(Test 7) Specific gravity, at 77° F.....	1.22
(Test 9a) Hardness, Moh's scale.....	2
(Test 14b) In flame.....	Softens, splits and burns
(Test 15a) Fusing-point (K. and S. method).....	400-433° F.
(Test 19) Fixed carbon.....	50.95%
(Test 21a) Soluble in carbon disulphide.....	97.9-98.8%
(Test 21b) Non-mineral matter insoluble.....	0.05- 0.92%
(Test 21c) Free mineral matter.....	1.15- 2.75%
(Test 36b) Mineral matter combined with non-mineral constituents.....	0.37%

TRINIDAD

Two deposits of grahamite¹ occur near San Fernando on the west coast of the island on the shore of the Gulf of Paria, known as the Vistabella and Marbella Mines. The grahamite has been marketed under the name of "manjak," presumably taking advantage of the popularity of the Barbados glance pitch, although from a geological standpoint the two minerals are entirely different. The veins occur in soft shale and sandstone, in a region carrying petroleum in considerable quantities.

A number of veins of grahamite have been uncovered, the largest known as the Vistabella mine, which measures 360 ft. horizontally and has been mined to a depth of about 250 ft. Its thickness is 11 ft. at the outcrop, and increases steadily to 33 ft. at a depth of 200 ft. Three distinct types have been found in the vein, viz.:

(1) An amorphous coaly type which has a hackly fracture, and usually occurs at the margin of the vein. It is dull in lustre and exhibits no regular jointings.

(2) A columnar type, of dull lustre, having a columnar jointing running at right angles to the margins of the vein. The jointing is often very well formed, dividing the material into hexagonal or pentagonal prisms.

(3) A lustrous variety identical in appearance to gilsonite and Barbados glance pitch (manjak). This has a bright lustre, and a conchoidal fracture, being found in the deeper workings of the mine, in the centre of the vein.

There is no chemical difference in the varieties, although it appears that at the centre of the vein at a depth of about 120 ft. the grahamite has a lower fusing-point, closely resembling the Barbados glance pitch, thus serving as a link between the grahamite and the glance pitch, clearly proving that both are derived by metamorphosis from a common source.

A stratum of oil-bearing sandstone is known to exist beneath the grahamite

¹"The San Fernando Manjak Field," Council Paper No. 3, 1905, Council Paper No. 35, 1906, Council Paper No. 130, 1906, by the Government Geologist, Port-of-Spain, Trinidad; "Manjak as Worked at the Vistabella Mine, Trinidad," by J. C. T. Raspas, *Trans. Inst. Mining Eng.*, Newcastle-upon-Tyne, Sept. 7, 1908; "An Examination of Some Bituminous Minerals," by F. C. Garrett, *J. Soc. Chem. Ind.*, 31, 314, 1912.

which appears more than likely to have been derived from an asphaltic petroleum which intruded under pressure through a fault in the shale.

The mining of the grahamite is comparatively simple, but the shafts have to be carefully timbered, and precautions have to be taken to avoid igniting the gases generated in the workings, as these are highly explosive. It is reported that between 2000 and 2500 tons are mined per annum.

On analysis it tests as follows:

(Test 1)	Color in mass.....	Black
(Test 2)	Homogeneity.....	3 distinct types recognizable (see above)
(Test 4)	Fracture.....	Types 1 and 2, hackly; Type 3 conchoidal.
(Test 5)	Lustre.....	Types 1 and 2 dull; Type 3 bright
(Test 6)	Streak.....	Black
(Test 7)	Specific gravity, at 77° F.....	1.170-1.175
(Test 9a)	Hardness, Moh's scale.....	2
(Test 9b)	Hardness, penetrometer.....	0
(Test 14b)	On heating in flame.....	Softens, splits and burns
(Test 15a)	Fusing-point (K. and S. method).....	350-438° F.

NOTE. The material resembling glance pitch obtained from the centre of the vein at the 200-ft. level fused at 280° F. (K. and S. method).

(Test 15b)	Fusing-point (B. and R. method).....	370-460° F.
(Test 19)	Fixed carbon.....	31.5-35.0%
(Test 20)	Distillation test:	
	Below 150° C.....	0.5%
	150-300° C.....	26.5%
	Above 300° C.....	18.0%
	Carbonaceous residue.....	55.0%
	Total.....	100.0%
(Test 21a)	Solubility in carbon disulphide.....	91.7-96.0%
(Test 21b)	Non-mineral matter insoluble.....	0.9- 1.2%
(Test 21c)	Free mineral matter.....	4.0 - 6.4%, averaging about 5.7%
(Test 22)	Carbenes.....	About 40%
(Test 23)	Solubility in 88° naphtha:	
	At 100-ft. level.....	12.8%
	At 140-ft. level.....	15.2%
	At 200-ft. level.....	18.5%
	At 200-ft. level, softer material in centre.....	56.0%
(Test 25)	Moisture.....	0.2 - 1.0%
(Test 26)	Carbon.....	84.0%
(Test 27)	Hydrogen.....	5.7%
(Test 28)	Sulphur.....	3.0-3.8%
(Test 29)	Nitrogen.....	2.2%
(Test 36b)	Mineral matter combined with non-mineral constituents.....	1.15%

Fig. 54 shows the hardness, tensile strength (multiplied by 10) and ductility curves of a mixture of the grahamite fusing at 400° F. (K. and S. method), and residual oil (the same as utilized in mixture shown in Fig. 53). fluxed together in such proportions that the hardness at 77° F. is exactly 25.0. The

resulting mixture contained grahamite, 32 per cent and residual oil, 68 per cent, and had a fusing-point of 200° F. (K. and S. method).

The Marbella vein is smaller than the Vistabella, attaining a thickness of 7 ft. near its centre. It is lenticular in form and splits up into two smaller veins at one

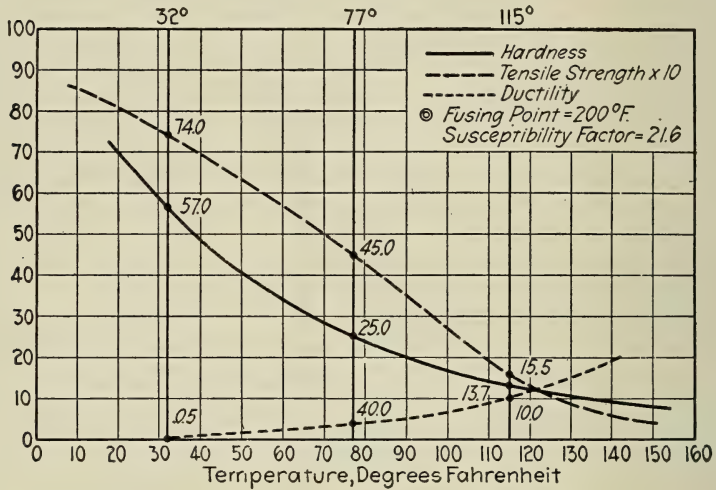

FIG. 54.—Chart of Physical Characteristics of Fluxed Trinidad Grahamite Mixture.

end. The grahamite mined from the Marbella vien has substantially the same characteristics as the preceding. At the 50-foot level 8.8 per cent is soluble in 88° naphtha (Test 23) at the 125-ft. level, 9.6 per cent, and at the 200-ft. level 12 per cent.

CHAPTER XI

ASPHALTIC PYROBITUMENS

THE asphaltic pyrobitumens are natural substances composed of hydrocarbons, characterized by their infusibility and comparative freedom from oxygenated substances. They are grouped into five classes, viz.: elaterite, wurtzilite, albertite, impsonite, and asphaltic pyrobituminous shales. The first four are comparatively free from associated mineral matter (usually under 10 per cent). If the mineral matter predominates, the material is known as an asphaltic pyrobituminous shale, which term is applied indiscriminately to shales containing wurtzilite, albertite or impsonite.

Much confusion exists regarding the classification of asphaltic pyrobitumens. Every now and then it is alleged that some new type is discovered, which on closer investigation proves to be an old substance christened under a different name. Thus the so-called "nigrite" described by E. H. Eldridge,¹ is nothing more than albertite (see p. 155).

Elaterite, wurtzilite, albertite and impsonite when they occur associated with less than 10 per cent of mineral matter, are distinguished from one another as follows:

	Streak.	Specific Gravity at 77° F.	Fixed Carbon, Per Cent.
Elaterite.....	Light Brown	0.90-1.05	2-5
Wurtzilite.....	Light Brown....	1.05-1.07	5-25
Albertite.....	Brown to Black	1.07-1.10	25-50
Impsonite.....	Black	1.10-1.25	50-85

All four are derived from the metamorphosis of petroleum, and it is probable that the impsonite represents the final stage of transformation of elaterite, wurtzilite and albertite, as well as the asphaltites (gilsonite, glance pitch and grahamite).

¹"The Asphalt and Bituminous Rock Deposits of the United States," 22d Annual Report, U. S. Geol. Survey, Wash., D.C. Part I, pp. 222 and 360, 1901.

ELATERITE

This asphaltic pyrobitumen is the prototype of wurtzilite. It is found in a few localities, in small amounts and is of scientific interest only.

ENGLAND

Derbyshire County. Elaterite was originally discovered at the Odin Mine in Castleton by Lister in 1673-4.¹ It was again described by Hatchett,² who found it to be moderately soft and elastic, like India rubber, having a specific gravity of 0.9053-0.988. It is slightly soluble in ether (18 per cent) and swells up in petroleum naphtha. Klaproth³ examined this same material, stating that it "fuses at a *high heat*, and after this may be drawn into threads between the fingers," also that it contains between 6 and 7 per cent of ash.⁴

AUSTRALIA

State of South Australia

Coorong District. A variety of elaterite is found on the coast south of Adelaide, Australia, known under the name of "coorongite."⁵

ASIATIC RUSSIA

Province of Semiryechensk

This deposit occurs at the mouth of the Ili River, in the neighborhood of Lake Balkash,⁶ and tests as follows:

(Test 7) Specific gravity.....	0.995
(Test 21a) Solubility in carbon disulphide.....	Very slight
(Test 21c) Free mineral matter.....	3-5%
(Test 37a) Acid value.....	4.9
(Test 37b) Saponification value.....	56.9
(Test 39) Saponifiable matter.....	11.1
Unsaponifiable matter.....	88.9%

It is characterized by the presence of saponifiable matter, and in this respect differs from the foregoing.

WURTZILITE

This has been found in but one region,⁷ as follows:

UNITED STATES

Utah

Uinta County. This region embraces about 100 square miles in the neighborhood of Indian, Lake, Avintequin and Sams Canyons, trib-

¹ *Phil. Trans.*, 1673.

² *Linn. Trans.*, 4, 146, 1797.

³ *Beitr.*, 3, 107, 1802.

⁴ Morrison, *Min. Mag.*, 8, 133, 1889; and Maguire, *Mines and Minerals*, 20, 398, 1900.

⁵ Jackson, *Pharm. J.*, 31, 763 and 785, 1872; G. C. Morris, *Proc. Acad. Philad.*, 131, 1877; Cumming, *Proc. Royal Soc. Vict.*, 15, 134, 1903; Boodle, *Bull. Roy. Bot. Gardens, Kew*, 145, 1907.

⁶ Rakusin, *Petroleum*, 8, 729, 1913.

⁷ W. P. Blake, *Eng. Mining J.*, 48, 542, 1889; 49, 59, 1890; also 106; *Trans. Am. Inst. Mining Eng.*, 18, 497, 1889.

utaries of Strawberry Creek, which in turn leads into the Uinta River. The veins occur about 50 miles southwest of Fort Duchesne, varying in length from several hundred feet to about 3 miles, and from 1 to 22 in. wide, filling vertical faults in shaly limestone. Altogether about 30 veins have been discovered, closely resembling those of gilsonite. Many of them split into a number of smaller branches, either in a vertical or horizontal direction. The largest veins occur between the Left-Hand and the Right-Hand forks of Indian Canyon. It has been exploited under various names, including elaterite (improper use of this name), aegerite, aeonite, etc.

A view of one of the veins is shown in Fig. 55; a section through the mine, in Fig. 56; and the tramway for conveying the product from the hillside mine to the valley below, in Fig. 57.

Wurtzilite is characterized by being sectile and cutting like horn or whale-bone. Thin flakes are somewhat elastic, comparable in a way to that of glass or mica, rather than to the yielding elasticity of rubber. If a shaving is bent too far or suddenly, it snaps off like glass. This distinguishes it from other asphaltic pyrobitumens as well as the asphaltites.

Attempts were made to find its fusing-point by heating it as high as 800° F. in sulphur, but without having any effect.

It tests as follows:

(Test 1)	Color in mass.....	Black
(Test 4)	Fracture.....	Conchoidal
(Test 5)	Lustre.....	Bright
(Test 6)	Streak.....	Light brown
	Extremely thin splinters are semi-transparent, showing a deep red color by transmitted light.	
(Test 7)	Specific gravity at 77° F.....	1.05-1.07
(Test 9a)	Hardness, Moh's Scale.....	Between 2 and 3
(Test 9b)	Hardness at 77° F. (penetrometer).....	0
(Test 9c)	Hardness, consistometer, 77° F.....	Over 150
(Test 14b)	On heating in flame.....	Softens and burns quietly

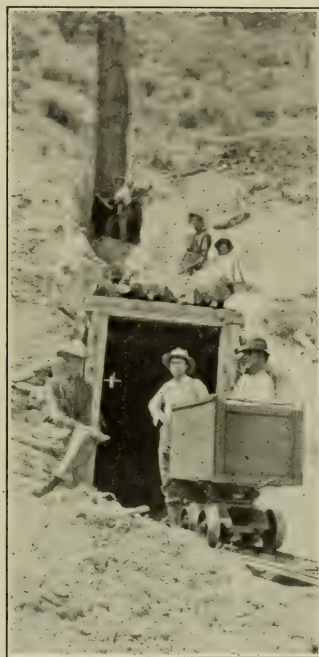

Courtesy of Raven Mining Co.
 FIG. 55.—View of Wurtzilite Mine,
 Uinta County, Utah.

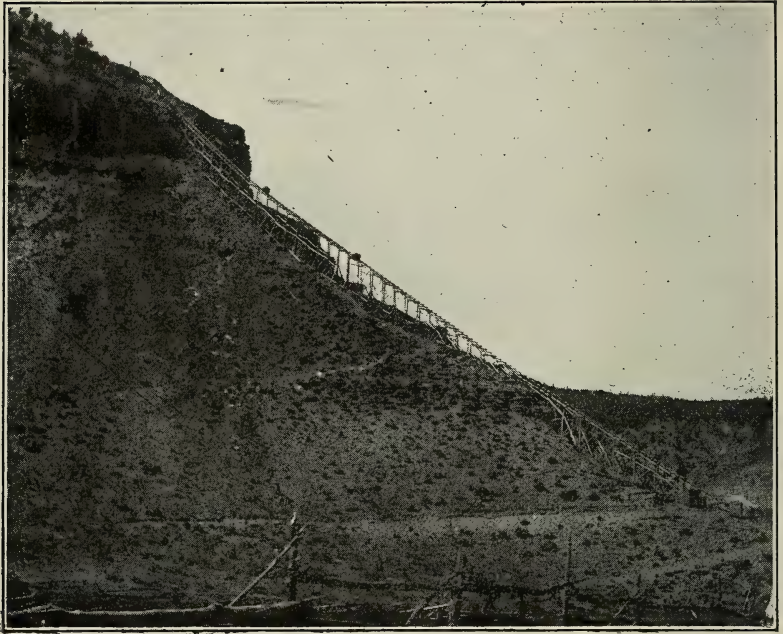

Courtesy of Raven Mining Co.

FIG. 56.—Transporting Wurtzilite from the Mine.

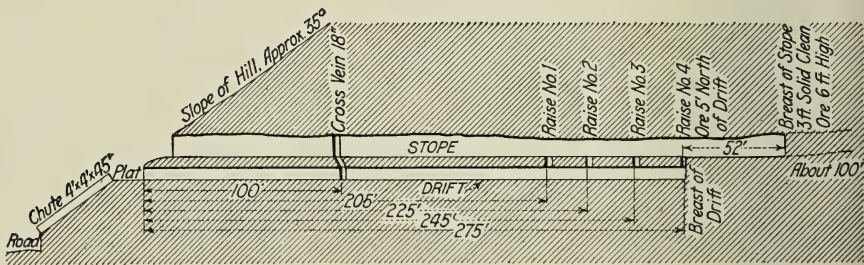

Courtesy of Raven Mining Co.

FIG. 57.—Vertical Section through Wurtzilite Vein, Uinta County, Utah.

(Test 15)	Fusing-point.....	Does not fuse without decom- position
(Test 16)	Volatile at 325° F., in 7 hrs.....	1-3%
(Test 19)	Fixed carbon.....	5-25%
(Test 20)	Distillation test:	
	0-150° C.....	16.15%
	150-200° C.....	21.70%
	200-250° C.....	22.82%
	250-300° C.....	0.91%
	Carbonaceous residue.....	36.92%
(Test 21a)	Soluble in carbon disulphide.....	5 -10%
(Test 21b)	Non-mineral matter insoluble.....	85 -95%
(Test 21c)	Mineral matter.....	0.2- 2.5%
(Test 22)	Carbenes.....	0.0- 1.5%
(Test 23)	Soluble in 88° naphtha.....	0- 2%
(Test 24)	Grams soluble in 100 grams cold solvent:	
	Amyl acetate.....	Insoluble
	Amyl alcohol.....	Insoluble
	Amyl nitrate.....	Insoluble
	Aniline.....	Insoluble
	Benzol.....	Insoluble
	Carbon tetrachloride.....	1.8
	Chloroform.....	1
	Ethyl acetate.....	Insoluble
	Ethyl alcohol.....	Insoluble
	Ethyl ether.....	Insoluble
	Naphtha 62°.....	2.8
	Nitrobenzine.....	Insoluble
	Propyl alcohol.....	Insoluble
	Toluol.....	0.1
	Turpentine.....	45
(Test 26)	Carbon.....	79.5-80.0%
(Test 27)	Hydrogen.....	10.5-12.5%
(Test 28)	Sulphur.....	4.0- 6.0%
(Test 29)	Nitrogen.....	1.8- 2.2%

ALBERTITE

This is a generic term applied to a group of asphaltic pyrobitumens similar to the type-substance which was formerly mined in Albert County, New Brunswick, Canada, characterized by its:

- (1) Infusibility;
- (2) Insolubility in carbon disulphide, etc.;
- (3) Specific gravity (1.07 to 1.10 at 77° F.);
- (4) Percentage of fixed carbon (25 to 50 per cent);
- (5) Small percentage of oxygen present (less than 3 per cent).

It occurs in several localities, of which the typical deposit will be described first.

CANADA

Province of New Brunswick

County of Albert. In 1849 a local geologist, Dr. A. Gesner, discovered a substance originally termed "albert coal," subsequently renamed

"albertite,"¹ on Frederick Brook, a branch of Weldon Creek, near Albert Mines, 20 miles south of Moncton. Shortly after this, litigation gave rise to a discussion whether or not the mineral was a true coal. The courts decided that it was, and not until many years later was its true status determined.

The principal vein has been traced approximately 2800 feet and varies in thickness from several inches to a maximum of 17 ft. It is connected with a number of smaller lateral veins which in turn break up into still smaller offshoots. The maximum depth reached by mining operations was approximately 1400 ft., and it is estimated that altogether 230,000 tons have been mined. The main use of the product was to enrich bituminous coal in the manufacture of illuminating gas, but it is no longer available, as the mine has been inactive for many years.

This occurrence takes the form of a true fissure vein cutting across a series of beds of so-called "oil shales," which will be described in greater detail later (see p. 162). Mention should be made here that the surrounding shales abound in fossil remains of fish, which indicate that albertite and its associated shales are of animal origin.

On analysis it tests as follows:

(Test 1)	Color in mass.....	Black				
(Test 2)	Homogeneity.....	Uniform				
(Test 4)	Fracture.....	Conchoidal to hackly				
(Test 5)	Lustre.....	Bright				
(Test 6)	Streak.....	Brown to black				
(Test 7)	Specific gravity at 77° F.....	1.075-1.091				
(Test 9a)	Hardness, Moh's scale.....	2				
(Test 9b)	Hardness, penetrometer, 77° F.....	0				
(Test 9c)	Hardness, consistometer, 77° F.....	Greater than 150				
(Test 14c)	On heating in flame.....	Intumesces				
(Test 15)	Fusing-point.....	Infusible. Decomposes before it melts				
(Test 19)	Fixed carbon.....	25	-50%			
(Test 21a)	Soluble in carbon disulphide.....	2	-10%			
(Test 21b)	Non-mineral matter insoluble.....	85	-98%			
(Test 21c)	Mineral matter.....	0.1-	0.2%			
(Test 23)	Soluble in 88° naphtha.....	0.5-	2.0%			
(Test 24)	Solubility in pyridine (boiling).....	25	-35%			
		I	II	III	IV	V
(Test 26)	Carbon.....	83.44%	85.40%	85.53%	86.31%	87.25%
(Test 27)	Hydrogen.....	10.08	9.20	13.20	8.96	9.62
(Test 28)	Sulphur.....	0.44	Trace	1.20	Trace
(Test 29)	Nitrogen.....	3.10	0.42	2.90	1.75
(Test 30)	Oxygen.....	2.22	1.97
	Undetermined.....	6.04	0.12	0.10	1.21
		100.00%	100.04%	100.35%	100.24%	99.83%

¹ C. T. Jackson, *Proc. Boston Soc. Nat. Hist.*, **3**, 279; Wetherill, *Trans. Am. Phil. Soc., Philad.*, **353**, 1852; "Albertite," Dr. J. W. Dawson, F.G.S., "Acadian Geol." Edinburgh, p. 198, 1865; "Albertite," C. H. Hitchcock, *Amer. J. Sci.*, **39**, pt. 2, 267, 1865; W. P. Blake, *Trans. Am. Inst. Mining Eng.*, **18**, 563-82, 1889; Milner, *J. Mining Soc. Nova Scotia*, **17**, 62, 1912; "Oil Shales of America," by C. Baskerville and W. A. Hamor, *J. Ind. Eng. Chem.*, **1**, 507, 1909; **5**, 73, 1913.

Province of Nova Scotia

Pictou County. An unusual deposit occurs immediately below the well-known McGregor seam at Stellarton. The approximate thickness of the bed is given as 5 ft., subdivided as follows:

- (1) A layer of coal 1 ft. 4 in. wide.
- (2) A layer of albertite 1 ft. 10 in. wide.
- (3) A layer of pyrobituminous shale 1 ft. 10 in. wide.

The species of albertite has been exploited under the name "stellarite." It seems to represent a state of transition between true albertite and the cannel coals, of which the Scotch mineral torbanite (see p. 160) is a representative. The bed contains fossil animal and vegetable remains. A splinter of stellarite may be easily lighted with a match and will burn with a bright, smoky flame, throwing off sparks like stars (whence its name). It was formerly used to enrich bituminous coals in the manufacture of illuminating gas. The layer of coal is an ordinary fat-coking coal, showing a laminated structure, and containing 62.09 per cent of fixed carbon and 4.33 per cent of ash.

The stellarite and associated pyrobituminous shale tests as follows:

	<i>Stellarite (albertite)</i>	<i>Pyrobituminous shale</i>
(Test 1) Color in mass.....	Brown to black	Gray black
(Test 4) Fracture.....	Hackly	Conchoidal
(Test 5) Lustre.....	Semi-bright to dull	Dull
(Test 6) Streak.....	Reddish brown	Brown
(Test 7) Specific gravity at 77° F.....	1.07-1.10	1.56-1.78
(Test 15) Fusing-point.....	Infusible	Infusible
(Test 19) Fixed carbon.....	22.35-25.23%	8.3 -12.3%
(Test 21a) Soluble in carbon disulphide ..	2.0%	Trace
(Test 21c) Mineral matter.....	8.2 -8.9%	52.0-62.0%
(Test 25) Moisture.....	0.2 -0.3%	0.6- 1.0%
(Test 26) Carbon.....	88.1%
(Test 27) Hydrogen.....	11.1%
(Test 28) Sulphur.....	0.1%	6.25-0.74%
(Test 29) Nitrogen.....	0.2%
(Test 30) Oxygen.....	0.5%

The presence of the very small percentage of oxygen (0.5 per cent) differentiates the material from lignite and the other non-asphaltic pyrobitumens, thus corresponding with the ultimate analysis of the New Brunswick albertite.

UNITED STATES

Utah

Uinta County. A vein of albertite (christened "nigrite" by Eldridge, see p. 149), 120 ft. long, showing a maximum width of 20 in., is found 8 miles from Helper, and 5 miles east of Soldier Summit, having the following characteristics:

(Test 4) Fracture.....	Conchoidal
(Test 5) Lustre.....	Semi-dull
(Test 6) Streak.....	Brownish black to black
(Test 7) Specific gravity at 77° F.....	1.092-1.099
(Test 9a) Hardness, Moh's scale.....	2
(Test 14b) Heating in flame.....	Splits and burns
(Test 15) Fusing-point.....	Infusible
(Test 19) Fixed carbon.....	37 -40%
(Test 21a) Soluble in carbon disulphide.....	3 -6%

(Test 21b) Non-mineral matter insoluble.....	94.20-97%
(Test 21c) Mineral matter.....	0.2%
(Test 23) Soluble in 88° naphtha.....	Trace
(Test 28) Sulphur.....	1.0%

AUSTRALIA

Tasmania. A species of albertite described under the name of "tasmanite"¹ has been reported near the River Mersey in the northern portion of Tasmania. It is found disseminated in a pyrobituminous shale and complies with the following tests:

(Test 1) Color in mass.....	Black
(Test 2) Homogeneity.....	Uniform
(Test 4) Fracture.....	Conchoidal
(Test 5) Lustre.....	Bright
(Test 6) Streak.....	Yellowish brown
(Test 7) Specific gravity at 77° F.....	1.10
(Test 9a) Hardness, Moh's scale.....	2
(Test 15) Fusing-point.....	Infusible
(Test 21a) Soluble in carbon disulphide.....	Trace
(Test 21c) Mineral matter.....	8.14%
(Test 26) Carbon.....	79.2 - 79.3%
(Test 27) Hydrogen.....	7.2 - 7.4%
(Test 28) Sulphur.....	5.28 - 5.32%
(Tests 29 and 30) Nitrogen and oxygen.....	4.93%

WEST AFRICA

Libollo

A species of albertite is reported at this locality under the name "libollite."²

IMPSONITE

This represents the final stage in the metamorphosis of asphaltites and asphaltic pyrobitumens. It is characterized by its:

- (1) Infusibility and insolubility in carbon disulphide;
- (2) Specific gravity (1.10 to 1.25);
- (3) High percentage of fixed carbon (50 to 85 per cent);
- (4) Comparatively small percentage of oxygen (less than 5 per cent), which differentiates it from the non-asphaltic pyrobitumens.

The weathered asphaltities taken from the exposed portions of the vein, where they have been subjected for centuries to the action of the elements, closely resemble impsonite in their physical and chemical properties, and may therefore be classified as such. Outcrops of grahamite are especially prone to metamorphize into impsonite, and many prospectors have been misled on this account.

¹A. J. Church, *Phil. Mag.*, **28**, 465, 1864; Newton, *Geol. Mag.*, **2**, 336, 1875; Stephens, *Proc. Roy. Soc. Tas.*, **5**, March, 1876.

²Gomes, *Comm. Dir. Trabalhos Geol.*, Portugal, **3**, 244-290; **4**, 206, 1896-8.

The following represent the most important deposits:¹

UNITED STATES

Oklahoma

La Flore County. One of the largest deposits of impsonite occurs 2 miles east of Page on the southern slope of Black Fork Mountain (S ½, Sec. 24, T 3 N, R 26 E), filling a fissure caused by a fault. The vein is about 10 ft. thick, and has been mined to some depth. It complies with the following tests:

(Test 1)	Color in mass.....	Black
(Test 4)	Fracture.....	Hackly
(Test 5)	Lustre.....	Semi-dull
(Test 6)	Streak.....	Black
(Test 7)	Specific gravity at 77° F.....	1.235
(Test 9a)	Hardness, Moh's scale.....	2-3
(Test 14b)	Heating in flame.....	Decrepitates
(Test 15)	Fusing-point.....	Infusible
(Test 19)	Fixed carbon.....	75.0-81.6%
(Test 21a)	Soluble in carbon disulphide.....	4 -6%
(Test 21b)	Non-mineral matter insoluble.....	93 -96%
(Test 21c)	Mineral matter.....	0.7- 2.5%
(Test 24)	Solubility in pyridine (boiling).....	3.88%
(Test 25)	Moisture.....	0.1- 1.5%
(Test 28)	Sulphur.....	1.69%

Murray County. Impsonite has been reported 5 miles northeast of Dougherty (Sec. 33, T 1 S, R 3 E), in a vein about 18 in. thick at the top and 7 ft. at the bottom. Its characteristics are similar to the preceding.

Arkansas

Scott County. Another deposit of Impsonite occurs in the western part of Fourche Mountain, about 12 miles east of the Black Fork Mountain locality in Oklahoma. The exact locality is 1 mile east of Eagle Gap, and 2 miles east of Harris. It occurs in a region of shale and sandstone, and tests as follows:

(Test 1)	Color in mass.....	Black
(Test 4)	Fracture.....	Hackly
(Test 5)	Lustre.....	Semi-dull
(Test 6)	Streak.....	Black
(Test 7)	Specific gravity at 77° F.....	1.25
(Test 9a)	Hardness, Moh's scale.....	3
(Test 14b)	Heating in flame.....	Decrepitates
(Test 15)	Fusing-point.....	Infusible
(Test 19)	Fixed carbon.....	80.0%
(Test 21b)	Non-mineral matter insoluble.....	99.3%
(Test 21a)	Soluble in carbon disulphide.....	Trace
(Test 21c)	Mineral matter.....	0.6%
(Test 28)	Sulphur.....	1.38%

Nevada

Eureka County. A deposit is reported 15 miles south of Palisade in Pine Creek valley, in a vein filling a fault about 300 ft. long and of unknown depth. Its physical and chemical characteristics are similar to the preceding.²

¹"Grahamite Deposits Found in Eastern Oklahoma," by J. A. Taff, Bulletin No. 380, U. S. Geol. Survey, Wash., D. C., p. 295, 1909.

²"An Occurrence of Asphaltite in Northeastern Nevada," by Robert Anderson, Bulletin No. 380, U. S. Geol. Survey, Wash., D. C., p. 283, 1909.

CHAPTER XII

PYROBITUMINOUS SHALES

UNDER this heading will be considered the *oil-forming* shales containing pyrobitumens associated with earthy matter, which will produce oily or tarry distillates upon being subjected to destructive distillation. *Oil-bearing* and *asphalt-bearing* shales from which petroleum or asphalts may be extracted with solvents are not included. The well-known shales in France occurring at Autun (Saône-et-Loire) and Bruxières-les-Mines (Allier) consisting of semi-liquid asphalt associated with shales shall accordingly be excluded, although these have been classified indiscriminately with the true pyrobituminous shales by other writers.

Pyrobituminous shales may be sub-divided into two classes:

(1) Asphaltic pyrobituminous shales in which asphaltic pyrobitumens (elaterite, wurtzilite, albertite or imponite) are associated with shales.

(2) Non-asphaltic pyrobituminous shales in which non-asphaltic pyrobitumens (cannel coal, lignite or bituminous coal) are associated with shales.

Little or no attempt has been made to differentiate between these two groups, on account of the difficulty in identifying the bituminous material present. This will become apparent when it is considered that pyrobitumens are substantially insoluble in solvents and are moreover masked by the associated mineral matter, which interferes with the usual distinguishing tests, such as the specific gravity, lustre, streak, etc. Up to the present time all pyrobituminous shales have been referred to under the general term "oil shales," which is really a misnomer.

The following means are suggested to differentiate the two classes:

(1) By the pyrobitumens found locally.

The presence of asphaltic bitumens in the vicinity would indicate an asphaltic pyrobituminous shale. Similarly, non-asphaltic pyrobitumens would tend to establish the identity of the shale as non-asphaltic. If both types are present, the evidence is non-conclusive.

(2) By the associated fossil remains.

If vegetable (plant) fossil remains *only* are found associated with the

shale, the indications are that it is non-asphaltic, since it is definitely established that the non-asphaltic pyrobitumens are of *vegetable* origin. On the other hand, if animal (fish or mollusc) fossil remains are present, the shale will more than likely represent the asphaltic pyrobituminous variety.

(3) Effect of heat on the solubility,—

On heating in a closed retort to 300 to 400° C., asphaltic pyrobituminous shales will depolymerize and become more soluble in carbon disulphide (see p. 57), whereas the non-asphaltic pyrobituminous shales remain unaffected.

(4) By the percentages of fixed carbon and oxygen (calculated on the basis of the non-mineral matter present). These two criteria, considered together, furnish the most reliable means of distinguishing between the two classes of shale, as will be observed from the following figures, calculated on the basis of the non-mineral constituents present:

	Per Cent Fixed Carbon (Calculated on the Mineral-free Basis).	Per Cent Oxygen (Calculated on the Mineral-free Basis).
<i>Asphaltic Pyrobituminous Shales:</i>		
Wurtzilite shales	2-10	Less than 2
Albertite shales	5-25	Less than 3
<i>Non-asphaltic Pyrobituminous Shales:</i>		
Cannel coal shales	5-20	5-10
Lignite shales	15-30	15-28
Bituminous coal shales	25-50	3-18

It will be noted that the percentage of fixed carbon calculated on the mineral-free basis, runs lower than in the corresponding (pure) pyrobitumens (see p. 60 and p. 483), due to the presence of the mineral matter, which assists in the combustion of the carbon during the test, decreasing the yield of "fixed carbon," and at the same time increasing the percentage of volatile constituents. This is important from a commercial view-point. The most valuable pyrobituminous shales are those which produce the largest amount of volatile matter when subjected to destructive distillation. This is true with the albertitic cannel coal (torbanitic) and lignitic shales, whereas the bituminous coal shales yield but little volatile matter and have no commercial importance. Two types of bituminous constituents are present in non-asphaltic pyrobituminous shales, viz.: (1) macerated and carbonized plant remains similar to coal, and (2) yellow resinous bodies representing the last stage

in the oxidation of the woody tissue.¹ Elaterite, wurtzilite and impsomite shales are rarely found.

Before taking up the shales proper, we will first consider the proto-substances of the cannel-coal shales, namely the "cannel" or "parrot coals" (called so on account of the crackling noise taking place on combustion), of which "torbanite" and "pyropissite" are the best known examples. These represent the pure bituminous constituents as they occur in the respective shales, and accordingly furnish a valuable insight into the composition of the shales themselves. (See p. 60.)

Torbanite is now extinct, but was mined in large quantities at Torbane Hill, near Bathgate in Linlithgowshire, Scotland, from 1850 to 1862. It is also known under the names "torbanehill mineral," "boghead cannel coal," and "bathvillite," and tests as follows:

(Test 1)	Color in mass.....	Brown to nearly black
(Test 2)	Homogeneity.....	Uniform and amorphous
(Test 4)	Fracture.....	Sub-conchoidal
(Test 5)	Lustre.....	Dull
(Test 6)	Streak.....	Yellowish
(Test 7)	Specific gravity at 77° F.....	1.17-1.32
(Test 9a)	Hardness, Moh's scale.....	2
(Test 14b)	Heating in flame.....	Ignites, splits and burns
(Test 15)	Fusing-point.....	Infusible
(Test 19)	Fixed carbon.....	6.6-13.3%; average 7.65%
	Same calculated on non-mineral matter.....	9.6%
(Test 21a)	Soluble in carbon disulphide.....	Slight
(Test 21c)	Mineral matter.....	12.8-23.2%
(Test 23)	Solubility in 88° naphtha.....	Less than 1.5%
(Test 26)	Carbon.....	78.67-78.86%
(Test 27)	Hydrogen.....	11.11-11.46%
(Test 28)	Sulphur.....	0.50-0.70%
(Test 29)	Nitrogen.....	0.55-1.37%
(Test 30)	Oxygen.....	9.68-10.22%

Torbanite differs from the asphaltic pyrobitumens in its physical properties, also in containing a greater percentage of oxygen and because it shows distinct signs of having originated from plant growth. For many years there was much discussion regarding the exact status of torbanite, and whether or not it represented a true coal.² It probably represents a state of transition between vegetable matter and the true non-asphaltic pyrobitumens. The cannel or boghead shales found in the Lothians (Scotland) consist of bituminous substances of the nature of torbanite (termed "kerogen" by the Scottish geologists) associated with more or less mineral matter.

Pyropissite is a species of cannel coal, formerly mined at Weissenfels, near Halle, Saxony. It contains plant remains, showing unmistakable traces of the cellular tissue, and tests as follows:

(Test 1)	Color in mass.....	Grayish brown
(Test 2)	Homogeneity.....	Uniform

¹ H. R. J. Conacher, *Geol. Mag.*, 4, 93, 1917.

² Watson Smith, *J. Soc. Chem. Ind.*, 28, 398, 1909.

(Test 4) Fracture.....	Semi-conchoidal
(Test 5) Lustre.....	Earthy
(Test 6) Streak.....	Yellowish-brown
(Test 7) Specific gravity at 77° F. (dry material).....	0.9-1.1
(Test 14b) Behavior on heating in flame.....	Melts easily to a pitch-like mass
(Test 19) Fixed carbon.....	10-15%
(Test 21a) Solubility in carbon-disulphide (when dry).....	60%
(Test 21b) Non-mineral matter insoluble.....	32.3%
(Test 21c) Mineral matter.....	7.7-12.1%
(Test 25) Water.....	Variable; up to 50-60%
(Test 26) Carbon.....	77.0%
(Test 27) Hydrogen.....	12.6%
(Test 28) Sulphur.....	0.2%
(Test 29) Nitrogen.....	0.3%
(Test 30) Oxygen.....	9.9%
Total.....	100.0%
(Test 33) Paraffine.....	62%

It will be observed that pyropissite contains a good proportion soluble in carbon disulphide, i.e., the so-called montan wax (see p. 79), and may therefore be considered a "semi-pyrobitumen," falling on the border line between vegetable matter and non-asphaltic pyrobitumens. In the same way, the pyropissitic shales may be classified as "semi-pyrobituminous shales." On destructive distillation, pyropissite yields: gases 8-12 per cent, water 8-12 per cent, tar 64-66 per cent (specific gravity 0.84-0.91) and coke 12-26 per cent.¹

We will now consider the more important deposits of pyrobituminous shales throughout the world:

UNITED STATES

Lignitic and bituminous coal shales² are found in the States of Kentucky (Breckenridge County), Virginia, Tennessee, north-western Colorado (in the neighborhood of the Green River), northwestern Utah, Missouri, Nevada (Humboldt River opposite Elko), Wyoming, Montana (Big Blackfoot River near Green Falls) and California (Cholame Valley north of Parkfield).

The principal beds of pyrobituminous shale may be traced along a line from central Alabama, northeastward through Tennessee and Virginia, and thence westward across central Ohio, passing close to Columbus, reaching the Ohio River near Vanceburg. From this point, the shale makes a loop through central Kentucky, past Lebanon, extending to Louisville, from which it stretches in a broad belt northwestward across

¹ Scheithauer, "Fabrikation der Mineralöle," p. 21.

² Second Rept., Geol. Surv., Kentucky, 7, 211, 1856; "Oil Shales of America," Baskerville and Hamor, *J. Ind. Eng. Chem.*, 507, 1909; "American Oil Shales," Baskerville and Hamor, 8th, Intern. Cong. of Appl. Chem., 25, 631, 1912; Day in "Mineral Resources of the United States," 11, 1071, 1913; Woodruff and Day, Bull. 581-A, U. S. Geol. Surv., Wash., D. C., 1915; De Beque, *Eng. Mining J.*, 99, 773, 1915; U. S. Comm. Rept., March 13, 1916; "Oil Resources of Black Shales of the Eastern U. S.," G. H. Ashley, Bull. 641-L, U. S. Geol. Surv., Wash., D. C., 1917.

Indiana, past Indianapolis, almost reaching Chicago. They are known as the Chattanooga, New Albany and Ohio Shales.

CANADA¹

Province of New Brunswick. Pyrobituminous shales, known as "albert shales," or "arcadian shales" (termed "oilite" by the local geologists) have a wide distribution in Westmoreland, Albert and Kings counties. On destructive distillation these shales yield products similar to those derived from the distillation of albertite, and the composition of the non-mineral matter is supposedly similar to the latter. The albert shale series in places attains a thickness of about 1000 ft. and is made up principally of the shales themselves, associated with other inter-bedded sedimentaries. In color the shales may be either gray, dark brown or black. Certain varieties, such as the so-called "curly" shales, show a massive structure and break with a conchoidal fracture, while others have a laminated structure and separate readily into thin, flexible layers. In the massive varieties, veinlets of glossy black material, resembling albertite, are not uncommon. Fossil remains of fish abound, especially in the laminated varieties.

The shales found at Turtle Creek in the neighborhood of Baltimore, Albert County, have the following composition:

Moisture.....	0.36- 1.54%
Ash.....	44.21-56.10%
Fixed carbon.....	3.29- 5.05%
Sulphur.....	1.04- 1.70%

Ultimate analyses are not available, but there seems to be little question that the non-mineral matter closely resembles albertite.

Province of Nova Scotia. Asphaltic pyrobituminous shales, also known as "arcadian shales," are found in Pictou and Antigonish counties. Some of the shales are of the asphaltic and others of the non-asphaltic pyrobituminous class. Of the former the so-called "stellarite shales" in Pictou (see p. 155) may be cited as an example. True coals are also found in this region, associated with coal shales (lignitic and bituminous).

Newfoundland. Black bituminous shales occur on the north side of Notre Dame Bay, Cap Rouge Peninsular and in the neighborhood of Deer and Grand Lakes. These are probably of the nature of bituminous coal. Analysis of one specimen shows it to contain:

Fixed carbon.....	35%
Ash.....	29%

Province of Quebec. Pyrobituminous shales, or shaly sandstones, occur on certain streams emptying into the Gaspé Basin, principally along the York and Dartmouth rivers. Thus far, these shales are of scientific interest rather than of commercial importance. Unlike the shales of New Brunswick, the bituminous constituents occur as small particles physically combined with rather fine-grained shaly sandstone bands. These particles are of a black or brown color, and show a

¹"Mineralogy of Nova Scotia," by H. How; Canadian Dept. of Mines for 1908, Bull. 1072, p. 132; Bull. 1120, p. 200, 1909; "Joint Report of the Bituminous Oil-shales of New Brunswick and Nova Scotia," Bulls. 55 and 1107, 1910; "The Oil Shales of the Maritime Provinces," by R. W. Ells, *J. Mining Soc. Nova Scotia*, 14, 1909-10.

pale yellow streak, conchoidal fracture, and vitreous lustre. The shales contain from 50 to 70 per cent of mineral matter, and yield 7 to 10 per cent fixed carbon. They are therefore probably of the asphaltic pyrobituminous variety.

The so-called "Utica Shales" are found along the St. Lawrence River all the way from Quebec to Montreal. Farther west the shales may be traced along the Ontario Peninsula along the shore of Lake Ontario in the vicinity of Port Hope, continuing along the shore of Lake Huron near Georgian Bay, and particularly in the neighborhood of Collingwood. These contain about 90 per cent of mineral matter, the non-mineral constituents being probably of a ligneous character.

BRAZIL

Province of Bahia. Pyrobituminous shales of uncertain composition have been reported in the Camamu basin.¹

ENGLAND

A belt of pyrobituminous shales of the lignitic and cannel coal varieties (known as the Kimmeridge Shales) stretches from Dorsetshire across to Lincolnshire and Norfolkshire in thin seams.²

SCOTLAND

This is the home of the shale industry, which is still being worked very actively. The Scotch shales (known as "Lothian") as at present worked occur in a well-defined area lying 12 miles west of Edinburgh on the south side of the Firth of Forth, from Hopetoun southwards for 16 miles to Cobbenshaw, varying in width from 3 to 8 miles.³ They occur as a fine-grained, brownish, brownish black to black clay shale in the Upper Calciferous Sandstone Series, having a distinctly laminated fracture, a dull lustre, and a specific gravity at 77° F. of 1.75. Rich shales also occur on the north side of the Forth in Fifeshire; and in Edinburghshire and Linlithgowshire, strata of shales are found in the Lower Calciferous Sandstone Series, not very rich, but which may nevertheless pay to work some day. The shales are divided into two classes known as "plain" and "curly" depending upon the predominance of the laminated structure. The best varieties are distinguished by being cut into thin shavings with a sharp knife without breaking. These shales may be classed as torbanitic, and are now mined in the following counties:

Edinburghshire (mid Lothian). *Pumphreston, Oakbank, New Farm, Roman Camp, Ingleston, Limefield, and Cousland.*

¹ Branner, *Trans. Am. Inst. Mining Eng.*, **30**, 537, 1901.

² "Kimmeridge Shale, Its Origin, History, and Uses," Burton Greene. London. 1886; "Petroleum and Its Products," Boverton Redwood, Vol. 1, 1st Edition, p. 14; Williams, *J. Chem. Soc.*, **7**, 97; *Phil. Mag.*, **8**, 209.

³ "A Practical Treatise of Mineral Oils and Their By-products," by Iltud Redwood. London, 1897; "Oil Shales of the Lothians," Part I: "Geology of the Oil Shale Fields," by H. M. Cadell and I. S. Grant Wilson; Part II: "Methods of Working Oil Shales," by W. Caldwell; Part III: "Chemistry of the Oil Shales," by D. R. Steuart; issued by the Dept. of Mines, Geol. Survey, Scotland, 1906; *Trans. Inst. Mining Eng.*, **22**, 314 E, 1902; "The Shale Oil Industry," D. R. Steuart, *J. Soc. Chem. Ind.*, **14**, 774, 1916.

Linlithgowshire (West Lothian). *Broxburn, Dalmeny, Bathgate, Uphall, Philipstoun, Forkneuk, Addiewell, Hopetoun, Westwood, Deans, Seafield and Newliston.*

Fifeshire. *Burntisland* (now stopped).

Lanarkshire. *Tarbrax and Cobbinshaw.*

Stirlingshire. *Blackrigg.*

Renfrewshire.

Ayrshire.

In these counties, in the early days of the industry, cannel coal and shales were mined from strata at a higher horizon than the Calceiferous Sandstone Series in the coal measures, but the deposits have since been exhausted.

GERMANY

Pyropissitic and lignitic shales are found in Rhenish Prussia, Saxony (in the so-called Halle District at Halle, Weissenfels, Zeitz, Aschersleben and Eisleben), Hesse (Messel near Darmstadt), Bavaria and Wittenberg (Reutlingen).¹

SPAIN

Shales of uncertain composition occur in the Ronda District in the southern portion of Spain.

AUSTRIA

Lignitic shales are found in Moravia, Bohemia and in the Tyrol.

AUSTRALIA²

New South Wales. Here we find the coorangitic shale designated locally as "kerosene shale," the non-mineral portion of which corresponds to the asphaltic pyrobitumen coorangite (see p. 150), the joadja shale, the classification of which is questionable, and the asphaltic pyrobituminous shales of the Wolgan and Capertee Valleys at Murrurundi, Torbane, Capertee, and Wolgan.

New Zealand. Here the shales are reported to occur at Orepuki.

Tasmania.

Queensland.

Victoria.

From the foregoing it will be apparent that the subject of "pyrobituminous shales" is an extremely complicated one, still requiring a vast amount of research work before all the deposits can be correctly classified.

Pyrobituminous shales are treated exclusively by subjecting them to a process of destructive distillation in suitable retorts to recover the tarry distillate and ammonium sulphate as will be described in Chapter XVI. The intrinsic value of the shale is dependent upon the amount of shale tar and ammonium sulphate obtained. It is interesting to note in passing that Steuart obtained a product resembling crude shale oil upon subjecting a mixture of lycopodium spores and clay to destructive distillation.

¹ "Shale Oils, and Tars and Their Products," by Dr. W. Scheithauer. London, 1913.

² Annual Report Col. Mun. Lab. N. Z., 23, 50; 25, 56; 29, 19; 31, 10; Petrie, *J. Soc. Chem. Ind.*, 24, 996; Dunlop, Rept. Dept. Mines, N. Z., C 3, 52, 1900; "The Kerosene Oil-shales of New South Wales," J. E. Carne, 1903; Bull. Queen. Gov. Min. D., December 15, 1915.

PART III

TARS AND PITCHES

CHAPTER XIII

GENERAL METHODS OF PRODUCING TARS

TARS constitute the volatile oilyde composition products obtained in the pyrogenous treatment of bituminous and other organic substances, and represent distillates of dark color, liquid consistency; having a characteristic odor; comparatively volatile; of variable composition; sometimes associated with carbonaceous matter, the non-carbonaceous constituents being largely soluble in carbon disulphide; and whose distillate fractioned between 300 and 350° C. yields comparatively little sulphonation residue. The pyrogenous treatment embraces three processes, viz.:

(1) Subjecting to heat alone without access of air, often termed "destructive distillation."

(2) Partial combustion, which may take place either in an atmosphere of air and steam (in gas producers) or with a limited access of air.

(3) Cracking oil vapors at high temperatures.

Practically all organic substances which undergo decomposition upon being subjected to heat produce tars, provided they yield a substantial proportion of volatile decomposition products, the temperature is sufficiently high to bring about the decomposition, and air is entirely or partially excluded during the pyrogenous treatment. If the organic substance does not contain volatile matter, as proves the case with anthracite coal or graphite, no tar will result. If air is present in too large a quantity, the products of decomposition will undergo *complete* combustion, and the tar will be consumed. Materials which evaporate (i.e. distil undecomposed) or sublime will remain unchanged in composition, and products that explode are converted into permanent gases, without the formation of tars.

At the present time tars are produced commercially from the following products:

(1) Bituminous substances including peat, lignite, bituminous coal, petroleum and pyrobituminous shales.

(2) From certain other organic substances including wood, and bones.

In the early days of the industry, tars were also produced during the destructive distillation of grahamite and albertite (see page 221).

The following table will give a synoptical outline of the raw materials used, the modes of treatment, and the kinds of tar produced:

TABLE XV.

Raw Materials Used.	Heat Alone ("Destructive Distillation").	Partial Combustion.		"Cracking" of Oil Vapors.
		Air and Steam ("Producers")	Limited Access of Air.	
<i>Bituminous substances:</i>				
Petroleum products.....	Oil-gas tar Water-gas tar
Peat.....	Peat tar.....	Peat tar.....
Lignite.....	Lignite tar.....	Lignite tar.....
Pyrobituminous shales.....	Shale tar.....	Shale tar.....
Bituminous coals.....	Gas-works coal tar Coke-oven coal tar	Producer-gas coal tar	Blast-furnace coal tar
<i>Other Organic Materials:</i>				
Wood.....	Wood tar.....
Bones.....	Bone tar.....

Petroleum products (e.g., "gas oils") upon being subjected to a high temperature under more or less pressure in a closed retort will result in the formation of oil-gas tar; and when sprayed on incandescent anthracite coal or coke result in the production of water-gas tar (page 256). Peat, lignite and pyrobituminous shales result in the formation of peat-, lignite- and shale tars respectively, (1) when subjected to destructive distillation, or (2) upon undergoing partial combustion in an atmosphere of air and steam in a so-called "gas producer." Tars resulting from these two processes are similar in composition and hence are designated by the same name. Destructive distillation yields a larger percentage of tar than partial combustion in an atmosphere of air and steam.

Bituminous coals form different kinds of tar depending upon the nature of the process. Thus gas-works coal tar and coke-oven coal tar are produced by the destructive distillation of bituminous coal in gas-

works retorts and coke-ovens respectively. Producer-gas coal tar is derived from the partial combustion of bituminous coal in an atmosphere of air and steam in a gas producer. Blast-furnace coal tar results from the partial combustion of bituminous coal in a limited access of air in a so-called "blast furnace."

Destructive distillation of wood results in the formation of wood tar, and of bones in the production of bone tar.

In the order of their commercial importance, based on the quantities produced annually, tars may be grouped as follows, viz.: coke-oven coal-tar is produced in the largest quantity, gas-works coal tar comes next, water-gas tar, oil-gas tar and wood tar following in sequence. Insignificant quantities of producer-gas coal tar, bone tar, blast furnace coal tar, peat, lignite and shale tars are produced in the United States. Considerable shale-tar is produced in Scotland, also smaller quantities of blast-furnace coal tar. Lignite tar is produced in comparatively large quantities in Germany. The production of peat and bone tar has not assumed great importance anywhere.

We will now consider the various processes for producing tars in greater detail.

DESTRUCTIVE DISTILLATION

This process is used for destructively distilling *infusible* organic substances including non-asphaltic pyrobitumens, pyrobituminous shales, wood and bones. It consists in heating the substance to a high temperature in a still from which air is excluded, and the distillation is continued until the volatile constituents are driven off the residue carbonizes. The volatile constituents are grouped into two classes, viz.: non-condensable and condensable products, the former including the permanent gases, and the latter the aqueous liquor and tar.

The nature of the ingredients formed during the distillation depends largely upon the nature of raw material used and the temperature at which it undergoes decomposition. As a rule, the older the substance from a geological stand-point, the higher the temperature at which it decomposes. At low temperatures, we find aliphatic (straight chain) hydrocarbons in the tar, also varying amounts of phenolic bodies, of toluene and naphthalene, but no benzene or anthracene. This is true in the case of peat, lignite, cannel coal and pyrobituminous shales. Where the destructive distillation takes place at a high temperature, aromatic hydrocarbons will predominate, including benzene and anthracene. This is true with bituminous coals. The aqueous liquor will show an

acid reaction in the case of wood and peat, and an alkaline reaction with lignite, coals and pyrobituminous shales.

In general, the yield of tar depends upon five factors, viz.: the composition of the substance, the temperature, the time of heating, the pressure, and upon the efficiency of the condensing system. These will be considered in greater detail.

The Composition of the Substance. (a) *The Percentage of Volatile Constituents.* The greater the percentage of volatile constituents, and conversely the smaller the percentage of "fixed carbon," the larger the yield of tar. Figured on the basis of the dry weight of the non-mineral constituents, the yield of volatile matter will range as follows, commencing with the highest: wood, peat lignite, bituminous coal. The yields of tar follow in the same sequence, viz.:

Wood.....	10 -20%
Peat.....	7½-15%
Lignite.....	5 -10%
Bituminous coal.....	3 - 7%

(b) *The Percentage of Oxygen in the Fuel.* As a general rule, the greater the percentage of oxygen in the fuel, the greater the yield of tar. George Lunge¹ cites the following figures to show the relation between the percentages of oxygen, tar, and water, based on the dry weight of fuel:

Fuel Contains Per Cent.	Yield Tar, Per Cent.	Yield Water, Per Cent.
Oxygen 5 - 6½.....	3.50	4.58
Oxygen 6½- 7½.....	4.65	5.86
Oxygen 7½- 9.....	5.08	6.80
Oxygen 9 -11.....	5.48	8.60
Oxygen 11 -13.....	5.59	7.86

The Temperature. (a) *The Temperature at which the Fuel Decomposes.* As stated previously, each type of fuel has a definite temperature at which distillation commences. The older the fuel from a geological standpoint, the higher this temperature, and hence the greater yield of coke, and the smaller that of tar. It would appear that a preliminary decomposition approaching a state of fusion occurs at this temperature which remains fairly constant until the carbonization is complete. The coke-forming property of bituminous coals depends upon the presence of constituents melting at a lower temperature than that at which carbonization becomes appreciable.

The kindling temperatures of the various fuels are:

Dried wood.....	400° F.
Dried peat.....	450° F.
Dried lignite.....	500° F.
Bituminous coal.....	600° F.
Anthracite coal.....	750° F.
Coke.....	1000° F.

¹"Coal Tar and Ammonia," 5th Edition. New York. 1916.

(b) *The Temperature at which the Distillation is Performed.* This is distinct from the preceding, and is determined by the quantity and intensity of the heat applied externally to the retort in which the destructive distillation takes place. It depends upon the nature of the heating medium, and the manner in which it is applied. The temperature may be close to that at which the fuel undergoes distillation, or it may be vastly in excess thereof. The higher the temperature above that necessary to cause incipient decomposition, the smaller the yield of tar, and the larger that of gas. This is strikingly illustrated by the following figures relating to the same coal distilled under different conditions:

Low-temperature carbonization: Yield per ton: 16 gals. tar and 9000 cu. ft. gas.
High-temperature carbonization: Yield per ton: 9 gals. tar and 11,000 cu. ft. gas.

With a Derbyshire shale and a Notts cannel coal, the following yields of tar were obtained:

	Derbyshire Shale, Per Cent.	Notts Cannel Coal, Per Cent.
Low temperature carbonization.....	7	11
Normal temperature carbonization.....	6	10
High temperature carbonization.....	5	9

A Derbyshire coal which contained: carbon, 75.71 per cent; hydrogen, 6.27 per cent; sulphur, 1.72 per cent; nitrogen, 1.72 per cent; oxygen, 11.59 per cent; and ash, 2.99 per cent; yielded the following per 100 kilograms:

Carbonized at 800° C.: Tar, 6.43 litres (specific gravity 1.00, containing 15 per cent of free carbon) and coke, 64.75 kilograms.

Carbonized at 1100° C.: Tar, 5.37 litres (specific gravity 1.207, containing 30 per cent of free carbon) and coke 64.16 kilograms.

It will be observed that a high temperature resulted in the formation of a larger percentage of free carbon in the tar, due to greater decomposition ("cracking") of the distillate.

A certain bituminous coal, when carbonized at a low temperature (400-600° C.) produced unsaturated hydrocarbons, higher paraffines and oxygenated compounds. Between 600 and 800° C. methane and hydrogen were evolved, and at temperatures above 800° C. the main product was hydrogen. In a laboratory test, it was found that on passing mixture of hydrogen and methane in equal volumes through heated coke at a temperature of 800° C., 2 per cent of the methane was decomposed into hydrogen, and at 1100° C., 65 per cent was decomposed.

Aromatic hydrocarbons, upon being subjected to a gradually increasing temperature (650°-800° C.), are transformed as follows:

Higher Benzene Homologues → Lower Benzene Homologues → Diphenyl → Naphthalene → Anthracene.

At temperatures above 800° C., the anthracene is decomposed into carbon and gas.¹

¹ *J. Ind. Eng. Chem.*, **7**, 1019, 1915; **8**, 105, 1916; "The Pyrogenesis of Hydrocarbons," by A. E. Dunstan and F. B. Thole, *J. Ind. Eng. Chem.*, **9**, 888, 1917.

The Time of Heating. (a) *Thickness of the Fuel Layer.* The deeper the layer of fuel in the retort or furnace, the greater the superheating, and consequently the smaller the yield of tar and the larger that of gas. When the layer is deep, the volatile portions are compelled to pass through a mass of incandescent fuel, so that the temperature of the gases is increased, due to the greater *time* of contact. This is the underlying principle in the manufacture of generator gas.

It follows also that the greater the area of contact between the fuel and the heating surface, the shorter time it will take to raise the temperature of the former the requisite degree. Small charges of fuel may thus be heated more rapidly, which is conducive to the formation of a greater proportion of gas and tar and a smaller yield of coke. Slow heating, on the other hand, results in the production of a large proportion of coke, and smaller proportions of gas and tar respectively. It is for this reason that comparatively small and narrow retorts are used for the manufacture of illuminating gas, and very much larger chambers, where coal is treated to obtain coke.

According to Ramsburg and Sperr,¹ the coking action progresses from the walls to the centre of the oven. The actual thickness of the coking zone is not much over $\frac{1}{2}$ in., but the drop in temperature across it is very great. It is estimated that in an oven 18 in. wide, with a wall temperature of 1000° C., the average rate of advance is $\frac{1}{2}$ in. per hour. As this action progresses from all sides of the retort, it follows that the smaller its diameter, the shorter the time required to complete the process.

(b) *Size of the Fuel.* The size of the lumps of fuel has an important bearing on the time of heating. If the lumps are too fine, they will pack together to such an extent that insufficient space is left between them for the transfer of heat by the gaseous products. On the other hand, if the lumps are too large, it will take an abnormally long time for the carbonization process to reach the centre of each lump, since the heat conduction of the fuel itself is poor. The proper size of the lumps is a question upon which almost every gas engineer has his own particular views.

(c) *Construction of the Retort or Furnace.* The thickness of the walls, the method of heating, the size as well as the nature of the material of which the retort is constructed, all tend to influence the time of heating. Small units, the use of preheated gases for supporting the combustion, thin retort walls constructed of materials which have a relatively high conductivity at elevated temperatures, serve to decrease the time of heating. Fire clay was formerly used for constructing the retort. Recently, however, silica has been adopted for the purpose on account of its superior strength and heat-conductivity at high temperatures.

For manufacturing illuminating gas either horizontal, inclined, or vertical retorts have been used. In horizontal retorts, since it is impractical to fill the retort completely with fuel, considerable overheating of the volatile constituents will take place, due to their greater contact with the highly heated upper surface of the retort between the top of the fuel and the top part of the retort. In the inclined and vertical varieties, this space is decreased and consequently there is less opportunity for overheating the products evolved during the distillation process.

¹J. Franklin Inst., 183, 319, 1917.

The following figures show the influence of the retort's inclination on the yield:

	Vertical Retort, Per Cent.	Inclined Retort, Per Cent.	Horizontal Retort, Per Cent.
Yield of tar.....	6	5½	4
Free carbon in the tar.....	5	10	30
Pitch obtained from the tar....	50	55	65

Upon the Pressure. The greater the pressure, the longer the volatile products are forced to remain in contact with the hot retort and incandescent fuel, and the greater, therefore, the carbonization. The use of reduced pressure hastens the removal of the volatile constituents and serves to increase the outputs of gas and tar, and to reduce the yield of coke. At the same time the period of distillation is increased. In manufacturing illuminating or fuel gas, modern practice consists in carrying out the distillation under a moderate vacuum. On the other hand, when the main object is to produce coke, the pressure of the gas inside the retort is purposely allowed to increase somewhat.

Upon the Efficiency of the Condensing System. As the vapors leave the retort, oven, blast-furnace, or producer at 500 to 800° C., all the constituents exist in the gaseous state, excepting the "free carbon" derived from the decomposition of the gases in contact with the highly heated walls, also particles of mineral matter carried over mechanically. The vapors are composed of a mixture of substances, some congealing to solids, others condensing to liquids, and still others remaining as permanent gases at atmospheric temperature and pressure. As the vapors cool, the solids and liquids separate out, forming the tar. This separation is generally progressive, the higher boiling-point constituents condensing first, followed by substances of lower boiling-points, and finally liquids boiling slightly above atmospheric temperature. With this in view, the vapors may either be cooled slowly and the several fractions recovered separately by the Feld system (see p. 249), or they may be cooled rapidly, so that all condensible constituents are caught together in the form of "tar," to be redistilled later into its components. It is a singular fact, that even when the vapors have been thoroughly cooled, the tar will not separate out completely, without further treatment. Part remains suspended in the gases as infinitesimally fine globules, known as a "tar fog." This term is most expressive, since its behavior is very similar to that of an ordinary fog, alluding to the weather. Mere cooling will not condense a "tar fog," accordingly other means must be employed, as will be described later (p. 180).

It is evident that the yield of tar depends largely upon the efficiency of the condensing system used in its recovery, of which the more important types will be considered in this chapter.

PARTIAL COMBUSTION WITH AIR AND STEAM

This takes place in manufacturing producer gas. Several forms of producers are in use, and peat (page 201), lignite (page 209), pyrobituminous shale (page 216) or bituminous coal (page 239) are variously employed as fuel. The reaction which ensues may be expressed as follows, in which "C" represents the carbonaceous matter present in the form of fuel:

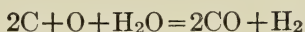

The resulting gas, known as "producer gas," is composed of carbon monoxide with a smaller proportion of hydrogen. When anthracite coal or coke is used as fuel, no tar results; with bituminous coal, tar is formed in certain types of producers but not in others (see page 240); and with peat or lignite, tar is produced in all types (see page 166), on account of the readiness with which they volatilize at low temperatures, and the comparatively large proportion of volatile constituents present. These tars correspond very closely in physical and chemical properties to the ones obtained from the corresponding processes of destructive distillation, but with the former the yield is smaller since most of the tarry matter is consumed. The following approximate percentages of tar are obtained in ordinary producers designed to produce the *maximum* yield of gas, viz.:

Dry peat.....	1 -3%
Dry lignite (pure).....	4 -1%
Bituminous coal.....	3 -5%

Lignite carrying a *moderate* proportion of mineral matter (e.g. Messel lignite, p. 209) is treated in a special form of producer to obtain a small amount of gas and the largest possible yield of tar (4 to 14 per cent). This is brought about by introducing a *limited* and carefully regulated quantity of air and steam, sufficient only to support partial combustion. The same method is always followed in treating pyrobituminous shales, on account of the greater intrinsic value of the tar, of which 5 to 25 per cent is recovered. These processes approach destructive distillation very closely, the object being first to bring about incipient combustion of the lignite or shale and the non-condensable gases derived therefrom, thereby raising the temperature sufficiently to cause destructive distillation to ensue. It will thus become apparent that the yield of tar depends largely upon the quantities of steam and air introduced.

When peat, bituminous coal or lignite containing a *large* proportion of mineral matter is treated in a producer, it is always intended to produce the largest possible yield of gas, and the smallest proportion of tar.

PARTIAL COMBUSTION WITH A LIMITED ACCESS OF AIR

This process takes place in manufacturing generator gas, also upon smelting ores in blast-furnaces. No tar is produced in manufacturing generator gas, hence this process ceases to be of interest from the bituminologist's standpoint. In the case of blast-furnaces, no tar results when anthracite coal or coke is used as fuel, but when bituminous coal is used, as is sometimes the practice in England and on the Continent (see page 238), 2 to 3½ per cent of its weight of tar is produced. The air is forced into the blast-furnace from below, and travels upward through a comparatively thick layer of incandescent fuel. The oxygen on coming into contact with the fuel is first converted into carbon dioxide, which on rising through the incandescent layer combines with more carbon, forming carbon monoxide. The heat generated volatilizes a certain amount of the bituminous coal in the upper layers from which the tarry matters escape unconsumed.

CRACKING OF OIL VAPORS

In manufacturing oil-gas, crude petroleum or a heavy distillate known as "gas-oil" is sprayed under more or less pressure into a closed retort heated to redness. This causes the oil to decompose into a permanent gas and from 5 to 10 per cent by weight of oil-gas tar (see page 260). The reaction, known as "cracking," results in the breaking down of the hydrocarbons present in the petroleum or gas oil into simpler substances.

Water-gas is produced by the combustion of anthracite coal or coke in an atmosphere of steam (page 256) according to the following reaction:

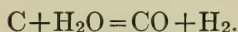

The gas consists theoretically of equal volumes of carbon monoxide and hydrogen. It burns with a non-luminous flame, and when intended for illuminating purposes must be enriched or "carburetted." The highly heated water-gas as it is generated, is accordingly mixed with a spray of crude petroleum or gas oil, then passed into a carburettor in which the oil becomes vaporized, and finally through a superheater maintained at a temperature sufficiently high to crack the oil vapors into permanent gases. From 2 to 10 per cent of tar is produced, based on the weight of the petroleum or gas-oil used. This tar is known as water-gas tar and is similar in its physical and chemical properties to oil-gas-tar (see page 262).

METHODS OF SEPARATING TAR

The vapors resulting from the foregoing pyrogenic processes are treated to remove the tar and aqueous liquor by one or more of the following devices:

- | | |
|---------------------------------|---|
| (1) Condensers..... | Mere cooling |
| (2) Static Scrubbers..... | } In contact with liquids |
| (3) Mechanical Scrubbers.... | |
| (4) Deflectors..... | } In contact with solids |
| (5) Filters..... | |
| (6) Electrical Precipitators... | In contact with an electrical discharge |

Each type will now be described separately:

(1) **Condensers.** The function of a condenser is to cool the hot vapors by circulation in a closed system of pipes surrounded by air or water. The following represent the most important types:

Hydraulic Main. This consists of a vertical metal pipe of liberal cross-section, cooled by the surrounding air. It is used in the manufacture of coal gas, oil

gas and coke (see pp. 230, 260). The vapors as they leave the retort are passed upward through the hydraulic main illustrated in Fig. 58, the top of which bends downward and dips into a closed trough partly filled with water, which acts as a seal and washes the vapors as they bubble through. This enables any retort being recharged or repaired, and at the same time prevents the vapors generated by the other retorts from escaping into the atmosphere. Most of the ammonia is dissolved in the water contained in the trough, and a large proportion of the tar condenses out.

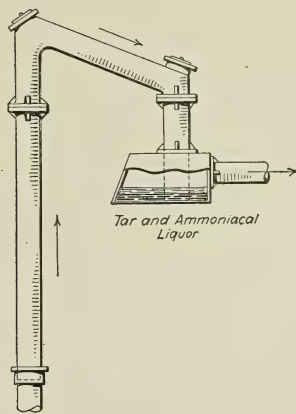

FIG. 58.—Hydraulic Main.

Air-condensers. These are illustrated in Fig. 59. The gases are circulated through vertical pipes alternately connected at the top, and leading into a closed chamber below separated by partitions through which water is slowly allowed to circulate, which catches the tar and ammonia.

Water-condensers. In these the vapors are passed through a series of pipes around which water is allowed to circulate, as illustrated in Fig. 60. The cooling water from one compartment is passed through the next, in such a manner that the vapors and water travel in opposite directions. The ammoniacal liquor and the tar separate out at the bottom. In manufacturing coal gas, the vapors after they leave the hydraulic main, are passed through a device of this description, which serves to cool them to atmospheric temperature, and results in a more complete separation of tar, than is possible in the former.

(2) **Static Scrubbers.** Static scrubbers are stationary contrivances through which water is caused to circulate. They are classified into: rain, hurdle and baffle scrubbers.

Rain Scrubbers. Consist of closed chambers into which the gas is introduced at the bottom and washed with jets of water impinging against screens which serve to break them into a fine spray, illustrated in Fig. 61. This represents the simplest form of static scrubber and has been superseded by more efficient types, due to the very short time of contact between the vapors and the water. They are excessively large and expensive to operate, and there are apt to be "dead corners" as the gases rush through.

Hurdle Scrubbers. These are built in the form of a tower whose height is usually four times its diameter, and separated into compartments by perforated

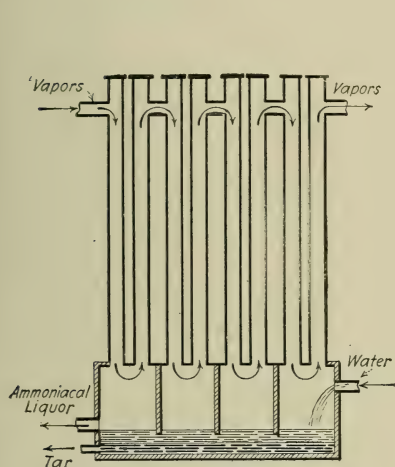

Fig. 59.—Air Condenser.

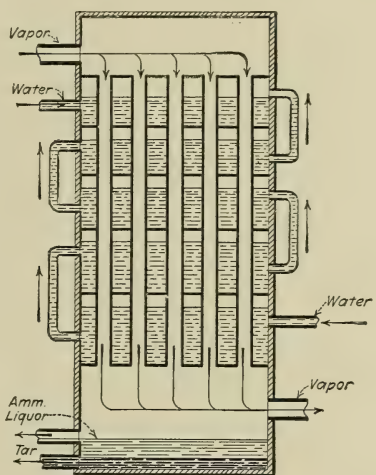

Fig. 60.—Water Condenser.

shelves carrying coke (Fig. 62), or in the case of the Zschocke scrubber, wooden slats stacked in alternate directions forming a checker work (Fig. 63). The function of the coke or wooden slats is to break up the jets of water introduced at the top and secure intimate contact with the vapors which pass in at the bottom and out at the top of the scrubber. The coke scrubber is open to the objection that the interstices of the coke become clogged with tar, and thus soon loses its efficiency.

Baffle Scrubbers. These are constructed so the water is caused to flow from baffle to baffle in a zigzag direction, whereas the vapors pass upwards, as shown in Fig. 64. This brings the vapors into contact with a large surface of moving water, and at the same time prevents the formation of dead pockets as is the case with some of the foregoing types.

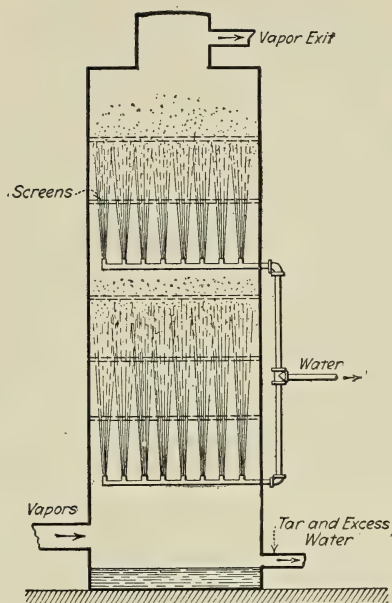

FIG. 61.—Rain Scrubber.

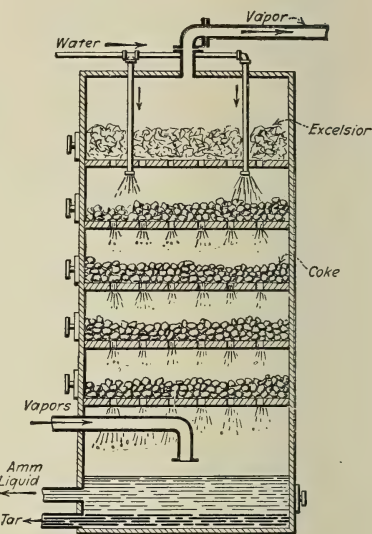

FIG. 62.—Hurdle Scrubber Filled with Coke.

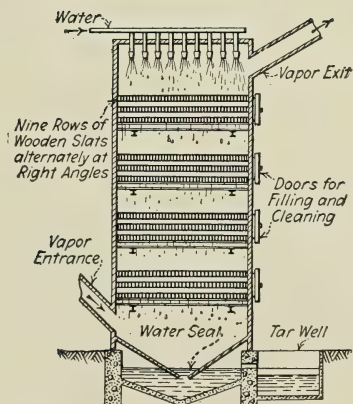

FIG. 63.—Hurdle Scrubber Filled with Wooden Slats.

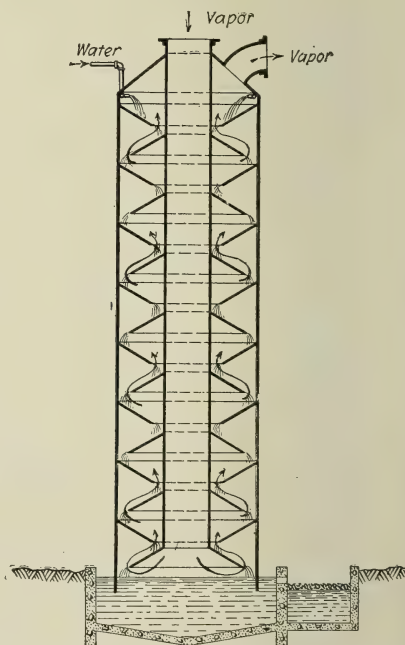

FIG. 64.—Baffle Scrubber.

(3) **Mechanical Scrubbers.** In this type part of the mechanism is caused to revolve, and thus thoroughly comingle the water with the vapors. They include the following:

Feld Centrifugal Scrubber. The "Feld Centrifugal Scrubber" as illustrated in Fig. 65, is composed of a number of superimposed chambers, each provided with a plurality of gas ports (*a*), and a series of inverted hollow, frustums of cones (*b*) mounted on a central vertical shaft, the outer cone having its top covered. The washing liquor enters at the top and overflows from chamber to chamber, part being drawn off from each chamber. The lower edges of the cones dip into the liquid, and being revolved at a high speed, carry it up along the inner surfaces, to be hurled off tangentially in a fine spray through perforations near the top of the outer cone. A perforated plate (*c*) mounted on the shaft in the dome, serves to separate any liquid entrained with the vapors leaving the washer. This

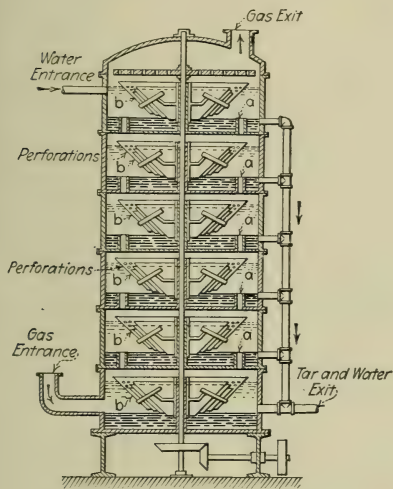

FIG. 65.—Feld Centrifugal Scrubber

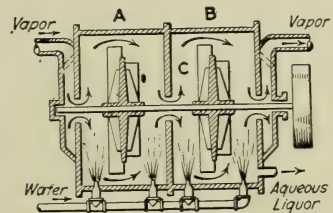

FIG. 66.—Reading Centrifugal Scrubber.

type is very efficient and economical, and forms the basis of the Feld system for fractioning coal tar. (See p. 249.)

Reading Centrifugal Scrubber. The Reading centrifugal scrubber, illustrated in Fig. 66, consists of two connecting compartments (*A* and *B*) separated by a disc (*C*). Each compartment carries a set of rapidly revolving blades mounted on a horizontal shaft. Water is introduced through the casing at the bottom and churned into a spray. The vapors are thrown against the casing wall by centrifugal force, and any particles of tar or dust retained by the liquid. After the vapors are treated in chamber (*A*) they flow through an opening near the centre of the disc into chamber (*B*), where they are treated in a similar manner, whereupon the cleansed vapors are drawn off through an aperture surrounding the shaft.

Thiesen Centrifugal Scrubber. This consists of a rapidly revolving cylindrical drum, carrying on its periphery an oblique spiral vane, almost touching the sur-

rounding casing lined with wire netting, which serves to retain water in its meshes by capillarity. This washer is illustrated in Fig. 67. The vapors enter at (a) and are drawn through the spiral channel (b) where they commingle with water sprayed through the tangential openings (c). The vapors pass out through the pipe (d), and the cleaning liquid at (e). The vapors are rapidly and thoroughly washed with comparatively little expenditure of power.

Schwarz-Bayer Disintegrator. This is composed of a series of blades or vanes fastened concentrically to a cylindrical frame-work and revolving alternately in opposite directions (Fig. 68). The washing water, entering at (A), is broken up into a fine mist by the rapidly revolving vanes, and finally passes out at (B). The vapors are introduced at the circumference (C), being drawn off at the centre of the casing through (DD).

(4) **Deflectors.** No water is employed in this type of apparatus, which is generally used to supplement the scrubbers, and remove the

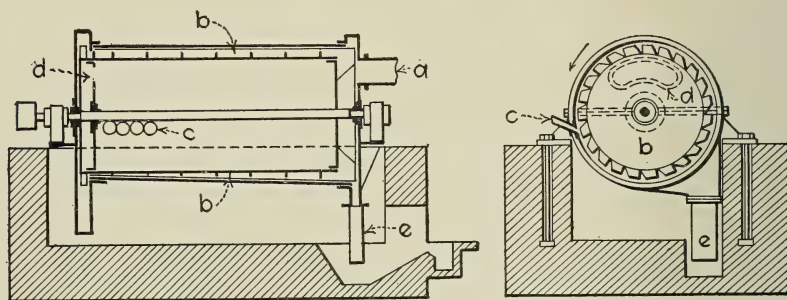

FIG. 67.—Thiesen Centrifugal Scrubber.

last traces of tar from the vapors. They operate on the principle that when a rapidly moving stream of vapor impinges against an obstruction, which changes the direction of flow, the suspended tar is caused to condense.

P. & A. Tar Extractor. This constitutes one of the best known deflectors. It is popularly called the "P. & A. Type," after the inventors, Messrs. Pelouze and Audouin, and is illustrated in Fig. 69. The vapors are caused to flow through narrow apertures in a series of perforated metal cylinders mounted concentrically so that the apertures in one cylinder fall opposite the solid portions of the adjacent cylinders. The vapors are thus caused to assume a zig-zag travel, and their direction changed many times. This causes the tar to precipitate out, and collect at the bottom of the extractor, where it is drawn off. By the chain and weights, the cylinders rise or fall in the liquid, exposing a greater or lesser surface as the volume of vapors increases or decreases.

Centrifugal Deflector. This is illustrated in Fig. 70, and consists of two compartments (1) and (2), connected by the orifice (3). The vapors enter at (4) and their velocity forces them tangentially against the inner surface of compartment (1), imparting a whirling motion to the current. When the vapors enter

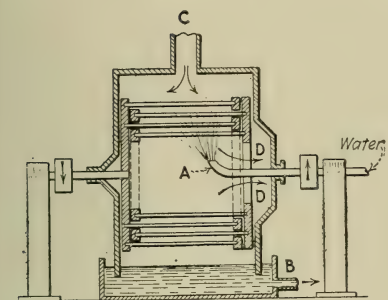

FIG. 68.—Schwarz-Bayer Disintegrator.

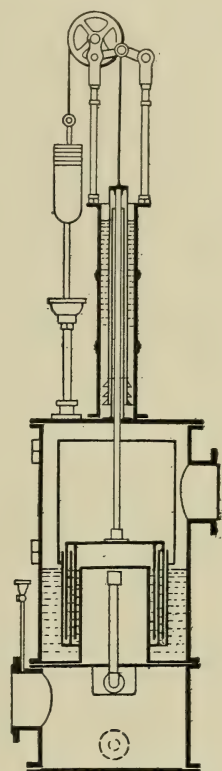

FIG. 69.—P. & A. Tar Extractor.

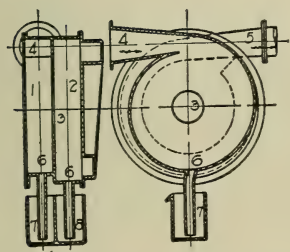

FIG. 70.—Centrifugal Deflector.

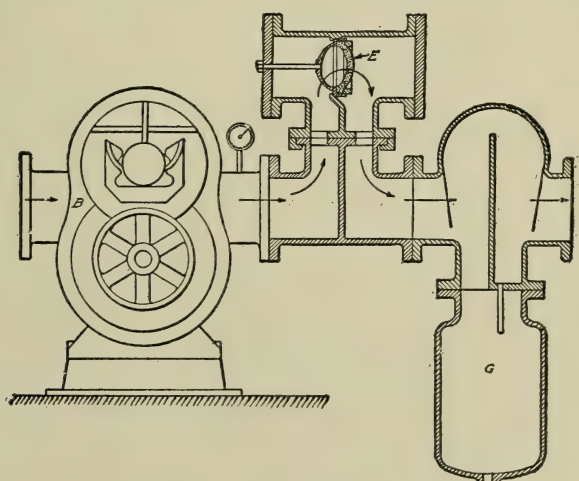

FIG. 71.—Smith Tar Extractor.

compartment (2) they are caused to whirl in the opposite direction and leave at (5). The rapid change in motion coupled with centrifugal force causes the tar to separate and flow into the sumps (7) and (8).

(5) **Filters.** *Smith Tar Extractor.* This represents the most successful type of filter, and is illustrated in Fig. 71. The pump (B) forces the vapors through a porous diaphragm (E), about $\frac{1}{4}$ in. thick composed of spun glass-wool, supported between two metal screens. No tar is retained in the diaphragm, but in passing through, the fog coalesces into larger globules which on account of their greater size and weight can no longer be carried forward by the gas current, and accordingly settle out into a sump (G), whence it is drawn off from time to time. This extractor operates to best advantage on tars containing little to no free carbon. The temperature should be sufficient to maintain the tar in a liquid condition, and the pressure maintained at $2\frac{1}{2}$ to 4 lbs. Since no water is employed, the separated tar contains less than 1 per cent, which is a decided advantage, and in addition practically every vestige of tar is removed from the vapors.

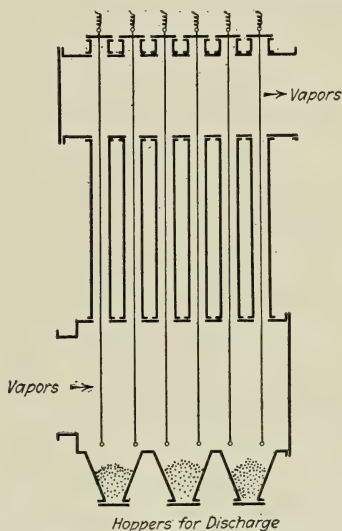

FIG. 72.—Cottrell Electrical Precipitator.

15,000 to 50,000 volts, in the type of apparatus illustrated in Fig. 72. This method has also been described by Steers and others.¹ The electrical current effectively breaks up tar fogs, but up to the present time the method has only been used in a limited way.

(6) **Electrical Precipitators.** *Cottrell System.* This consists in subjecting the vapors to a "silent" or "glow" unidirectional electrical discharge of from

METHODS OF DEHYDRATING TAR

The tar separated from most of the foregoing processes carries more or less water, derived from the liquor normally associated with the tar vapors, as well as any water introduced in the condensers, static and mechanical scrubbers, for cooling or cleansing purposes. When a large

¹ *J. Soc. Chem. Ind.*, **33**, 1145, 1914.

amount of extraneous water is mixed with the tar, most of it is first allowed to settle out by gravity described in methods (1) and (2) below.

The following devices are used for dehydrating tars:

(1) **Settling Tanks.** The oldest method consists in storing the tar in large metal or masonry tanks for the double purpose of keeping a sufficient supply of tar on hand to enable the works to operate continuously, and also to allow as much as possible of the entrained aqueous liquor to separate out. The liquor being of a lower density than the tar, rises to the surface, whence it is drawn off through a series of small outlet cocks on the side. If the tar is sufficiently fluid, a prolonged standing will allow much of the aqueous liquid to separate at ordinary temperatures. On the other hand if the tar is viscous, the process can be facilitated by maintaining the tar at a moderate temperature by means of steam coils at the bottom of the tank. The latter are of special importance in winter time, when the tar is very apt to decrease in fluidity. Gas-works tars treated in this manner still carry between 4 and 10 per cent of water, coke-oven tars between 3 and 6 per cent and water-gas tars up to 40 per cent.

(2) **Baffle-plate Separator.** This apparatus is used for the continuous separation of tar from the large quantity of washing water introduced in the condensers, static and mechanical scrubbers [methods (2) and (3), (pp. 175, 77).] The separator is illustrated diagrammatically in Fig. 73. The baffle plates (A) run from the top down to within a foot of the bottom and alternating with these are dams (B) extending from within 4 in. of the bottom to within 4 in. of the water line. The path of the water and tar is under the baffle plates and over the dams, thus giving the latter an opportunity to settle out, and incidentally form a seal for the dams. The speed of flow is regulated so that the effluent is practically clear water, the tar being drawn off automatically through a syphon when it reaches the proper level.

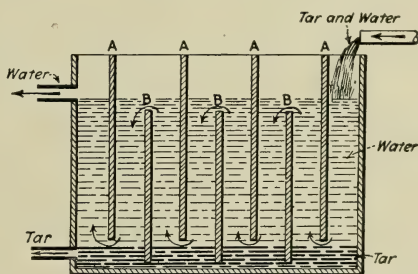

FIG. 73.—Baffle-Plate Tar Separator.

(3) **Heating Quietly under Pressure.** Refractory tars can very often be dehydrated by heating under pressure in a closed boiler. As the temperature rises, the fluidity of the tar increases, enabling it to settle out more or less readily. The process is intermittent, and is not universally applicable.

(4) **Wilton Process.** This is a continuous process in which the tar is heated to 170 to 180° C. at a pressure of about 30 lbs. per square inch. The temperature of the tar is regulated by the speed with which it is pumped through a coil in a furnace heated by coke. It is then released into a vapor-chamber at atmospheric pressure, whereupon the water and the light oils speedily evaporate, since they are maintained at a temperature considerably higher than their boiling-points. This is accompanied by copious frothing in consequence of the fact that each volume of water at its boiling-point (100° C.) becomes converted into 1640 volumes of steam. The resulting vapors are condensed to recover the light oils. The dehydrated tar is passed through an economizer which utilizes the heat in preheating the crude tar.¹

(5) **Heating a Thin Stream under Vacuum.** This is also a continuous process and one of the most successful ones for dehydrating tars. The crude tar is allowed to flow to a thin stream over steam coils or heated baffle-plates in a closed vessel maintained under a moderate vacuum. The tar is allowed to run into the vessel, and then removed by a pump which at the same time maintains the vacuum. The vapors are condensed to recover the light oil. An apparatus of this kind will treat about 50,000 gallons of tar in 24 hours reducing the water to less than 0.5 per cent.²

(6) **Centrifugal Method.** This method is also continuous, and has been used with more or less success abroad. The tar is first heated to a

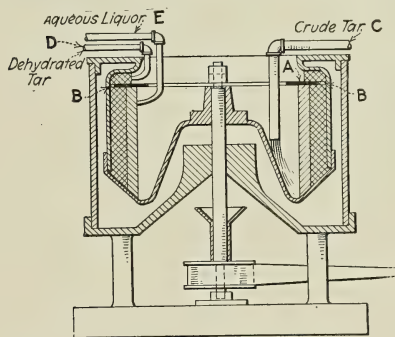

FIG. 74.—Centrifugal Tar Dehydrator.

temperature of 40 to 50° C. and run into the rapidly revolving drum of a centrifugal separator, illustrated in Fig. 74. The tar being heavier than the water is forced to the periphery, the water forming a cylindrical layer inside. An annular diaphragm (A) attached to the upper part of the centrifugal has a ring of perforations where it comes in contact with the drum at (B). The crude tar is introduced through the pipe (C) below the diaphragm. The speed with which

the drum revolves causes the tar to flow through the perforations into the upper portion of the centrifugal, where it is removed through the

¹ C. H. Webb, *Eng. News*, **68**, 109, 1912; *J. Gas Lighting*, **124**, 505, 1913; *Gas World*, **59**, 626, 1913; E. V. Chambers, *Am. Gas Light J.*, **103**, 389, 1916; A. E. Mottram, *Gas J.*, **137**, 464, 1917.

² R. P. Perry, 8th Intern. Cong. Applied Chem., **10**, 242, 1912.

pipe (*D*). The water is drawn off through (*E*) below the diaphragm, which bars its passage into the upper section. This method is particularly suited for treating tars having approximately the same specific gravity as water, as for example water-gas tar. The centrifugal is revolved at a speed between 2000 and 3000 revolutions per minute. Tars containing between 30 and 90 per cent of water will have the percentage reduced to less than 1 per cent in one treatment. A large portion of the free carbon contained in the tars is also removed, and affixes itself to the inner walls of the drum from which it must be scraped occasionally.¹

(7) **Electrical Method.** This method has only been worked out experimentally, and consists in passing the tar between electrodes charged with a high potential current. This causes the particles of water to coalesce, so that they will separate out readily on subjecting the tar to a temperature of 80° C.²

(8) **Feld System of Fractional Cooling.** This process also results in the production of dehydrated products. The method will be described in detail on page 249.

¹ *Am. Gas Light J.*, **102**, 349, 1915.

² U. S. Pats. 1,116,299, Nov. 3, 1914; 1,142,759, 1,142,760, and 1,142,761 of June 8, 1915, all to R. E. Laird and J. H. Raney.

CHAPTER XIV

WOOD TAR, WOOD-TAR PITCH AND ROSIN PITCH

WOOD TAR AND WOOD-TAR PITCH

THIS chapter will deal with the treatment of wood, either by destructive distillation, or by a combination of steam and destructive distillation.¹ The treatment of resinous woods by the steam distillation process alone, for the recovery of turpentine and other oils, does not fall within the scope of the present treatise.

Varieties of Wood Used. From the standpoint of destructive distillation, woods may be divided into two classes, viz.:

Hard Woods, including the maple, birch, beech, oak, poplar, elm, willow, aspen, alder, ash, hickory, chestnut and eucalyptus.

Resinous or Soft Woods, including the pine, fir, cedar, cypress, spruce, hemlock, larch or tamarack.

The trees from which hard woods are obtained are known as "broad-leaved" or "deciduous trees," and those producing resinous- or soft-woods are termed "coniferous trees" or "evergreens." Soft woods are distinguished from hard woods principally in that the former contain larger quantities of turpentine and resin. The distillation of hard wood aims at the recovery of wood alcohol, acetates, tar and charcoal, whereas the distillation of resinous wood (soft wood) is directed to the recovery of turpentine, wood oils, tar and charcoal.

In the wood-distilling industry the basis of measurement is a cord, which is taken to equal 90 cu. ft. of the closely stacked wood containing 15 per cent of moisture. The weight of a cord varies with different kinds of wood, from about 1700 lbs. in the case of white pine and poplar, to about 4000 lbs. in the case of oak.

¹"Chemical Methods of Utilizing Wood," by F. P. Veitch, Circular 36, U. S. Dept. Agr., Bureau of Chem., Wash., D. C., Aug. 29, 1907; "Wood Used for Distillation in 1906," Forest Service Circular No. 121, U. S. Dept. Agr., Wash., D. C., Dec. 6, 1907; "Wood Distillation," by W. C. Geer, Forest Service Circular No. 14, U. S. Dept. Agr., Wash., D. C., Nov. 5, 1907; "Wood Turpentine, Its Production, Refining, Properties and Uses," Circular No. 144, U. S. Dept. Agr., Bureau of Chemistry, Wash., D. C., 1912; "Yields from the Destructive Distillation of Certain Hardwoods," by Hawley and Palmer, Bull. No. 129, U. S. Dept. Agr., Wash., D. C., Sept. 10, 1914; "Yields from the Destructive Distillation of Certain Hardwoods," by R. C. Palmer, Bull. No. 508, U. S. Dept. Agr., Wash., D. C., March 6, 1917; "The Distillation of Wood," by J. C. Lawrence, *J. Soc. Chem. Ind.*, 5T., 37, 1918; "The Influence of Moisture on the Yield of Products in the Destructive Distillation of Hardwood," by R. C. Palmer and H. Cloukey, *J. Ind. Chem.*, 10, 262, 1918.

For purposes of destructive distillation, the wood should be as dry as possible, as during the process all the moisture must be evaporated before the wood decomposes. The smaller the percentage of moisture contained in the wood, the more rapid the distillation process and the smaller the quantity of fuel required. It is advisable therefore, to cut and stack the green wood containing 20 to 50 per cent of moisture from 6 months to 2 years, during which the moisture content will fall to between 12 and 25 per cent.

Yields of Distillation. The following figures will give a general idea of the average yields upon distilling a cord of the respective classes of wood.

	Hard Woods.	Soft (Resinous) Woods.
Turpentine.....	0	5-25 Gals.*
Wood oils.....	0	30-75 Gals.
Crude alcohol (containing acetone).....	8- 12 Gals.	2- 4 Gals.
Tar.....	8- 20 Gals.	30-60 Gals.
Charcoal.....	40- 52 Bu.	25 -40 Bu..
Acetate of lime.....	150-356 lbs.	50-100 Lbs.

* Saw-dust yields 5 to 10 gals. of turpentine and light wood 10 to 25 gals. per cord.

Hard-Wood Distillation. The following figures show the yields of tar and charcoal from the various hard woods in percentage, based on the dry weight of the material:¹

	Tar, Per Cent.	Charcoal, Per Cent.
Hickory.....	13.0	37.7
Maple.....	12.8	40.6
Birch.....	12.0	40.6
Beech.....	9.4	41.9
Oak.....	7.8	45.7
Chestnut.....	4.6	47.6

In the United States, the principal centres for hard wood distillation are in the States of Pennsylvania, New York and Michigan. Soft wood distillation is carried on largely in the States of Florida, Georgia, North and South Carolina and Alabama.

The crude products of the distillation of hard wood may be grouped into four classes, viz.:

- (1) Non-condensable gases..... 20-30%
- (2) Aqueous distillate (crude pyroligneous acid)..... 30-50%
- (3) Turpentine, wood oils, and wood tar..... 5-20%
- (4) Charcoal..... 20-45%

¹ See also Table 5, p. 7, Bull. 508, U. S. Dept. Agriculture, Wash., D. C., March 6, 1917.

When hard wood is heated in a retort, water passes off below 150°C . after which decomposition sets in. With soft (resinous) wood, turpentine and water commence to distil between 90 and 100°C . and continue to 150°C ., whereupon products of destructive distillation pass over. The distillation process is practically complete at 430°C . In the case of hard wood, the first series of products which pass over (between 150 to 280°C .) include acetic acid, methyl alcohol and wood creosote; the second series (280 to 350°C .) consist of non-condensable gases (about 53 per cent of carbon dioxide, 38 per cent of carbon monoxide, 6 per cent

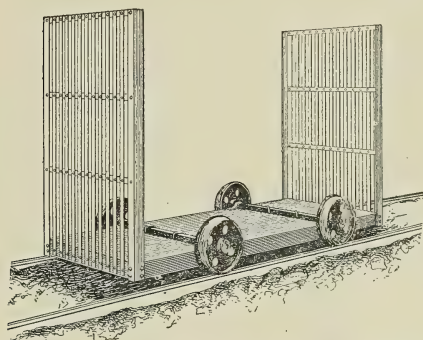

FIG. 75.—Iron Cars Used in the Distillation of Hardwood.

of methane, 3 per cent of nitrogen, etc.); the third series (350 to 400°C .) are composed of solid hydrocarbons and their derivatives. The yields of methyl alcohol and acetic acid increase with a rise of temperature up to 300°C . beyond which they decrease, and moreover the recovery is greater when the wood is heated slowly, than when the distillation is forced.

In distilling hard woods large rectangular iron retorts are used, measuring 6 ft. in width, 7 ft.

high and either 27 or 50 ft. long, depending upon whether they are intended to hold 2 or 4 carloads. The retorts are set in brick work, and provided with large air-tight iron doors at the ends. The wood is loaded on small iron cars holding between 1 and 3 cords each (Fig. 75) which are run on tracks directly into the retorts.

The arrangement of a modern wood-distilling plant is shown in Fig. 76; where *A* represents a car; *B*, the retort; *C*, first cooler; *D*, second cooler; *E*, the acetate drying floor; *a*, condensers; *b*, liquor trough; *c*, gas main to boilers; *i*, fuel conveyor; *m*, fire-place; *n*, ash pit; *o*, hinged spout to deliver fuel from *i* to *m*. After the retort is charged, the doors are closed and heat applied slowly, either by burning the non-condensable gases resulting from the distillation process, or by atomizing the tar underneath the retort with a jet of steam. Unless the gases are stored in a gas-holder, the process is started by burning a small amount of wood on an auxiliary grate beneath the retort.

The vapors from the retort is passed through condensers, where the pyroigneous acid, alcohol and other condensable constituents are recov-

ered. These are conveyed to large settling tanks, and allowed to rest quietly until the tar settles out.

The distillation process continues from 20 to 30 hours, whereupon the fires are extinguished and the retort allowed to cool. The small

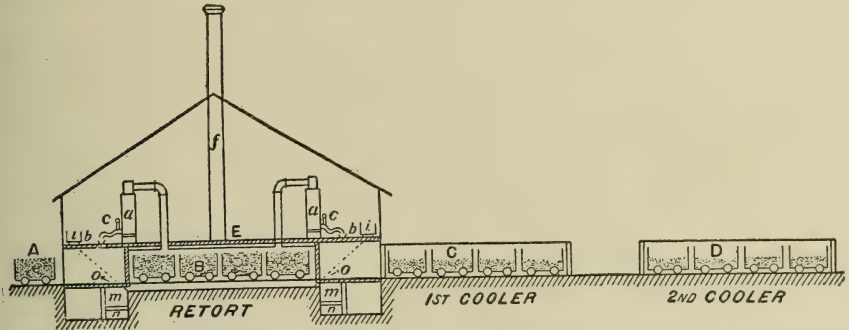

FIG. 76.—Modern Wood Distilling Plant.

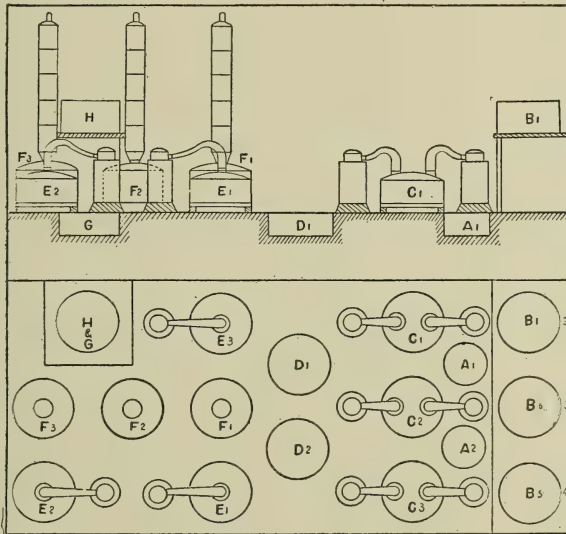

FIG. 77.—Plant for Refining Wood Tar.

iron cars now carrying charcoal are quickly run from the retort into large iron coolers, similar in size and shape to the retort itself, and the doors are closed to prevent access of air.

The general arrangement of a refining plant is shown in Fig. 77, where A 1-2 represents the raw liquor vats, B 1-6 represent the raw liquor settling tanks, C 1 the tar still, C 2-3 the raw liquor still, D 1-2

the neutralizing vat, E 1-3 the lime-lee stills, F 1-3 the alcohol stills, G the weak alcohol storage tank and H the strong alcohol storage tank. Table XVI shows a diagrammatic outline of the products obtained upon distilling hard wood, and refining its distillates.

TABLE XVI

HARD WOOD

Distilled Destructively

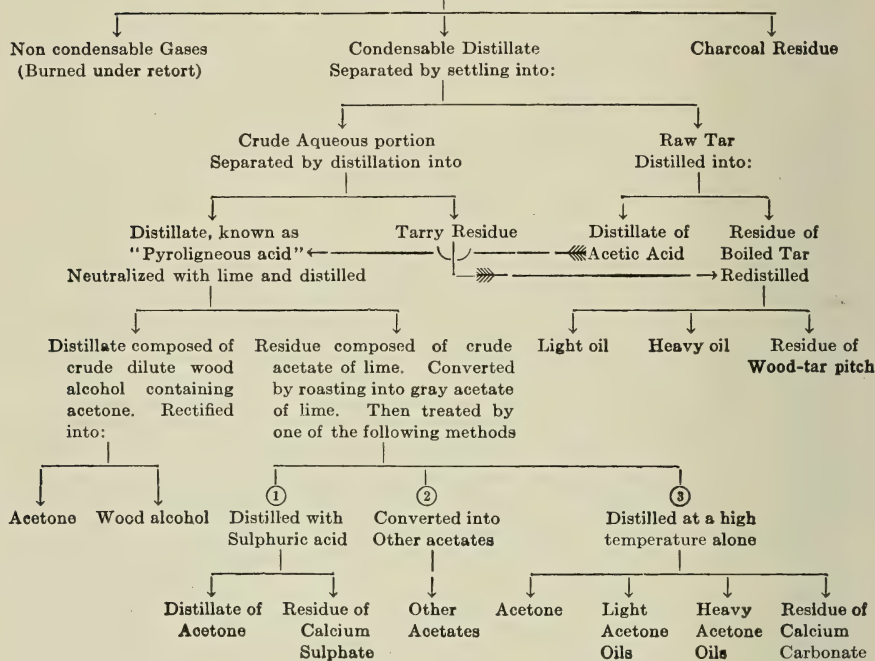

After the pyroligneous acid and tar have been separated by settling, the crude products are distilled independently to recover any pyroligneous acid from the crude tar, and conversely, any tar retained by the crude pyroligneous acid (dissolved in the alcohol and acetone present). The dehydrated tar, known as "boiled tar" or "retort tar," amounting to between 3 and 10 per cent of the weight of the wood, may be utilized in one of the following ways:

- (1) It may be sold as such, and used for preserving wood.
- (2) It may be burned under the retorts as fuel.

(3) It may be subjected to fractional distillation to recover the light oils boiling below 150° C., heavy oils boiling between 150 and 240° C., and the residual pitch constituting between 50 and 65 per cent by

weight of the tar. The light oils are used as solvents in manufacturing varnish, and the heavy oils after further refining are marketed as commercial wood creosote which finds a sphere of usefulness as a disinfectant, preservative, and flotation oil (p. 455).

The combined liquors containing acetic acid, methyl alcohol, and acetone are neutralized with lime, and re-distilled in the "lime-lee still." In this manner, the alcohol, acetone and ketones pass over, whereas the acetic acid remains in the still combined with the lime (calcium acetate) and contaminated with a small proportion of tarry matter. The residue containing from 65 to 75 per cent of pure acetate of lime is known commercially as "brown acetate of lime." The distillate is fractionated in a column still to separate the pure wood alcohol and acetone from the water and other impurities present (ketones, etc.).

Brown acetate of lime is first roasted at 230° C. to decompose any tarry matters. It may then be distilled with sulphuric acid to produce commercial acetic acid, which is recovered as distillate; or it may be converted into aluminium, chromium, copper, lead or sodium acetate; or it may otherwise be distilled alone in an iron retort, whereupon acetone is first obtained, and followed at 400° C. by the "acetone oils" (light acetone oil boils between 75 and 130° C., and heavy acetone oil between 130 and 250° C.).

Soft (Resinous) Wood Distillation. In treating soft wood (resinous wood) a different method is followed. Iron or steel retorts varying in capacity from one to four cords are used, constructed either vertically or horizontally, as shown in Fig. 78. Low-pressure superheated steam, or saturated steam under high pressure is introduced into the retort to remove the turpentine, and then the volatile oils (known as "heavy oils"), leaving a residue of coke behind. Three classes of resinous wood are used for the purpose:

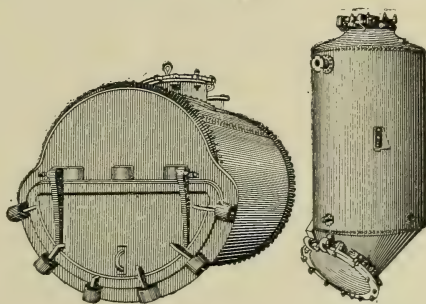

FIG. 78.—Retorts for Distilling Soft Wood.

(1) "Light wood" containing comparatively large quantities of turpentine.

(2) "Stumps" which also contain more or less turpentine.

(3) Saw-mill waste which is rather poor in turpentine.

The wood is first "hogged," or in other words cut into chips before it is introduced into the retort. The temperature is raised gradually to 200° C. as the steam passes through the retort. Water and crude turpentine distil over first and are separated by settling. As the tempera-

ture rises above 200 to 220° C. the wood commences to decompose into tarry substances, and at about 250° C. the resins present break up into "rosin spirits" and "rosin oils." Both the crude turpentine and the heavy oils are redistilled separately, the former producing purified wood turpentine and the latter pine oil, rosin oil and pitch. Rosin spirits boils between 80 and 200° C., pine oil between 190 and 240° C., and rosin oil between 225 and 400° C.

In some cases the light wood is subjected to a process of destructive distillation without using steam. The temperature is raised slowly and the distillate under 200° C. caught separately to avoid contamination with tarry matters. After the temperature rises above 200° C., the process follows the same course as for hard-wood distillation. The distillate under 200° C. is fractionated into light and heavy oils respectively. The light oil is in turn redistilled to recover the rosin spirits, wood turpentine and a part of the pine oil. The heavy oil is similarly redistilled to separate the pine oil, rosin oil and a part of the pitch. The crude tar obtained above 200° C. is distilled to recover any acetic acid, and the residue either marketed as "pine tar" or distilled to separate the light and heavy oils from the pine-tar pitch obtained as residue. This process is illustrated diagrammatically in Table XVII.

TABLE XVII

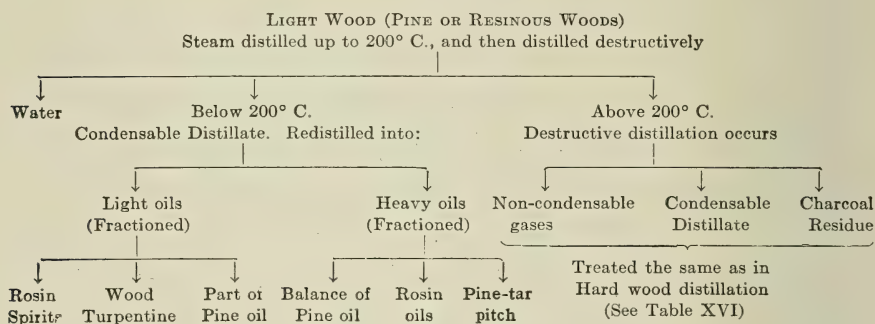

Pine tar is also marketed under the name "Stockholm tar," and contains a certain proportion of rosin.

Wood Tars. The bituminous products derived from the destructive distillation of wood are designated commercially as hard-wood tar, pine tar, hard-wood-tar pitch and pine-tar pitch.

The physical and chemical characteristics of the tars and corresponding pitches vary, depending upon the kind of wood used, as well as the exact method of treatment. The following figures will give a general

idea of the characteristics of the dehydrated hard-wood tar and pine tar ordinarily encountered in the American market:

	<i>Hard-wood Tar</i>	<i>Pine tar (from Resinous Woods)</i>
(Test 1) Color in mass.....	Black	Brownish
(Test 7) Specific gravity at 77° F.....	1.10-1.20	1.05-1.10
(Test 8) Viscosity.....	Fairly liquid	Viscous
(Test 9) Consistency at 77° F.....	Liquid	Liquid
(Test 13) Odor on heating.....	Characteristic	Characteristic
(Test 15) Fusing-point.....	Below 20° F.	Below 50° F.
(Test 16) Volatile matter at 500° F., 4 hrs.....	35-60%	40-75%
(Test 17a) Flash-point.....	50-75° F.	60-90° F.
(Test 19) Fixed carbon.....	5-20%	5-15%
(Test 21a) Solubility in carbon disulphide.....	95-100%	98-100%
(Test 21b) Non-mineral matter insoluble.....	0-5%	0-2%
(Test 21c) Mineral matter.....	0-1%	0-1%
(Test 22) Carbenes.....	0-2%	0-2%
(Test 23) Solubility in 88° naphtha.....	50-90%	65-95%
(Test 24) Solubility in absolute alcohol.....	Almost complete	Almost complete
Solubility in glacial acetic acid.....	Almost complete	Almost complete
Solubility in acetic anhydride.....	Almost complete	Almost complete
(Test 28) Sulphur.....	0.0%	0.0%
(Test 30) Oxygen.....	2-10%	5-10%
(Test 32) Naphthalene.....	None	None
(Test 33) Paraffine.....	None	None
(Test 35) Sulphonation residue.....	Trace to 5%	Trace to 5%
(Test 37) Saponifiable constituents.....	5-25%	10-50%
(Test 37a) Resin acids.....	Up to 15%	Up to 30%
(Test 41) Diazo reaction.....	Yes	Yes
(Test 42) Anthraquinone reaction.....	No	No
(Test 43) Liebermann-Storch reaction.....	Yes	Yes

According to Holde,¹ on shaking wood tar with water, the aqueous extract will react acid (due to the acetic acid present), and upon adding a few drops of ferric chloride, will at first form a green and then a brownish-green coloration. On subjecting wood tar to distillation, the first portion passing over shows a separation of water which will react acid. On continuing the distillation, oily matters are obtained dissolving readily in alcohol, and which on treatment with concentrated sulphuric acid become converted into water-soluble substances. Pine tar has a high acid value, since it often contains as much as 30 per cent by weight of resin acids.

Wood-tar Pitches.—Hard-wood-tar pitch and pine-tar pitch vary in their physical properties, depending upon the following circumstances:

(1) The variety of wood used.

(2) The method by which the wood is distilled, including the temperature, its duration, the kind of retort, etc.

(3) The extent to which the tar is distilled in producing the pitch. The further it is distilled, the harder the pitch and the higher its fusing-point.

They comply with the following characteristics:

¹ "Untersuchung der Kohlenwasserstofföle und Fette," p. 286. Berlin. 1913.

	<i>Hardwood-tar Pitch</i>	<i>Pine-tar Pitch (from Resinous Wood)</i>
(Test 1) Color in mass.....	Black	Brownish black
(Test 2) Homogeneity.....	Uniform	Uniform
(Test 4) Fracture.....	Conchoidal	Conchoidal
(Test 5) Lustre.....	Bright to dull	Bright to dull
(Test 6) Streak.....	Brown to black	Brown
(Test 7) Specific gravity at 77° F.....	1.20-1.30	1.10-1.15
(Test 9c) Consistency at 77° F.....	10-100	10-100
(Test 9d) Susceptibility factor.....	>100	>100
(Test 10) Ductility.....	Variable	Variable
(Test 13) Odor on heating.....	Characteristic	Characteristic
(Test 15a) Fusing-point (K. and S. method).....	100-200° F.	100-200° F.
(Test 16) Volatile matter.....	Variable	Variable
(Test 19) Fixed carbon.....	15-35%	10-25%
(Test 21a) Soluble in carbon disulphide.....	30-95%	40-95%
(Test 21b) Non-mineral matter insoluble.....	5-70%	2-60%
(Test 21c) Mineral matter.....	0-1%	0-1%
(Test 22) Carbenes.....	2-10%	0-5%
(Test 23) Solubility in 88° naphtha.....	15-50%	25-80%
(Test 28) Sulphur.....	0%	0%
(Test 30) Oxygen in non-mineral matter.....	1-5%	2-8%
(Test 32) Naphthalene.....	None	None
(Test 33) Paraffine.....	None	None
(Test 35) Sulphonation residue.....	0-5%	0-3%
(Test 37) Saponifiable constituents.....	5-25%	10-40%
(Test 37c) Resin acids.....	Up to 20%	Up to 40%
(Test 41) Diazo reaction.....	Yes	Yes
(Test 42) Anthraquinone reaction.....	No	No
(Test 43) Liebermann-Storch reaction.....	Yes	Yes

A representative sample of hardwood-tar pitch tested by the author showed:

(Test 9c) Hardness at 115° F.....	3.9
Hardness at 77° F.....	53.1
Hardness at 32° F.....	Greater than 150
(Test 9d) Susceptibility factor.....	Greater than 100
(Test 10b) Ductility at 115° F.....	41
Ductility at 77° F.....	50.5
Ductility at 32° F.....	0
(Test 11) Tensile strength at 115° F.....	0.3
Tensile strength at 77° F.....	2.1
Tensile strength at 32° F.....	12.0
(Test 15a) Fusing-point (K. and S. method).....	123° F.
(Test 21a) Soluble in carbon disulphide.....	62.7%
(Test 23) Soluble in 88° naphtha.....	25.3%

A sample of pine-tar pitch tested by Church and Weiss¹ showed:

(Test 7) Specific gravity at 77° F.....	1.13
(Test 9b) Penetration at 115° F.....	Too soft
Penetration at 77° F.....	41
Penetration at 32° F.....	3
(Test 15c) Fusing-point (cube method).....	127° F.
(Test 19) Fixed carbon.....	19.9%
(Test 21a) Soluble in carbon disulphide.....	95.4%
(Test 21b) Non-mineral matter insoluble.....	4.5%
(Test 21c) Mineral matter.....	0.1%
(Test 22) Carbenes.....	6.6%
(Test 24) Soluble in benzol.....	92.2%

¹ "Some Experiments on Technical Bitumens," *Proc. Am. Soc. Testing Materials*, **15**, 278, 1915.

According to Benson and Davis,¹ wood-tar pitches are more soluble in acetone than in carbon disulphide. Thus, hard-wood-tar pitches were found to be 15.6–31.9 per cent more soluble in acetone than in carbon disulphide, and pine-tar pitches (obtained from the Douglas fir) 8.0 to 57.8 per cent more soluble in the former solvent.

Wood-tar pitches are characterized by their extreme susceptibility to changes in temperature, by the fact that they appear hard and at the same time show a surprisingly low fusing-point.² Wood-tar pitches are notoriously non-weatherproof. They are extremely susceptible to oxidation on exposure to the weather and soon converted into a lifeless and pulverent mass. Pine-tar pitch contains more or less resin, and according to Holde, shows an acid value greater than 57.

ROSIN PITCH

The sap of the long-leaf pine, known chemically as an oleo-resin, is composed of a mixture of spirits of turpentine and rosin. It is gathered by cutting into the bark one-half to one inch, whereupon the oleo-resin slowly exudes and is collected in small cups, of which various types are in use.

The oleo-resin is then distilled to separate the spirits of turpentine from the rosin. The apparatus ordinarily used in the United States

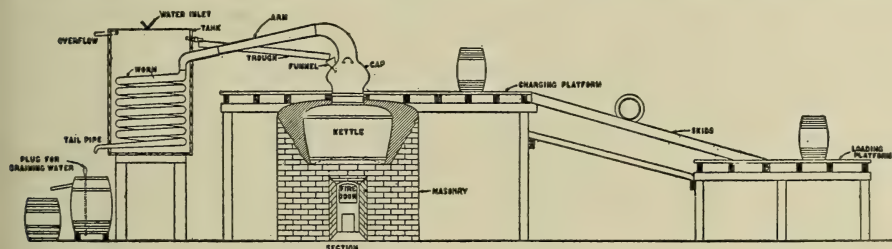

FIG. 79.—Retort for Distilling Rosin.

for this purpose is shown in Fig. 79, consisting of a simple type of copper still with a "worm" condenser. The capacity of the still varies from 10 to 40 barrels at the outside, and usually between 15 and 20. After the still is charged, the fire is started, and a mixture of spirits of turpentine and water (since the oleo-resin contains between 5 and 10 per cent

¹"The Free Carbon of Wood-tar Pitches," *J. Ind. Eng. Chem.*, **9**, 141, 1917.

²"Examination of Asphalts," by E. Donath and B. M. Margosches, *Chem. Ind.*, **27**, 220, 1904; "Behavior of Wood-tar Pitch with Certain Organic Solvents," B. M. Margosches, *Chem. Rev. Fett-Harz-Ind.*, **12**, 5, 1905; "Distinction between Lignite Pitch and Other Pitches," by E. Graefe, *Chem. Zeit.*, **30**, 298, 1906.

of water) appears in the condenser. When all the water has boiled over, additional quantities are added in a small stream during the distillation, since the introduction of water causes the turpentine to boil at a lower temperature and prevents overheating, improving both the colors and yields of the turpentine and rosin. Towards the end of the distillation the stream of water is shut off, and the rosin heated until all the moisture is expelled, usually between 300 and 400° F. Before cooling, any foreign matter is skimmed off the surface of the rosin, after which it is strained through a fine mesh screen and barreled.¹

Rosin deprived of its turpentine, when heated in a closed retort will undergo destructive distillation, yielding a gas, an aqueous liquor and an oily distillate which may be separated into several fractions. If the process is carried to completion, coke will be left as residue. If the distillation is terminated before the formation of coke, a pitchy residue will remain, known commercially as "rosin pitch."

The rosin may be distilled either with or without superheated steam. If the latter is employed, the quality of the distillate is improved, and a much better temperature control obtained. Distillation under vacuum is also used in many cases. The rosin may accordingly be destructively distilled by any of the following processes:

- (1) At atmospheric pressure without steam.
- (2) With superheated steam.
- (3) Under vacuum.

When the temperature of the rosin reaches 150° C. a liquid distillate appears which separates into two layers, the lower containing acetic acid, also other organic acids dissolved in water, and the upper composed of oily substances known as "rosin spirit" or "pinoline." When the temperature reaches 200° C. the receiver is changed, and the distillate which ensues is either collected together or separated into fractions. The temperature of the residue in the retort is permitted to reach 350 to 360° C. but never to exceed the latter. The fraction between 200 and 360° C. known as "rosin oil," may be separated into various portions termed "yellow rosin oil," "blue rosin oil," "green rosin oil," etc., depending upon their respective colors.

In distilling rosin destructively at atmospheric pressure, the following products are separated:

Non-condensable gases.....	9.0%
Acid liquor.....	3.5%
Rosin spirits or pinoline.....	3.5%
Rosin oil.....	67.0%
Rosin pitch.....	16.0%
Loss (rosin adhering to walls of still, etc.).....	1.0%

¹ Bulletin No. 229, U. S. Dept. of Agr., Wash., D. C., July 28, 1915.

According to Victor Schweizer,¹ when rosin is distilled with superheated steam, the following yields are obtained:

Acid liquor.....	5.5 - 5.8%
Rosin spirits.....	11.25-12.0%
Blue rosin oil.....	49.0 -50.5%
Brown rosin oil.....	10.25-10.65%
Rosin pitch.....	18.0 -19.0%

The rosin pitch is run from the still while it is hot, and allowed to cool in a suitable receiver. It is fairly uniform in composition and conforms with the following characteristics:

(Test 1) Color in mass.....	Black
(Test 2) Homogeneity.....	Uniform
(Test 4) Fracture.....	Conchoidal
(Test 5) Lustre.....	Dull
(Test 6) Streak.....	Light yellow to brown
(Test 7) Specific gravity at 77° F.....	1.08-1.15
(Test 9c) Consistency at 77° F.....	50-100
(Test 9d) Susceptibility factor.....	Greater than 100
(Test 10c) Ductility at 77° F.....	0
(Test 14a) Behavior on melting.....	Passes rapidly from the solid to the liquid state
(Test 15a) Fusing-point (K. and S. method).....	120-200° F.
(Test 16) Volatile matter, 500° F., 5 hrs.....	10-18%
(Test 17) Flash-point.....	Above 250° F.
(Test 19) Fixed carbon.....	10-20%
(Test 21a) Soluble in carbon disulphide.....	98-100%
(Test 21b) Non-mineral matter insoluble.....	0-2%
(Test 21c) Mineral matter.....	0-1%
(Test 22) Carbenes.....	0-5%
(Test 23) Solubility in 88° naphtha.....	90-100%
(Test 28) Sulphur.....	0.0%
(Test 30) Oxygen in non-mineral matter.....	5-10%
(Test 33) Paraffine.....	0.0%
(Test 35) Sulphonation residue.....	0-5%
(Test 37) Saponifiable constituents.....	25-95%
(Test 41) Diazo reaction.....	Yes
(Test 42) Anthraquinone reaction.....	No
(Test 43) Liebermann-Storch reaction.....	Yes

Rosin pitch is very much like rosin in its physical properties. It is extremely susceptible to temperature changes, and as ordinarily produced, is hard and friable at 77° F. It is characterized by the presence of considerable quantities of unaltered resin acids (10 to 45 per cent), and is free from fatty acids, glycerol, sulphur and paraffine. It withstands weathering very poorly, and has therefore but a limited use. Upon being heated, it passes rapidly from the solid to the liquid state, forming a melt of low viscosity.

¹"The Distillation of Resins," p. 59. New York.

"Burgundy pitch" is the name applied to the oleo-resin which exudes from the Norway spruce (*Abies excelsa*), found in the Vosges Mountains and in the Alps; also from a species of pine obtained in the United States (*Pinus australis*). The crude oleo-resin is melted by boiling with water, and strained to remove any particles of bark or other impurities. It then constitutes the so-called "Burgundy pitch" (*Pix abietina*), sometimes marketed under the name "Vosges pitch." These terms are misnomers, since the material is not a true "pitch," but in reality an oleo-resin. It contains more or less spirits of turpentine, which escaped expulsion during the boiling process, and a quantity of emulsified water imparting to it an *opaque*, yellowish-brown color. In consistency it is a more or less brittle solid, largely susceptible to temperature changes. In summer it softens and gradually flows, and in winter it appears very hard and brittle. It melts easily, decrepitating because of the water present, and has a strong odor because of the the associated spirits of turpentine. On aging it loses its opacity, due to evaporation of the emulsified water, and turns first to a translucent, and then to a transparent brown color, similar to that of rosin. Its composition is substantially the same as rosin, containing in addition, spirits of turpentine and emulsified water.

CHAPTER XV

PEAT AND LIGNITE TARS AND PITCHES

PEAT TAR AND PEAT-TAR PITCH

As previously stated (p. 59), peat is derived from the decomposition of vegetable matter in swampy places, such as marshes and bogs. On the surface we find the growing aquatic plants; somewhat deeper we find their decayed remains; and still deeper a dark colored pasty substance from which the vegetable structure has largely disappeared, containing a substantial percentage of moisture and constituting the crude peat. The plants which result in the formation of these deposits are mainly aquatic, including marine grasses, reeds, rushes, hedges and various mosses. The transformation is caused partly by oxidation in the presence of moisture, and also to some extent by the action of certain forms of bacteria, moulds and fungi. As the mass of peat builds up in thickness, the lower layers are first compacted upon being subjected to pressure, and then gradually carbonized. The essential condition to peat formation is that the vegetable remains shall be deposited at a rate exceeding that of their decomposition. This does not prove to be the case in very warm climates, where the remains are entirely decomposed. The organic matter should only be *partly* decomposed, and since the products of partial decomposition act as a preservative to inhibit further decay, we can readily understand why the building up of peat beds is cumulative. It progresses most rapidly at a mean atmospheric temperature of 45° F., which accounts for the fact that no peat bogs occur between the latitudes of 45° N., and 45° S. It is estimated¹ that there exist in the United States 20 million acres of peat bogs, 30 million acres in Canada, 50 million on the continent of Europe, also approximately 3 million in Ireland.

The following constitute the most important varieties of peat, based on the locality in which they are found:

- (1) "Hill peat" found at mountain tops and derived from plants consisting of Sphagnum and Andromeda mosses, likewise heath.
- (2) "Bottom peat," found near rivers, lakes, etc., in the low-lands, including:
 - (a) dark peat approaching lignite in composition, occurring at the lower parts

¹ Encyclopædia Britannica, 11th Edition.

of the deposit; (b) middle peat, which is lighter in color and in weight than the preceding; (c) the top stratum, which has a fibrous structure.

Peat varies in color from light yellowish, through various tints of brown, to brownish black or black, all of which appear darker when the peat is moist. The lighter shades generally darken to brownish black or black upon exposure to air; due largely to oxidation. In texture, peat varies from light porous matter having a fibrous or woody structure, to substances which are amorphous and clay-like when wet, but appearing quite hard and dense upon drying. Peat may be classified as follows, based upon its physical characteristics:

(1) Turfy peat, consisting of decomposed mosses and aquatic plants, having a yellow to yellowish-brown color, and a soft, spongy, or elastic structure, varying in specific gravity when dry from 0.11 to 0.26.

(2) Fibrous peat, consisting of a distinctly fibrous structure derived from moss, grass, roots, etc., having a brown or black color. It is brittle and easily broken, much less elastic than turfy peat, and when dry has a specific gravity of 0.24 to 0.67.

(3) Earthy peat, forming earth-like masses when dry, and sometimes showing a vestige of fibrous structure. Fractures with more or less difficulty, presenting a surface with little lustre. Specific gravity 0.41 to 0.90.

(4) Pitchy peat. Dense and hard when dry, resisting fracture and breaking with a smooth and often lustrous surface approaching that of lignite, Specific gravity 0.62 to 1.03.

The chemical composition of peat is but little understood. It is regarded as a mixture of water, inorganic matter (calcium and iron compounds), vegetable fibres and humus acids (such as humic, ulmic, crenic, apocrenic, etc.). According to H. Bornträger¹ the black varieties contain between 25 and 60 per cent of humus acids, 30 to 60 per cent of fibre, and 3 to 5 per cent of ash. Nitrogenous compounds are also present varying from 1 to 3 per cent of the dry weight, resulting partly from the associated animal matter, and also due partly to the humus acids combining with atmospheric nitrogen, forming what are known as azo-humic acids. Sulphur is also present in amounts between 0.1 and 5.3 per cent based on the dry weight.

Resinous substances are found in certain varieties of peat to which various names have been assigned, also bodies of a waxy nature derived from the associated gelatinous algæ, known as "sapropel."

When recently formed, the peat beds are but loosely compacted, but as they accumulate, the under layers become compressed, so what once was a foot thick may be concentrated to several inches. In other

¹ *Zeit. anal. Chem.*, **39**, 694, 1900; **40**, 639, 1901.

cases the beds become covered with sedimentary rocks, which augment the pressure, and gradually transform the peat into lignite.¹

Peat is generally collected by cutting trenches through the bog with a spade, and removing it in sods about 3 to 4 ft. long. The deposits are worked in steps or tiers. Mechanical excavators and dredges have also been used for the purpose. The sods are allowed to drain, then air-dried and finally heated to a high temperature in either stationary or revolving ovens, to remove the water. Peat as freshly mined contains 75 and 90 per cent by weight of water, which must of necessity be removed before the product can be used as a fuel. Air-dried peat carries 10 to 15 per cent of moisture, and the artificially dried peat between a trace and 80 per cent of mineral ash, consisting principally of sand and clay with smaller quantities of iron oxide, calcium and magnesium salts. The maximum quantity of ash usually considered allowable when used as a fuel is 25 per cent of the dry weight. Peat with less than 5 per cent ash is considered good, between 5 and 10 per cent as fair, and over 10 per cent as poor. With peat containing less than 10 per cent of ash in the moisture-free state, the fixed carbon varies between 15 and 35 per cent, averaging about 30 per cent.

It is customary to briquette the partly dried peat, carrying 10 to 15 per cent of water, and then continuing the drying until practically all the moisture is removed, and the residual peat compacted into tough briquettes suitable for use as fuel. It is briquetted under a pressure of 18,000 to 30,000 lb. per square inch, which generates sufficient heat to liberate some of the tarry compounds of the peat, causing the sides of the briquettes to assume a highly polished glaze. The product is claimed to have a calorific value almost equal to that of coal.

In 1904 Dr. M. E. Kenberg, of London, devised a process for dehydrating peat, known as "wet carbonizing," which seems to offer possibilities. The wet peat, containing 85 to 90 per cent of water, is subjected to a temperature slightly above 300° F., in a special form of apparatus, and under a pressure of 150 lb. This causes the peaty substances to coagulate and perhaps undergo a slight carbonization, so that their physical properties become altered. The peat is darkened in color and transformed from a colloidal to a fine-grained form, which can readily be separated by filtering, so that the moisture in the filtered residue amounts to only 5 per cent. The process is continuous and the cost of operation low.

The briquetted peat is ordinarily used directly as fuel, and to a limited extent for the recovery of gas, tar, ammonium compounds and coke. Various methods

¹"Reports upon the Irish Peat Industries," Hugh Ryan, *Econ. Proc. Roy. Soc. Dublin*, Part II, Vol. 1, pt. 13; E. Riés, 55th Ann. Rept. N. Y. State Mus., p. 55, 1903; "Die Moore der Schweiz," Berne, Switzerland, 1904, issued by the Smith Geological Commission, Chapter III contains a bibliography on peat; R. Chalmers on Canadian Peat, *Min. Res. Canada*, 1904; McCourt and Parmelee, *Ann. Rept. State Geol., N. J.*, 1905; A. L. Parsons, 57th Ann. Rept. N. Y. State Mus., Vol. 1, p. 16, 1905; "Peat and Its Products," by V. C. Kerr, 1905; J. A. Holmes, *Bull. No. 290*, U. S. Geol. Survey, Wash., D. C., 11-15, 1906; "Peat, Its Use and Manufacture," by P. R. Björling and F. T. Gissing, London, 1907; "The Data of Geochemistry," Clark, *Bull. No. 330*, U. S. Geol. Survey, Wash., D. C., 1908; "Peat and Lignite, Their Manufacture and Uses in Europe," E. Nystrom, Dept. of Mines, Ottawa, Canada, *Bull. 19*, 1908; "Commercial Peat," by F. T. Gissing, 1909; "Investigation of the Peat Bogs and Peat Fuel Industry in Canada," Report 30 by Nystrom and Anrep, Ottawa, Canada, 1908; Report 71 by Anrep, Larson; Ekelund, etc., Ottawa, Canada, 1909-10; Report 266 by Anrep, 1911-12; Report 351 by Anrep, Ottawa, Canada, 1913-14; "The Uses of Peat," by Chas. Davis, *Bull. No. 16*, Bureau of Mines, U. S. Dept. of Interior, Wash., D. C., 1911.

have been used for distilling peat, similar to those employed for treating coal. Peat may be destructively distilled in closed retorts, obtaining a gas suitable for use as a fuel, likewise tar, ammonia, and a good grade of coke, but in the United States this process has only been carried on in a small experimental way. At the present time the cost of drying and briquetting peat brings its price higher than that of bituminous coal. For these reasons neither peat tar nor peat-tar pitch are produced in commercial quantities. It is probable, however, that in the future, greater attention will be paid to the enormous peat deposits now inoperative. A brief description of the European practice, therefore, will not be out of place.

The Zeigler process of treating peat has attracted attention in Germany, Bavaria, and Russia. It is distilled in retorts 40 ft. high, having an elliptical cross-section. The upper portion is constructed of cast iron and the lower of fire brick. Vertical fire-brick flues are built outside the central chamber. A feed-box is attached to the top of the retort with a gas-tight cover opening inward, and the lower portion of the retort terminates in a hopper with two openings from which the coke is removed from time to time. The volatile matter is drawn off by suction, passed through condensers to remove the aqueous liquor and tar, and the purified gases caused to burn in the fire-brick flues surrounding the retort. The products of combustion, having a temperature of 1800° F., are used for drying the peat until it contains about 15 to 20 per cent of moisture. The tar is separated from the aqueous liquor by heating the mixture with steam to the melting-point of the tar, which then rises to the surface. It is a black, viscid liquid with a disagreeable acrid odor, representing 2 to 5 per cent of the dry weight of the peat used. The aqueous liquor contains ammonium salts, acetic and other organic acids, wood alcohol, and pyridine bases. The tar is slowly distilled, and after the water ceases to pass over, the receiver is changed and the distillation continued until 45 per cent of oily distillate has been collected. The receiver is again changed, and heavy oils containing paraffine wax, totalling about 30 per cent by weight of the tar caught separately, leaving 15 to 20 per cent of peat-tar pitch in the retort, which is finally drawn off. The oily distillate first recovered is redistilled into light naphtha (density under 0.83), and heavy naphtha (density 0.85). The heavy oil is cooled and pressed to separate lubricating oil from the paraffine wax. The products are treated first with concentrated sulphuric acid and then with caustic soda to remove tarry impurities and creosote oil respectively, the latter being recovered in the form of creosote or carboic acid.

The following represent the percentages by weight of by-products obtained per ton of the air-dried peat:

Gases and loss.....	15%
Aqueous liquor.....	40%
Peat tar.....	9%
Coke.....	36%
Total.....	100%

The following percentages by weight of by-products were obtained from the aqueous liquor:

Ammonium sulphate.....	4.0%
Methyl alcohol.....	2.0%
Pyridine bases.....	0.2%
Acetic acid.....	1.5%

The dry peat tar yields the following:

	Crude, Per Cent.	After Purification Per Cent.
Light naphtha.	16	12
Heavy naphtha.	30	25
Lubricating oil.	15	13
Paraffine wax.	12	2
Peat-tar pitch.	16	16
Creosote.	11	12
Loss.	11	20
	100	100

Holde reports ¹ that the destructive distillation crude undried peat produces:

Non-condensable gases.	12-21%
Aqueous distillate.	36-40%
Peat tar.	2-10%

Briquetted Yorkshire peat on distillation yields between 11 and 22 lb. of ammonium sulphate per ton, and approximately 38 gal. of tar and water. The gases evolved are sufficient to conduct the process of distillation which yields a coke, hard enough to be used in blast furnaces. The tar on distillation yields the following fractions:

Below 150° C.	1.35% distillate (sp.gr. 0.867)
150-250° C.	29.90% distillate (sp.gr. 0.953)
Above 250° C.	50.00% distillate (sp.gr. 0.941)
Also a residue amounting to 18.75% of hard peat-tar pitch.	
The distillate boiling above 250° C. contained 6 per cent of paraffine wax.	

Graefe (loc. cit.) reports the following tests on Russian peat tar:

Sp.gr.	0.936
Boiling-point.	195° C.
Distillate of crude oils.	20%
Peat-tar pitch.	74.1%
Creosote in the crude oils.	35%
Paraffine in the crude tar.	9.96%
Fusing-point, of the crude tar.	59.2° C.

E. Börnstein and F. Bernstein ² devised a process for subjecting crude peat to destructive distillation, and recover the nitrogenous compounds. The resulting tar after dehydration contained phenols, 18 per cent; nitrogenous bases (alkaloids), 1 per cent; neutral oils, 34 per cent; and pitch (containing paraffine), 47 per cent.

In Europe and Canada attempts have been made to utilize peat for manufacturing producer gas (see p. 172). A special type of producer, known as the Körting "Double Zone, Up-draft Peat Gas Producer," has been designed for the

¹ Loc cit., p. 363.

² *J. Gas Lighting*, **129**, 731, 1915; also *Z. angew. Chem.*, **27**, Aufsatz, 71-2, 1914.

purpose, as illustrated in Fig. 80. It operates on peat which has been air-dried for four weeks, containing 25 to 50

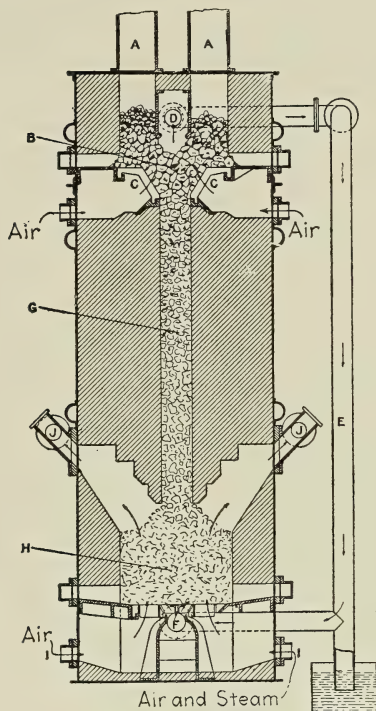

Fig. 80.—Körting Double Zone Up-Draft Gas Producer for Peat.

operates on peat which has been air-dried for four weeks, containing 25 to 50 per cent moisture, thus saving the time and expense of drying artificially. This moisture is converted into steam in the producer, and obviates the necessity of introducing steam with the air, as in the case of coal or coke (p. 239). The air-dried peat *B* in the form of sods measuring $8 \times 4 \times 2$ in., weighing $1\frac{3}{4}$ to 2 lb. each, is charged into the hoppers *A-A*, from which it falls upon the sloping grates *C-C*, where it undergoes partial combustion. Sufficient air is admitted below the grates to distil off the moisture and volatile matter. The carbonized fuel then passes downward through the comparatively narrow duct *G* to a second combustion zone *H* at bottom of the producer, where the combustion is carried to completion. The moisture and tarry vapors evolved in the upper zone pass through the opening *D* and downcomer *E* and introduced at *F* directly below the grate-bars of the lower zone, whence they pass upward through the incandescent fuel to the draw-off pipes *J-J*. The air admitted to the lower zone through the pipes *I-I* is carefully regulated, so that a proper interaction will take place between the fuel, moisture, and tarry vapors, resulting in the ultimate formation of hydrogen and carbon-monoxide. The tarry matters are partly converted into permanent gases, and partly burned. A good portion of the tar, however, escapes decomposition and is carried by the producer gas, from which it must be separated by a tar extractor and scrubber. The tar recovered in this manner amounts to 1 to 2 per cent by weight of the dry peat and is very similar in composition and properties to peat tar derived from destructive distillation processes.¹

Dehydrated peat tars in general, test as follows:

(Test 1) Color in mass.....	Black
(Test 7) Specific gravity at 77° F.....	0.90-1.05
(Test 9) Hardness or consistency.....	Liquid
(Test 15a) Fusing-point (K. and S. method).....	40-60° F.
(Test 16) Volatile matter at 500° F., in 4 hrs.....	50-85%
(Test 17a) Flash-point.....	60-95° F.
(Test 19) Fixed carbon.....	5-15%
(Test 21a) Soluble in carbon disulphide.....	98-100%
(Test 21b) Non-mineral matter insoluble.....	0-2%
(Test 21c) Mineral matter.....	0-1%
(Test 22) Carbenes.....	0-2%

¹ "Use of Peat in Gas Producing Plants," E. C. C. Baly, *J. Soc. Chem. Ind.*, **35**, 1240, 1916.

(Test 23)	Solubility in 88° naphtha.....	95-100%
(Test 28)	Sulphur.....	Less 1%
(Test 30)	Oxygen in non-mineral matter.....	5-15%
(Test 33)	Paraffine wax.....	5-15%
(Test 35)	Sulphonation residue.....	5-15%
(Test 37)	Saponifiable constituents.....	5-15%
(Test 41)	Diazo reaction.....	Yes
(Test 42)	Anthraquinone reaction.....	No
(Test 43)	Liebermann-Storch reaction.....	No

Peat-tar pitch is obtained by the evaporation or steam distillation of peat tar. It is not an article of commerce in the United States. Its hardness or consistency, as well as its fusing-point, depend upon the extent to which the distillation has been conducted. Ordinarily peat-tar pitch tests much the same as lignite-tar pitch, the results being included on table XXXV, p. 482. It is highly susceptible to temperature changes, and withstands exposure to the weather very poorly.

LIGNITE TAR AND LIGNITE-TAR PITCH

The U. S. Geological Survey estimates that 1,087,514,400,000 tons of lignite are available in the United States, but it is used only in a limited way, due to the abundance of other types of fuel.¹ Large deposits occur also in Alberta, Saskatchewan and Manitoba, Canada. A zone covering about 1700 square miles has been located in Australia, and one small deposit has been reported in England (at Bovey-Tracey in Devonshire). A commercial product known as "kaumazite" is made from Bohemian lignite by a process of low-temperature distillation.² In Germany, however, the lignite industry has made much more rapid advances owing partly to the scarcity of high-grade coals, and partly to the fact that the deposits are located close to large cities, making the cost of transportation low. The lignite is accordingly used as a fuel for steam plants, for manufacturing producer gas, and for distillation purposes to recover its valuable by-products.

The descriptions of the methods which follow are based on German practice as carried out in the following localities, viz.:

- (1) near Horrem, a short distance west of Cologne in Rhine Province;
- (2) in the neighborhood of Halle on the Saale, in the Provinces of Saxony and Thuringia; and
- (3) at Messel, near Darmstadt in Hessen Province.

The so-called browncoal (a variety of lignite) is mined at the first two localities. It is estimated that 20,000 to 25,000 tons were briquetted daily in the Cologne mining district alone, where the beds run from 30

¹ Charles A. Davis, Tech. Paper No. 55, Bureau of Mines, Dept. of Interior, Wash., D. C., 1913.

² Daniel Bellet, *Rev. gén. Sci.*, 28, 118, 1917.

to 350 feet thick, averaging 75 feet. Browncoal differs somewhat from American lignite in carrying a higher percentage of moisture (about 60 per cent instead of 25 to 50 per cent). As mined, browncoal is soft and either unconsolidated or but slightly consolidated, so that it can be cut easily with a knife. The Messel deposit carries about 30 per cent clay and 45 per cent water, the organic constituents apparently being combined chemically with the clay. It is greasy in consistency, having a black color with a greenish cast. The bed covers about 240 acres in a hemispherical depression, and measures 480 ft. in thickness under a cover 13 ft. thick composed of gravel and clay.

Browncoal in the Cologne and Halle regions is found in stratified beds in which the layers alternately appear lighter and darker in color. The lighter layers form a brownish-black plastic and greasy mass when freshly mined, and a yellowish to light brown pulverulent substance when dry. They are characterized by the presence of waxy constituents soluble in carbon disulphide, benzol, etc. The darker layers form a black plastic mass when fresh, and a dark brown to black earthy substance after drying. They differ from the light-colored layers, in being substantially free from soluble waxy constituents. The two varieties are sorted during the process of mining. The light-colored product resembles the mineral pyropissite (see p. 160) but yields smaller percentages soluble in benzol, etc., the highest grade averaging 32.5 per cent (based on the dry weight).

The lighter variety of lignite has been incorrectly termed "bituminous lignite," and the darker, "non-bituminous lignite." For purposes of differentiation, we will refer to them as "retort lignite" and "fuel lignite" respectively.¹ Retort lignite ranges in specific gravity from 0.9 to 1.1 and melts at ignition, whereas fuel lignite has a gravity of 1.2 to 1.4, and does not melt.

It is assumed that these two varieties of lignite, since they occur in the same deposit, result from differing conditions surrounding their formation, as for example a variation in water level. Thus if the original vegetable matter containing a large amount of waxy constituents was protected from the action of atmospheric oxygen by being surrounded with water until the transformation into lignite had been completed, then the woody tissue was more or less preserved, and fuel lignite resulted. If, however, the water receded and exposed the deposit to the action of air, then the woody tissue became partly or wholly oxidized, leaving the more resistant materials behind, and resulting in the formation of retort lignite. If the process of atmospheric oxidation had been carried to the greatest possible extent, then the waxes only remain behind, in

¹ In Germany they are termed "Distillation Coal" (Schwelkohle) and "Fire Coal" (Feuerkohle).

the form of the mineral pyropissite. As stated previously, pyropissite is no longer mined, since its total available supply has been exhausted. Lignite as freshly mined is more or less rapidly acted upon by atmospheric oxygen, the dark variety being more susceptible than the light one. A typical lignite vein carries about twice as much fuel lignite as retort lignite.

Retort lignite is treated in one or two ways, viz.:

(1) It is subjected directly to low temperature destructive distillation, or

(2) It is first extracted with a solvent to remove the montan wax and the residue either distilled destructively or briquetted and sold as fuel.

Fuel lignite is also treated in one of two ways, viz.:

(1) If it is comparatively free from ash, it is briquetted and used as fuel;

(2) If it contains a large proportion of ash, as with Messel lignite, it is used for manufacturing producer gas by combustion in an atmosphere of air and steam, so that practically all the carbonaceous matter is consumed, leaving almost pure ash behind. Since Messel lignite in its crude state contains but 25 per cent of combustible material, it is unsuitable for use as fuel, or for purposes of destructive distillation.

When the lignite is to be used for fuel, it is converted into briquettes by subjecting the granulated material to great pressure. The heat generated during this operation softens the waxy substances present, and binds the particles into a solid mass. It is unnecessary, therefore, to add any extraneous binding medium.

Retort lignite is unsuitable for fuel or manufacturing briquettes, as the large quantity of waxy constituents present will soften when heated, causing the briquettes to melt and drop through the grate bars. When the retort lignite has been extracted with solvents to remove the "montan wax," the residue still contains enough waxy constituents to enable it to be briquetted.

Lignite is mined by the open-cut method where the over-burden is not very thick, or by driving shafts and tunnels when the bed is situated some distance below the surface. In the case of open-cut mining, the over-burden is first removed with steam shovels, and the lignite excavated by mechanically operated chain and buckets, which load the material into small skips.

Shaft mining presents a number of difficulties owing to the softness and instability of the crude lignite. The shafts must be well timbered, and in many cases it is first necessary to freeze the lignite before it can be handled. This is accomplished by driving a series of vertical pipes at the bottom of the shaft through which salt solution cooled to a low temperature is caused to circulate. This solidifies the lignite, and enables it to be excavated without danger of cave-ins.

Where the lignite is used for manufacturing briquettes, it is first crushed to about the size of peas, then passed through sieves, and finally through a drier to reduce the moisture to approximately 15 per cent. A tubular drier, heated with steam, has been found most satisfactory for the purpose.¹ The lignite powder

¹"Briquetting Tests of Lignite at Pittsburgh, Pa.," Bulletin No. 14, Bureau of Mines, U. S. Dept. of Interior, Wash., D. C., 1911.

is fed into a briquetting press, where it is subjected to a pressure between 18,000 and 22,500 lb. per square inch.¹

When the retort lignite is to be subjected to destructive distillation, it is used directly as it comes from the mine, without drying. In fact, the presence of the water materially assists the distillation process by preventing the volatile products from decomposing too extensively. The water is converted into steam which quickly removes the vapors from the hot retort and prevents cracking. Practice has shown that

the moisture content should not be less than 30 per cent. In distilling lignite, the humic acids present are converted into the so-called "neutral bodies," the cellulose derivatives into phenolic bodies and unsaturated hydrocarbons, and the waxy constituents into saturated hydrocarbons and paraffine wax.

It is claimed that the Rolle retort shown diagrammatically in Fig. 81 has been found most satisfactory for treating lignite. It is 5 to 6 ft. in diameter by 20 to 25 ft. high, and works continuously, the operation progressing in two stages, viz.:

- (1) Drying the lignite.
- (2) Deccomposing the lignite into gas, water, tar and coke.

The contrivance is composed essentially of two concentric cylinders, an outer one of fire brick and an inner one consisting of a stack of

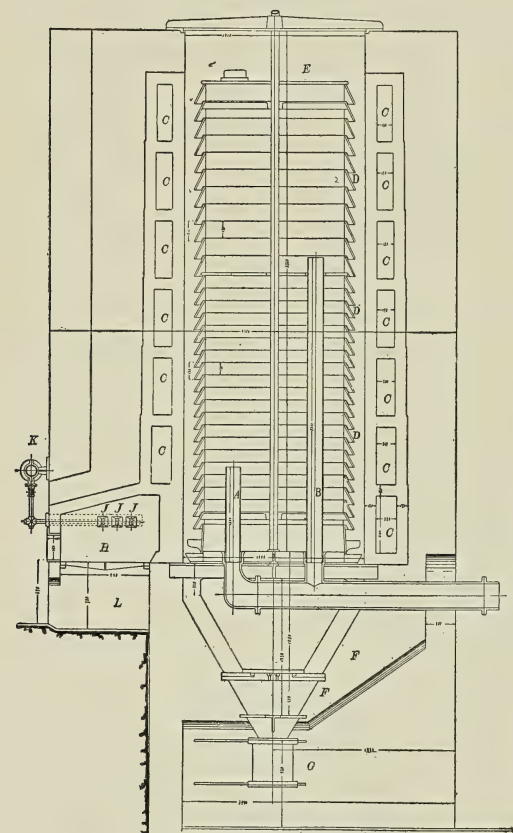

FIG. 81.—Retort for Distilling Pure Lignite.

conical rings assembled in louvre fashion, constructed of iron or fire clay. The lignite after being crushed into lumps about $1\frac{1}{2}$ to $2\frac{1}{2}$ in. in diameter is

¹"The Production and Use of Browncoal in the Vicinity of Cologne, Germany," by C. A. Davis, Tech. Paper No. 55, Bureau of Mines, U. S. Dept. of Interior, Wash., D. C., 1913.

introduced into the space between the concentric cylinders. The products of distillation pass out through the flues *A* and *B*. The openings *C* represent the fire-flues; *D*, the stack of conical rings; *E*, the cap covering the rings; *F*, an inverted cone of metal into which the coke falls after the lignite has been thoroughly carbonized; *G*, a device for intermittently drawing off the coke; *H*, the combustion chamber; *J*, vents for introducing the gases; *K*, the pipes through which the gases enter; and *L*, the fire place which comes into play when the retort is first started up. Coal or lignite is burnt on the grate, until the process of destructive distillation commences, whereupon the resulting non-condensable gases are introduced through *K* and *J*, and caused to burn in the flues *C*. The space over the cap *E* is kept filled with lignite, and the rate of travel through the retort is controlled by the frequency with which the coke is removed from the chamber *G*.

The temperature at which the distillation takes place varies between 500 and 900° F., and the vapors issue from the retort at 250 to 300° F. The products of decomposition are drawn from the retort by a slight suction, and passed through a series of air condensers, which removes most of the tar, the high boiling-point oils, and part of the water. The condensation is completed by passing the gases through pipes surrounded by water.¹

The tar is separated from the condensed water by warming it and allowing it to stand quietly in a suitable receptacle. The tar being lighter than the water, rises to the surface, and is drawn off when the separation is complete.

In recent years the following percentages have been recovered:

Water.....	50-60%
Tar.....	5-10%
Coke.....	25-35%
Gas.....	Balance

The coke has a more or less granular structure, and after quenching with water, carries about 20 per cent of moisture and 15 to 25 per cent of ash, depending upon the character of the raw lignite.

The following figures show the yield on distilling an exceptionally rich lignite containing 32.5 per cent of constituents soluble in carbon disulphide, which incidentally, is very much higher than the present run of the mines:

	Original Lignite, Per Cent.	Lignite after Extrac- tion with Solvents. Per Cent.	Montan Wax Extracted, Per Cent.
Gases and loss.....	9	12	5
Aqueous liquor.....	23	19	5
Tar.....	33	21	78
Coke.....	35	48	12
Total.....	100	100	100

¹ "Die Braunkohlenteer-Industrie," by Ed. Graefe. Halle a. S. 1906.

In Southern Saskatchewan, Canada, the raw lignite tests as an average: water, 26.13 per cent; volatile hydrocarbons, 28.11 per cent; fixed carbon, 38.16 per cent; ash, 6.86 per cent; and sulphur, 0.74 per cent. It is treated in a vertical chamber oven, like a horizontal by-products oven, charged and discharged continuously. The gradual application of heat increases the yield of hydrocarbon by-products at a high speed of treatment. Rapid evolution of gas results at 700–900° F., and ceases at 1000° F. A ton of the crude lignite yields: gas, 10,000 cu. ft.; crude tar (water-free), 15 gal.; ammoniacal liquor, 65 gal.; and coke, 955 lb. On distillation, the tar yields: light oils, 11.5 per cent; creosote oils, 13.5 per cent; paraffine, 34.1 per cent; and hard pitch, 24.5 per cent. About 15 lb. of ammonium sulphate are recovered per ton.¹

The Messel lignite carrying a large percentage of mineral water is treated in a special form of retort built in batteries, as illustrated in Fig.

82. The process takes place in three stages, viz.:

(1) Drying of the lignite and accompanying generation of steam, taking place in the zones *c*.

(2) Distillation of the dried material, taking place in zones *b*.

(3) Combustion of the residual coke by means of air and the steam generated in (1), taking place in zones *a*. The steam liberated in zones *c* is passed through the flues *G-e*, *f-f*, and *G-g* respectively into the zones *a*, as illustrated.

In other words, the steam generated by the lignite itself, is used to decompose the coke into producer gas, as described on p. 172. The gas is caused to burn in the chambers *A*, *B* and *C* respectively, the products of combustion passing through the openings *o, o*. Pipe *d* represents the outlet for the products of decomposition, and *s* represents the supply pipe for the heated gas. The paths of the products are indicated by the arrows. The yield of tar varies between 4 and 14 per cent, averaging about 7½

per cent (19 gallons per ton), that of gas 6 per cent, water 44 per cent and coke 36 per cent. The residue discharged from the bottom

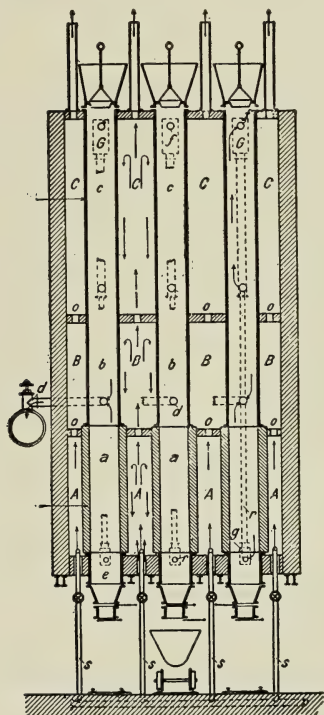

FIG. 82.—Retort for Distilling Impure Lignite.

¹ "Methods of Utilizing Lignite," S. M. Darling, *J. Gas Lighting*, 131, 456, 1915.

of the retort is composed of mineral matter carrying 8 per cent of undecomposed carbon. More gas is generated during the process than is required for heating the retort, and the excess is used for other purposes.

Lignite in either the air-dried or briquetted form is gradually being used more and more, especially in Europe, for manufacturing producer gas. Either a Westinghouse double-zone gas producer (see p. 242) or a Körting double-zone up-draft producer may be used. The latter is similar in construction to the Körting peat-gas producer (Fig. 80), but the channel is greater in cross-section, and steam must be introduced with the air below the grate-bars in the lower zone when artificially dried briquetted lignite is used. About 60 cu. ft. of gas are produced from each pound of the dry lignite, also $\frac{1}{4}$ to $\frac{1}{2}$ per cent by weight of lignite tar, which is separated from the producer gas in the usual manner. When the air-dried lignite is used, the process is very similar to that which takes place in the Messel retorts, but the yield of tar is much smaller since the moisture and tarry vapors generated in the upper part of the producer are passed through the incandescent lignite from below, to decompose the tar as much as possible, and correspondingly increase the yield of producer gas. In other words, the Messel retort is designed primarily to recover the tar, and the lignite-producer to generate gas.

Lignite tar has a buttery consistency at ordinary temperatures with a dark brown to black color. It is composed of liquid and solid members of the paraffine and olefine series, together with a small quantity of the benzol series, also the higher phenols and their derivatives. It is characterized by the presence of a substantial proportion of solid paraffine (10 to 25 per cent) and from 0.5 to 1.5 per cent of sulphur.

In general, dehydrated lignite tar conforms with the following characteristics:

(Test 1) Color in mass	Yellowish brown to greenish brown to brownish black
(Test 7) Specific gravity at 77° F.	0.85-1.05
(Test 9) Hardness or consistency at 77° F.	Salve-like to buttery
(Test 10) Ductility at 77° F.	None
(Test 13) Odor on heating	Characteristic
(Test 15a) Fusing-point (K. and S. method)	60-90° F.
(Test 16) Volatile matter at 500° F., 4 hrs.	70-85%
(Test 17a) Flash-point (Pensky-Martens tester)	75-90° F.
(Test 19) Fixed carbon	5-20%
(Test 20) Distillation test	The boiling point ranges between 80 and 400° C., the greater portion distilling between 250 and 350° C.
(Test 21a) Soluble in carbon disulphide	98-100%
(Test 21b) Non-mineral matter insoluble	0-1%
(Test 21c) Mineral matter	0-1%
(Test 22) Carbenes	0-2%

(Test 23) Solubility in 88° naphtha.....	95-100%
(Test 28) Sulphur.....	0.5-1.5%
(Test 29) Nitrogen.....	Less than 0.1%
(Test 30) Oxygen.....	5-10%
(Test 31) Free carbon.....	0-1%
(Test 32) Naphthalene.....	½-1%
(Test 33) Paraffine.....	10-25%
(Test 35) Sulphonation residue.....	10-20%
(Test 37) Saponifiable constituents.....	5-20%
(Test 41) Diazo reaction.....	Yes
(Test 42) Anthraquinone reaction.....	No
(Test 43) Liebermann-Storch reaction.....	No

Graefe reports ¹ that destructively distilled lignite tar will range as follows:

	Good Tar.	Average Tar.	Poor Tar.
Specific gravity at 77° F.....	0.867	0.886	0.917
Commences to boil.....	190° C.	130° C.	174° C.
Crude oil distillate.....	30%	37½%	24.1%
Paraffinaceous residue.....	63%	55.5%	68.9%
Paraffinaceous residue solidifies at.....	29.8° C.	25.8° C.	26.1° C.
Creosote in crude oil distillate.....	11.0%	15.0%	19.5%
Creosote in paraffinaceous residue.....	9.0%	6.0%	7.0%
Paraffine in paraffinaceous residue.....	23.3%	18.5-22.0%	18.2%
Paraffine in the tar itself.....	14.67%	10.2-12.5%	12.53%
Fusing-point of the paraffine.....	51.0° C.	46.7° C.	52.7° C.

The aqueous liquor separated from the lignite tar contains 0.03 to 0.07 per cent of ammonium salts, which are so small in amount that it scarcely pays to recover them. Lignite contains an average of 0.3 per cent of nitrogen, which is distributed among its products of distillation as follows: viz. The gas contains 12 per cent, the aqueous liquor 12 per cent, the tar 10 per cent, and the residual coke 66 per cent.

In practice, lignite tar is distilled to separate various oils and paraffine wax. The distillates are purified by treatment with acids and alkali, and the paraffine by re-crystallization.

The distillation is conducted in one of three ways, viz.:

- (1) At atmospheric pressure, without steam.
- (2) By means of steam.
- (3) Under vacuum, sometimes supplemented with steam.

Vacuum distillation is generally used, as it saves fuel, reduces the time and prevents cracking of the distillates. The best practice consists in using a slight vacuum at the beginning of the distillation, and gradually increasing it until the paraffine begins to distil, when it is maintained at 16 to 28 in. of mercury by a steam injector, or vacuum pump.

With steam distillation, either plain or superheated steam may be used, and direct heating of the retort may be dispensed with in the latter case.

The distillation may be intermittent or continuous. European practice provides for the continuous distillation of the dehydrated tar in a

¹ "Laboratoriumsbuch für die Braunkohlenteer-Industrie," Halle a. S., p. 38, 1908.

vertical cylindrical still with a hemispherical bottom having a dome-shaped cover carrying the exit pipe and fastened to the body of the still. Each still is connected with a condenser composed of a circular coil of metal piping immersed in a water tank. Between 10 and 20 stills are erected side by side on a common brick setting.

Gases derived from the destructive distillation of the lignite, are mixed with air and allowed to burn in flues underneath and around the stills.

Lignite tar is first distilled to $\frac{1}{4}$ its original bulk, and the combined residues of several stills are run into a separate retort. In some cases the residues are distilled to produce lignite-tar pitch, but in the majority they are distilled until nothing but coke remains. By thus treating the residues in separate retorts, the lives of the first retorts are lengthened materially, and the wear and tear concentrated on a few. The retorts in which the preliminary distillation takes place are of course subjected to a much lower temperature than those in which the residues are treated.

When lignite tar is distilled to coke, a certain amount of cracking occurs, and consequent formation of tarry matter in the distillates, which is removed by treating with sulphuric acid, and the resulting sludge worked up into lignite-tar pitch as will be described later.

Obviously the pitches derived in these two ways differ in their physical properties, and particularly in the quantity of associated paraffine, which is smaller in lignite-tar-sludge pitch.

The tar is fractioned into crude oil (about 33 per cent), a paraffinaceous distillate (about 60 per cent), red oil (about 3 per cent), permanent gases (about 2 per cent) and coke (about 2 per cent).

The crude oil is re-distilled into naphtha, illuminating oil, cleaning oil, gas oil and light paraffine oil (vaseline oil). The paraffinaceous mass is cooled and pressed, which removes the heavy paraffine oil from the paraffine wax. The paraffine wax is then re-crystallized and separated into the soft paraffine wax and hard paraffine wax respectively.

According to Scheithauer (*loc. cit.*), an average grade of lignite tar will yield the following products, viz.: benzine 5 per cent, lubricating oil 5 to 10 per cent, light paraffine oils 10 per cent, heavy paraffine oils 30 to 50 per cent, hard paraffine 10 to 15 per cent, soft paraffine 3 to 6 per cent, dark-colored products 3 to 5 per cent, coke, gas and water 20 to 30 per cent.

If the distillation of lignite tar is not continued to coke, lignite-tar pitch is obtained, amounting to about 5 per cent by weight of the tar.

The following diagram shows the essential steps in treating lignite tar by fractional distillation, including the two alternatives of running to pitch and coke respectively.

TABLE XVIII

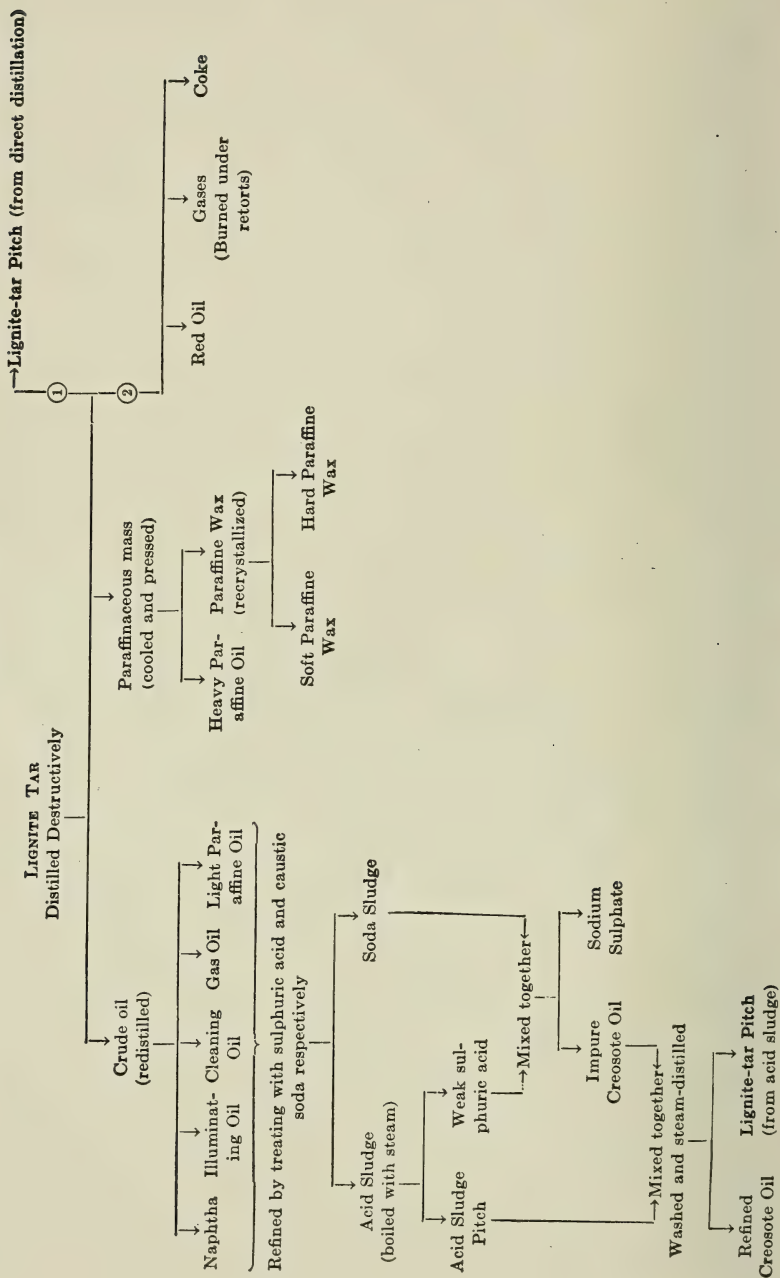

The fractions are purified by treating successively with sulphuric acid and caustic soda, which improves the color and odor, and enables the products to command a higher price. The steps in refining include:

- (1) Treatment with 50° Baumé sulphuric acid.
- (2) Treatment with 66° Baumé sulphuric acid.
- (3) Washing with hot water.
- (4) Treatment with a small volume of 38° Baumé caustic soda.
- (5) Treatment with a large volume of 38° Baumé caustic soda.
- (6) Washing with hot water.

The preliminary treatment with weak sulphuric acid removes a portion of the basic constituents, including the pyridine. The stronger sulphuric acid extracts the remaining basic substances, the tarry matters which impart a dark color, a portion of the unsaturated hydrocarbons and the resinous constituents. The small quantity of alkali serves to neutralize the acid, and the larger quantity to remove the creosote oils which would impart a disagreeable odor and darken on exposure to light.

The chemical treatment is carried out in lead-lined steel vessels, and the mixing effected with a current of air.

The following represent roughly the quantities of acid and alkali required to purify the various fractions:

	50° Bé. Sulphuric Acid, Per Cent.	66° Bé. Sulphuric Acid, Per Cent.	38° Bé. Caustic Soda, Per Cent.
Naphtha.....	$\frac{1}{2}$	7	$\frac{1}{2}$
Illuminating Oil.....	$\frac{1}{2}$	5	$\frac{1}{2}$
Cleaning Oil.....	$\frac{1}{2}$	3	$\frac{1}{2}$
Soft paraffine wax.....	$\frac{1}{2}$	5	2 $\frac{1}{2}$
Hard paraffine wax.....	$\frac{1}{2}$	6	2

The total quantity of sulphuric acid required to refine the various fractions varies between 6 and 7 per cent by weight of the tar, and that of caustic soda between 1 and 1 $\frac{1}{2}$ per cent.

The following refined products are obtained:

Naphtha. Specific gravity, 0.800–0.820; flash-point, 25–35° C.; boiling commences at 136° C., 7 per cent distils under 150°, 12 per cent distils under 200°, and the balance under 250° C.

Illuminating Oil. Specific gravity, 0.820–0.835; flash-point, 35–50° C.; boiling commences at 136° C., 4 per cent distils under 150°, 84 per cent distils under 200°, and the balance under 250° C.

Cleaning Oil. Specific gravity, 0.835–0.860; flash-point, 60–70° C.; boiling commences at 189° C., 4 per cent distils under 200°, 95 per cent distils under 250°, and the balance under 300° C. It is free from paraffine wax.

Gas Oil. Specific gravity, 0.875–0.900; flash-point, 80–90° C.; ignition-point, 100–120° C.; boiling commences at about 200° C., 20–30 per cent distils under 250° C., and 70–80 per cent under 300° C.

Light Paraffine Oil. Specific gravity, 0.900–0.915; flash-point, 90–100° C.; ignition-point, 130° C.; boiling commences at 210–220° C., 2 per cent distils under 250° C., and 33 per cent distils under 300° C.

Heavy Paraffine Oil. Specific gravity, 0.915–0.930; flash-point, 100–110° C.; ignition-point, 130–165° C.; boiling commences at 230° C., 2 per cent distills under 250° C., and 16 per cent distills under 300° C.

Paraffine Wax. Fusing-point varies from 35 to 62° C. (K. and S. method). Soft paraffine wax is understood to fuse below, and hard paraffine wax above 50° C. The crude wax flashes between 160 and 165° C. Its specific gravity varies with the fusing-point, ranging between 0.880 and 0.915.

The tar produced from Messel lignite is treated in a similar manner, but only the first fraction of the distillate is refined with chemicals, using approximately 2 per cent of sulphuric acid and 3 per cent of caustic soda.

After the chemical treatment, the acid and soda sludges are settled off. The acid sludge is boiled with steam in lead-lined vessels, which decomposes it into pitch and sulphuric acid (30 to 40° Baumé). This acid has a dark brown color and is used for decomposing the soda sludge into creosote oil and sodium sulphate (glauber salt). The impure creosote containing tarry matters is mixed with the pitch separated from the acid sludge, and after washing with water to remove all traces of acid and alkali, the mixture is distilled with superheated steam. The purified lignite creosote is recovered as distillate (having a specific gravity of 0.940 to 0.980, and yielding 50 to 70 per cent soluble in caustic soda) and the lignite-tar pitch remains as residue. The extent to which the distillation is continued regulates the hardness and fusing-point of the pitch, which is much harder in consistency than that obtained from the direct distillation of lignite tar.¹

Lignite-tar pitch is characterized by the presence of phenols giving the diazo reaction, the absence of anthracene (as determined by the anthraquinone test), the absence of insoluble carbonaceous matter, the presence of small quantities of paraffine wax, and the fact that it is largely soluble in 88° naphtha. These tests distinguish it from coal-tar products.

According to Graefe,² lignite-tar pitch is almost completely soluble in benzol and turpentine, and less soluble in petroleum ether or naphtha. Donath and Margosches³ report that lignite-tar pitch is partly dissolved on boiling with a solution of alcoholic potash.

¹ "Die Braunkohlenteer-Industrie," by Dr. Ed. Graefe. Halle a. S., 1906; "Die Braunkohlenteerprodukte und das Oelgas," by Dr. W. Scheithauer, 1907; "Peat and Lignite, Their Manufacture and Uses in Europe," by E. Nystrom, Report 19, Dept. of Mines, Ottawa, Canada, 1908; "Die Schwelteere, Ihre Gewinnung und Verarbeitung," by Dr. W. Scheithauer, 1911; "Shale Oils and Tars," by Dr. W. Scheithauer, London, 1913; "Peat, Lignite and Coal," by B. F. Haanel, Report 299, Dept. of Mines, Ottawa, Canada, 1913; "Methods of Utilizing Lignite," by S. M. Darling, *J. Gas Lighting*, **131**, 456, 1915; "The Investigation of Six Samples of Alberta Lignites," by Haanel and Blizard, Report 331, Dept. of Mines, Ottawa, Canada, 1915; "The Brown Coal Distillation Industry of Germany," by D. R. Steuart, *J. Soc. Chem. Ind.*, **36**, 167, 1917.

² "Laboratoriumsbuch für die Braunkohlenteer-Industrie," p. 139, 1908.

³ *Chem. Ind.*, **27**, 220, 1904; also *J. Soc. Chem. Ind.*, **23**, 541, 1904.

Lignite-tar pitches conform with the following tests:

(Test 1)	Color in mass.....	Black
(Test 2)	Homogeneity.....	Uniform
(Test 3)	Appearance surfaceaged indoors one week.....	Dull
(Test 4)	Fracture.....	Conchoidal
(Test 5)	Lustre.....	Very bright when fresh
(Test 6)	Streak on porcelain.....	Black
(Test 7)	Specific gravity at 77° F.....	1.05-1.20
(Test 9c)	Hardness at 77° F., consistometer.....	10-100
(Test 9d)	Streak on porcelain.....	Greater than 100
(Test 10)	Ductility.....	Variable
(Test 13)	Odor on heating.....	Characteristic
(Test 14a)	Behavior on melting.....	Passes rapidly from a solid into a liquid state
(Test 15a)	Fusing-point (K. and S. method).....	90-250° F
(Test 16)	Volatile matter.....	Variable
(Test 17a)	Flash-point.....	Usually above 250° F.
(Test 19)	Fixed carbon.....	10-40%
(Test 21a)	Solubility in carbon disulphide.....	95-99%
(Test 21b)	Non-mineral matter insoluble.....	0-2%
(Test 21c)	Mineral matter.....	0-1%
(Test 22)	Carbenes.....	0-5%
(Test 23)	Solubility in 88° naphtha.....	75-95%
(Test 25)	Solubility in other solvents.....	Largely soluble in benzol and turpentine
(Test 28)	Sulphur.....	Less than 2.5%]
(Test 30)	Oxygen in non-mineral matter.....	2-5%
(Test 31)	Free carbon.....	Trace
(Test 32)	Naphthalene.....	Absent
(Test 33)	Paraffine.....	1-5%
(Test 35)	Sulphonation residue.....	5-15%
(Test 37)	Saponifiable constituents.....	0-5%
(Test 41)	Diazo reaction.....	Yes
(Test 42)	Anthraquinone reaction.....	No
(Test 43)	Liebermann-Storch reaction.....	No

Lignite-tar pitch is distinguished from wood-tar pitch by its associated sulphur and paraffine wax; from coal-tar pitch by its almost complete solubility in benzol and carbon disulphide; and from asphalt, resin pitch and fatty-acid pitches by the diazo reaction. On destructive distillation, lignite-tar pitch yields an oily distillate free from acid, whereas wood-tar pitch yields an aqueous distillate with an acid reaction.¹

In Germany, where practically all of the lignite-tar pitch is produced, it is used extensively for manufacturing cheap paints in consequence of its solubility in petroleum distillates.

¹ "Distinction between Lignite Pitch and Other Pitches," by E. Graefe, *Chem. Zeit.*, **30**, 298, 1906; "Native and Artificial Asphalts," by J. Marcusson and R. Eickmann, *Chem. Rev. Fett-Harz-Ind.*, **15**, 315, 1908; "Identifying Asphalts," by J. Marcusson, *Chem. Rev. Fett-Harz-Ind.*, **18**, 47, 1911; *J. Soc. Chem. Ind.*, **30**, 480, 1911; "Chemical Composition and Examination of Natural and Artificial Asphalts," by J. Marcusson, *Chem. Rev. Fett-Harz-Ind.*, **19**, 166, 1912.

CHAPTER XVI

SHALE TAR AND SHALE-TAR PITCH

THE most important deposits of asphaltic and non-asphaltic pyrobituminous shales have been considered in Chapter XII. Scotland is the home of the "shale oil" industry. According to Bacon and Hamor¹ four large Scottish companies are operating at present, with works at Pumpherston, Oakbank, Roman Camp, Broxburn, Dalmeny, Bathgate, Uphall, Addiewell, Deans and Seafield, Scotland. At Dorsetshire, England, shales are also being worked.

They are mined in the same manner as bituminous coal, by driving shafts, and then extending drifts radially. Considerable timbering is necessary, on account of the softness of the shale. When the seams are over 4 ft. in thickness, they are mined by the "pillar" and "stall" method, and when less than 4 ft. thick, by the "longwall" method.

The mineral as mined is hauled to the surface by power, and then run through a breaker, where the masses are broken into lumps measuring 4 to 6 in. in diameter. The breakers consist of a number of toothed iron discs mounted on two shafts revolving in opposite directions. The shale upon being crushed to the proper size, is next conveyed up an incline to the top of the retort.

Retorts Used for Distillation. The retorts used have been modified from time to time to increase their efficiency, add to their durability, hasten the speed of treatment, or to improve the quality of the output.

The basic principle underlying the modern retort was embodied to the patent originally granted to Young & Beilby,² illustrated in Fig. 83. This consists of four vertical cylinders mounted together, with a common hopper above. The upper portion of each cylinder is constructed of metal, and the lower portion of fire brick. The distillation takes place in the upper part of the retort where the shale is heated to 900° F. The shale is then subjected to a higher temperature (1300° F.) in the lower portion, which is in reality a gas producer, steam and air being admitted to convert the carbonaceous residue into carbon dioxide and carbon monoxide. This generates sufficient heat to effect the distillation in the upper portion

¹ "American Petroleum Industry," Vol. 2, p. 810.

² Eng. Pat. No. 4284 of 1881.

of the retort. The admission of air is carefully regulated to maintain the required temperature, without causing excessive combustion of the by-products. The steam also serves to convert the nitrogen into ammonia.

The charge gradually passes downward in the retort at a speed regulated by the periodical removal of the spent shale below. This type was first used at Oakbank, but was open to the criticism that it was difficult to

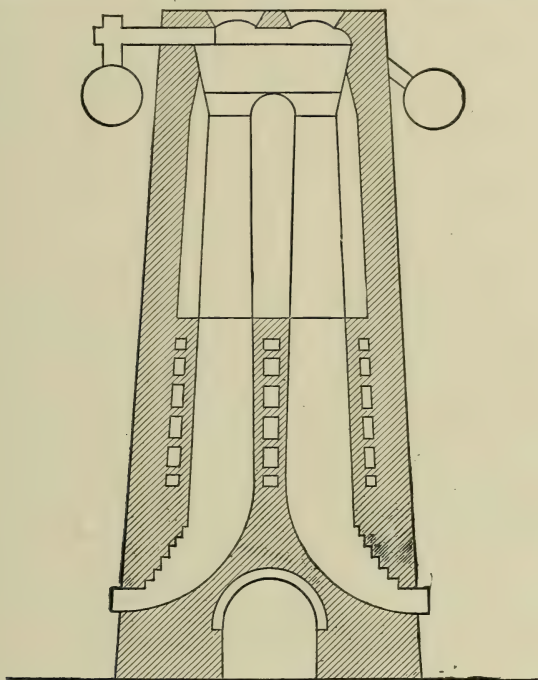

From "The American Petroleum Industry," by Bacon and Hamor.
 FIG. 83.—Young & Beilby Retort for Distilling Shales.

control the temperature of the upper and lower portions respectively. Thus, if the lower portion became too hot, the shale would fuse and the retort become choked up. This resulted in several modifications forming the basis of the modern retort which is embodied in four different types, viz.¹:

Pumpherston Type of Retort used at Pumpherston, Oakbank, Dalmeny Deans and Seafeld, Scotland. This was disclosed in Eng. Pats. No. 8371 of 1894, and No. 7113 of 1895, granted jointly to Bryson and Fraser (of the Pumpherston Oil Co., Limited) and to Jones (of the Dalmeny Oil Works); also Eng. Pat. No. 4249

¹"American Petroleum Industry," by Bacon and Hamor, Vol. 2, p. 816; also "Shale Oils and Tara," by Scheithauer, p. 41, 1913.

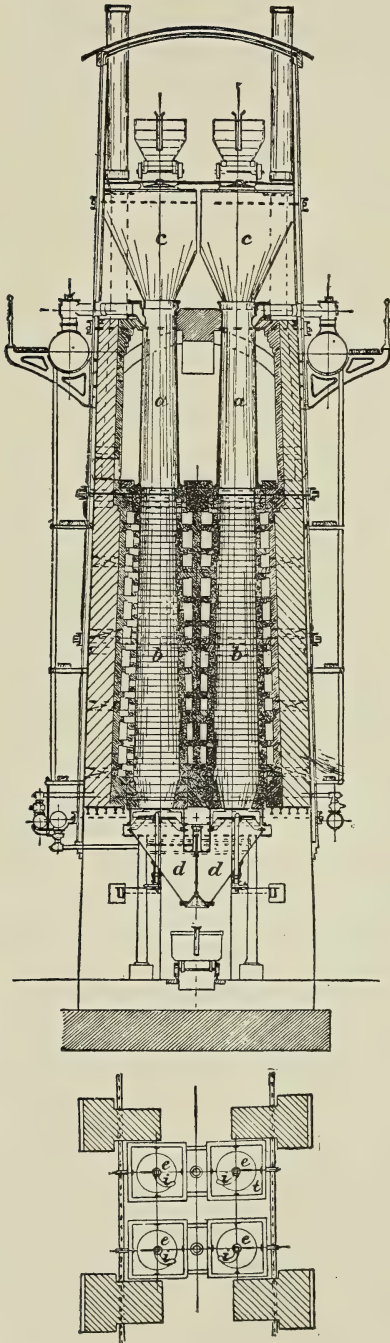

of 1897, granted to Bryson. The shale is prevented from fluxing and choking up the retort by keeping it moving continuously instead of intermittently as in the Young and Beilby retort. This is brought about by supporting the column of shale on a disc, from which a revolving scraper discharges the consumed shale into the hopper below. This retort is illustrated in Fig. 84. The shale is introduced into the charging hopper, *c* whence it passes into the upper cast-iron portion of the retort *a* in which the actual distillation takes place. The shale then slowly works its way into the lower portion *b*, constructed of fire-brick, and finally into the lower hopper *d* extending underneath several retorts, converging in such a manner that a single line of rails running below the centre will permit the exhausted shale to discharge into small cars. *e* represents the metal disc at the bottom of the retort, and *i* the revolving arm or scraper. Steam is introduced into the lower portion of the retort *b* a short distance above the disc *e*, and the gaseous products of distillation are burned with air in the external flues to maintain the retort at the proper temperature.

Young and Fyfe Type of Retort used at Bathgate, Uphall and Addiewell, Scotland. This is embodied in Eng. Pats. No. 13,665 of 1897, and No. 15,238 of 1899 issued to William Young and John Fyfe, and consists of a large multiple charging hopper bolted to a vertical metallic section which in turn connects with a lower fire-brick section of the same diameter, having a spacious combustion chamber at the bottom. The shale is introduced continuously into the retort from the hoppers by means of two sets of cams attached to rocking-shafts which rise and fall alternately, thus obviating the stoppage of the retort due to the shale fusing fast to the entrance of the metallic section. A mechanical device is also provided at the lower end of each retort to effect a continuous discharge of the spent shale into

FIG. 84.—Pumpherson Retort for

the combustion chamber, which receives the spent shale in a highly heated condition, and enables the carbonaceous matter to be consumed by introducing steam and air. The danger of the shale fluxing and attaching itself to the side-walls of the retort is thus minimized.

Henderson Type of Retort used at Roman Camp and Broxburn, Scotland. This is described in Eng. Pats. No. 6726 of 1889, and 26,647 of 1901, granted to N. M. Henderson (of the Broxburn Oil Co., Limited), and illustrated in Fig. 85. Four retorts are mounted together. The upper cast-iron portion (*a*) is supported directly by the fire-brick section *b*, the joint between the two being formed so

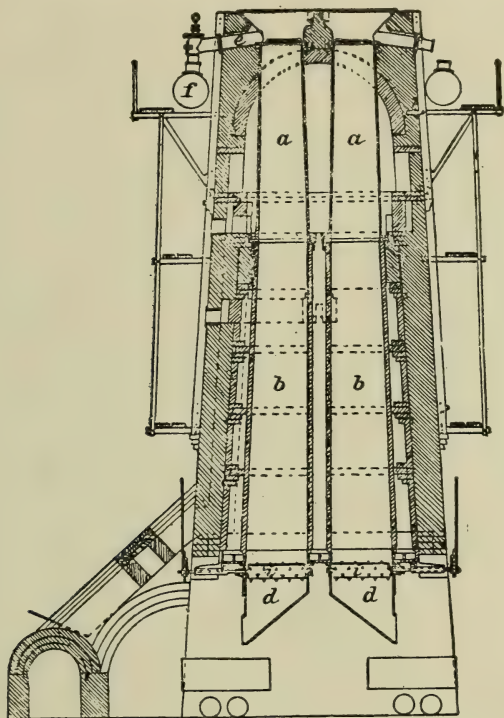

FIG. 85.—Henderson Retort for Distilling Shales.

as to obviate leakage, which is the source of more or less trouble in the other types. This retort is made comparatively long to heat the shale gradually and thus diminish wear and tear on the lining. The column is kept in continuous motion by a pair of revolving toothed rollers *i* at the bottom, which discharge the spent shale into a metal hopper *d*, whence it passes into small cars. The gases escape through the flue *e* into the pipe *f*. The yield of ammonia is high and the recovered tar of good quality.

Del Monte Type of Retort Used at Dorsetshire, England. This retort is heated internally by burning a portion of the non-condensable gases in a flue extending through the centre of the charge of shale. The retort is inclined at an angle of

15° to the horizontal, and the shale introduced at the lower end and worked upward by a spiral screw. The non-condensable gases are passed into the upper portion of the retort together with sufficient air to support combustion and forced downward to the cooler end where the products of distillation are partly condensed by coming in contact with the cold shale. The shale is distilled at the lowest possible temperature, for the purpose of increasing the yield of tar.¹

Methods of Recovering Shale Tar. The vapors leaving the retorts are first passed through an "economizer," consisting of a tower filled with pipes, around which cold water is circulated and thus preheated for use in the steam boilers (see Fig. 60). The vapors are then passed through an air-condenser (Fig. 59) which separates most of the tar and ammoniacal liquor. They are next passed through a scrubber (filled with a checker-work of wood), and finally through a naphtha scrubber where they are washed with the "intermediate oil" obtained in distilling the shale tar (having a high boiling-point and a specific gravity of 0.84 to 0.86) which extracts any light naphtha not previously condensed (about 2 gal. per ton of shale). The naphtha is separated from the scrubbing oil by heating the mixture moderately in a still, and condensing the distillate (having a specific gravity of 0.73).

The crude tar and ammoniacal liquor are allowed to stand in a suitable container, whereupon the tar rises to the surface on account of its lower gravity, and is drawn off. The crude tar is generally termed "shale oil," but this name is just as inappropriate as the expression "oil shale," often used to designate the shale (see p. 158).

Products Obtained and Their Yields. Upon destructively distilling the Kimmeridge Shales of England and the Lothian Shales of Scotland, the following products are obtained:

- (1) Non-condensable gases, averaging 3000 cu. ft. per ton.
- (2) Ammoniacal liquor yielding an average of 45 lbs. ammonium sulphate per ton.
- (3) Shale tar, averaging 25 gal. per ton.
- (4) Light naphtha, averaging 2 gal. per ton.
- (5) Spent shale, averaging between 80 and 85 per cent of the raw shale, and containing approximately 2½ per cent unconsumed carbon.

The non-condensable gases are burned under the retorts, and the spent shale discarded, as it has no further value. The valuable products are the light naphtha, the shale tar and ammonium sulphate.

The ammoniacal liquor separated from the tar is treated with steam under a pressure of 20 to 30 lbs. in a tower filled with baffle-plates. The liquor is run in at the top and the steam introduced at the bottom. The

¹ W. H. Mansfield, *J. Inst. Petrol. Techn.*, **2**, 162, 1916; *Engineering*, **101**, 164, 1916.

ammonia is expelled in the gaseous state and recovered by passing it into sulphuric acid contained in a vessel known as a "cracker box." The acid used for this purpose is usually the waste product from the refining process. Crystals of ammonium sulphate separate when the liquor becomes sufficiently concentrated, and after being dried are marketed as such. In this manner the ammonia is separated from the other nitrogenous bases, including pyridine, contained in the aqueous liquor.

The following table gives the minimum and the maximum yields of dehydrated shale tar in gallons, and ammonium sulphate in pounds per ton of shale, obtained from the most important shale deposits in different parts of the world.¹ As a matter of interest, figures are included showing the yields from grahamite (West Virginia), albertite (New Brunswick), stellarite (Nova Scotia), coorangeite (Australia), torbanite (Scotland), and pyropissite (Halle, Germany), although these are no longer distilled commercially because most of the deposits have long been exhausted.

	Yield of Shale Tar (in Gallons).	Yield of Ammonium Sulphate (in Pounds).
Grahamite (West Virginia).....	170-200
Albertite (New Brunswick).....	90-112	65
Stellarite (Nova Scotia).....	50-130
Torbanite (Scotland).....	90-130
Coorganite (Australia).....	80-120
Pyropissite (Halle, Germany).....
Lothian shale (Scotland).....	10-55	6-70
Kimmeridge shale (England).....	10-40	10-50
Coorangitic shale (New South Wales).....	14-150	20-30
Orepuki shale (New Zealand).....	20-40
Albert shale (New Brunswick).....	30-51	67-111
Arcadian shale (Nova Scotia).....	4-23	9-40
Shales (Eastern United States).....	4-45	0-10
Utah shales.....	6-10	40-50
Colorado and Wyoming shales.....	10-68	22-34

Properties of Shale Tar. Shale tar usually appears black in mass with a greenish fluorescence. It is similar in composition to lignite tar, although differing from the latter in containing a larger percentage of nitrogen (1.1 to 1.5 per cent). Members of the paraffine and olefine series constitute 80 to 90 per cent by weight of the tar, and small quantities of cresols and phenols are present.

Dehydrated shale tar tests as follows:

- (Test 1) Color in mass..... Brownish black with a
greenish fluorescence
- (Test 7) Specific gravity at 77° F..... 0.85-0.95

¹"American Petroleum Industry," by Bacon and Hamor, Vol. 2, p. 832; "Oil Resources of Black Shales of the Eastern United States," G. H. Ashley, Bulletin 641-L, U. S. Geol. Survey, Wash., D. C., 1917.

(Test 9)	Hardness or consistency.....	Salve-like to buttery
(Test 15a)	Fusing-point (K. and S. method).....	60-90° F.
(Test 16)	Volatile matter at 500° F., 4 hrs.....	80-90%
(Test 17a)	Flash-point (Pensky-Martens tester).....	20-60° F.
(Test 19)	Fixed carbon.....	5-10%
(Test 21a)	Soluble in carbon disulphide.....	98-100%
(Test 21b)	Non-mineral matter insoluble.....	0-2%
(Test 21c)	Mineral matter.....	0-1%
(Test 22)	Carbenes.....	0-2%
(Test 23)	Soluble in 88° naphtha.....	95-100%
(Test 28)	Sulphur.....	1.5-2.5%
(Test 29)	Nitrogen.....	Tr.-1%
(Test 30)	Oxygen.....	1-5%
(Test 31)	Free carbon.....	0-2%
(Test 33)	Paraffine.....	5-15%
(Test 35)	Sulphonation residue.....	15-35%
(Test 37)	Saponifiable constituents.....	0-2%
(Test 41)	Diazo reaction.....	Yes
(Test 42)	Anthraquinone reaction.....	No
(Test 43)	Liebermann-Storch reaction.....	No

The percentage of phenols contained in the shale tar is very much smaller proportionately than that present in peat or lignite tars. Shale tar is distinguished from the latter by containing larger percentages of nitrogen and sulphur, and smaller percentages of oxygen, paraffine and phenols respectively.

Refining of Shale Tar. Shale tar may be distilled either intermittently or continuously. In either case the process consists in heating the tar in a still to expel the moisture, whereupon either plain or superheated steam is introduced through a perforated pipe under a pressure of between 10 and 40 lbs. The tar is evaporated to dryness and the following products separated:

(1) Non-condensable gases ranging from 1 to 2 cu. ft. for each gallon of shale tar.

(2) Light naphtha having a specific gravity of 0.74 to 0.76.

(3) So-called "once-run oil" or "green oil" representing the fraction between the light naphtha and coke.

(4) A residue of coke approximating 3 per cent by weight of the shale tar.

The steam is shut off towards the end of the distillation, after the "once-run oil" has passed over.

The stills used in Scotland are of the vertical type from 2000 to 2500 gal. capacity, constructed of a hemi-spherical cast-iron bottom, and a soft malleable-iron cylindrical body to which is attached a dome-shaped top bearing the exit pipe. Each still is connected with its own condenser.

In the continuous distillation process termed the "Henderson Process"¹ a battery of three horizontal stills and one vertical pot-still is used. The tar is first led into the middle still where the naphtha is distilled off,

¹ Eng. Pat. No. 13,014 of 1885.

and the residue caused to flow continuously into the two side stills. These are heated higher than the centre still, causing the once-run oil to distil over continuously. (See continuous distillation of petroleum, p. 273.) The residues from these second stills are led into the pot-still, where they are evaporated to dryness, the distillate being condensed and united with the once-run oil. Several pot-stills are used, since the red-hot coke must be allowed to cool before it can be removed, which prevents this part of the process being continuous.

The once-run oil is refined by agitating it with sulphuric acid at 100° F. by compressed air. The acid sludge is run off, the oil washed with water, and then treated in another agitator with caustic soda in a similar manner.

The refined once-run oil is fractioned either by an intermittent or continuous steam distillation process, the following products being recovered:

- (1) Heavy naphtha varying in gravity between 0.75 and 0.77.
- (2) Illuminating oil, varying in gravity between 0.78 and 0.85, and having a flash-point of 125° F.
- (3) Intermediate or gas-oil varying in gravity between 0.85 and 0.87, and having a flash-point higher than 150° F. This is used for manufacturing water-gas or enriching illuminating gas (p. 231).
- (4) Lubricating oil having a gravity from 0.87 to 0.91.
- (5) Crude paraffine wax which is purified by re-crystallization or "sweating," having a fusing-point between 110 and 130° F.
- (6) Still grease, which represents the distillate passing over at the close of the distillation.

The various distillates, with the exception of the still grease are refined further with sulphuric acid and caustic soda, similar to the method used for treating the once-run oil. The crude paraffine wax is refined by the sweating process as described on p. 307.

The following yields are obtained from Scotch shale tar:

Heavy and light naphthas.....	3-6%
Illuminating oil.....	20-30%
Intermediate or gas-oil.....	10-25%
Lubricating oil.....	15-20%
Soft paraffine scale.....	3-5%
Hard paraffine wax.....	7-9%
Non-condensable gases.....	3-5%
Acid and soda sludges and losses.....	20-25%

The acid and soda tars obtained from the various refining processes are mixed together in such proportions that the free acid and alkali will exactly neutralize each other. The resulting sludge is ordinarily used as fuel for the stills, but experiments have been made to convert it

into pitch suitable for use as a wood preservative, pipe-dip, or the base of bituminous paints. Comparatively little has been accomplished in this direction, probably due to the fact that other products are available for these purposes, costing but little more and possessing superior weather-resisting properties. "Shale-tar pitch," is very similar in its physical properties and composition to lignite-tar pitch (see p. 215).

CHAPTER XVII

COAL TAR AND COAL-TAR PITCH

UNDER the headings "Coal tar" and "Coal-tar pitch," will be included the tars and corresponding pitches recovered as by-products from bituminous coal in:

- (1) Gas works;
- (2) Coke ovens;
- (3) Blast furnaces;
- (4) Gas producers.

Water-gas tar and water-gas-tar pitch have been included by some writers within the scope of the terms coal tar and coal-tar pitch respectively, but in this treatise they will be considered separately since they differ in their composition and properties, due to the use of petroleum products in their manufacture, as described on p. 258.

It is estimated that of the total production of coal tar in the United States in 1916 (about 225,000,000 gal.), 22 per cent (or 50,000,000 gal.) was obtained as a by-product in the manufacture of coal gas in gas-works, and the balance as a by-product from coke ovens. The amounts obtained from gas producers and blast furnaces are practically negligible. The three main sources of coal tar in the order of their importance are: first, coke-oven coal tar which is continually increasing in quantity; second, horizontal retort gas-works coal tar, which has not materially increased during the past few years on account of the growing popularity of water gas; and third, a comparatively smaller, but gradually increasing amount of vertical retort gas-works coal tar.

Bituminous coals only are suitable for the production of coal tar. Cannel and anthracite coals will not answer, since the former distills at too low a temperature, and the latter contains insufficient volatile matter. Experiments show that cannel coals from Missouri and Illinois on distillation yield 28.1 to 69.7 gal. tar and 3500 to 8100 cu. ft. rich gas per ton. Between 450 and 500° C., the maximum gasolene is produced, between 550 and 650° C., the maximum kerosene, and above 650° C. soft paraffines, heavy lubricating oils, kerosene and asphalt-

like bodies.¹ Bituminous coals are known as "gas coals" when used for manufacturing illuminating gas, and "coking coals" when used for coking. Western Pennsylvania, West Virginia, Virginia, eastern Kentucky and Tennessee produce most of the bituminous coals used for these purposes, and they comply with the following characteristics:

Air-dry loss of coarse material.....	1	-5%
Moisture at 105° C. (powdered material).....	1.5-7.0%	
Volatile matter on ignition.....	20	-40%
Fixed carbon.....	50	-75%
Ash.....		Less than 15%
Sulphur.....		Less than 2%
Hydrogen.....	4.5-5.5%	
Carbon.....	65	-85%
Nitrogen.....	1	-2%
Oxygen.....		5-15%

Very little is known regarding the chemical composition of the bituminous coal itself, due to the difficulty in converting the coal into recognizable derivatives, and because of its slight solubility in the usual solvents for bituminous materials. On subjecting coal to high temperatures, the bodies present decompose into simpler substances which fail to give any clue as to their original structure and composition. Recent researches lead to the conclusion that coal is essentially a conglomerate of cellulose decomposition products admixed with altered resins and gums originally present in the plants from which the coal was derived.

The substances having the highest solvent action are pyridine,² which dissolves 15 to 35 per cent by weight of bituminous coal; aniline,³ which dissolves 20 to 40 per cent; phenol,⁴ which extracts 25 to 40 per cent at a temperature of 110° C.; and quinoline,⁵ which extracts 30 to 50 per cent at its boiling-point. Anthracite coal is scarcely acted upon by these solvents.⁶

A method has recently been devised for converting coal into soluble derivatives⁷ by subjecting the finely pulverized coal suspended in water to the action of ozone at room temperature. It is stated that at the end of two days, 92 per cent of the coal dissolves, forming a solution having a dark brown color. It would seem that some very promising results may be obtained by this method.

It has been shown⁸ that the soluble portion of bituminous coal when subjected

¹ "Studies in the Production of Oils and Tars from Bituminous Materials," J. C. Ingram, S. of M. and Metallurgy, Univ. of Mo., Bull. 4, Vol. 3, May, 1917.

² Bedson, *J. Soc. Chem. Ind.*, **18**, 739, 1899; Baker, *J. Soc. Chem. Ind.*, **20**, 789, 1901; **27**, 147, 1908; "The Action of Solvents on Coal," Anonymous, *J. Soc. Chem. Ind.*, **35**, 1136, 1916; A. Wahl, "The Solvents of Coal," Bull. Soc. Chim., **21**, 76, 1917.

³ Vignon, *J. Soc. Chem. Ind.*, **33**, 633, 1914.

⁴ Frazer and Hoffman, Tech. Paper 5, Bureau of Mines, U. S. Dept. of Interior, Wash., D. C., 1912; Parr and Hadley, *J. Soc. Chem. Ind.* **34**, 213, 1915.

⁵ Vignon, *J. Soc. Chem. Ind.*, **33**, 633, 1914.

⁶ *J. Soc. Chem. Ind.*, **35**, 634, 1917.

⁷ Franz Fisher, Ber., **49**, 1472, 1916; *Engineering*, **103**, 296, 1917; *J. Ind. Eng. Chem.*, **9**, 620, 1917; *Chem. Abs.*, **11**, 1739, 1917.

⁸ Clarke, Wheeler and Platt, *Chem. Soc. Trans.*, **103**, 1713, 1913; *J. Soc. Chem. Ind.*, **32**, 969, 1913.

to destructive distillation yields petroleum-like bodies, whereas the insoluble portion yields phenols and their derivatives.¹

D. T. Jones² examined the tars derived from the destructive distillation of bituminous coal in vacuo at very low temperatures (below 450° C.). These were then subjected at atmospheric pressure to successively increased temperatures up to 800° C. Unsaturated hydrocarbons, naphthenes, paraffines, phenols, aromatic hydrocarbons and pyridines were found to be present in the low-temperature tar, whereas benzol and its homologues, naphthalene, anthracene, phenanthrene and the solid aromatic bodies were absent. As the temperature was increased, the naphthenes, paraffines, and unsaturated hydrocarbons were transformed into olefines. As the temperature was further increased, the olefines were in turn transformed into benzene and its homologues. The percentage of olefines appears to reach a maximum at 550° C., and a minimum at 750° C., at which latter temperature hydrogen and naphthalene are rapidly evolved, as well as methane. The conclusion reached is that ordinary coal tar obtained from bituminous coal at high temperatures results chiefly from the decomposition of the tar previously formed at lower temperatures.

The commercial processes for obtaining coal tar will now be considered.

Production of Gas-works Coal Tar. In manufacturing illuminating gas, bituminous coal is heated in comparatively small fire-clay retorts, of D-shaped, oval or round cross-section about 16 to 24 in. in diameter. The D-shaped retort is ordinarily used in modern gas-works because it is least liable to distortion under the action of heat, and moreover presents the greatest area at its base, enabling the contents to be heated more rapidly. In some cases the retorts are "single-ended," measuring 8 to 9 ft. in length, but modern practice favors the use of "double-ended" retorts composed of three sections joined together, measuring 15 to 25 ft. over all. In the single-ended retort a metal mouth-piece is bolted to one end, to which in turn the gas outlet pipe is fastened. With the double-ended retort, metal mouth-pieces are bolted fast to both ends. From 6 to 9 retorts are set together in a common brick setting, constituting a "bench" which is heated by a single furnace.

The retorts are supported in either a horizontal, inclined or vertical position. The inclined or vertical retorts seem to meet with greater favor since they avoid overheating, prevent the formation of "free carbon" in the tar, and at the same time permit the coke to be handled by gravity. The vapors leave horizontal retorts at 600 to 800° F. and the vertical and inclined retorts at 300 to 400° F.

The retorts are heated with water-gas obtained by passing air and

¹ See also Jones and Wheeler, *Chem. Soc. Trans.*, **107**, 1318, 1915; *J. Soc. Chem. Ind.*, **34**, 1043, 1915.

² "The Thermal Decomposition of Low Temperature Coal-tar," *J. Soc. Chem. Ind.*, **26**, 3, 1917; see also "The Primary Volatile Products of the Carbonization of Coal," by H. C. Porter, *Chem. Abs.*, **11**, 2537, 1917.

steam through incandescent coke beneath the "bench." The coke used for this purpose is derived as a residue from a previous charge of bitu-

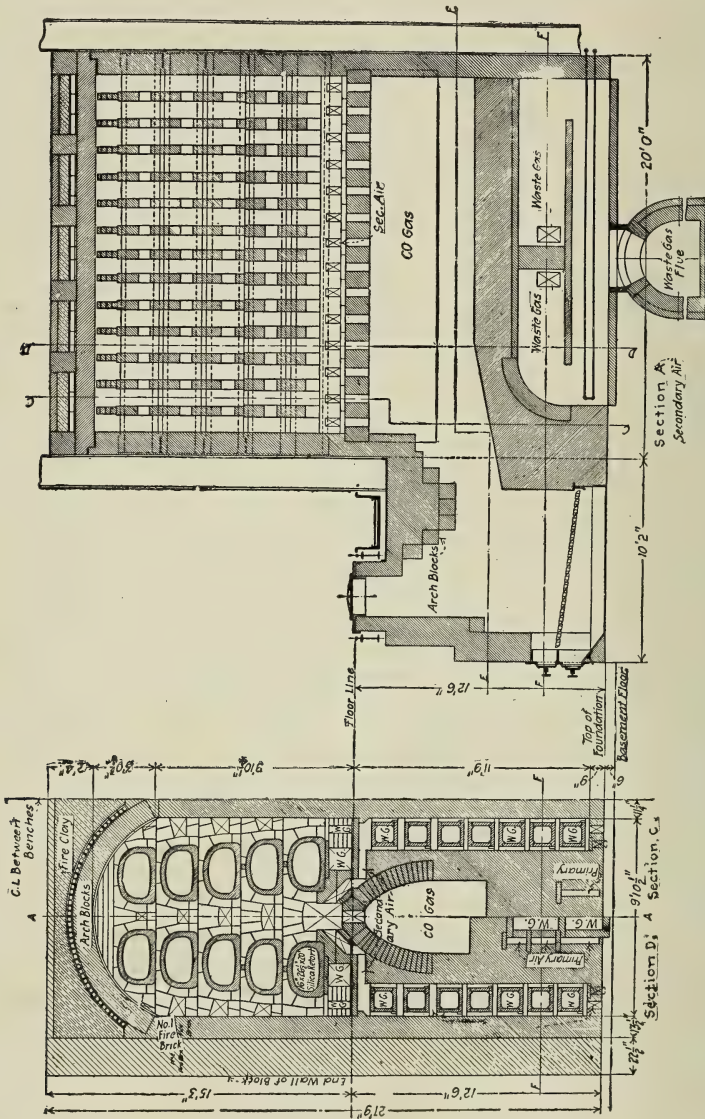

From "Coal and Coke," by F. H. Wagner.
 Fig. 86.—Horizontal Gas-Works Retort.

minous coal, amounting to 15 to 25 per cent of the total coke produced. The water-gas is burnt in flues surrounding the retorts and the process of combustion controlled by the introduction of air. This method of

firing results in a higher and more uniform temperature with the minimum consumption of fuel. The temperature in the combustion chamber ranges from 2800 to 3200° F., and in the flues surrounding the retorts from 1900 to 2200° F. An improved installation of horizontal retorts is shown in Fig. 86, inclined retorts in Fig. 87, and vertical retorts in Fig. 88. Continuously operating vertical retorts are now being adopted extensively, in which the coal is fed through the retort in a constant stream, the coke being withdrawn continuously at the bottom. These include the Woodall-Duckham and Glover-West types.

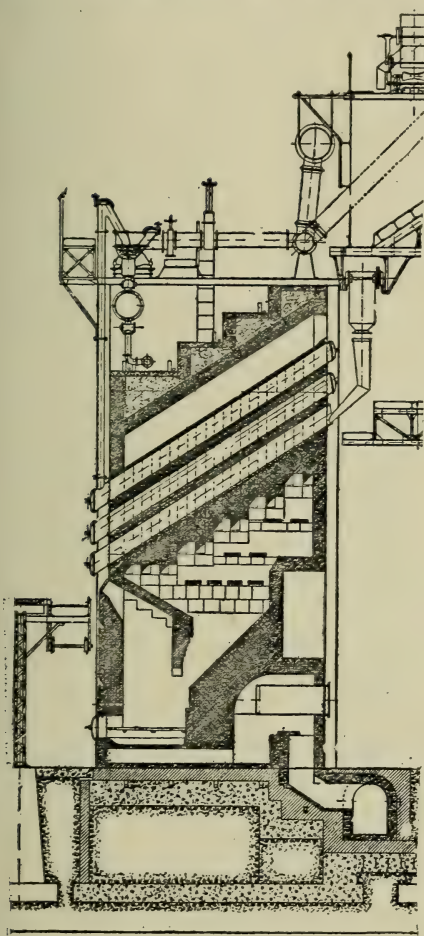

From "Coal and Coke," by F. H. Wagner.

FIG. 87.—Inclined Gas-Works Retort.

retorts are set at an angle between 25 and 35° which is sufficient to enable the coal to feed into the lower end, where it is held in place by a metal cover. In the inclined and vertical types the volatile constituents are withdrawn from the upper end.

The vapors are subjected to the highest temperatures in the hori-

zontal retort, due to the longer contact with the heated internal surfaces, which results in a larger percentage of free carbon, and a tar of higher specific gravity.

Methods of Recovering Gas-works Coal Tar. The volatile products pass from the retort into the hydraulic main (see p. 174), which forms a water-seal, permitting any retort to be charged, and at the same time preventing the gas generated in the other retorts escaping through the

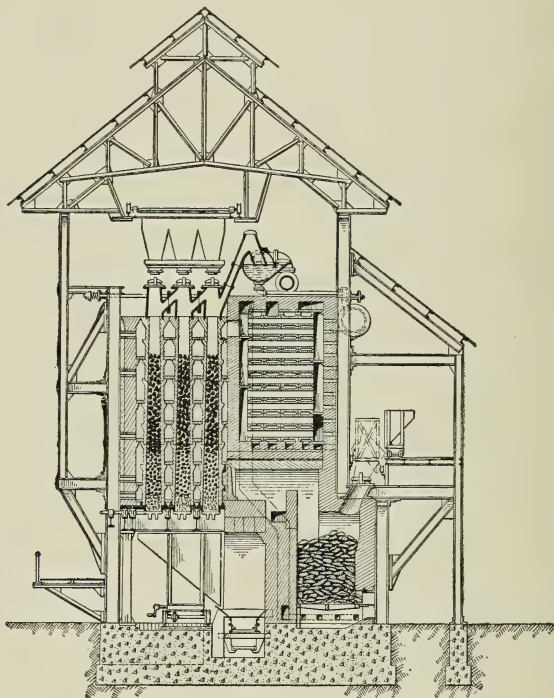

FIG. 88.—Vertical Gas-Works Retort.

open one. The hydraulic main reduces the temperature of the vapors to 130 to 160° F.

The methods for separating tar from the gaseous constituents have already been described on page 174. After leaving the hydraulic main the vapors are subjected to the following treatment in modern gas-works:

(1) The gases are passed through a "primary condenser" which may either be air-cooled or water-cooled, or both (see p. 175).

(2) The gases are then passed through a tar-extractor, usually of the P. & A. type (Fig. 69).

(3) Next passed through an exhauster to relieve the pressure on the retorts and force the gases through the ensuing train of apparatus.

(4) The gases are next passed through two "scrubbers" (p. 177), preferably of the rotary type illustrated in Fig. 65. In the first scrubber the gases are washed with a heavy tar oil, such as anthracene oil, to remove the naphthalene, and in the second with an alkaline solution of ferrous sulphate to remove the cyanogen.

(5) The gases are then cooled to about 60° F. by passing them through a "secondary condenser," similar to the first one.

(6) The ammonia is next removed by passing the gases through a third scrubber through which a stream of water is allowed to trickle. Formerly a tower scrubber filled with a checker-work of wooden boards (Fig. 63) was used for this purpose, but this is being replaced by a rotary scrubber similar to that used for extracting the naphthalene and cyanogen.

(7) The last step consists in passing the gases through a series of "purifiers," consisting of low cylindrical chambers filled with trays or sieves. Some of the purifiers are filled with slaked lime to remove carbon dioxide and a portion of the sulphur compounds, and others with iron oxide to remove the remainder of the sulphur compounds (mostly hydrogen sulphide).

The following percentages of tar are collected from the hydraulic main, condenser, washer and scrubber, also the tar extractor respectively:

Hydraulic main.....	61%
Condenser.....	12%
Washer and scrubber.....	15%
Tar extractor.....	12%
Total.....	100%

The operations which take place in the final handling of illuminating gas before it enters the mains, cease to be of interest in relation to the production of tar, and will accordingly be omitted.

In the United States, temperatures to which the retorts are heated vary from 900 to 1500° C. Between 900 and 1000° C. is known as low temperature treatment, from 1000 to 1100° C. medium temperature, and from 1100 to 1500° C. high temperature treatment. In England the average temperature is 1100° C. In Germany horizontal retorts are heated between 1000 and 1100° C., and inclined retorts between 1100 and 1200° C. The quantity and yield of the tar depend largely upon the temperature (see p. 168). In the low temperature production of illuminating gas, an average of 16 gal. of tar is produced per ton of coal, and in high temperature processes an average of 8. The maximum variation ranges between 4 and 20 gal. of tar per ton. High-temperature processes are preferable, as they increase the yield of gas, but have the disadvantage of reducing its illuminating power. It is often necessary, therefore, to enrich the illuminating gas resulting from the high temperature processes by one of the following methods:

(1) Heating the gas with a portion of the tar recovered during its manufacture, either by passing both together through superheaters, or else cracking the tar alone and then mixing the resulting permanent gases with the low illuminating power coal gas.

(2) Mixing the coal gas with oil gas obtained by cracking crude petroleum at a high temperature. (See p. 259).

(3) Saturating the coal gas of lower illuminating power with vapors of volatile hydrocarbons such as benzol, etc.

(4) Mixing the coal gas with carburetted water gas. (See p. 256.)

The following represent the yields from an average grade of bituminous coal in manufacturing illuminating gas.

Gas.....	17% (10,000 cu. ft.)
Aqueous liquor.....	8%
Tar.....	5%
Coke.....	70%
Total.....	100%

Of course, these figures are subject to variation, and depend upon the quality of bituminous coal used, the temperature at which it is distilled, etc. Thus the yield of gas per ton of rich coal will vary from 5000 to 15,000 cu. ft., and the residual coke from 55 to 75 per cent.

The illuminating power of the gas depends upon the quantity of hydrocarbons present, including both unsaturated and saturated. The hydrogen and carbon monoxide act as combustible diluents, and do not contribute to the luminosity of the flame. The carbon dioxide, nitrogen, and oxygen may be regarded as impurities. The chief unsaturated hydrocarbons present are ethylene, butylene, acetylene, benzol and naphthalene, and the chief saturated hydrocarbons are methane and ethane. In certain cases benzol is extracted from the coal gas, being marketed as "gas-benzol," which constitutes a most valuable raw material for manufacturing coal-tar dyes, chemicals and drugs. High-grade gas coal yields approximately $\frac{1}{2}$ to 1 per cent by weight of gas-benzol, equivalent to 2-3 per cent by weight of the coal gas.¹

The aqueous liquor, known as "gas liquor," contains a series of ammonium compounds dissolved in water, including the sulphide, carbonate, chloride, thiocyanide, sulphate, thiosulphate and ferrocyanide. The ammonia is derived from the nitrogen in the coal, only part of which is carried in the aqueous liquor. The following table will give a general idea of the distribution of nitrogen among the various products of destructive distillation:

Nitrogen in gas.....	0.72%
Nitrogen in aqueous liquor:	
As ammonia.....	14.50%
As cyanides.....	1.56%
Nitrogen in tar.....	34.54%
Nitrogen in coke.....	48.68%
	100.00%

¹ Applebee, *J. Soc. Chem. Ind.*, **12**, 635, 1917.

The tar collected from the hydraulic main, condenser, washers and scrubbers is run into wells constructed of metal or masonry, sometimes heated with steam-coils (p. 181) and allowed to settle as long as possible, to permit the aqueous liquor, which is lighter than the tar, to rise to the surface, where it is drawn off and treated separately to recover the ammonium compounds. The well-settled gas-works tar carries between 4 and 10 per cent of water. In exceptional cases the water may run as high as 40 per cent, although this is not regarded with favor. The settled tar is shipped direct to the distilling plant, where it is dehydrated.

Production of Coke-Oven Coal Tar. As stated previously, about 78 per cent of the coal tar produced annually in the United States is obtained from coke-ovens equipped to recover by-products. This only represents between 40 and 50 per cent of the total quantity of bituminous coal converted into coke. The remaining 50 to 60 per cent is coked in brick "beehive" ovens, constructed in the form of a beehive, and not adapted to recover the gas, ammonia or tar, which are allowed to burn away through an opening in the top of the oven, thus constituting a reckless waste of our national resources, running into many millions of dollars annually. For years this wasteful practice remained unchecked, but happily the present tendency is to replace the beehive ovens with types adapted to recover by-products, and it is probably only a matter of a few years more before all the coke-ovens will be equipped to recover the gas, ammonia and tar.

In European countries, on the other hand, where the tendency has always been towards a greater economy, coke-ovens have long been perfected to recover these by-products. In this connection it must be borne in mind, whereas it is absolutely necessary to remove the tar in manufacturing coal gas for illuminating purposes, this does not prove to be the case where the coal is converted into coke for metallurgical industries. This, and the comparative cheapness of bituminous coal in the United States, also the low price commanded by the by-products until recently, will account for the laxity in conserving them.

The annual output of tar from by-product coke-ovens in the United States is given in the following figures:

1907.....	53,995,795 gallons
1908.....	42,720,609 "
1909.....	60,126,006 "
1910.....	66,303,214 "
1911.....	69,410,599 "
1912.....	94,306,583 "
1913.....	115,145,025 "

1914.....	109,901,315 gallons
1915.....	138,414,601 "
1916 (estimated).....	175,000,000 "
1917 (estimated).....	250,000,000 "

The by-product coke-ovens now used in the United States include the Koppers, Semet-Solvay, United-Otto, and Otto-Hoffman types. The Simon-Carvés coke-oven is used to a large extent abroad, in addition to the foregoing.¹

The temperature of coking varies between 1000 and 1200° C., and rarely above the latter inside the retort. The external temperature of the retort may run as high as 1700° C. According to White,² the adaptability of coal for coking purposes is indicated with a fair degree of certainty by the ratio of hydrogen to oxygen, together with the percentage of fixed carbon calculated on the moisture-free basis. Practically all coals with an H : O ratio of 59 per cent or over, and less than 79 per cent of fixed carbon, possess that quality of fusion and swelling necessary to good coking. Bituminous coals with a ratio down to 55 will produce a more or less satisfactory coke but coals with a ratio as low as 50 are unsuitable for coking purposes.

The present systems of by-product oven construction resolve themselves into two types depending upon whether the flue construction is horizontal or vertical. In either types the coking takes place in a narrow, retort-shaped chamber about 33 ft. long, from 17 to 22 in. wide, and about 6½ ft. high. The width of the chamber averages 19 ft., which has proven suitable for completing the coking within 24 hours. The retort holds between 12 and 14 tons of coal.

The ends of the retort are closed by means of iron doors lined with fire brick, which after being closed as tightly as possible are luted with clay to prevent the entrance of air. The coal is charged into the top of the oven, then pushed into place and leveled by mechanical devices. At the end of the coking, the doors are opened and the coke removed by a ram, the red-hot coke being immediately quenched with water.

The number of ovens in a battery varies between 40 and 100, depending upon the type of construction. The oven walls are constructed of fire brick containing about 95 per cent of silica, which on account of its very high fusing-point enables the ovens to be worked at high tem-

¹ "Coke-oven Tars of the United States," by Prévost Hubbard, Circular 97, Office of Public Roads, U. S. Dept. of Agr., Wash., D. C., Feb. 7, 1912; "By-products Recovered in the Manufacture of Coke," by W. H. Childs, *Amer. Iron and Steel Inst.*, N. Y., May 26, 1916.

² "The Effect of Oxygen on Coal," Bulletin No. 29, Bureau of Mines, Wash., D. C., 1916.

peratures, and at the same time proves to be an excellent conductor of heat.¹

The coking in the by-product oven is in reality a destructive distillation process, the heat required being supplied by burning a portion of the gases evolved. A large excess of gas is produced amounting to between 40 and 60 per cent of the total.

The following is a brief description of the more important types of by-product coke-ovens used in the United States:

Semet-Solvay Coke-oven. This is composed of a vertical retort heated on either side by sectional horizontal flues, in which the gases undergo combustion. The flues are constructed in small units which dovetail together, and constitute the lining of the retort, thus providing a rapid transmission of heat through the walls. The gases circulate from the top downward, as illustrated in Fig. 89. The gases

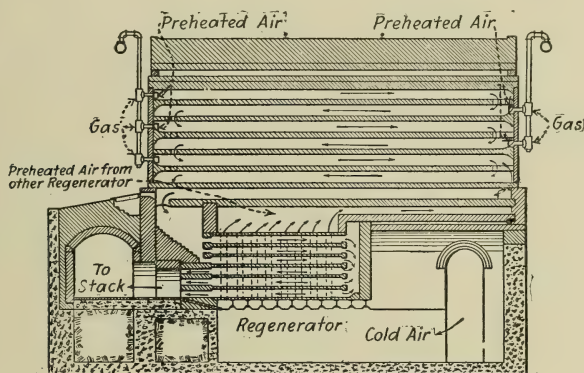

From "Coal and Coke," by F. H. Wagner.

Fig. 89.—Semet-Solvay Coke-oven.

for combustion are introduced into the horizontal flues alternately from opposite sides, and at the same time mixed with air pre-heated by regenerators located in the base of the oven. The illustration shows a section through a heating flue, including one of the regenerators (the other not being shown). The products of combustion pass out through one of the regenerators into the stack. The other regenerator (not shown) is used for preheating the air to 1200–1400° F. After a time the paths of the gases are reversed, air being passed through the regenerator heated by the products of combustion, and vice-versa. Between 10,000 and 11,000 cu. ft. of gas are obtained per ton of coal, likewise 20 to 25 lb. of ammonium sulphate, and 9 to 10 gal. of tar. About half the gas is used for heating the retort, and the balance elsewhere for heating or illuminating purposes.

Otto-Hoffman Coke-oven. This oven, as modified by Dr. F. Schneiwind, is illustrated in Fig. 90. The heating is effected by vertical flues on either side of retorts (1) which are separated by hollow walls divided into 10 combustion chambers

¹J. W. Cobb, *J. Soc. Chem. Ind.*, 36, 525, 1917.

(2), each containing 4 vertical flues (3). An air-chamber (4) runs lengthwise underneath the floor of each retort passing through the openings (6) into the combustion flues (2). The air is pre-heated to 1800° F. by a pair of regenerators (7) operating alternately, and passed through the flue (5) into the air chamber (4). The gas for combustion is introduced through the pipe (10) into the combustion chamber (2). The products of combustion pass into the horizontal flue (9), then downward through the flues (not shown) corresponding to (3), but on the other side of the oven, through the regenerator (7), and thence into the chimney (not

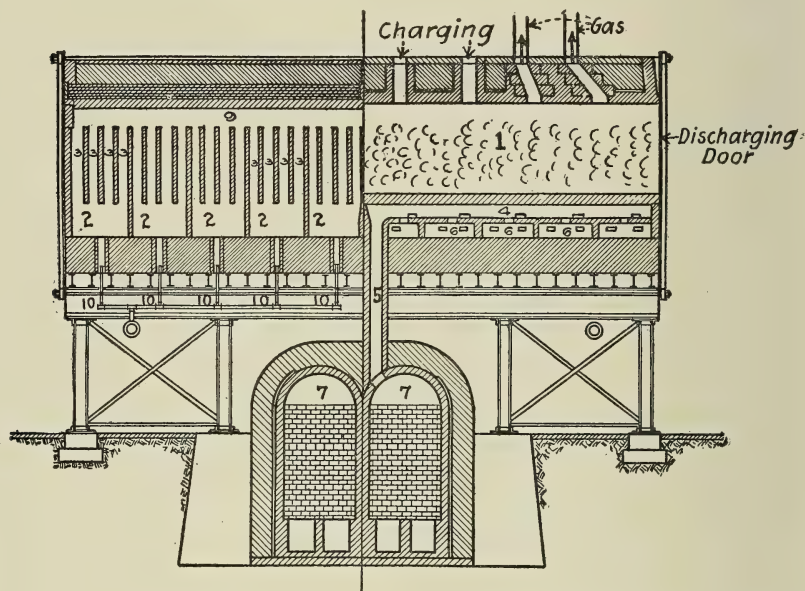

From "Coal and Coke," by F. H. Wagner.

Fig. 90.—Otto-Hoffman Coke-oven.

shown). When the temperature of the regenerator (7) used for pre-heating the air falls to 1300° F., the passage of gases is reversed.

The following yields per ton are recovered:

Gas.....	15.0-16.0% (8,500-10,500 cu. ft.)
Ammonium sulphate.....	0.8- 1.3%
Tar.....	3.0- 6.4%
Coke.....	70.0-75.0%

Approximately 20 per cent of the nitrogen present in the coal is converted into ammonium compounds, part of which is found in the tar as pyridine, quinoline, etc. About half of the nitrogen remains in the coke, and may be regarded as lost.

United-Otto Coke-oven. This is a modification of the Otto-Hoffman type, embodying the Hilgenstock principle of heating with vertical flues in conjunction with longitudinal regenerators (a) located underneath the retort (b), as illustrated in Fig. 91. The gas is introduced through one burner for each two vertical flues.

The heating is made uniform by operating the burners alternately in sets of four on opposite sides of the retorts. Thus gas is introduced into the first four burners on the right-hand side of the retort, the second four on the left, the third four on the right, and so on. The products of combustion pass out at the side opposite

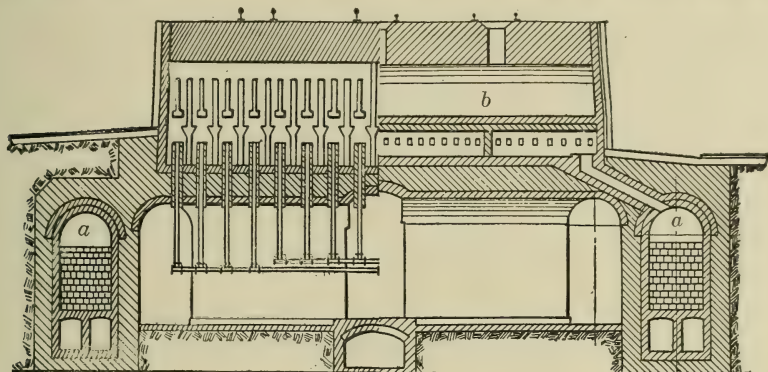

From "Coal and Coke" by F. H. Wagner.

FIG. 91.—United-Otto Coke-oven.

the burners, the respective paths being reversed from time to time. The yields from the United-Otto oven correspond very closely with those obtained from the Otto-Hoffman type.

Koppers Coke-oven. This oven is illustrated in Fig. 92, the left-hand portion representing a section through the heating flues, and the right, a section through the retort. The oven is heated by a set of vertical flues in the side walls, the

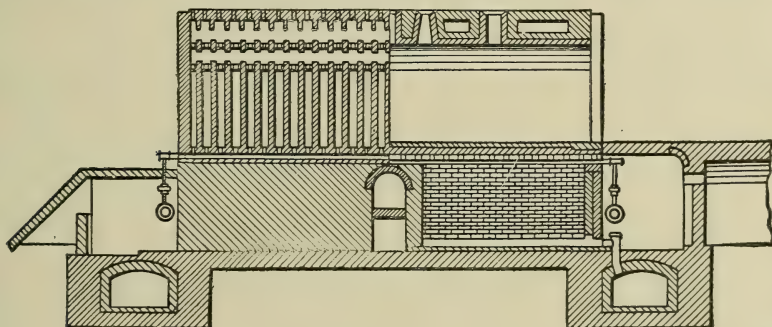

From "Coal and Coke," by F. H. Wagner.

FIG. 92.—Koppers Coke-oven.

heating gases and products of combustion respectively being passed through half the number alternately on each side and in opposite directions. The heating gas is admitted into a duct below the flues, and the air for combustion passes from the regenerator chambers directly into the vertical flues where it encounters the gas and undergoes combustion. The products of combustion travel upward in

one half of the oven and downwards in the other half, passing through the regenerators and thence into the chimney. Each oven is provided with two regenerators.

The average yield in per ton of coal is as follows:

Gas.....	11,000 cu. ft.
Ammonium sulphate.....	20 lb.
Tar.....	13.4 gal.
Coke.....	72%

Production of Blast-furnace Coal Tar. Most blast-furnaces in the United States employ coke as fuel and a few use anthracite coal. Since all the volatile constituents have been removed from coke, and as anthracite coal contains only a very small percentage, no tar is obtained when either of these is used for smelting ores in blast-furnaces. In such cases the gases evolved are subjected to a purification process merely to remove the entrained dust, before using them for heating purposes.

Owing to the scarcity of anthracite and the high cost of bituminous coal in Europe and Great Britain, there is a tendency to reduce the operating expenses by using the latter in its raw state, without first converting it into coke. A non-coking bituminous coal must be selected for this purpose. In such cases the gases emanating from the blast-furnace carry a certain amount of tar, derived from the volatile constituents of the coal, which must be removed before they can be used for heating or power purposes. The gases also carry a comparatively large amount of dust derived from the ores in the blast furnace, of which a good portion is removed by passing the hot gases through a device illustrated in Fig. 93, known as a "dry dust catcher." The gases entering the side of the catcher are given a rotary motion and their velocity reduced, whereupon they pass out at the top. This permits much of the dust to settle to the bottom, where it is emptied from time to time through a "spectacle valve."

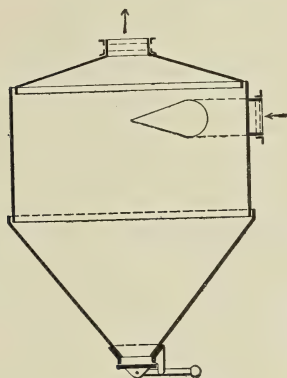

FIG. 93.—Blast-Furnace Dust Catcher.

Other, and more complicated forms of dry dust catchers are also used for the purpose, but all depend upon three factors, viz.:

- (1) Changing the direction of the gas current.
- (2) Impinging the gas against solid surfaces.
- (3) Reducing the velocity of the gases.

Methods of Recovering Blast-furnace Coal-Tar. After being dry-cleaned, the gases are subjected to a wet-cleaning and cooling process by passing them through any of the types of coolers, scrubbers, or washers described on pages 174-179. The centrifugal washer is usually preferred as it operates rapidly and economically. A part of the tar condenses in the coolers, and the balance in the scrubbers and washers. It carries a large quantity of the wash water, which may be separated by any of the means described on p. 180.

According to Lunge¹ approximately 7 gal. of blast-furnace tar and 29 lb. of ammonium sulphate are obtained from each ton of bituminous coal fed into the

¹"Coal Tar and Ammonia." New York, 1916.

blast-furnace. It appears that the iron ore and other minerals introduced with the coal influence the yield of tar. Thus the same bituminous coal gave the following weights of tar per ton under varying conditions:

Distilled alone in gas works.....	214 lb. of tar
Distilled with English iron ore.....	66 lb. of tar
Distilled with sand.....	170 lb. of tar

The tar derived from blast-furnaces always carries a substantial proportion of mineral matter, which the dust catchers fail to remove, and which serves to distinguish it from the other varieties of coal tar.

Production of Producer-gas Coal Tar. Unless the producer-gas plants are of a large capacity (above 4000 horse-power) it does not pay to recover the by-products. The smaller producers are designed to decompose the tar vapors and convert them into permanent gases, to avoid the expense of operating a tar-separating plant on one hand, or the trouble occasioned by the tar clogging the pipes and valves on the other. When anthracite coal or coke is used as fuel, no tarry vapors are produced.

From the standpoint of tar recovery, producers may be divided into three classes, viz.:

Type 1. Where the fuel travels in one direction, and the air and steam together in the opposite direction. This is usually accomplished by introducing the fuel at the top, and both the steam and air at the bottom of the producer.

Type 2. Where the fuel, air and steam all travel in the same direction. This may be accomplished by introducing all three either at the top, or at the bottom of the producer respectively.

Type 3. Where part of the air travels in the same direction as the fuel, and the balance of the air together with all the steam in the opposite direction. In this type the exit for the vapors is in the centre of the producer, the fuel and part of the air being introduced at the top, and the steam with the balance of the air at the bottom.

In all three types, four zones are distinguished, viz.:

(a) The ash zone, which represents the fuel after all the carbonaceous material has been consumed.

(b) The combustion zone, where the heat required for gasification is generated by the conversion of carbon into carbon dioxide. In this zone the highest temperature is attained (about 2100° F.).

(c) The decomposition zone, where the inter-action takes place between the steam and incandescent carbon, yielding hydrogen and carbon monoxide, and where the carbon dioxide generated into the combustion zone combines with incandescent carbon and is converted into carbon monoxide. In this zone the temperature is in the neighborhood of 1800° F., and all the carbon is consumed.

(d) The distillation zone, in which the raw fuel (e.g., the bituminous coal) undergoes partial distillation in consequence of the heat emanating from the decomposition zone (c).

In type 1 the ash zone is at the bottom, and the combustion, decomposition and distillation zones superimposed one above the other, in the order mentioned. Since the vapors are drawn off at the top it follows that the tar does not suffer decomposition.

In type 2 the distillation zone is at the top, the combustion zone directly beneath it, the decomposition zone still lower down, and the ash zone at the bottom of the producer. As the vapors are drawn from the bottom, the tarry matter generated in the distillation zone is forced through the entire column of incandescent fuel, and as a result is partly "cracked" into permanent gases, and partly burned into carbon dioxide which in turn is converted into carbon monoxide.

Type 3 is a combination of the other two, having two combustion zones, the upper part acting as a generator, and the lower as a producer. The distillation zone at the top is followed lower down by the first combustion zone, then the second combustion zone, and finally the ash zone at the bottom. The decomposition zone is in the centre, between the two combustion zones. In this type the tarry vapors evolved in the distillation zone are partly consumed by the incandescent fuel in the combustion zone directly beneath it. This producer is also used for treating fuels containing a large percentage of volatile matter, including peat and lignite (p. 172).

When ordinary bituminous coal is used as fuel, tarry matters are produced in Type 1, but not in Types 2 and 3, and the use of tar separators becomes superfluous in the two last named. When peat (p. 201), lignite (p. 209), pyrobituminous shales (p. 216), and certain "highly volatile" bituminous coals are used as fuel, tar is generated in all three types, but to the greatest extent in Type 1, and must accordingly be separated from the gases.

A representative Type 1 producer is illustrated in Fig. 94, known as a "suction gas producer," in which the vapors are drawn from the producer by means of a chimney or an exhaust fan, or else by the suction induced by the piston of a gas engine. The interior of the producer is maintained slightly below atmospheric pressure. It is constructed of double metal walls (*C* and *C'*) between which a current of air absorbs the heat radiated through the inner shell and enters the bottom of the producer through the pipe (*D*). The troughs (*E*) between the walls carry water, which is converted into steam by the heat and mixes with the air passing through. The bottom of the producer is filled with water (*G*) in which the ashes accumulate. The mixture of air and steam enters through the pipe (*H*), and the combustion zone is protected with a fire-brick lining (*B*). The charging hopper (*J*) is provided with a cover (*K*) and a counterweighted valve (*L*), constructed so that it is impossible to open either one, unless the other is closed. The gas is drawn from the producer through the pipe (*M*) and passed through the downcomer (*P*) leading into the scrubber (*N*). The producer and scrubber are connected with the purge pipe (*R*) by the water-sealed three-way valve (*O*) in such a manner that the scrubber cannot be in communication with the purge pipe. The scrubber removes the tar and cools the gases, which are used for heating or power purposes.

The tar is removed from the gases by one or more of the devices described on pp. 174-179. About 90 lb. of water-free tar and 90 lb. of ammonium sulphate are recovered per ton of bituminous coal. The tar as shipped, after being allowed to settle, often contains up to 20 per cent water.

Producers of Types 2 and 3 are illustrated in Figs. 95 and 96 respectively.

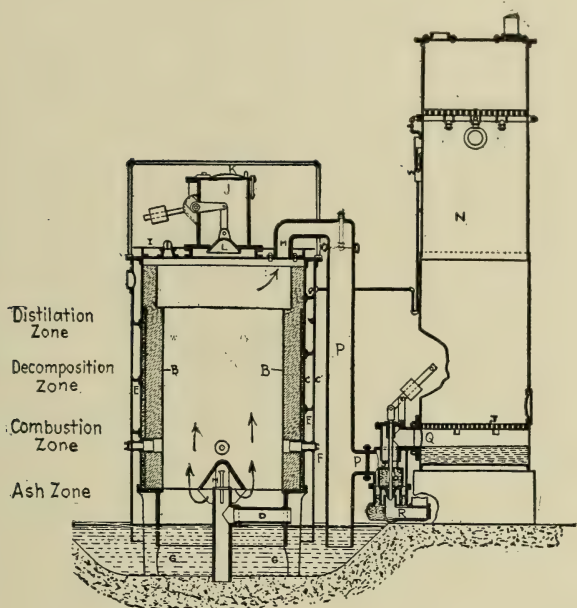

From "Gas Engines and Producers," by Marks.

FIG. 94.—Fairbanks-Morse Suction Gas-Producer, Type 1.

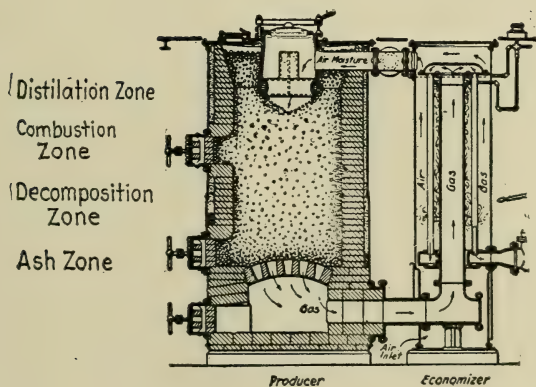

From "Gas Engines and Producers," by Marks.

FIG. 95.—Loomis-Pettibone Suction Gas-Producer, Type 2.

The Mond by-product gas producer is practically the only one used to any extent in the United States for recovering the tar and ammonium sulphate, which accounts for the fact that the former is not marketed in commercial quantities.

Properties of Coal Tars. As stated previously, the expression "coal tar" is properly applied to tars derived directly from coal without

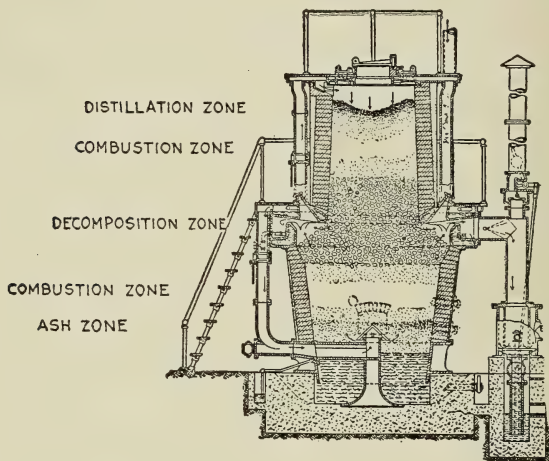

FIG. 96.—Westinghouse Gas-Producer, Type 3.

admixture of petroleum. Coal tars differ in their physical properties depending upon their method of production.¹ The following types are distinguished:

- (1) Gas-works coal tar
 - (a) From horizontal retorts
 - (b) From inclined retorts
 - (c) From vertical retorts
- (2) Coke-oven coal tar
- (3) Blast-furnace coal tar
- (4) Producer-gas coal tar

¹"Producer-gas Power-plant Development in Europe," by R. H. Fernald, Bulletin No. 4, Bureau of Mines, Wash., D. C., 1911. "Coal Gas Residuals," by F. H. Wagner, First Edition, New York, 1914. "Cleaning of Blast-furnace Gases," by F. H. Wagner, First Edition, New York, 1914. "Coal Tar Distillation," by Arthur R. Warnes, London, 1914. "American Coking Practice Up-to-date," by C. S. Lomax, *Gas World*, 63, 1620, 1915. "Gas Engines and Producers," by L. S. Marks and H. S. McDewell, Chicago, 1916. "Modern Gas Works Practice," by Alwyne Meade and Stanley H. Jones, London, 1916. "Coal and Coke," by F. H. Wagner, First Edition, New York, 1916. "Blast-furnace Construction in America," by J. E. Johnson, Jr., London, 1917; "Operation of Gas Works," by W. M. Russell, First Edition, New York, 1917.

The following figures will give a general idea of the physical properties of the four main classes of coal tar in their dehydrated state:

	Gas-works Coal Tar.	Coke-oven Coal Tar.	Blast-furnace Coal Tar.	Producer-gas Coal Tar.
(Test 1) Color in mass.....	Black	Black	Black	Black
(Test 2a) Homogeneity to the eye at room temperature .	Fine particles	Fine particles	Fine particles	Fine particles
(Test 2b) Homogeneity under the microscope.....	Lumpy	Lumpy	Lumpy	Lumpy
(Test 7) Sp.gr. at 77° F.....	1.15-1.30	1.10-1.30	1.15-1.30	1.15-1.30
(Test 8) Viscosity.....	Variable	Low	Low	Low
(Test 13) Odor.....	Characteristic	Characteristic	Characteristic	Characteristic
(Test 15) Fusing-point.....	Below 25° F.	Below 25° F.	Below 25° F.	Below 25° F.
(Test 16a) Volatile matter.....	25-50%	30-60%	30-60%	30-60%
(Test 17a) Flash-point.....	Low	Low	Low	Low
(Test 19) Fixed carbon.....	15-40%	15-40%	5-25%	10-35%
(Test 20) Distillation test (de- hydrated tar):				
Light oils (up to 235° C.).....	2-3½%	½-3½%
Middle, heavy and anthracene oils (235-355° C.).....	15-30%	20-35%
Soft pitch and loss (above 355° C.)..	60-85%	55-75%
(Test 21a) Soluble in carbon di- sulphide.....	60-95%	80-97%	65-80%	75-90%
(Test 21b) Non-mineral matter in- soluble (free carbon).	5-40%	3-20%	10-25%	10-25%
(Test 21c) Mineral matter.....	0-1%	0-1%	10-15%	0-2%
(Test 22) Carbenes.....	0-2%	0-2%	0-2%	0-2%
(Test 23) Solubility in 88° naphtha	20-40%	20-40%	15-35%	20-40%
(Test 25) Water.....	Trace	Trace	Trace	Trace
(Test 26) Carbon.....	88 -93%			
(Test 27) Hydrogen.....	4 -7%			
(Test 28) Sulphur.....	0.1-0.9%			
(Test 29) Nitrogen.....	1.0-1.5%			
(Test 30) Oxygen.....	1.0-3.0%			
(Test 31) Free carbon.....	(See Test 21b)			
(Test 32) Naphthalene.....	3 -10%			
(Test 33) Paraffine.....	0%			
(Test 35) Sulphonation residue..	0-5%	0-5%	5-20%	0-5%
(Test 37) Saponifiable.....	2-5%	2-5%	2-5%	2-5%
(Test 41) Diazo reaction.....	Yes	Yes	Yes	Yes
(Test 42) Anthraquinone reaction	Yes	Yes	Yes	Yes

J. M. Weiss furnishes the following figures representative of typical coal tars.¹

	GAS-WORKS COAL TAR.			COKE-OVEN COAL TAR.		
	Horizontal Retorts.	Inclined Retorts.	Vertical Retorts.	United Otto.	Semet-Solvay.	Koppers.
(Test 7) Specific gravity at 60° F.	1.266	1.238	1.153	1.207	1.188	1.186
(Test 8a) Specific Engler viscosity at 212° F.	21.8	14.9	2.1	3.4	3.0	2.1
(Test 20a) Distillation test (dehydrated tar):						
Distillate by volume to soft pitch of 60° C. fusing-point (cube method)	13.2%	14.3%	28.8%	21.2%	21.8%	35.3%
Residue by volume (soft pitch of 60° C. fusing-point—cube method)	86.8%	85.7%	71.2%	78.8%	78.2%	64.7%
Refraction index of distillate at 60° C.	1.5932	1.5807	1.5755	1.5987	1.6122	1.6139
(Test 31) Free carbon (insoluble in benzol)	28.9%	14.9%	2.1%	3.4%	3.0%	2.1%
(Test 35) Sulphonation residue	0.4%	2.4%	4.3%	0.0%	0.0%	0.0%
(Test 37e) Tar acids in above distillate	14.0%	21.0%	29.0%	12.0%	4.0%	0.0%

Weiss reports² that gas-works coal tar has a coefficient of expansion for 1° F. (length = 1) of 0.00027–0.00032 and coke-oven coal tar 0.00030–0.00034.

Weiss³ also reports the following relationship between the specific gravity and the free carbon in gas-house and coke-oven coal tars respectively.

	Specific Gravity at 60° F.	Free Carbon per cent.
Gas-house coal tar.	1.203–1.296	16.67–33.17
Coke-oven coal tar.	1.178–1.258	4.04–19.06

The differences between the tars produced at the present time may be roughly expressed as follows (W. H. Childs, loc. cit.): the gas-works coal tar derived from the old-fashioned horizontal retort is the heaviest, most viscous, containing a lower percentage of oils, the most pitch, and also the highest percentage of free carbon. Coke-oven coal tar occupies an intermediate position, being lighter, containing more oils, less pitch and less free carbon than the preceding. Gas-works coal tar derived from vertical retorts is lighter, less viscous, contains more oils, less pitch

¹ *J. Ind. Eng. Chem.*, **8**, 842, 1916.

² *J. Franklin Inst.*, **172**, 277, 1911.

³ *Ibid.*

and less free carbon than coke-oven coal tar. The following table contains the analyses of tars derived from gas-works and coke-ovens:

	GAS-WORKS COAL TARS.				COKE-OVEN COAL TARS.		
	Horizontal Retorts (old).	Horizontal Retorts (new).	Inclined Retorts.	Vertical Retorts.	Type A.	Type B.	Type C.
(Test 7) Specific gravity at 60° F.	1.254	1.218	1.198	1.154	1.178	1.173	1.187
(Test 8a) Engler viscosity at 212° F. (seconds for 100 c.c.)	273	103	89	30	76	30	37
(Test 20a) Distillation test (dehydrated tar):							
Light oil (to 400° F.	2.0%	3.3%	4.1%	3.7%	5.3%	1.8%	1.4%
Middle and creosote oils.	18.7%	21.1%	22.1%	30.2%	20.8%	35.0%	24.0%
Soft pitch (including loss)	79.3%	75.6%	73.8%	61.2%	73.9%	63.2%	74.6%
(Test 25) Water	2.8%	5.2%	3.3%	3.6%	1.0%	1.3%	2.3%
(Test 31) Free carbon (insoluble in benzol)	29.8%	21.6%	19.9%	3.7%	7.6%	4.3%	10.4%
(Test 37e) Tar acids (phenols, cresols, etc)	1.6%	2.9%	5.2%	7.2%	5.0%	1.1%	0.34

Coal tars may be recognized by the odor which is characteristic, by their high specific gravity, large percentage of free carbon (non-mineral matter insoluble in carbon disulphide), absence of paraffine, small percentage of sulphonation residue, small percentage of sulphur (0.10–0.90) and by the presence of phenols (diazo reaction), anthracene (anthraquinone reaction) and naphthalene.¹

Refining of Coal Tar.² Table XIX shows the approximate composition of coal tar and the various products derived therefrom.

According to G. Krämer,³ an average sample of European coal tar contained the following:

Benzol and its homologues	2.50%
Phenol and its homologues	2.00%
Pyridine and quinoline bases	0.25%
Naphthalene and acenaphthene	6.00%
Heavy oil	20.00%
Anthracene and phenanthrene	2.00%
Pitch	62.00%
Ammoniacal liquor	4.00%
Gases and loss	1.25%
Total	100.00%

¹ "Naphthalene in Road Tars," by Hubbard and Draper, Circular No. 96, Office of Public Roads, U. S. Dept. of Agri., Wash. D. C., Nov., 1911.

² "Coal Tar Light Oil in the United States; the Manufacture, Nature, and Uses of Products Derived Therefrom," by J. M. Weiss, 8th Intern. Cong. Applied Chem. **10**, 287, 1912; "Coal-tar Products," by Horace C. Porter and C. G. Storm, Circular 89, Bureau of Mines, Dept. of Interior, Wash., D. C., 1916; "Tar and Its By-products," by S. R. Church, *Gas Age*, **31**, 497, 1913; "Tar Distillation in the United States, General Development and Recent Progress," by R. P. Perry, 8th Intern. Cong. Applied Chem., **10**, 233, 1912, also *J. Ind. Eng. Chem.*, **5**, 151, 1913.

³ *J. Gasbel.* **34**, 225, 1891.

Coal tar is transported from the gas-works or coke-ovens in cylindrical steel tank-cars 7 to 8 ft. in diameter and 28 to 30 ft. long holding about 10,000 gal., provided with a dome on top and heating coils inside for the introduction of steam in cold weather to reduce the fluidity. It is transported by water in tank-vessels constructed similarly to those used for petroleum, holding up to 300,000 gal. At the distilling plant the tar is generally stored in covered vertical cylindrical steel tanks larger in diameter than height, having a capacity up to 2 million gallons. A certain amount of water separates out during storage which is tapped through pet-cocks in the side. Less often the tar is stored in rectangular reinforced concrete tanks built underground.

A preliminary insight may be obtained regarding the constitution and probable value of coal tar by subjecting it to a laboratory distillation test (see test 20, p. 521), according to which it is separated into five fractions and a residue of pitch. These fractions are distinguished as follows:

	<i>American Practice.</i>	<i>European Practice.</i>
Water, etc.....	Up to 110° C.	Up to 110° C.
Light oil.....	110-170° C.	110-170° C.
Middle oil.....	170-235° C.	170-230° C.
Heavy oil	235-355° C.	{ 230-270° C. { 270-350° C.
Anthracene oil. }		
Residue (coal-tar pitch).....	Above 355° C.	Above 350° C.

This test is often used by the stillman as a basis for arriving at the volume of the respective fractions to be separated in the works distillation.

The crude tar is first dehydrated by one of the methods described on p. 180. The method generally used in the United States consists in heating the tar in thin layers under partial vacuum. The tar is allowed to flow continuously over heated steam plates in a closed cylindrical vessel as described in method 5, p. 182, and which reduces the water to less than 0.5 per cent. From the dehydrator, the hot tar is pumped directly into the still.

The form of still used in the United States consists of a horizontal cylinder with convex ends heated directly either by coal or gas, constructed to hold as much as 75 tons of tar. A typical still is illustrated in Fig. 97. The tar enters through a pipe into the top of the still, and the vapors are drawn off through another pipe of large diameter attached directly to the top of the still, at the centre. The stills are not usually provided with domes as is the case with petroleum stills. The outlet pipe for the pitch is located at the bottom, together with inlet pipes for steam or air agitation. Sometimes vacuum is used to reduce the time of distillation. The stills are mounted on a brick

RODVC'

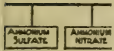

DDLE OIL

CRUDE NAPHTHAL

REFINED NAPHTHA

PHTHALIC AC

PHALENS

PHTHALIND

TESTUFS

AMPHALENS

INDIGO

MOL

YES

TOLUIDIN

DYESTUFS

META-CRESOL

OXID

NITRO-CESEL

EXPLOSIVES

TABLE XIX
 DIAGRAM OF THE PRODUCTS DERIVED FROM COAL AND SOME OF THEIR USES

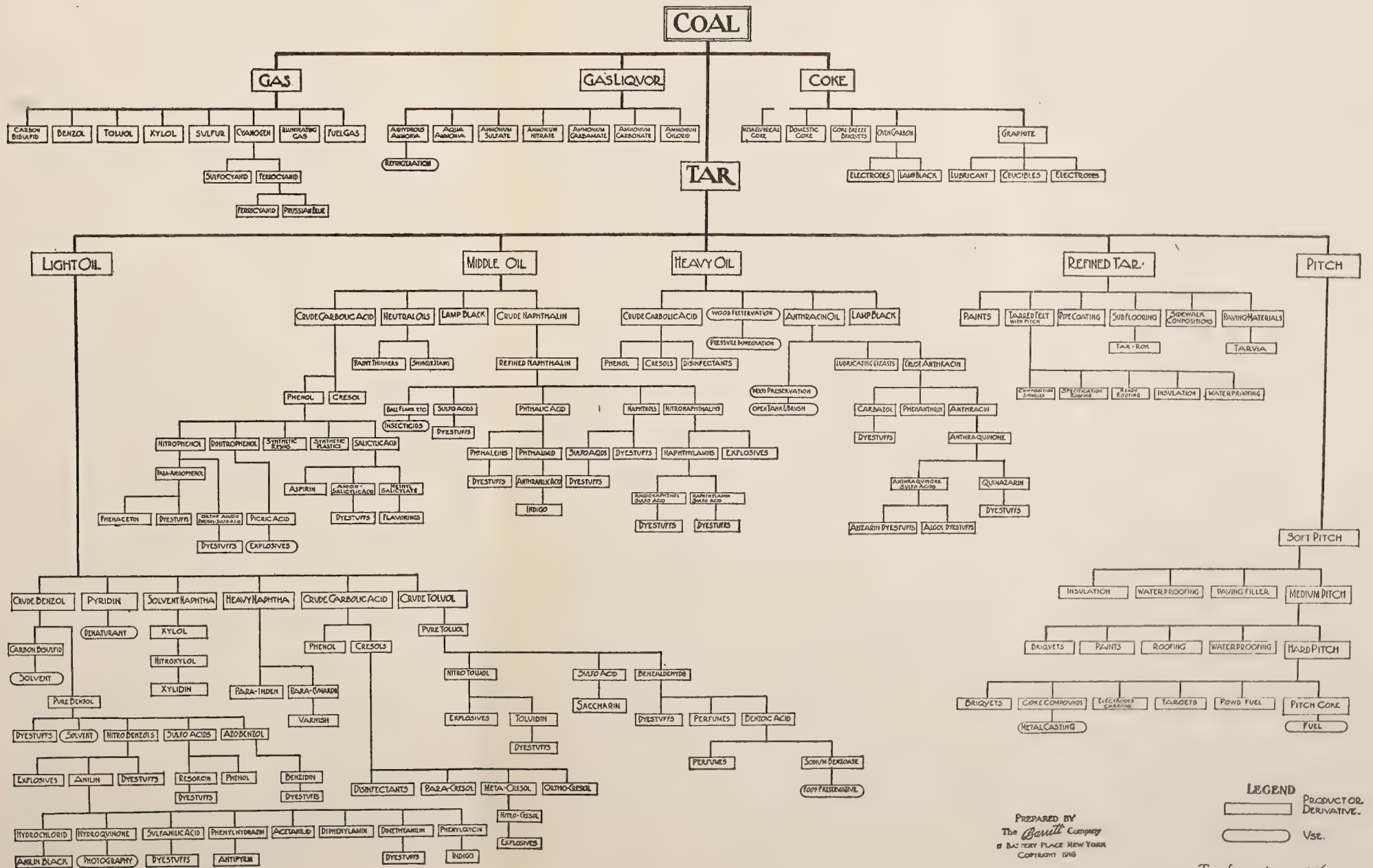

LEGEND
 [RECTANGLE] PRODUCT OR DERIVATIVE.
 [OVAL] USE.

PREPARED BY
 The Benitt Company
 21 BATTERY PLACE, NEW YORK
 COPYRIGHT 1918

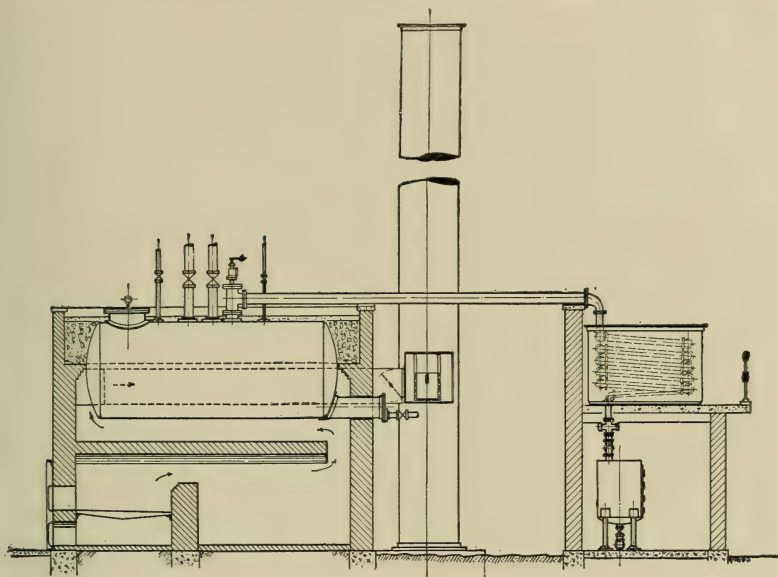

Courtesy of The Barrett Company.

FIG. 97.—Horizontal Still for Refining Coal Tar.

setting provided with a fire arch to insure uniform heating, and prolong the life of the bottom. The process is an intermittent one. After the tar has been distilled to the desired fusing-point or consistency the residue of pitch is discharged by gravity, pumping or blowing out with air.

In Europe, tar stills are constructed in the form of a "pot" or vertical still having a concave bottom, as illustrated in Fig. 98, where 1 represents the manhole; 2, safety-valve connection; 3, swan neck; 4, swan neck stool; 5, dipping tap; 6, steam inlet; 7, steam pipe; 8, tar inlet; 11, tar outlet. The concave bottom is claimed to have the advantages of providing a larger heating surface, also to assist in draining off the pitch and to accommodate the expansion and contrac-

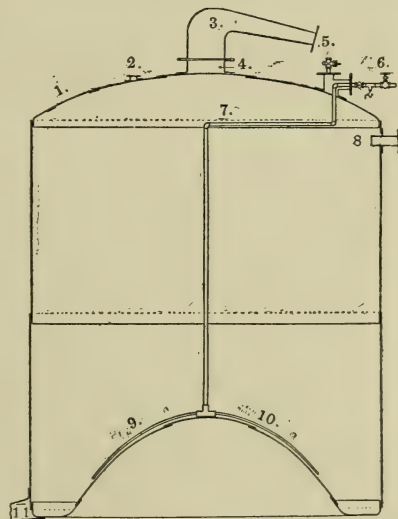

From "Coal Tar Distillation," by A. R. Warnes.

FIG. 98.—Vertical Still for Refining Coal Tar.

tion of the metal plates without setting up dangerous strains. Steam is introduced during the process of distillation through a perforated pipe (9-10) at the bottom and serves to carry off the vapors more rapidly, also reduce the time of distillation. English stills hold 20 to 40 tons of tar, and are mounted on suitable brick settings adapted for direct heating with coal or producer gas.

The vapors leave the still through a large pipe connected with the condenser coils immersed in water in a rectangular tank. These coils are constructed of pipes ranging from 6 in. down to 3 in. in diameter. The distillate is run into small measuring tanks which in turn empty into large storage tanks. Each fraction is caught separately, four fractions all told being recovered, viz.: light oil or crude naphtha, middle or carbolic oil, heavy or creosote oil and anthracene oil.

On starting the distillation, the light oil or crude naphtha boils over, comprising the entire distillate lighter than water. When the vapor temperature reaches about 200° C. the receiver is changed, and the next runnings constituting the middle or carbolic oil are caught separately. The light oil fraction varies from less than 1 per cent to 3 or 4 per cent. It is redistilled and fractioned into solvent naphtha and heavy naphtha, also small amounts of crude benzol, toluol, phenol and cresols.

The middle or carbolic oil comes over next, amounting to 5 to 15 per cent. As the temperature increases, naphthalene crystallizes out in the distillate, and to prevent it choking the condensing coils, the cooling water is shut off. It is cut at such a point to include most of the tar acids and naphthalene, and is cooled to remove the naphthalene and sold as a disinfectant. The tar acids may also be extracted with caustic soda and liberated by sulphuric acid or carbon dioxide. The phenol content of tar seldom exceeds $\frac{1}{4}$ per cent, and naphthalene recovered from this and the succeeding fractions will range from 5 to 7 per cent.

As the temperature increases, the heavy or dead or creosote oil boils over. This may represent the entire fraction between the middle oil and the end of the distillation, in which event it will constitute 15 to 35 per cent of the tar, or it may be cut sooner and the anthracene oil caught separately. In either event the distillation is assisted by introducing live steam. The distillate is cooled to remove any naphthalene, and the cresols extracted in the same manner as phenol. The anthracene oil is treated to separate pure anthracene, amounting to 0.2 per cent of the tar, which constitutes the source of alizarin used in manufacturing coal-tar dyes.

When the distillation is completed the pitch remains as a residue in the still, amounting to 50 to 80 per cent of the tar, and varying from a

viscous to a hard and brittle product, depending upon the quantity of distillate removed. It is allowed to run or pumped into a cooler consisting of a rectangular (8×8×8 ft.) or cylindrical vessel, and allowed to remain until the temperature falls to 250 to 300° F., whereupon it is run into barrels. Each still is provided with two or more coolers, so as not to delay removing the pitch.

The stillman is guided in separating the various fractions by the volumes recovered, calculated from the percentages reported by the laboratory distillation test.

Various types of stills adapted to the continuous distillation of tar, have recently attracted attention. Among them the Kubierschky system¹ is claimed to give good results. The tar is sprayed into the still, and at the same time a current of superheated steam introduced from below comes in direct contact with the tar. The distillation progresses in stages in a series of connecting chambers, from each of which a different fraction is recovered, the pitch residue being drawn off at the bottom. It is claimed that it is unnecessary to first dehydrate the tar, also that the steam consumption is comparatively small.

One of the most promising systems, from a scientific standpoint, for separating coal tar into its various fractions, was devised by Walther Feld,² by which the

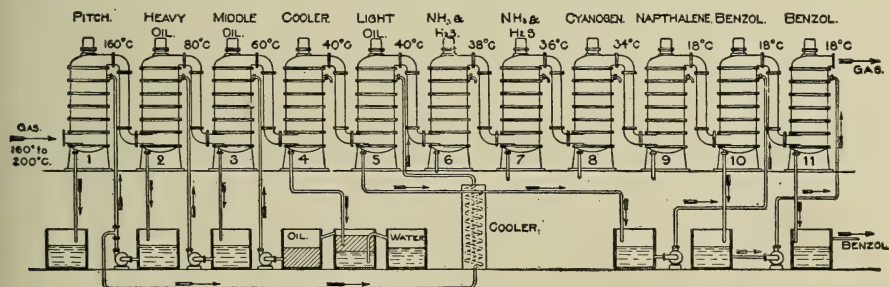

FIG. 99.—Feld System for Fractionating Coal Tar.

tar vapors are fractionated directly as they come from the gas-retorts or coke-ovens. The principle involved is exactly the reverse of the foregoing methods. In the Feld system, the hot tar vapors are separated into various fractions by a system of selective cooling, whereas in the other methods the coal tar is progressively heated to successively increasing temperature and each fraction condensed as it vaporizes. One of the main advantages claimed for the Feld system is the saving of fuel, since it utilizes the heat extant in the hot tar vapors and obviates reheating.

A rough outline of the Feld condensing system is illustrated in Fig. 99. The hot vapors coming from the retorts of ovens are passed through a series of Feld centrifugal scrubbers (see p. 177) in each one of which the washing liquid constitutes

¹ *J. Gas Lighting*, 130, 448, 1915.

² "Coal Gas Residuals," by F. H. Wagner. N. Y. 1914.

a portion of the condensate recovered in the next succeeding washer, and has therefore, a lower boiling-point than the fraction to be separated. Altogether 11 centrifugal washers are proposed. The vapors coming from the hydraulic main at a temperature of 200° C. are introduced into washer No. 1, and washed with a carefully regulated quantity of "heavy oils" obtained from washer No. 2 (previously brought to a temperature of 160° C.) to reduce the temperature of the vapors in washer No. 1 to 160° C. This effects a separation of the constituents boiling above 320-350° C. (i.e., the pitch) from those of lower boiling-points ("dew points"). The reduction in temperature of the hot vapors may be accounted for partly by the low temperature of the circulating liquid and partly because of its vaporization and consequent absorption of heat.

The vapors now at a temperature of 160° C. are passed into washer No. 2, through which sufficient "middle oils" obtained from washer No. 3 (at a temperature of 80° C.) are circulated to reduce the temperature of the vapors in washer No. 2 to 80° C., and thus bring about a condensation of the constituents boiling between 230 and 320° C., known as the "heavy oils."

Similarly, washer No. 3 removes the middle oils by circulating a quantity of the oil condensed in washer No. 4 (at a temperature of 60° C.), which serves to reduce the temperature of the vapors to 60° C.

A detailed plan of operation is indicated in Table XX:

TABLE XX

Washer No.	Circulating Liquid.	Temp. of Circulating Liquid, Deg. C.	Temperature of Vapors Reduced, Deg. C.		Constituents Separated from the Vapors.	Boiling-Point of Condensate Deg. C.
			From	To		
1	Warmed heavy oils from No. 2.	160	200	160	Pitch.....	Above 320-350
2	Warmed middle oils from No. 3.	80	160	80	Heavy oil (anthracene oil).	230-320
3	Warmed oils from No. 4.	60	80	60	Middle oil (creosote oil)	170-230
4	Water.....	40	60	40	Oils and water
5	Cooled heavy oils from No. 2.	40	40		Light oil.....	Below 170
6	Water.....	38	40	38	Ammonia and hydrogen sulphide
7	Water.....	36	38	36	Ammonia and hydrogen sulphide
8	Water.....	34	36	34	Cyanogen
9	Water.....	18	34	18	Naphthalene
10	Cooled light oils from No. 5.	18	18		Benzol
11	Benzol from No. 10.....	18	18		Benzol

It is claimed that the vapors thus treated produce a gas of greater illuminating power than one which has been purified in the usual manner, also that the method is adapted equally well for treating gas-house or coke-oven products. It has also been used apparently with some success abroad for the fractional separation of the tarry vapors obtained on destructively distilling Bohemian lignite (browncoal) but has not come into use in this country. The yield of pitch from the Feld

process is lower than that obtained from the ordinary method, and the yield of the more valuable oils correspondingly increased. In one case a bituminous coal yielding 35 per cent of pitch by the ordinary method produced $7\frac{1}{2}$ to 12 per cent by the Feld process.

Properties of Coal-tar Pitches. The extent to which the distillation or condensation is continued in any of the foregoing methods determines the character and nature of the residue. If the light oil and part of the middle oil are distilled off, there remains a product varying in consistency from a thin to a more or less viscous liquid, known as "refined coal tar" or "distilled coal tar." Its physical properties are intermediate between the crude tars and the pitches. These tars are used for road binders (see p. 357) or for saturating purposes (see p. 395) Coal tar suitable for saturating roofing felt is usually prepared by distilling a charge until the residue tests between 80 and 120 at 40° F. by the Shutte penetrometer (test 8e). If the distillation is continued to the desired point, then the residue is known as "straight-run coal-tar pitch." On the other hand, if the distillation is carried to a point where the residue is harder and more infusible than desired, and is thereupon fluxed to the desired consistency and fusing-point either with certain fractions of the distillate or a flux of foreign origin—usually of little value commercially—or with other tars, then the pitch is known as "cut-back coal-tar pitch."

Prepared tar suitable for road treatment may be manufactured by selecting suitable crude or dehydrated tars, combining them in the still and running to the proper consistency. Another plan consists in running a single tar to pitch, adding a suitable quantity of dehydrated or distilled tar, and agitating with air introduced through a perforated pipe.

Coal-tar pitches have been arbitrarily classified as follows: "soft pitch," having a fusing-point between 90 and 120° F. (cube method) used principally for road binders and sometimes for waterproofing work (see p. 442); "medium pitch," having a fusing-point between 120 and 160° F. (cube method), used for constructing "pitch and felt roofs" (see p. 444), for waterproofing work (see p. 443), for filling joints in stone pavements (see p. 382) and for manufacturing paints (see p. 462); "hard pitch," having a fusing-point between 160 and 210° F. (cube method), used principally for briquetting purposes (see p. 454); "very hard pitch" having a fusing-point above 210° F. and rarely exceeding 266° F.,¹ used as binders for sand cores in forming castings of iron and steel, also for manufacturing electric light carbons, battery carbons, plastic compositions for insulating purposes and black "clay pigeons" for target shooting.

¹ It is possible to prepare coal-tar pitches fusing as high as 345° F., but these are scarcely ever encountered.

J. M. Weiss reports¹ that the specific gravity of coal-tar pitch varies from 1.200–1.290 at a fusing-point of 100° F. (cube method) to 1.250–1.350 at a fusing-point of 190–200° F. (cube method).

Coal-tar pitches show the following ranges:

	Gas-works Coal-tar Pitch.	Coke-oven Coal-tar Pitch.	Blast-furnace Coal-tar Pitch.	Producer-gas Coal-tar Pitch.
(Test 1) Color in mass.....	Black	Black	Black	Black
(Test 2a) Homogeneity at 77° F.....	Variable	Variable	Variable	Variable
(Test 2a) Homogeneity under microscope.	Carbon visible	Carbon visible	Carbon visible	Carbon visible
(Test 2b) Homogeneity when melted.....	Uniform	Uniform	Uniform	Uniform
(Test 3) Appearance surface on aging ..	Unchanged	Unchanged	Unchanged	Unchanged
(Test 4) Fracture.....	Conchoidal	Conchoidal	Conchoidal	Conchoidal
(Test 5) Lustre.....	Variable	Variable	Variable	Variable
(Test 6) Streak.....	Black	Black	Black	Black
(Test 7) Sp. gr. at 77° F.....	1.15–1.40	1.20–1.35	1.20–1.30	1.20–1.35
(Test 9c) Hardness at 77° F.....	10–100	10–100	10–100	10–100
(Test 9d) Susceptibility factor.....	>100	>100	>100	>100
(Test 10b) Ductility at 77° F.....	Variable	Variable	Variable	Variable
(Test 13) Odor on heating.....	Penetrating odor characteristic of all coal-tar pitches.			
(Test 14a) Behavior on heating.....	Passes rapidly from the solid into the liquid state.			
(Test 15a) Fusing-point (K. and S. method)	80–300° F.	80–300° F.	80–300° F.	80–300° F.
(Test 15b) Fusing-point (Cube method)....	90–345° F.	90–345° F.	90–345° F.	90–345° F.
(Test 16) Volatile matter, 500° F., 4 hrs..	3–20%	3–20%	3–20%	3–20%
(Test 17a) Flash-point.....	250–450° F.	250–450° F.	250–450° F.	250–450° F.
(Test 18) Burning-point.....	300–500° F.	300–500° F.	300–500° F.	300–500° F.
(Test 19) Fixed carbon.....	30–45%	20–45%	10–30%	20–45%
(Test 21a) Soluble in carbon disulphide....	55–90%	60–85%	50–75%	60–85%
(Test 21b) Non-mineral matter insoluble....	10–45%	15–40%	15–35%	15–40%
(Test 21c) Mineral matter.....	0–1%	0–1%	10–20%	0–2%
(Test 22) Carbenes.....	2–10%	2–10%	2–10%	2–10%
(Test 23) Soluble in 88° naphtha.....	10–30%	10–30%	5–25%	10–30%
(Test 24) Soluble in other solvents.....	Coal-tar pitches are largely soluble in carbon disulphide, benzol, coal-tar distillates, carbon tetrachloride, chloroform, and glacial acetic acid. They are only partly soluble in petroleum distillates, turpentine, grain or wood alcohol.			
(Test 26) Carbon*.....	90–95%			
(Test 27) Hydrogen.....	3–5%			
(Test 28) Sulphur.....	0.5–1.0%			
(Test 29) Nitrogen.....	0.2–1.2%			
(Test 30) Oxygen.....	Trace–2.0%			
(Test 32) Naphthalene.....	Trace–2.5%			
(Test 33) Paraffine.....	0.0%			
(Test 35) Sulphonation residue.....	0–5%	0–5%	5–20%	0–5%
(Test 37) Saponifiable constituents.....	Tr.–1%	Tr.–1%	Tr.–1%	Tr.–1%
(Test 40) Glycerol.....				
(Test 41) Diazo reaction.....	0.0%			
(Test 42) Anthraquinone reaction.....	Yes			

* For the ultimate analysis of coal-tar pitches, refer to Donath and Asriel, *Chem. Rev. Fett-Harz-Ind.*, **10**, 54, 1903; also C. R. Downs, *J. Ind. Eng. Chem.*, **6**, 206, 1914.

¹ *J. Ind. Eng. Chem.*, **8**, 841, 1916.

Church and Weiss examined representative specimens of coal-tar pitches,¹ with the following results, in which *A* represents gas-works coal-tar pitch obtained from horizontal retorts, *B* gas-works coal-tar pitch from inclined retorts, *C* gas-works coal-tar pitch from vertical retorts, *D* Otto-Hoffman coke-oven coal-tar pitch, *E* Semet-Solvey coke-oven coal-tar pitch, and *F* Scotch blast-furnace coal-tar pitch:

	<i>A</i>	<i>B</i>	<i>C</i>	<i>D</i>	<i>E</i>	<i>F</i>
(Test 7) Sp. gr. at 60° F.	1.30	1.28	1.19	1.25	1.25	1.23
(Test 9b) Hardness at 115° F. (50 g. for 5 s.)	Too soft	Too soft	Too soft	Too soft	Too soft	324
Hardness at 77° F. (100 g. for 5 s.)	39	40	44	41	39	41
Hardness at 32° F. (200 g. for 60 s.)	2	2	2	3	2	8
(Test 15c) Fusing-point (cube method)	125° F.	123° F.	125° F.	126° F.	126° F.	135° F.
(Test 19) Fixed carbon	41.5%	37.0%	16.3%	28.5%	28.2%	14.4%
(Test 21a) Sol. in carbon disulphide	64.9%	67.8%	89.5%	79.9%	82.5%	58.2%
(Test 21b) Non-mineral matter insoluble	34.9%	32.0%	10.3%	19.7%	17.4%	30.0%
(Test 21c) Mineral matter	0.2%	0.2%	0.2%	0.4%	0.1%	11.8%
(Test 22) Carbenes	3.5%	2.8%	5.3%	7.4%	5.9%	2.6%
(Test 31) Insoluble in benzol and toluol (free carbon) ...	34.9%	30.8%	8.0%	21.1%	18.3%	28.4%

A sample representing a well-advertised brand of straight-run gas-works coal-tar pitch was tested by the author with the following results:

(Test 7) Specific gravity at 77° F.	1.25
(Test 9a) Consistency at 115° F.	5.0
Consistency at 77° F.	24.7
Consistency at 32° F.	> 150
(Test 9a) Susceptibility factor	> 100
(Test 10b) Ductility at 115° F.	35
Ductility at 77° F.	75.5
(Test 9a) Ductility at 32° F.	0
(Test 11) Tensile strength at 115° F.	0.15
Tensile strength at 77° F.	4.65
Tensile strength at 32° F.	8.5
(Test 15a) Fusing-point (K. and S. method)	122° F.
(Test 16) Volatile matter, 500° F. in 4 hrs.	8.2%
(Test 17a) Flash-point	360° F.

The consistency, tensile strength (multiplied by 10) and ductility curves are shown in Fig. 100.

Coal-tar pitches are characterized as follows:²

- (1) Jet black streak on porcelain.
- (2) Carbonaceous matter clearly visible under microscope.
- (3) Comparatively high specific gravity.

¹ *Proc. Am. Soc. Testing Materials*, **15**, 274, Part II, 1915.

² "Chemische Zusammensetzung und Untersuchung der natürlichen und künstlichen Asphalte," J. Marcussen, *Chem. Rev. Fett-Harz-Ind.*, **19**, 166, 1912; "Nachweis von Naturasphalt und Erdölpech in Rückständen der Steinkohlenteerdestillation," F. Schwartz, *Chem. Rev. Fett-Harz-Ind.*, **20**, 28, 1913.

(4) High susceptibility factor. This means that they are largely influenced by changes in temperature, becoming brittle in winter, and softening under extreme summer heat.

(5) High ductility when tested at temperatures ranging between the solid and fluid states.

(6) Characteristic odor on heating.

(7) Pass rapidly from the solid to the fluid state.

(8) Comparatively high percentage of volatile constituents when heated at 500° F. for 4 hours.

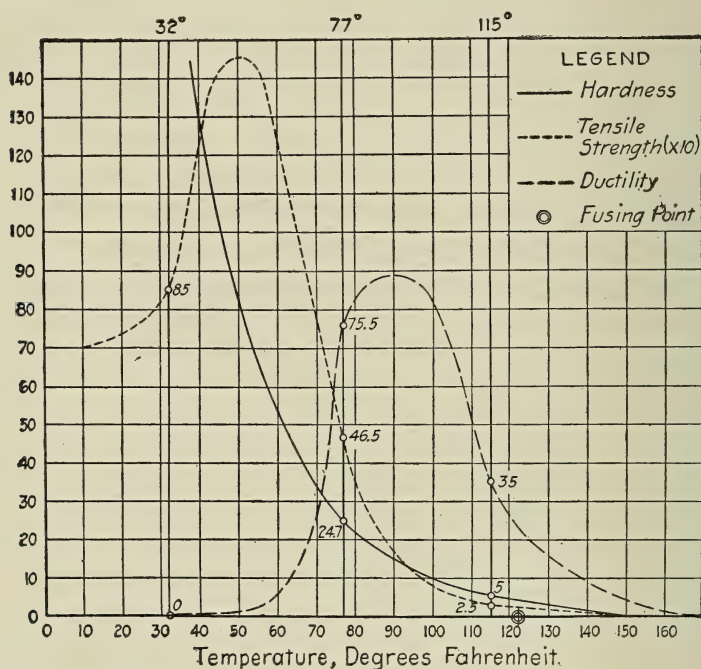

FIG. 100.—Chart of Physical Characteristics of Coal-tar Pitch.

(9) Comparatively high percentage of fixed carbon.

(10) Comparatively high percentage of non-mineral matter insoluble in carbon disulphide ("free carbon").

(11) Comparative insolubility in petroleum naphtha.

(12) Comparatively small percentage of sulphur.

(13) Presence of naphthalene.

(14) Absence of paraffine.

(15) Comparatively small percentage of sulphonation residue.

(16) Give both the diazo and anthraquinone reactions.

Coal-tar pitches are remarkably resistant to the disintegrative action of water, and are therefore well adapted for sub-soil waterproofing. They are more weather resistant than wood-tar pitch, rosin pitch, lignite-tar pitch, shale-tar pitch and bone-tar pitch, but are inferior to carefully prepared residual asphalts obtained from petroleum, blown petroleum asphalts, wurtzilite asphalt, fatty-acid pitches and pure native asphalts containing approximately the same percentage of volatile matter (see p. 341).

Attempts have been made to blow coal-tar pitches by the same process used for treating petroleum asphalts (p. 287). Samples tested by the author showed a slight lowering of specific gravity, a decrease in the hardness for a given fusing-point, a decrease in the susceptibility factor (i.e., the material was less affected by changes in temperature) and no appreciable change in the ductility. Blown coal-tar pitches have not been marketed in commercial quantities, nevertheless they warrant further development.

Specimens of blown coal-tar pitches examined by the writer showed the following results:

	A	B	C
(Test 7) Specific gravity at 77° F.....	1.184	1.194	1.202
(Test 9c) Consistency at 115° F.....	1.08	4.31	5.94
Consistency at 77° F.....	10.0	57.5	66.9
Consistency at 32° F.....	> 100	> 100	> 100
(Test 9d) Susceptibility factor.....	> 89	> 70	> 66
(Test 10b) Ductility at 115° F.....	51	100	92
Ductility at 77° F.....	100	0.25	0.0
Ductility at 32° F.....	0.0	0.0	0.0
(Test 11) Tensile strength at 115° F.....	0.1	0.9	1.4
Tensile strength at 77° F.....	2.1	8.0	8.8
Tensile strength at 32° F.....	5.5	6.5	7.5
(Test 15a) Fusing-point (K. and S. method).....	112° F.	136° F.	141° F.

CHAPTER XVIII

WATER-GAS AND OIL-GAS TARS AND PITCHES

WATER-GAS tar, oil-gas tar and their corresponding pitches are not classified with "coal tar" and "coal-tar pitch," as they are intermediate in their properties between the latter and petroleum asphalts on account of the petroleum products used in their manufacture. They are accordingly included in a separate chapter.

Water-gas Tar. The mechanism of this process has already been briefly described on page 173. A modern water-gas plant having a capacity of $1\frac{1}{2}$ to 3 million cubic feet of gas per day is illustrated in Fig. 101. This

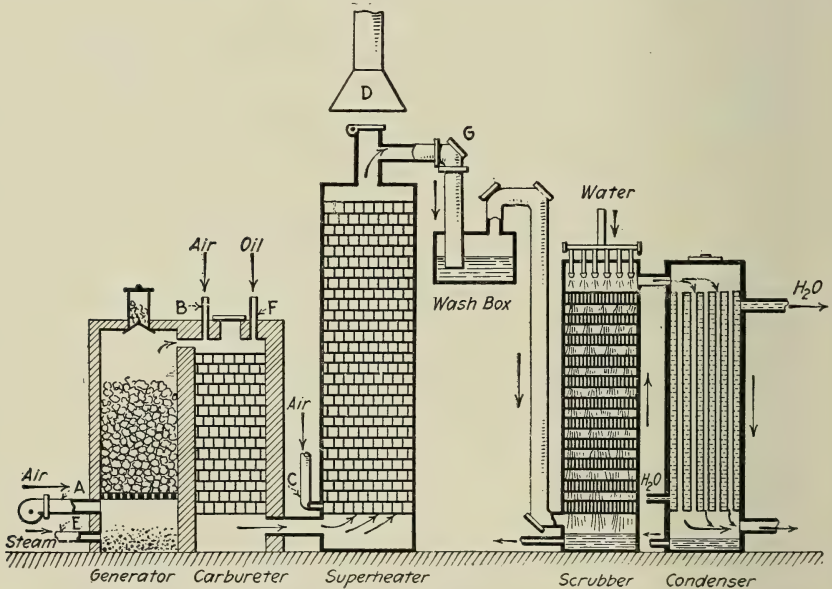

FIG. 101.—Lowe Water-gas Plant.

is known as the Lowe type of apparatus. Either anthracite coal or coke may be used as fuel. The former should preferably show less than 7 per cent volatile on ignition, not more than 12 per cent ash having a high fusing point to avoid "clinking," also small percentages of moisture and sulphur.

The fuel is charged into the generator and allowed to undergo partial combustion by admitting a limited amount of primary air through the pipe *A* below the bed of fuel. The gases then pass downward through the carbureter and the combustion almost completed by means of a carefully regulated supply of secondary air introduced through the valve *B*. From the carbureter the products pass upward through the superheater, where the temperature may be controlled by admitting a tertiary supply of air through the valve *C*, and the products of combustion finally passed into the atmosphere through the stack *D*.

When the fuel in the gas-generator has been properly ignited, and the carbureter and superheater brought to the required temperatures, the air blasts are cut off in the sequence: *C*, *B*, and *A*, and the stack valve *D* closed. Steam is introduced into the generator through the valve *E* below the bed of incandescent fuel and results in the production of "blue-gas," according to the following reaction: $C + H_2O = CO + H_2$. This is passed into the carbureter where it mingles with a spray of carbureting oil known as "gas oil" introduced through *F*. The mixture is passed downward through the carbureter whereby the oil becomes vaporized. From the carbureter, the gases are passed up through the superheater, the temperature of which is very carefully regulated at 1200–1300° F. to crack the oil vapors into permanent gases, and this incidentally results in the formation of tarry matters.

The formation of carbon monoxide and hydrogen by the action of steam on incandescent fuel results in a lowering of the temperature on account of the absorption or storing up of thermal energy, so that it becomes necessary to turn off the steam and reintroduce the air. The "blowing up" process is thus repeated. At the same time the oil spray is turned off the carbureter, as its temperature has fallen to a point below which the oil would not be superheated sufficiently to convert it into a permanent gas.

The supplies of air, steam and oil are carefully metered and the temperatures controlled by electric pyrometers within 20 to 40° C. The "blowing" or "up run" lasts three to five minutes, and the "gas making" or "down run" lasts two to four minutes.

The water-gas and accompanying tarry vapors derived from the gas oil are passed from the superheater through the pipe *G* into a wash-box which corresponds to the hydraulic main in a coal-gas plant. The vaporization of water in the wash-box reduces the temperature of the gases from 1200 to 190° F. The gases next pass upward through a scrubber filled with shelves carrying a checker-work of wooden slats (Fig. 63) over which water is allowed to trickle. From the scrubber the vapors are passed

downward through a water-cooled condenser (Fig. 60) which reduces their temperature to 140–150° F., and thence into a relief gas-holder. Most of the tar is condensed in the wash-box and smaller quantities in the scrubber and condenser. An exhauster draws the gases through the foregoing train of apparatus and then forces them through a tar extractor, usually of the P. & A. type (Fig. 69), to remove the last traces of tar. The temperature of the gases as they pass through the tar extractor is in the neighborhood of 110 to 115° F. They are finally passed through the purifier filled with trays of ferric oxide to remove the sulphur compounds, and thence into the main gas holder.

The carbureting oil, known also as "gas oil" or "enriching oil" varies in composition depending upon the character of the petroleum from which it is derived. Experience demonstrates that oils obtained from a paraffine base petroleum generate the greatest proportion of gas and the smallest quantity of tar. Oils containing unsaturated straight-chain hydrocarbons are less efficient, and those containing unsaturated ring hydrocarbons are almost valueless. The yield of tar expressed in percentage by volume, based on the various types of petroleum used, is as follows:

Paraffine base naphtha.....	2-4%
Paraffine base gas oil.....	6-10%
Paraffine base crude oil.....	8-12%
Asphaltic base gas oil.....	10-15%
Asphaltic base crude oil.....	12-18%

The effect of the temperature on the decomposition of an asphaltic petroleum is shown in the following table:

Temperature, Deg. C.	Cu. Ft. Gas per Gal. Oil.	Tar, Per Cent.	Coke, Per Cent.
711	56.4	28.0	1.83
741	61.5	29.4	2.43
751	63.7	26.2	3.63
789	68.0	24.2	3.45
832	80.3	11.9	12.43

The quantity of carbureting oil ordinarily used varies from 3.5 to 4.5 gal. per ton of anthracite coal.

Water-gas tar on account of its low specific gravity forms an emulsion with the associated water and separates with great difficulty. The water is practically free from ammonia compounds, thus differing from coal tar, and the tar is very much thinner in consistency, containing but a small amount of free carbon. The methods for dehydrating crude water-gas

tar have been described (pp. 180-183), and the dehydrated water-gas tar complies with the following tests:

(Test 1)	Color in mass.....	Black	
(Test 2a)	Homogeneity to the eye.....	Uniform	
(Test 2b)	Homogeneity under microscope.....	Absence of carbonaceous matter	
(Test 7)	Specific gravity at 77° F.....	1.05-1.15	
(Test 8)	Viscosity.....	Very liquid	
(Test 13)	Odor on heating.....	Characteristic "gas-like"	
(Test 15a)	Fusing-point (K. and S. method).....	Less than 0° to 10° F.	
(Test 16)	Volatile matter at 500° F., 4 hrs.....	60-85%	
(Test 17a)	Flash-point.....	Low	
(Test 19)	Fixed carbon.....	10-20%	
(Test 20)	Distillation:		
	Up to 110° C. (Naphtha).....	0 - 5% by weight	(Sp.gr. 0.85-0.90)
	110-170° C. (Light oils).....	0.5- 5.0%	(Sp.gr. 0.88-0.90)
	170-235° C. (Middle oils).....	5 -35%	(Sp.gr. 0.98-1.00)
	235-270° C. (Heavy oils).....	7 -30%	(Sp.gr. 1.00-1.07)
	270-350° C. (Anthracene oil).....	10 -25%	(Sp.gr. 1.07-1.10)
	Residue (Water-gas-tar pitch).....	20 -60%	
(Test 21a)	Solubility in carbon disulphide.....	98 -100%	
(Test 21b)	Non-mineral matter insoluble.....	0 - 2%	
(Test 21c)	Mineral matter.....	0 - 1%	
(Test 22)	Carbenes.....	0 - 2%	
(Test 23)	Solubility in 88° naphtha.....	20 - 75%	
(Test 26)	Carbon.....	90 - 95%	
(Test 27)	Hydrogen.....	3 - 6%	
(Test 28)	Sulphur.....	0.5- 2.0%	
(Test 29)	Nitrogen.....	0.5- 1.0%	
(Test 30)	Oxygen.....	1 -2%	
(Test 32)	Naphthalene.....	Less than 10%	
(Test 33)	Paraffine.....	0 -5%	
(Test 35)	Sulphonation residue.....	0 -15%	
(Test 37)	Saponifiable constituents.....	Tr. -2%	
(Test 41)	Diazo reaction.....	Yes	
(Test 42)	Anthraquinone reaction.....	Yes (Less than 0.5%)	

Weiss reports¹ that water-gas tar has a coefficient of expansion for 1° F. (length = 1) of 0.00035-0.00038. According to Downs and Dean,² water-gas tar contains substantial amounts of benzene, toluene, xylenes, naphthalene and anthracene. The nitrogenous bases and phenols are absent or nearly so. Weiss reports further that the percentage of free carbon varies from 1.04 to 1.087 per cent, with water-gas tars ranging in specific gravity from 1.078-1.090.³

Oil-gas Tars. These are manufactured from petroleum alone without the use of coal or coke. Several methods have been used, all embodying the same principle but differing in detail, the most important of which are as follows:

Pintsch Gas. This is manufactured by spraying petroleum in a closed retort constructed of iron or fire clay and heated to a temperature of 900 to 1000° C. by combustion of oil, gas or tar underneath. The shape of

¹ *J. Franklin Inst.* **172**, 277, 1911.

² *J. Ind. Eng. Chem.*, **3**, 108, 1911; also **6**, 366, 1914.

³ *J. Franklin Inst.*, **172**, 277, 1911.

the retort is shown in Fig. 102. The vapors pass to the rear and thence downward and through a lower chamber into the hydraulic main in front. The gases are passed successively through a scrubber, condenser and purifier.

Recently a modified form of apparatus has been used for manufacturing Pintsch gas under a high pressure, consisting of a heavy steel container filled with a checker-work of brick. The checker-work is first heated to a high temperature by introducing steam and air. Sometimes the resulting tar is used instead of the oil during the heating-run. When the proper degree of heat is obtained the air is shut off and oil with a small amount of steam is sprayed in under pressure. The main advantage resulting from the use of pressure is the greater yield of gas.

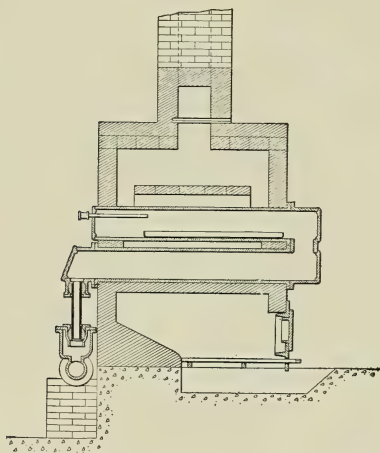

FIG. 102.—Pintsch Gas Retort.

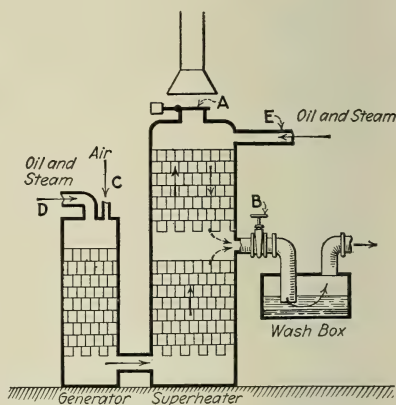

FIG. 103.—Oil-water Gas Plant.

Pintsch gas is used extensively for railroad and buoy lighting. It may be stored in holders under a pressure of 5 to 25 atmospheres, without suffering in illuminating power as would prove to be the case with most other gases adapted for lighting purposes.

About 10 per cent tar is recovered in the Pintsch process, the characteristics of which will be described under the heading "oil-gas tar" below.

Oil-water Gas. This process is used almost exclusively on the Pacific coast for manufacturing illuminating gas, owing to the absence of coal deposits.¹

The installation is shown diagrammatically in Fig. 103. The generator and superheater are filled with checker-works of brick. Assuming that

¹ "The Development of Oil-gas in California," *Proc. Am. Gas Inst.*, 4, 413, 1909.

the temperature of the brick work has been previously brought to the proper temperature for igniting petroleum vapors, the stack valve *A* is opened and valve *B* closed. For the first three minutes air (at a pressure of 7 to 9 in.) and steam (at a pressure of 35 lb.) are admitted through the valves *C* and *D* respectively at the top of the generator to start the run. At the end of the three minutes, petroleum heated to 150° F. is introduced through *D* (at a pressure of 8 lb.), and the heating continued for nine minutes. Then air is turned off at *C*, valve *B* opened, and valve *A* closed in the sequence named. Oil and steam are then introduced through the valves *D* and *E*, and allowed to continue eight minutes, whereupon the oil is shut off, and steam alone blown through the generator and superheater for two minutes to purge the apparatus of oil vapors. From the wash-box, the vapors are passed through scrubbers filled with a checker-work of wooden slats as shown in Fig. 63.

The top of the superheater acts as a reservoir to store heat. The take-off valve *B* is at the centre, because experience has shown that if the oil vapors were allowed to traverse the entire superheater during the gas-making period, the illuminants would be decomposed into methane, hydrogen and lampblack. The heat is controlled by the two sets of burners *D* and *E*. If the checker-work becomes overheated, more oil is introduced, and conversely if the temperature falls too low, less oil is used. If the temperature of the apparatus is too high, lampblack will separate out in the wash-box, while if it is too low an excessive quantity of tar will be produced. The tar is very similar to Pintsch-gas tar in its physical and chemical properties. During the gas-making period, the oil is kept at a pressure of 20 lb. in the generator and 25 lb. in the superheater.

It requires about 8 to 8½ gal. of crude oil per 1000 sq.ft. of gas, of which about one-fifth is required for heating and four-fifths for gas-making.

Blau Gas. This is a further development of Pintsch gas, and is made by cracking oil vapors at a temperature lower than in the Pintsch process (i.e. 550 to 600° C.), but in a similar form of retort. The resulting gases are first purified by passing in the usual manner through hydraulic mains, coolers, cleaners and scrubbers to remove the tar, which amounts to 4-6 per cent of the oil used, and then compressed in a three- or four-stage compressor to 100 atmospheres, which causes the high boiling-point constituents to liquefy and absorb a large proportion of the non-liquefiable gases. The excess of the latter is used for running the compressor and heating the retorts.

The compressed Blau gas is so constituted that upon releasing the pressure, the dissolved and liquefied constituents are evolved in such proportions that the composition of the gaseous mixture remains constant.

Blau gas is used principally for marine lighting purposes and transported in cylinders of about 1 cu.ft. capacity, carrying 20 lb. of the compressed gas, which will expand to about 250 cu.ft. at atmospheric pressure. Its illuminating value is greater than that of Pintsch gas.

The tar recovered from the Blau gas process is similar in its physical and chemical properties to the oil-gas tars described previously.¹

Properties of Oil-gas Tars. Dehydrated oil-gas tars produced by the Pintsch process, the oil-water gas process and the Blau gas process comply with the following characteristics:

(Test 1)	Color in mass.....	Black
(Test 2a)	Homogeneity to the eye.....	Uniform
(Test 2b)	Homogeneity under the microscope.....	Comparatively free from carbonaceous matter.
(Test 7)	Specific gravity at 77° F.....	0.95-1.10
(Test 8)	Viscosity.....	Moderate
(Test 9c)	Consistency at 77° F.....	0
(Test 13)	Odor on heating.....	Like water-gas tar
(Test 15a)	Fusing-point (K. and S. method).....	<0°-20° F.
(Test 16)	Volatile matter at 500° F., in 4 hrs.....	35-70%
(Test 17a)	Flash-point.....	Low
(Test 19)	Fixed carbon.....	10- 25%
(Test 21a)	Soluble in carbon disulphide.....	98-100%
(Test 21b)	Non-mineral matter insoluble.....	0- 2%
(Test 21c)	Mineral matter.....	0- 1%
(Test 22)	Carbenes.....	0- 2%
(Test 23)	Solubility in 88° naphtha.....	50- 85%
(Test 28)	Sulphur.....	<1%
(Test 30)	Oxygen.....	1- 2%
(Test 32)	Naphthalene.....	Trace
(Test 33)	Paraffine.....	0- 5%
(Test 35)	Sulphonation residue.....	20- 40%
(Test 37)	Saponifiable constituents.....	Trace
(Test 41)	Diazo reaction.....	Yes
(Test 42)	Anthraquinone reaction.....	Yes

When asphaltic petroleums are used to produce oil-gas tar, paraffine will be absent, but when non-asphaltic or mixed-base petroleums are used, it will be present in quantities not exceeding 5 per cent.

Water-gas and oil-gas tars are distinguished from coal-tars by the following.

- (1) Absence of associated ammonium compounds in the aqueous liquor.
- (2) Lower specific gravity.
- (3) Smaller percentage of "free carbon" (non-mineral matter insoluble in carbon disulphide).
- (4) Larger proportion soluble in carbon disulphide.
- (5) Presence of paraffine wax when mixed-base or non-asphaltic petroleums have been used.

¹"Blau Gas: A New Gas for Illuminating, Heating, and Power Purposes," by William Hallock, *J. Soc. Chem. Ind.*, **27**, 550, 1908; "The Manufacture and Use of Blau Gas," by Hugo Lieber, *Met. Chem., Eng.* **12**, 153, 1914.

(6) A substantial proportion of sulphonation residue, which considered in connection with the small percentage of mineral matter distinguishes them from blast-furnace tars.

Oil-gas tar may be distinguished from water-gas tar by the following:

- (1) Oil-gas tar as a rule has a lower specific gravity.
- (2) Water-gas tar yields a smaller percentage of sulphonation residue.

Refining of Water-gas and Oil-gas Tars. Oil-gas and water-gas tars when suitably dehydrated may be distilled in accordance with the methods used for "coal tar" (p. 246). Sometimes the water-gas-tar pitch or oil-gas-tar pitch is mixed with coal-tar pitch in suitable proportions.

Properties of Water-gas-tar Pitch and Oil-gas-tar Pitch. Water-gas-tar-pitch and oil-gas-tar pitch comply with the following tests:

	<i>Water-gas-tar Pitch.</i>	<i>Oil-gas-tar Pitch.</i>
(Test 1) Color in mass.....	Black	Black
(Test 2a) Homogeneity to the eye.....	Uniform	Uniform
(Test 2b) Homogeneity under the microscope.....	Small amount of carbon visible	Small amount of carbon visible
(Test 3) Aged surface.....	Variable	Variable
(Test 4) Fracture.....	Conchoidal	Conchoidal
(Test 5) Lustre.....	Bright	Bright
(Test 6) Streak.....	Black	Black
(Test 7) Specific gravity at 77° F.....	1.10-1.20	1.15-1.30
(Test 9b) Consistency at 77° F.....	10-100	10-100
(Test 9d) Susceptibility factor.....	>100	>100
(Test 10) Ductility.....	Variable	Variable
(Test 11) Tensile strength at 77° F.....	Variable	Variable
(Test 13) Odor on heating.....	Characteristic	Characteristic
(Test 14a) Behavior on melting.....	Pass rapidly from solid	Pass rapidly from solid
(Test 15a) Fusing-point (K. and S. method).....	80-275° F.	80-275° F.
(Test 15b) Fusing-point (B. and R. method).....	100-300° F.	100-300° F.
(Test 15c) Fusing-point (cube method).....	110-320° F.	110-320° F.
(Test 16) Volatile matter 500° F., 4 hrs.....	5-15%	5-15%
(Test 17a) Flash-point.....	300-400° F.	300-400° F.
(Test 19) Fixed carbon.....	25-40%	20-30%
(Test 21a) Solubility in carbon disulphide.....	85-98%	85-98%
(Test 21b) Non-mineral matter insoluble.....	2-15%	2-15%
(Test 21c) Mineral matter.....	0-1%	0-1%
(Test 22) Carbenes.....	2-15%	2-20%
(Test 23) Solubility in 88° naphtha.....	50-80%	65-85%
(Test 28) Sulphur.....	<4%	<4%
(Test 30) Oxygen.....	0-2%	0-2%
(Test 33) Paraffine.....	0-5%	0-5%
(Test 35) Sulphonation residue.....	0-15%	20-40%
(Test 37) Saponifiable matter.....	0-1%	0-1%
(Test 41) Diazo reaction.....	Yes	Yes
(Test 42) Anthraquinone reaction.....	Yes	Yes

Representative samples of water-gas-tar pitch and oil-gas-tar pitch tested by the author gave the following results:

	<i>Water-gas-tar Pitch.</i>	<i>Oil-gas-tar Pitch.</i>
(Test 3) Appearance surface aged 1 week.....	Bright	Bright
(Test 7) Specific gravity at 77° F.....	1.18	1.20
(Test 9b) Penetration at 115° F. (50 g., 5 sec.).....	235	166
Penetration at 77° F. (100 g., 5 sec.).....	20	6
Penetration at 32° F. (200 g., 60 sec.).....	2	1
(Test 9c) Consistency at 115° F.....	1.0	2.7
Consistency at 77° F.....	20.2	28.0
Consistency at 32° F.....	> 100	> 100
(Test 9d) Susceptibility factor.....	> 100	> 100
(Test 10b) Ductility at 115° F.....	50	65
Ductility at 77° F.....	85	44
Ductility at 32° F.....	0	0
(Test 11) Tensile strength at 115° F.....	0.2	0.4
Tensile strength at 77° F.....	4.0	7.5
Tensile strength at 32° F.....	7.2	6.0
(Test 15a) Fusing-point (K. and S. method).....	102° F.	128½° F.
(Test 15b) Fusing-point (B. and R. method).....	120° F.	149° F.
(Test 15c) Fusing-point (cube method).....	134° F.	159½° F.
(Test 16) Volatile matter 500° F., 4 hrs.....	10.2%	7.8%
(Test 17a) Flash-point.....	328° F.	365° F.
(Test 19) Fixed carbon.....	27.7%	25.1%
(Test 21a) Soluble in carbon disulphide.....	97.3%	87.8%
(Test 21b) Non-mineral matter insoluble.....	2.5%	11.8%
(Test 21c) Mineral matter.....	0.2%	0.4%
(Test 22) Carbenes.....	9.2%	4.7%
(Test 35) Sulphonation residue.....	8.2%	30.7%
(Test 37) Saponifiable matter.....	0.2%	0.7%

Water-gas-tar and oil-gas-tar pitches may be distinguished from coal-tar pitches by:

(1) The small percentage of "free carbon" (non-mineral matter insoluble in carbon disulphide).

(2) The possible presence of paraffine wax (when non-asphaltic or mixed-base petroleums are used).

On the other hand, water-gas-tar pitch may be distinguished from oil-gas-tar pitch by the following:

(1) Lower specific gravity of water-gas-tar pitch.

(2) Larger percentage of sulphonation residue from oil-gas-tar pitch.

Both of these pitches are largely susceptible to changes in temperature, they are highly resistant to the prolonged action of moisture, and are adapted for manufacturing low-priced solvent paints because of their ready solubility in "coal-tar naphtha."

CHAPTER XIX

PETROLEUM ASPHALTS VARIETIES OF PETROLEUM

“PETROLEUM asphalts” are obtained from petroleums by distillation, blowing with air at elevated temperatures, and refining with sulphuric acid. These methods will be described in greater detail later.

Petroleum as it occurs in different parts of the world, varies widely in composition. Certain varieties are composed entirely of open chain hydrocarbons (p. 30), others are made up exclusively of cyclic hydrocarbons (p. 34), and still others occur showing every possible gradation between these two extremes. Numerous classifications have been proposed, based on its chemical composition in general, or the presence of a substantial proportion of characteristic bodies, such as the paraffine series of hydrocarbons, the naphthene series, sulphur derivatives, nitrogenous bodies, benzols, terpenes, etc.¹

From the standpoint of the *solid* hydrocarbons present, petroleums may be divided into three groups, viz.:

- (1) Bearing a substantial quantity of solid paraffines.
- (2) Bearing a substantial proportion of asphaltic bodies.
- (3) Of mixed composition, bearing both solid paraffines and asphaltic bodies.

The solid paraffines are usually associated with open chain hydrocarbons, and the asphaltic bodies with the cyclic hydrocarbons. The two extreme types of petroleum, and the innumerable intermediate groups are represented empirically as follows:

<i>Extreme Types</i>	<i>Intermediate Types</i>	<i>Extreme Types</i>
Composed of open-chain hydrocarbons. Presence of solid paraffines. Absence of asphalt (i.e., “non-asphaltic.”) Sulphur and nitrogenous bodies may or may not be present.	“Mixed Base Petroleums”	Composed of cyclic (aromatic) hydrocarbons. Absence of solid paraffines. Presence of asphalt (i.e., “asphaltic.”) Sulphur and nitrogenous bodies generally present.

¹ For a detailed consideration of this complex subject, the reader is referred to the excellent works of C. Engler and H. v. Höfer, C. F. Mabery, K. W. Charitschkoff, N. A. Kwjatkowsky, M. A. Rakusin, etc.

Open chain hydrocarbons predominate in the petroleum produced in the Appalachian field (Pennsylvania, New York, southeastern Ohio, West Virginia, Kentucky and Tennessee), the Lima-Indiana field (embracing western Ohio and Indiana), the Canadian and the Alaskan oil fields. These are non-asphaltic, and generally carry solid paraffines.

Both open-chain and cyclic hydrocarbons are present in the petroleum produced in the Illinois, the Mid-continental (extending over Kansas, Oklahoma, northern Texas and northern Louisiana in the neighborhood of Caddo and De Soto) and in the Mexican oil fields. These are representative of the mixed-base petroleum, and carry both asphalt and the solid paraffines.

Cyclic hydrocarbons predominate in petroleum produced in the Gulf field (including southern Texas and southern Louisiana), the California field and the Trinidad field. These are representative of the asphaltic petroleum, and are usually free from solid paraffines.

The following refineries producing petroleum asphalts were reported operative in the United States during 1916:

California:	16 refineries utilizing California crude oil
Illinois:	3 refineries utilizing Illinois oil 1 refinery utilizing Kansas and Oklahoma oils
Indiana:	1 refinery utilizing Oklahoma and Kansas crudes
Louisiana:	1 refinery utilizing Texas crude 2 refineries utilizing Mexican crude
Maryland:	3 refineries utilizing Mexican crude
Missouri:	1 refinery utilizing Oklahoma and Kansas crudes
New Jersey:	2 refineries utilizing Mexican crude
New York:	1 refinery utilizing Mexican crude
Ohio:	1 refinery utilizing Mexican and Illinois crudes
Pennsylvania:	1 refinery utilizing Mexican crude
Texas:	3 refineries utilizing Texas crude 2 refineries utilizing Texas and Mexican crudes 1 refinery utilizing Mexican crude exclusively.

PRODUCTS OBTAINED FROM PETROLEUM

There is great confusion in the nomenclature of the products derived from the distillation and refining of petroleum. Many terms have been suggested, both scientific and proprietary, but no *standard* system of terminology has been adopted for the purpose, much as it would be welcomed by the industry.

In general, petroleum distillates are classified into seven groups, and the residual products into six. Each group is designated by various names, in some cases depending upon the use to which the material is to be put, in others, upon its physical characteristics, and in still others by fanciful terms having no special significance. These will be considered in greater detail.

Distillates

(1) **Gasoline.** The best practice restricts the use of the word "gasoline" to light petroleum distillates suitable for gasification in a vaporizer, as for example, in a gas machine, gasoline torch, gasoline stove, automobile carburetor, etc. The term gasoline has been variously referred to by the following expressions:

Petroleum Ether. This is sometimes applied to products ranging in specific gravity from 0.590-0.700 (108-70° Baumé), occasionally termed cymogene (108-90° Baumé, equivalent to 0.590-0.636), canadol (85-70° Baumé, equivalent to 0.650-0.700), rhigolene (103° Baumé, equivalent to 0.600) or Sherwood oil (boiling between 40 and 70° C.). These expressions are rarely used.

Petroleum Spirits. A term rarely applied to products ranging in specific gravity from 0.679-0.745 (76-58° Baumé).

Light Petroleum. A term infrequently applied to distillates varying in specific gravity from 0.642-0.729 (88-62° Baumé).

Ligroïn. A name indiscriminately applied abroad to the lower boiling-point fractions; synonymous with "petrol" or "light petroleum"; used to designate gasoline for operating automobile motors.

(2) **Naphtha.** The terms "gasoline" and "naphtha" are generally used synonymously, but the best practice restricts the word "naphtha" to light petroleum products used as solvents, as for example by varnish and paint makers, soap makers, cleaners, etc., fractionated after the gasoline and before the kerosene. The following terms have also been employed to designate this product:

Benzine or Benzoline. These are used to a limited extent synonymously for naphtha.

"V. M. & P. Naphtha." This is an abbreviation for "varnish makers and paint naphtha," and is used to designate a solvent suitable for manufacturing varnishes and paints.

Turpentine Substitute. A closely fractionated distillate between naphtha and kerosene, having a fairly high flash-point (between 80 and 105° F., open cup test).

Cleaning Oil. A low boiling-point naphtha used for "dry cleaning" purposes.

NOTE. Naphthas are distinguished by their specific gravity, expressed in degrees Baumé; thus 62° naphtha refers to a product having a gravity of 62° Baumé (sp. gr. 0.729), etc.

(3) **Kerosene.** This term is applied to the distillate fractionated after the "naphtha" and before the "gas or fuel oil," suitable for burning in lamps or stoves by means of a wick, either for illuminating or heating purposes. Kerosenes are distinguished by their gravity expressed in degrees Baumé, by their fire test (temperature at which the vapors ignite), or by their color (thus, "W. W." or "water-white" kerosene is colorless, "prime-white" has a straw color, "standard-white" a pale yellow color, etc.). The following terms have been used synonymously for kerosene, viz.: illuminating oil, lamp oil, burning oil, stove oil, coal oil, carbon oil, white oil, head-light oil, signal oil, engine distillate, etc.

(4) **Gas or Fuel Oil.** These expressions, also sometimes designated "intermediate oils," or "middlings," are applied to the distillate obtained between "kerosene" and "lubricating oil." They usually have a high boiling-point (600-650° F.) and a low gravity (30-42° Baumé). This distillate is termed "gas oil" when it is used for enriching illuminating gas (p. 231) or for manufacturing carbureted water gas (p. 256), and it is called "fuel oil" when used for power or heating

purposes (viz., for firing steam boilers, locomotives, heating retorts, smelting, etc.). "Fuel oil" is sometimes referred to under the names "power distillate," "orchard oil," or "smudge oil" (i.e., when burnt in orchards to keep away frost).

(5) **Lubricating Oil.** This distils over after the "gas or fuel oil." In the case of paraffine-bearing petroleums, paraffine wax is separated from the lubricating oil by cooling and filtering. Lubricating oil has been exploited under various fanciful names, likewise appellations indicative of the use for which it is intended, including the following: neutral oil, spindle oil, cylinder oil, mineral sperm oil, mineral seal oil, mineral colza oil, paraffine oil, straw oil, machine oil, engine oil, gas-engine oil, automobile oil, compressor oil, ice-machine oil, dynamo oil, harvester oil, cream-separator oil, transformer oil, floor oil, etc.

Lubricating oils are designated by their viscosity (in terms of the Saybolt A viscosimeter), their specific gravity (degrees Baumé), and flash-point. For certain purposes they must withstand low temperatures without solidification, and for others, high temperatures without carbonization or appreciable loss of volatile constituents.

(6) **Paraffine Wax.** This is derived from paraffine-bearing petroleums, being separated from the lubricating oil and paraffine distillates by crystallization at low temperatures and filter-pressing. It is distinguished by its color and melting-point. The terms "paraffine scale" and "scale wax" are generally applied to the low melting-point variety, and "refined paraffine wax" to the harder variety. Its melting-point varies from 100–135° F. (see p. 307).

(7) **Wax Tailings.** This represents the fraction obtained in the dry distillation of petroleums, and recovered immediately prior to coking. It is peculiar in its properties and generally free from paraffine wax (see p. 310).

Residues

The following represent the various classes of residual products obtained in distilling petroleums:

(1) **Residual Oil.** This term is applied to the residue obtained from the dry distillation of paraffine-bearing petroleum, the steam or the dry distillation of mixed-base petroleums, and the steam distillation asphalt-bearing petroleum. It is characterized by being liquid or semi-liquid at room temperatures. The following terms are used synonymously with residual oil, viz.: asphaltum oil, liquid asphalt, black oil, flux oil, petroleum tailings and sometimes also fuel oil. When it is derived from paraffinaceous petroleum it is sometimes called "paraffine flux."

NOTE. *Road Oil and Dust-laying Oil*, are terms applied to the residual asphalts of liquid to semi-liquid consistency used for laying particles of dust on roads, including also the harder residual asphalts rendered liquid by dissolving in "gas or fuel oil," the solvent being supposed to evaporate slowly in time, leaving the dust particles covered with an adherent film.

(2) **Residual Asphalt.** This is applied to the residues obtained from the steam or dry distillation of mixed petroleums and the steam distillation of asphalt-bearing petroleum. It is characterized by being semi-solid to solid at room temperature.

NOTE. *Road-binder.* This term is applied to residual asphalt distilled to the proper consistency, or mixtures of residual asphalt with blown asphalt. These are not supposed to evaporate and are used for binding road-making materials

together. The term is used synonymously with "carpeting medium" and "seal-coating material."

(3) **Blown Asphalt.** A term used to designate the products obtained by blowing air through residual oils at elevated temperatures (see p. 287). This term is used synonymously with "oxidized asphalt," "oxygenized asphalt," and "condensed asphalt."

(4) **Sulphurized Asphalt.** This term is applied to the product obtained by heating residual oil or residual asphalt with sulphur at a high temperature. This name is also used synonymously with "Dubbs asphalt," "Pittsburgh flux," or "Ventura flux."

(5) **Sludge Asphalt.** This term is applied to the asphalt-like product separated from the acid sludge produced in the refining of petroleum distillates with sulphuric acid. (See p. 303.) It is also known under the names "acid asphalt" and "acid-sludge asphalt."

(6) **Coke.** This is the residue produced in the dry distillation of non-asphaltic or mixed-base petroleums (see p. 282).

In addition to the foregoing, the following product is obtained by treating petroleum in a special way:

Petrolatum. This name is applied to a product obtained by diluting crude paraffinaceous petroleum with naphtha and then subjecting the mixture to a low temperature, when a residue settles out, which is drawn off and distilled until the naphtha is removed, whereupon it is decolorized by filtering through fuller's earth. It is likewise known under the names vaseline, petroleum jelly, liquid paraffine, etc.

DEHYDRATION OF PETROLEUM

Nearly all crude petroleums carry more or less water, some being entrained mechanically, and in other cases held in a state of emulsion. Before the petroleum can be distilled, the water must be separated. The following methods are used for the purpose:

(1) *Settling.* This method is similar to that described under tars on p. 181, and is only of value when the water is not emulsified with the oil. The oil is maintained at 100–150° F., with steam coils at the bottom of the tank to increase its fluidity and promote the water settling.

(2) *Heating under Pressure.* This method has given good results with certain viscous California petroleums (especially those obtained from the Coalinga district), in which the water is partly entrained mechanically, and partly carried in a state of emulsion. The method consists in passing the oil through coils of pipe heated in a furnace to 250–300° F. under pressure.¹ Upon releasing the oil at atmospheric pressure in an air-cooled tower 18 ft. high and about 16 in. in diameter, the globules of water are converted into steam and this with the light oils, are led from the top into a water-cooled condenser, where the oils are recovered. The residual oil is drawn off at the bottom. The plant is illustrated in Fig. 104. Another alternative consists in heating the petroleum under pressure in a closed

¹ Hardison, *Trans. Am. Inst. Mining Eng.*, 99, 637, 1915.

receptacle to allow the water and impurities to settle out, and then permitting it to cool quietly.¹

(3) *Milliff Hot-air System.* Air heated to 1000° F. is blown through a perforated pipe into a tank carrying the cold oil. This converts the water into steam and vaporizes a small quantity of light oils which are recovered by passing the vapors through a condenser.

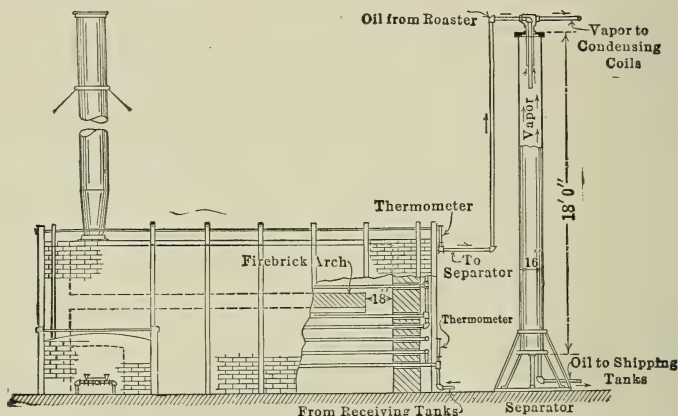

From "The American Petroleum Industry," by Bacon and Hamor.

FIG. 104.—Plant for Dehydrating Petroleum.

(4) *Electrical Method.* This has been perfected by Cottrell, and is similar to Method 7 described under "Tar" on p. 180, consisting in subjecting the crude petroleum to a current of 10,000 to 15,000 volts.

METHODS OF REFINING PETROLEUM

The dehydrated petroleum is separated into various commercial products by fractional distillation² (see p. 266). The process may be intermittent or continuous. Both systems are in vogue, and each will be considered separately.

Intermittent Distillation Processes. Petroleum may be distilled intermittently in either horizontal or vertical stills. Horizontal stills are set in brick walls which may be carried up on all four sides so that the still is completely enclosed, or else the ends may be allowed to project free. In the usual form, cast-iron lugs are riveted to the sides and allowed to rest on the brick work. In another form, metal loops are riveted to the top of the still, to engage hooks supported by "I" beams resting directly on the

¹ U. S. Pat. 890,762 of Jun. 16, 1908 to J. A. Dubbs.

² "American Petroleum Industry," by Bacon and Hamor; "The Manufacture of Petroleum Products," by F. G. Robinson, *Met. Chem. Eng.*, **11**, 389, 1913; "Das Erdöl," by Engler-Höfer, loc. cit.

brick walls or on metal columns outside of the setting. The walls are usually carried up half-way, the ends and upper portion of the still being covered with some non-conductive material to prevent radiation and loss of heat.

Heating is effected by means of gas, oil or coal, depending upon which may be procured cheapest locally. Gas or oil is introduced through specially constructed burners, and coal is burnt on a simple form of grate. The stills may be fired either at the ends or the sides, the latter giving a more uniform distribution of heat. Modern stills are made large enough to carry 1000 to 1500 barrels (of 42 gal. each). The diameter varies

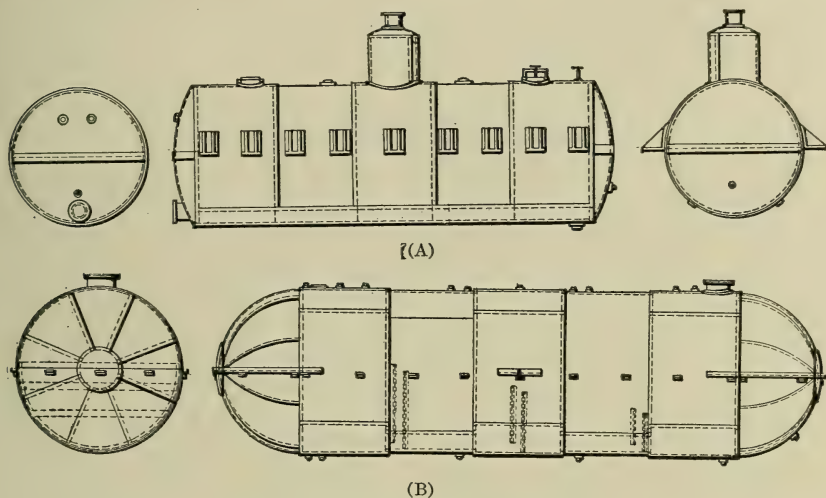

FIG. 105.—Horizontal Petroleum Stills.

from 10 to 15 ft., and the length from 40 to 50 ft. Two forms of an 800- to 900-barrel still are shown in Figs. 105A and 105B, the former being equipped with a dome and the latter without.

A vertical still of greater diameter than height with a dome-shaped top and a concave bottom was formerly used extensively in this country. It is popular abroad, and is occasionally encountered in the United States, but is rapidly going out of use (some are used in the Kansas and Pennsylvania oil fields, 16 ft. in diameter and 10 ft. high, mounted over a series of arches).

The vapors from the still (A) are led to the condenser, consisting of coils of pipe (*M*) surrounded with water in the tank (*L*). The condensate is conveyed through "running lines" (*O*) to the "tail house" (*N*) where the lines are provided with "look-boxes" (*P*) so the operator may

ascertain the gravity and observe the appearance of the distillate. From the look-boxes the lines connect with a manifold (*Q*) to deflect the "stream" into any desired receiving tank. The installation is illustrated diagrammatically in Fig. 106. The fuel is burnt on the grate (*E*), the hot gases passing over the fire-arch (*C*) into the flue (*D*). The ash-box is represented by (*B*), the pipe for introducing steam by (*G*), and the pipe for drawing off the residual by (*H*).

The intermittent distillation may be carried on either with or without the use of steam. When steam is employed, the process is known as "steam distillation," otherwise it is termed "dry distillation."

(1) *Dry Distillation*. This is sometimes termed the "straight" or "destructive" or "cracking" process, by means of which a certain

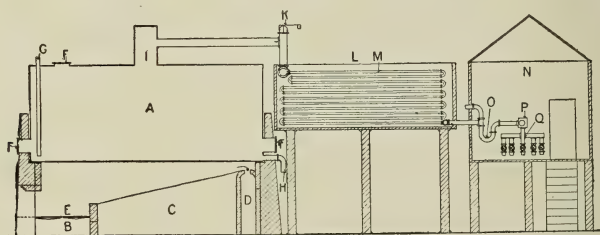

FIG. 106.—Plant for Refining Petroleum.

proportion of the higher boiling-point constituents decompose or break down, forming correspondingly larger yields of the low boiling-point constituents. The dry distillation process is accordingly used when the distiller wishes to produce the maximum amount of gasoline and illuminating oil, or in cases where the crude is unfit for manufacturing lubricating oil. Non-asphaltic petroleums are ordinarily treated by this method on account of the high price commanded by their low boiling-point distillates. In this process the complex molecules are broken down into simpler ones upon subjecting them to a prolonged heating at temperatures at which they are unstable.

(2) *Steam Distillation*. This is also termed the "fractional" distillation process and consists in introducing dry steam, termed "bottom steam" into the still, which assists in the vaporization of the volatile constituents and minimizes decomposition of the distillate and residue. Its action is based on the physical law that the boiling-point of a pair of non-miscible or slightly miscible liquids is lower than that of either pure component. The introduction of steam, therefore, serves to materially lower the boiling-point of the petroleum, and produces the maximum yield of heavy lubricating oils. It also tends to economize in fuel, and to shorten

the distillation process. The steam upon being dried by passing through a trap is introduced through perforated pipes at the bottom of the still, only when the temperature of the contents exceeds the boiling-point of water.

Sometimes a partial vacuum is used in conjunction with steam to still further reduce the tendency towards cracking, thus increasing both the quantity and quality of the distillates, and reducing the duration of the process. This is based on the well-known physical law whereby the boiling-point of a liquid decreases with a reduction in atmospheric pressure.

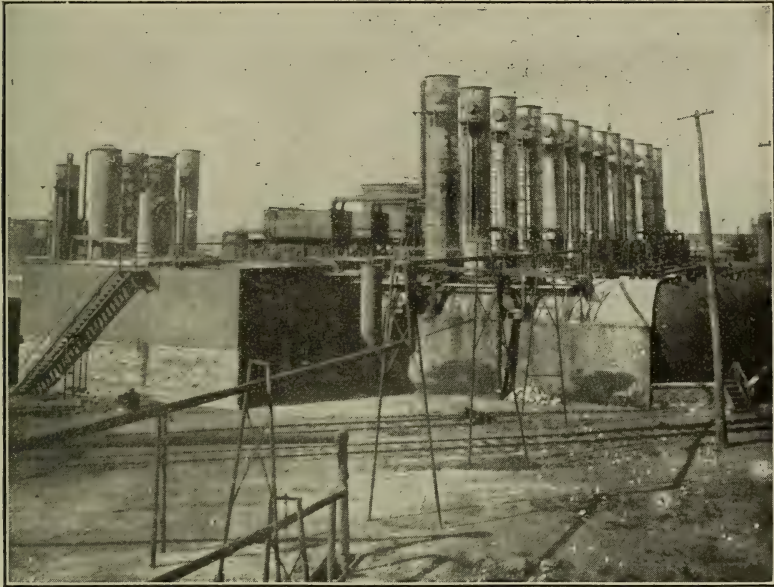

From "The American Petroleum Industry," by Bacon and Hamor.
FIG. 107.—Tower System for Distilling Petroleum.

Another modification consists in interposing a series of air-cooled "towers" between the still and the condenser. These act as dephlegmators, and result in a sharp separation of the various fractions, since the condensation which takes place in the towers washes the ascending vapors and purifies them. The vapors are conducted from the bottom of one tower to the top of the next, and so on, and separated into as many fractions as there are towers. This obviates the necessity of redistilling the fractions. The tower system is illustrated in Fig. 107.

Continuous Distillation Processes. The continuous process was first perfected in Russia and is now being used very largely in the United States, particularly in the Gulf and California oil fields.

Numerous methods have been suggested and tried for distilling petroleum continuously, only two of them, however, have come into use generally, viz.: the "topping process" and the Livingston process. They reduce the cost of treatment, increase the output of the plant, and effect a sharper and cleaner fractioning of the distillates. Steam may or may not be used.

(1) *Topping Process*. This is also known as the "skimming" process, the object of which is to distil the gasoline, naphtha, kerosene, and in certain cases the gas or fuel oil without, however, removing the lubricating oil. Most of the refineries in the California, Louisiana, Texas and Mexican fields do not produce lubricating oils on account of the inferior products derived from the respective petroleum. As a much more expensive equipment is required to manufacture lubricating oil, even when the crude does contain good lubricating fractions, refiners will often avail themselves of the topping process to reduce the cost of equipment and plant.

Various forms of topping plants are used, all operating in accordance with the principle employed for dehydrating petroleum by "Heating under Pressure" (see p. 269). The oil is first passed through coils of pipe and heated under pressure in a furnace, and then allowed to expand into a vertical separating chamber where a suitable spreader causes it to flow downward over the walls in a thin film. The uncondensed vapors are withdrawn from the top and passed through a water condenser. The topped oil flows from the bottom into a heat exchanger where it transfers a good portion of the heat to the crude oil on its way to the furnace. The exchanger consists of pipes surrounded by wall-insulated pipes of larger diameter. The crude oil is passed through the inner pipes and the topped residuum through the outer ones. A typical illustration is shown in Fig. 108.

The liquid to semi-liquid residuum obtained from the topping process is marketed under the names "asphaltum oil," "residual oil," "fluxing oil" or "road oil," or if the distillation is carried further, the residue may become almost solid in consistency when cold, in which event live steam is introduced into the separating chamber to facilitate the removal of the volatile constituents and prevent the residue from becoming cracked and deteriorating in quality.

(2) *Livingston Process*. This was perfected by Max Livingston of the Atlantic Refining Company, Philadelphia, the apparatus being illustrated in Fig. 109.¹ It consists of eleven or more stills arranged side by side on a masonry foundation (36), with a separate fire chamber (12) underneath each still. The crude petroleum passes through the supply pipe (27)

¹ U. S. Pat. 728,257, May 19, 1903.

into still No. 1 (on the left of the figure) which is provided with an internal steam coil (17) to precipitate any water and earthy matter carried

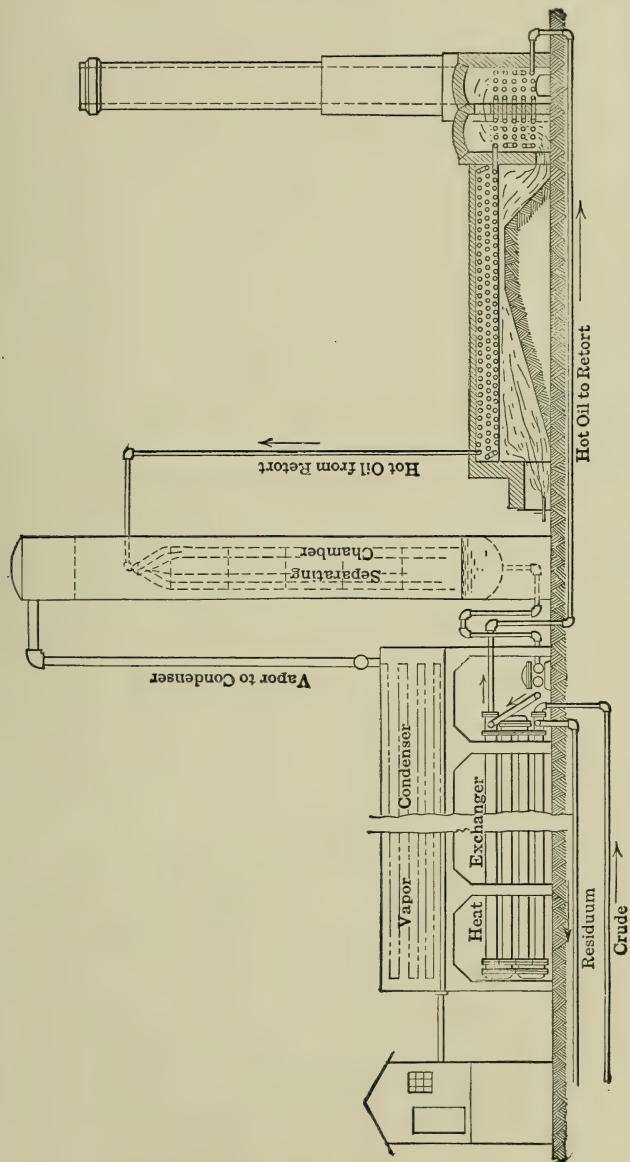

From "The American Petroleum Industry," by Bacon and Hamor.
 FIG. 108.—Topping Plant for Refining Petroleum.

by the oil. The vapors generated in this still are drawn off through the vapor pipe (16).

The oil freed from water and earthy matters then passes into still No. 2 (shown to the right of the first still), provided with a steam pipe (30) connected with a branch (31) leading to the bottom of the still to assist heating the oil, also with a series of fire flues (14) for the same purpose. Successive pairs of stills are alternately connected together at opposite ends by U-shaped connections (19), joined by elbows (20) to stand-pipes (21) inside the stills, the heights of which predetermine the liquid levels. Each stand-pipe (21) is surrounded by a sleeve (35) open at both ends, the upper end rising above the liquid, and the lower reaching a point near the bottom of the still. This device conveys the liquid from the *bottom* of the still into the following one.

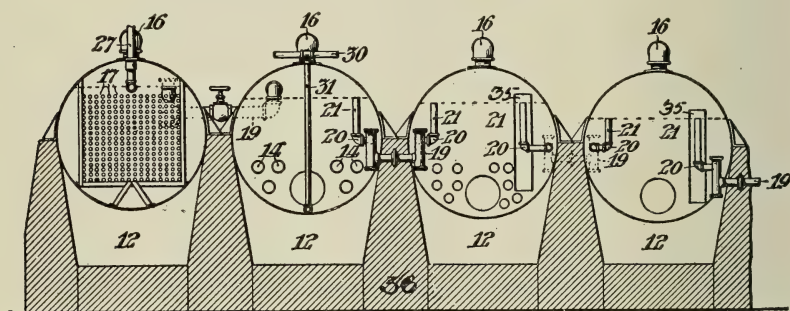

FIG. 109.—Livingston Apparatus for Continuous Distillation of Petroleum.

The upper end of the stand-pipe (21) is brought to a slightly lower level in each succeeding still, so that the oil will flow by gravity through the entire series. The height in each still is adjusted to compensate for the diminution in the volume of its contents corresponding to the quantity of distillate removed. The vapor-space above the liquid in the series of stills increases as the distillation progresses and results in the production of purer distillates, due to a partial condensation of the higher boiling-point products, which wash the vapors in a manner similar to that which takes place in the "tower system" (p. 273).

The vapors from each still are passed through separate condensers which recover fractions of uniform composition. The number of fractions depends upon the number of stills in use, the heavy residuum being withdrawn from the last one through the pipe (19).

An ingenious series of pipes is provided so that in case any still needs repairing it can be temporarily cut off, and substituted with another.

The process is readily controlled, economical to operate, and results in more uniform and better quality distillates. It is equally adaptable

to the dry and steam distillation processes, also for distilling light fractions as well as heavy lubricating oils.

Steam Distillation of Asphalt-bearing Petroleum. In practice, asphaltic petroleum is subjected either to the "steam distillation process" (see p. 272) or to the "topping process" (see p. 274). The distillation is designed to separate:

(1) Gasoline, naphtha, kerosene, and in some cases the gas or fuel oil, in which event the residuum will be of a liquid or semi-liquid consistency, designated "residual oil."

(2) Gasoline, naphtha, kerosene, gas or fuel oil, and lubricating oil, in which event the residuum will be of a semi-solid to solid consistency, designated "residual asphalt."

The charge of petroleum is distilled until the residue attains the proper consistency, which is controlled by sampling the residue through petcocks set in the still, or by recording the temperature of the residue, or by observing the character of the distillate. The further the process is continued, the higher the fusing-point and the harder the consistency of the residue. The temperature of the residue at the termination of the process will vary between 600 and 750° F., and the time of distillation between twelve and thirty-six hours. When the distillation is completed, the residuum is run or blown into a closed cylindrical vessel constructed of steel, where it is allowed to cool until the temperature is reduced sufficiently to permit its being filled into barrels or drums without danger of igniting on coming in contact with air.

Where the residue is distilled to a definite consistency without further treatment, the distillation is known as "straight running," and the residue a "straight run asphalt." In certain cases a portion or "fraction" of the distillate is mixed with the residue at the close of the distillation, which is termed "cutting back," the object of which is to modify the properties of the residual product or to economically dispose of a fraction which otherwise has little value commercially.

If the process of distillation is conducted too rapidly, or the temperature is permitted to rise too high, the residue "cracks" and becomes altered in composition, usually with the simultaneous formation of considerable carbonaceous matter.

Table XXI shows an outline of the steam distillation process of treating asphalt-bearing petroleum, including the production of lubricating oil.

Steam Distillation of Asphaltic Petroleum:

TABLE XXI

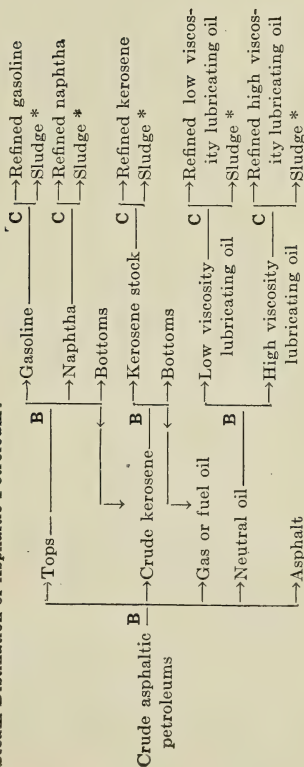

Steam Distillation of Non-asphaltic and Mixed-base Petroleums:

TABLE XXII

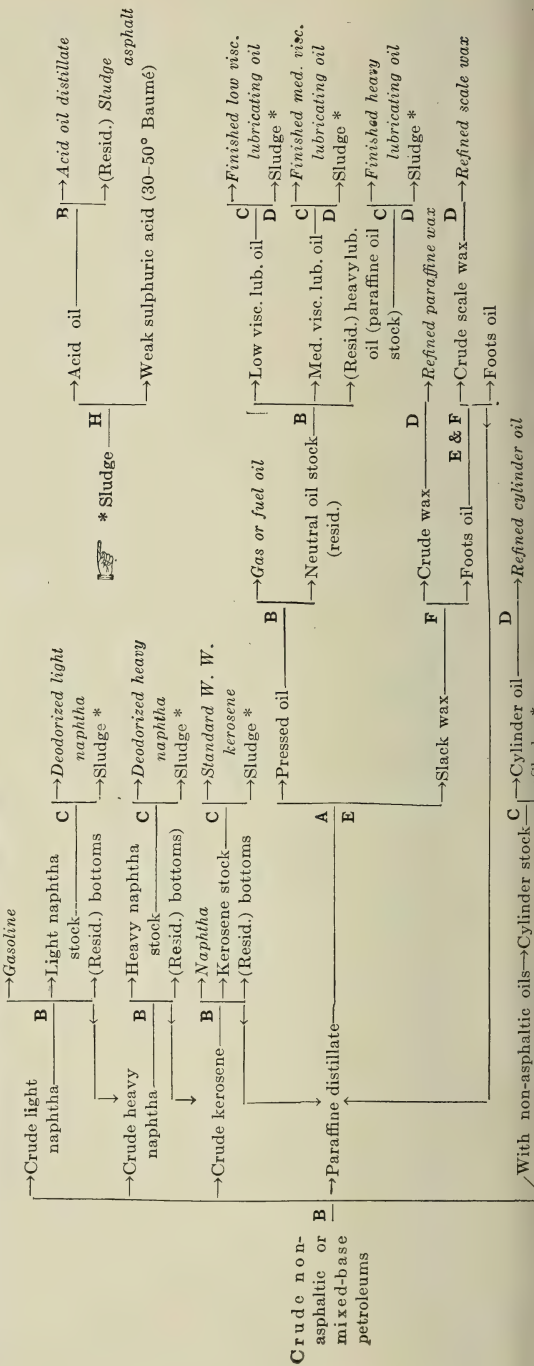

Legend

- A Dry Distillation.
- B Steam Distillation (or "Fractional Distillation").
- C Purification with Sulphuric Acid, Caustic Soda, and Water.
- D Filtration through Fuller's Earth.
- E Cooling to 20-25° F. and Filtering.
- F Sweating.
- G Brightening with Air-jets.
- H Steaming.

Dry Distillation of Non-asphaltic and Mixed-base Petroleum:

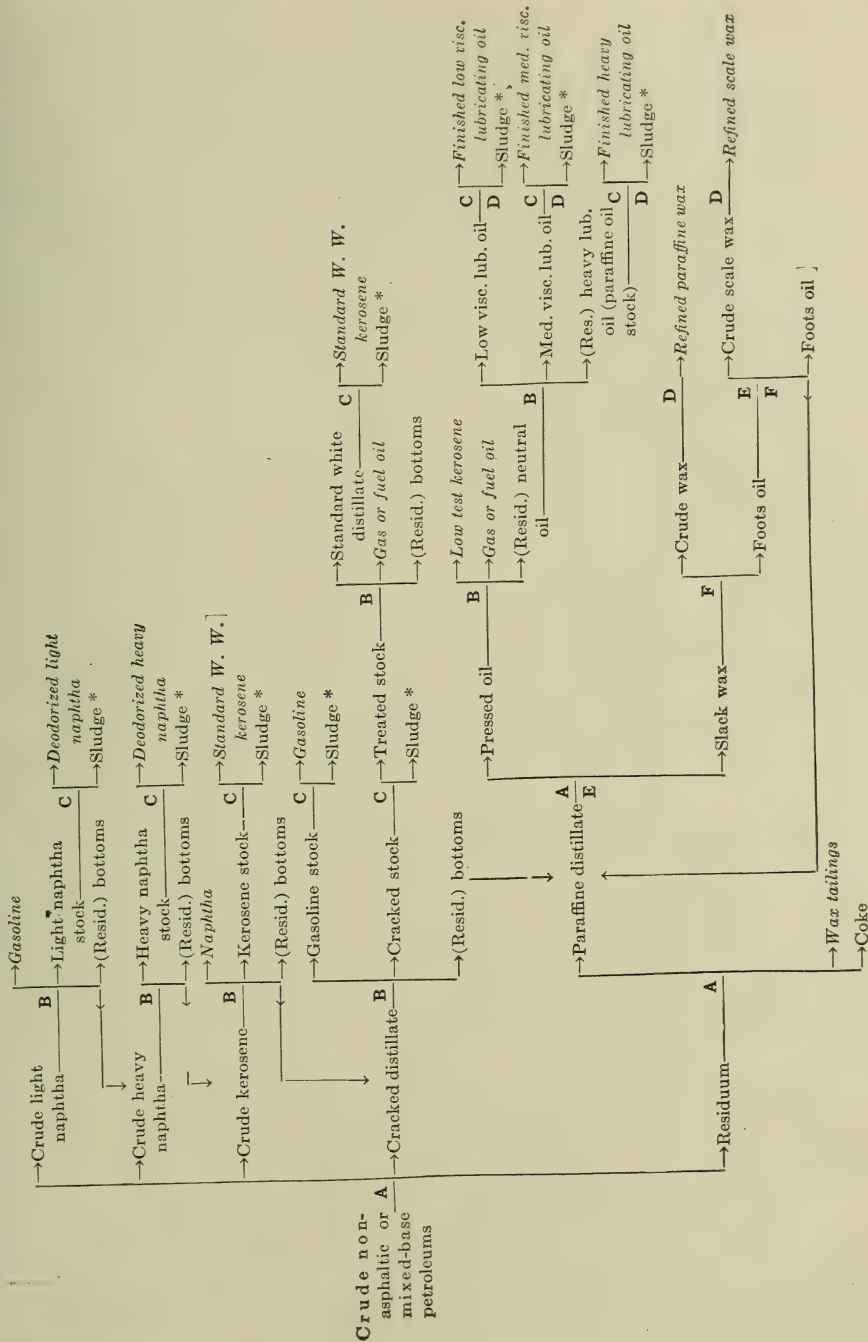

The following products are obtained:¹

Gasoline.....	Of 60° Baumé
Light naphtha ("No. 1 Tops").....	Of 55° Baumé
Heavy naphtha.....	Of 50 and 45° Baumé respectively
Kerosene.....	Ranging from 40 to 48° Baumé
Gas or fuel oil, including a product marketed as "orchard heating oil," or "smudge oil," ranging from 26-28° Baumé (burnt in orchards to prevent frost from damaging the trees), also a fuel oil of 27° Baumé, having a flash-point of 150° F.	
Lubricating oil.....	Ranging from 17 to 25° Baumé
Residual asphalt.....	Of varying hardness and fusing-point
Road oil.....	Varying in gravity from 20-18° Baumé

The following yields are obtained from California asphaltic petroleum:²

Gasoline (60° Baumé).....	Trace-20%
Naphtha (55° Baumé).....	Trace-15%
Kerosene (35-42° Baumé).....	Trace-30%
Gas or fuel oil (25-30° Baumé).....	10-40%
Lubricating oil (17-25° Baumé).....	15-70%
Residual asphalt.....	20-40%
Loss.....	1-4%

Steam Distillation of Non-asphaltic and Mixed-base Petroleums. The object of this process is to avoid cracking, and obtain the maximum yield of lubricating oil. The stills are charged four-fifths full with the oil and the fires lighted. When the temperature reaches 280° F., all of the crude light naphtha has distilled off, whereupon steam is introduced through perforated pipes at the bottom, at first slowly, and then more rapidly as the distillation progresses. The procedure is shown diagrammatically in Table XXII, p. 278.

The crude heavy naphthas have distilled off when the temperature reaches 330° F. (about 145° lower than when distilled dry), the crude kerosene when the temperature reaches 500° F., (about 125° lower than when distilled dry), and the paraffine distillate when the temperature reaches 620° F. At this point the distillation is stopped. In the case of non-asphaltic crude oil, the so-called "cylinder stock" remains in the still, and with mixed-base crude, an asphaltic residue remains behind, which may either be marketed as such, or treated with air to produce a "blown asphalt."

The following yields are obtained:

	Non-asphaltic Petroleum.	Mixed-base Petroleum.
Crude light naphtha.....	10-15%	8-13%
Crude heavy naphtha.....	10-12%	8-13%
Crude kerosene.....	35-50%	20-35%
Paraffine distillate.....	15-25%	20-30%
Cylinder stock.....	8-15%
Residual asphalt.....	15-20%
Loss.....	2-4%	2-4%

¹ "The American Petroleum Industry," by Bacon and Hamor, 1st edition, p. 503.

² Bulletin No. 32, California State Mining Bureau.

Crude light naphtha, crude heavy naphtha, and crude kerosene are refined further by subjecting them to:

- (1) A second steam distillation.
- (2) A chemical treatment with sulphuric acid and caustic soda.

The paraffine distillate is subjected to a second dry distillation to convert the paraffine into a crystalline form which may be filtered more readily. The distillate is then cooled to 20 or 25° F. and filter-pressed (see p. 307), to separate the so-called "pressed oil" from the "slack wax." The pressed oil is then steam-distilled to separate the gas or fuel oil from the neutral oil stock, and the latter is again steam-distilled to fraction the various lubricating oils, which are finally purified with sulphuric acid and caustic soda. The slack wax is treated as described on p. 308. The cylinder stock obtained as a residue from non-asphaltic petroleum is first treated with sulphuric acid and caustic soda and then filtered through fuller's earth (a variety of clay obtained in Florida and Georgia, of fine texture and low specific gravity which has the property of retaining any dark-colored constituents). The distillate is forced through an upright cylinder having a perforated bottom, and holding 10 to 20 tons of the fuller's earth, under the combined influence of heat and pressure.

The following commercial products are obtained by the steam distillation of non-asphaltic and mixed-base petroleums:

Gasolines varying in gravity from 76–86° Baumé;

Deodorized Light Naphthas varying in gravity from 60–74° Baumé, including:

V. M. & P. Naphtha (Benzine) having a gravity of 63° Baumé;

Deodorized Heavy Naphthas varying in gravity from 54–58° Baumé;

Kerosenes varying in gravity from 54–38° Baumé; including products of

52° Baumé and 130° F. fire test ("Export Oil");

49° Baumé and 130° F. fire test;

48° Baumé and 155° F. fire test;

47° Baumé and 150° F. fire test;

41–38° Baumé ("Mineral Colza Oil"); etc.

Gas or Fuel Oils ranging in gravity from 38–36½° Baumé;

Lubricating Oils ranging in gravity from 30–32° Baumé, including:

the "non-viscous lubricating oils" (having a viscosity under 150 on the Saybolt "A" Viscosimeter), and the "viscous lubricating oils" (having a viscosity between 150 and 240).

Paraffine Waxes, including:

"Yellow Crude Scale," "White Scale," and "Refined Wax." The fusing-points range from 110–130° F., and are ordinarily marketed in grades of 118–120° F., 122–124° F., 124–126° F., and 126–128° F.

Refined Cylinder Oils for use in steam cylinders at high temperatures, ranging in flash-point from 540–630° F., with fire-points from 550–750° F. The higher the fire- and flash-points, the more valuable the oil.

Dry Distillation of Non-asphaltic and Mixed-base Petroleums. The object of the dry or "cracking" distillation of petroleum is to increase the yield of the low boiling-point products, including the gasolines and naphthas. The distillation is carried on in the following manner: when the temperature of the oil in the still reaches 175 to 200° F., gaseous products are first evolved, followed by the "crude light naphtha," which continues to come over until the temperature in the still reaches about 320° F. At this temperature the "crude heavy naphtha" commences to distil and is fractioned until the temperature reaches 475° F. Then the crude kerosene commences to boil over, and is fractioned until the contents of the still reach 625° F. A large amount of "cracking" commences at this point, and the fires are accordingly moderated to slow down the distillation and accelerate the decomposition as much as possible. The "cracked" distillate is fractioned until the temperature in the still reaches 675 to 700° F., whereupon the distillation is brought to a close. There remains a viscous dark-colored "residuum" varying in gravity from 20 to 25° Baumé which may either be marketed under the name of "residual oil" or "flux oil" or else distilled separately. The method of procedure is illustrated in Table XXIII, p. 279.

The crude light naphtha, crude heavy naphtha and crude kerosene are treated as described under the steam distillation process of non-asphaltic and mixed-base petroleums. The cracked distillate is steam-distilled, and the respective fractions purified with sulphuric acid and caustic soda, and the gasoline, kerosene and gas or fuel oil separated in the manner outlined in the table.

When the residue is dry distilled in a separate still known as a "tar still," the operation is carried on as rapidly as possible to avoid unnecessary cracking, and render the paraffine crystalline. The paraffine distillate comes over first, followed by the wax tailings, until nothing but the coke remains in the still, which after cooling is removed with a pick and shovel. The paraffine distillate is treated in the same manner as described under the heading "Steam Distillation of Non-asphaltic and Mixed-base Petroleums."

The following average yields are obtained:

	Non-asphaltic Petroleum.	Mixed-base Petroleum.
Crude light naphtha.....	5 - 8%	6-8%
Crude heavy naphtha.....	7 -10%	13-15%
Crude kerosene.....	40 -45%	16-18%
Cracked distillate.....	25 -30%	20-25%
Residuum.....	10 -12%	40-50%
Loss.....	5 - 6%	4- 5%
<i>Upon distillation of the residuum:</i>		
Paraffine distillate.....	8½- 9½ parts	35-42 parts
Wax tailings.....	½ part	1- 2 parts
Coke.....	1 - 2 parts	4- 6 parts

The following represent the more important products obtained:

Gasolines and naphthas corresponding with those obtained from the steam distillation process. In addition, there are obtained a series of heavy naphthas ranging in gravity from 56–50° Baumé, used in the paint and varnish trades and for dry cleaning purposes, likewise a naphtha of 48–50° Baumé used by varnish manufacturers as a "turpentine substitute."

Kerosenes varying from 52–36° Baumé.

Gas or fuel oils varying from 40–28° Baumé. The gas oils derived from mixed-base petroleums have a gravity of 34–36° Baumé.

Lubricating oils similar to those obtained from the steam distillation process. Residuum ranging from 35–18° Baumé. The residuum obtained from non-asphaltic petroleum varies from 21–22° Baumé, and is used for laying dust ("road oils") and for fluxing harder asphalts.

Paraffine wax of the same grades as obtained from the steam distillation process.

We will now take up the asphalts derived from petroleum, which may be classified into four groups, viz.: residual oils, blown asphalts, residual asphalts and sludge asphalts.

RESIDUAL OILS

These are obtained in the following manner,¹ viz.:

- (1) The dry distillation of non-asphaltic petroleum.
- (2) The dry or steam distillation of mixed-base petroleum.
- (3) The steam distillation of asphaltic petroleum.

They are characterized by being liquid to semi-liquid at room temperature (77° F.), having a fusing-point of less than 80° F. (K. and S. method).

The characteristics of the residual oil depend upon three factors, viz.:

- (1) The nature of the petroleum from which they are produced.
- (2) The extent to which the distillation has been carried. The smaller the amount of volatile constituents removed, the more liquid will be the residual oil.
- (3) The care with which they have been prepared.

¹ "Bituminous Materials for Use in and on Road Surfaces, and Means of Determining their Character," by Clifford Richardson, *Proc. Am. Soc. Testing Materials*, **9**, 580, 1909; "The Modern Asphalt Pavement," by Clifford Richardson, New York, 1908; "Characteristics and Differentiation of Native Bitumens and their Residuals," by Clifford Richardson, *Eng. Record*, **67**, 466, 1913; "Laboratory Manual of Bituminous Materials," by Prévost Hubbard, 1st edition, pp. 123–127, 1916.

The character of the petroleum from which the residual oil has been produced is indicated by the percentage of solid paraffines contained in the residual oil and its specific gravity at 77° F., viz.:

	Specific Gravity at 77° F. (Test 7).	Solid Paraffines (Test 33)
Residual oils from non-asphaltic petroleum.....	0.85-0.95	4.0- 15.0%
Residual oils from mixed-base petroleum.....	0.90-1.00	Trace- 5.0%
Residual oils from asphaltic petroleum.....	0.95-1.02	0.0- 0.25%

Residual oils derived from petroleum composed principally of paraffinaceous hydrocarbons have the following disadvantages when used as fluxes:

(1) They are apt to show a separation of solid paraffinaceous hydrocarbons at low temperatures, giving the oil a gritty appearance.

(2) They do not flux with the hard asphalts and asphaltites as readily as the residual oils derived from petroleum containing a substantial amount of aromatic hydrocarbons. It should be noted that the residual oils derived from asphaltic petroleum constitute the best residual fluxes.

(3) They are apt to show a separation of greasy matter (paraffine or vaseline-like bodies) after having been fluxed with hard asphalts (Test 3).

Residual oils from non-asphaltic petroleum are not produced in large quantities to-day, as this character of petroleum is generally distilled to recover the lubricating oils and paraffine wax (see "Treatment of Residuum" in the dry distillation of non-asphaltic petroleum, p. 282).

Residual oils from mixed-base petroleum may be divided into two classes, namely, those derived from mixed-base petroleum produced in the United States, and those derived from Mexican petroleum. The latter may be differentiated by a higher percentage of fixed carbon (about 10 per cent vs. less than 5 per cent in the United States product), a smaller percentage of saturated hydrocarbons (less than 50 per cent vs. greater than 50 per cent in the United States product), a larger percentage of sulphur (greater than 4 per cent vs. less than 2 per cent in the United States product) and a lesser solubility in 88° naphtha (about 80 per cent vs. greater than 90 per cent in the United States product).

Residual oils derived from asphaltic petroleum may be divided into two classes, viz. those obtained from Trinidad petroleum, and those from United States asphaltic petroleum. The former is differentiated by a larger percentage of sulphur (greater than 2 per cent vs. less than 2 per cent in the United States product).

Another important criterion in arriving at the value of residual

oil for certain purposes is the percentage of volatile constituents. The greater the percentage of volatile matter, the less durable it will be upon exposure to the weather. This is important when the residual oil is used to flux harder asphalts and asphaltites, in which event it is desirable that the volatile constituents shall not exceed 5 per cent at 500° F. in four hours (Test 16). Residual oils of this character will withstand exposure to the weather remarkably well, either when used alone or in various combinations (as fluxes), and very much better than any of the tars. They are not as efficient in this respect, however, as the soft (non-volatile) fatty-acid pitches and vegetable and animal oils and fats.

Residual oils in general comply with the following characteristics:

(Test 1)	Color in mass.....	Brownish black to black
(Test 2a)	Homogeneity to the eye at room temperature.....	Uniform to gritty
(Test 2b)	Homogeneity under the microscope.....	Uniform to lumpy
(Test 3)	Appearance surface aged indoors.....	Variable
(Test 7)	Specific gravity at 77° F.....	0.85-1.05
(Test 8)	Viscosity.....	Variable
(Test 9c)	Consistency at 77° F.....	0-7
(Test 10)	Ductility.....	Variable
(Test 13)	Odor on heating.....	Oily
(Test 15a)	Fusing-point (K. and S. method).....	0-80° F.
(Test 15b)	Fusing-point (B. and R. method).....	10-98° F.
(Test 16)	Volatile matter.....	Variable
(Test 17a)	Flash-point.....	300-550° F.
(Test 18)	Burning-point.....	350-650° F.
(Test 19)	Fixed carbon.....	2-10%
(Test 21a)	Solubility in carbon disulphide.....	98-100%
(Test 21b)	Non-mineral matter insoluble.....	0-½%
(Test 21c)	Mineral matter.....	0-½%
(Test 22)	Carbenes.....	0-1%
(Test 23)	Solubility in 88° naphtha.....	80-99%
(Test 24)	Solubility in other solvents.....	Soluble in benzol and turpentine and partly soluble in alcohol and acetone
(Test 25)	Water.....	0-Tr.
(Test 28)	Sulphur.....	Tr.- 5%
(Test 30)	Oxygen.....	0- 3%
(Test 33)	Paraffine.....	0-15%
(Test 34)	Saturated hydrocarbons.....	30-90%
(Test 35)	Sulphonation residue.....	90-100%
(Test 37)	Saponifiable constituents.....	Tr.- 5%
(Test 40)	Glycerol.....	Absent
(Test 41)	Diazo reaction.....	No
(Test 42)	Antraquinone reaction.....	No

Table XXIV includes a few of the author's tests on typical residual oils.

Residual oils are so soft and liquid that it is impossible to ascertain their hardness by the needle penetrometer (Test 9b) or their fusing point by the cube method (Test 15c). The consistometer (Test 9c) and the viscosity test (Test 8a, b, c, d, e and f) are accordingly used for recording their liquidity, and and Kramer-Sarnow or the ball and ring methods for determining their fusing point.

For a description of "road oils," see pp. 353-360.

TABLE XXIV.—CHARACTERISTICS OF TYPICAL RESIDUAL OILS

No.	Test.	FROM NON-ASPHALTIC PETROLEUM.		FROM MIXED-BASE PETROLEUM.												FROM ASPHALTIC PETROLEUM.						
		Appalachian.	Ohio-Ind.	Mid-Continental.												Illinois.			California.			Trin.
				S.D.	B.	S.D.	B.	S.D.	B.	S.D.	B.	S.D.	B.	S.D.	B.	S.D.	B.	S.D.	B.	S.D.	B.	
<i>Physical Characteristics:</i>																						
3	Appearance surface aged 7 days.....	D.	D.	0.900	0.925	0.968	0.910	0.925	0.935	0.950	0.960	0.985	0.995	0.985	0.925	0.950	0.987	0.965	0.975	0.978	1.000	
7	Specific gravity at 77° F.....	0.0	0.0	0.0	0.0	0.0	0.0	0.0	0.0	0.0	0.0	0.0	0.0	0.0	0.0	0.0	0.0	0.0	0.0	0.0	0.0	
9c	Consistency at 77° F.....	2.9	2.9	1.2	1.3	2.7	3.0	3.4	3.4	4.7	4.9	5.2	4.5	0.0	0.0	6.2	0.0	0.0	1.1	0.0	0.0	
	Consistency at 32° F.....	1.2	1.2	1.3	1.3	2.7	3.0	3.4	3.4	4.7	4.9	5.2	4.5	0.0	0.0	25.2	0.0	2.7	6.5	5.4	5.4	
<i>Heat Tests:</i>																						
15a	Fusing-pt., deg. F., (K. & S method).	37	43	20	25	32	40	45	50	53	58	65	58	35	45	75	30	61	65	55		
15b	Fusing-pt., deg. F., (B. & R. method)	45	54.5	29	35	40.5	52	58	60	61	69	82	69	43.5	55	90	38.5	70	76	64		
16	Flash-point, 500° F. in 4 hrs., percent.....	7.8	5.1	10.35	4.5	3.5	3.0	1.36	2.8	2.1	12.25	3.9	7.3	1.36	15.9	14.4	18.1	7.3	4.1	4.1		
17a	Flash-point, deg. F.....	425	462	412	515	505	520	516	492	495	415	502	415	516	380	310	385	488	480	480		
19	Fixed carbon, per cent.....	2.3	4.2	4.2	2.6	4.8	4.45	3.65	3.7	3.8	4.8	4.35	2.9	3.65	10.9	4.53	7.8	6.7	9.8	9.8		
<i>Solubility Tests:</i>																						
21a	Soluble in carbon disulphide.....	100.0	99.9	99.84	99.9	99.9	99.9	99.9	99.9	99.9	99.8	99.8	99.8	99.9	99.9	99.6	99.8	99.6	99.65	99.75		
21b	Non-mineral matter insoluble.....	0.0	0.1	0.10	0.1	0.1	0.1	0.1	0.1	0.1	0.2	0.2	0.2	0.1	0.1	0.4	0.2	0.4	0.30	0.20		
21c	Mineral matter.....	0.0	0.0	0.06	0.0	0.0	0.0	0.0	0.0	0.0	0.0	0.0	0.0	0.0	0.0	0.0	0.0	0.0	0.05	0.05		
23	Soluble in 88° naphtha.....	98.6	97.1	99.1	98.8	96.5	98.2	97.9	96.9	92.6	90.8	91.7	94.3	97.9	82.2	92.7	88.1	84.8	85.3	85.3		
<i>Chemical Tests:</i>																						
28	Sulphur.....	0.0	0.8	0.6	0.6	4.8	1.5	...	1.8	2.9		
33	Paraffine.....	10.9	7.2	3.53	0.3	0.55	0.3	0.78	0.9	1.2	0.7	1.1	1.6	0.78	0.1	0.2	0.0	0.1	0.0	0.0		
34	Saturated hydrocarbons.....	85.0	76.2	...	52.3	...	70.0	...	53.0	68.7	63.2	...	74.6	...	36.3	30.5	36.4	36.4		
35	Sulphonation residue.....	98.2	96.0	97.5	95.7	98.0	...	98.4	96.6	95.8	95.8		

D=Dull; S. D.=Slightly Dull; B=Bright.

BLOWN PETROLEUM ASPHALTS

These are manufactured from residual oils derived from asphaltic, mixed-base or non-asphaltic petroleums, by blowing with air at elevated temperatures.

It has been recognized for many years that petroleum products become changed in their physical properties by treating with oxidizing agents or air. One of the first to report this was Gesner in 1865,¹ who remarked that

“Organic substances are oxidized by the atmosphere, and its action promoted by a high temperature. Hot air has therefore been forced through hydrocarbon oil during the process of purification, and in some instances with advantage.”

In 1876 W. P. Jenney patented the process of treating sludge oil obtained in refining petroleum with sulphuric acid, with a current of air at a temperature of 250° C.² He observed that a resinous substance was produced by the absorption of atmospheric oxygen by the oil.

De Smedt patented a process for oxidizing coal tar with potassium permanganate or permanganic acid at a temperature of 300° F.,³ also the method of oxidizing petroleum residues in a similar manner.⁴

The first to manufacture blown asphalt on a commercial scale was F. X. Byerley, who obtained a patent in 1894⁵ for blowing air through petroleum residues (and specifically those derived from Lima, Ohio crude oil), at temperatures between 400 and 600° F. In this way he obtained “pitches” of variable properties depending upon the temperature and the duration of the blowing process. For the softer grades (fusing under 200° F.), the Lima residuum was blown three days at 400° F., during which 2 per cent of distillate was produced. For the harder grades (fusing at about 400° F.) the residuum was blown four to five days at 500° F., during which between 5 and 6 per cent of distillate was recovered. The product was claimed to be resistant to changes in atmospheric temperature, and to differ from the corresponding steam-distilled asphalt by being readily soluble in petroleum benzine or naphtha. Byerley marketed the product under the name of “byerlite.” (See p. 18.) Air under a pressure of from 6 to 7 lb. per square inch was passed through a 6000-gal. still of the oil at the rate of 450 cu.ft. per minute. Ohio petroleum residue of 21

¹ “A Practical Treatise on Coal, Petroleum and Other Distilled Oils,” 2d Edition, 1865, p. 128.

² U. S. Pats. 178,061 and 178,154, both of May 30, 1876.

³ U. S. Pat. 236,995 of Jan. 25, 1881 to E. J. De Smedt.

⁴ U. S. Pats. 237,662 of Feb. 8, 1881, and 239,466 of Mar. 29, 1881 to E. J. De Smedt; also Eng. Pat. of Feb. 28, 1881, No. 849 to J. H. Johnson.

⁵ U. S. Pat. 524,130, Aug. 7, 1894.

to 27° Baumé and Texas petroleum residue of 12 to 15° Baumé were first used for the purpose.¹

G. F. and G. C. K. Culmer obtained patents for a similar process,² according to which petroleum residues of about 18° Baumé mixed with refined Trinidad or other native asphalt, were heated to 193° C. and blown for forty hours. From 3000 to 6000 cu.ft. of air per hour were passed through a still containing 3½ tons of the residue. After a time the external source of heat was removed, since it was found that the temperature of the mass increased of its own accord, due to the chemical changes induced by the introduction of air. The oxidation progressed very rapidly at first, and then more slowly, as it approached the end of the treatment. The loss in weight varied between 5 and 20 per cent. The product was claimed to be less brittle in winter, and less liable to soften under summer heat than asphalts derived from petroleum by straight distillation processes.

J. A. Dubbs patented a process³ for treating petroleum residues to obtain asphalt, which consists in heating them to a temperature of 150 to 230° C. and blowing first with air alone, and then with air mixed with steam in varying proportions, depending upon the consistency of the product desired.

In the foregoing processes the apparatus is extremely simple, consisting essentially of a still as is used for distilling petroleum (Fig. 105), the air being introduced through a series of pipes at the bottom, so arranged as to direct it against the sides.

According to modern practice, either air alone or a mixture of air and steam are blown through the "topped petroleum," i.e., petroleum from which the gasoline, naphtha and illuminating oils have been removed by prior distillation, at 525 to 575° F. for ten to twenty hours, or until the residue attains the desired consistency. It is found unnecessary to use any of the metallic oxidizing agents described in the earlier patents. With Mid-continental residual oils, the loss varies between 10 and 20 per cent and with California residual oils between 25 and 35 per cent,⁴ depending upon the fusing-point of the blown product.

¹ Byerley vs. The Sun Co., Circuit Court of the U. S. for the Eastern Dist. of Pennsylvania, Oct. Session, 1908, No. 201. See also U. S. Pat. 634,818 of Oct. 10, 1899 to J. W. Hayward.

² U. S. Pats. 635,429 and 635,430 both of Oct. 24, 1899.

³ U. S. Pat. 1,057,227 of Mar. 25, 1913.

⁴ In this case the distillate consists of a reddish oil about 21° Baumé, which on redistillation yields:

Naphtha (45° Bé.)	5%
Kerosene (35° Bé.)	10%
Gas oil (28° Bé.)	20%
Light lubricating oil (23° Bé.)	25%
Heavy lubricating oil (19° Bé.)	20%
Black residuum	15%
Loss	5%
Total	100%

Comparatively little is known regarding the exact chemical reactions which take place on blowing. Analysis shows that little oxygen actually combines with the asphalt.¹ It seems to be fairly well established that the effect of blowing is to eliminate hydrogen, which unites with the oxygen of the air, forming water. The process is also manifested by a condensing action, whereby the hydrocarbons polymerize, forming bodies of higher molecular weight and more complex structure.

Blown asphalts vary in consistency from semi-liquids to moderately hard solids at room temperature. They are marketed under various proprietary names such as Byerlite, Sarco, Hydrolene, Texaco, Parolite, Korite, Stanolite, S. O. Binders, Obispo, Ebano, etc.

The advantages of "blowing" over the steam distillation process are as follows:

(1) The yield of asphaltic residue from the blowing process is much greater than when steam distilled. In actual practice, with a topped asphaltic crude, the yield of blown asphalt varies between 75 and 90 per cent. Of the balance, 20 to 8 per cent is recovered as distillate, and 5 to 2 per cent represents loss.

(2) Blown petroleum asphalts are less susceptible to temperature changes than steam distilled products, and in addition acquire a certain amount of elasticity and resilience, usually termed "rubber-like properties." Comparing the respective asphalts of the same fusing-point and derived from the same crude, we find the blown product to be tougher, less brittle, softer in consistency and having a lower "susceptibility factor" (see p. 501) than the steam distilled product.

(3) In many cases it is possible by blowing to obtain a residue of better quality than if the steam distillation process were used, and in fact the blowing process renders many crude petroleum available which could not otherwise be used for preparing *high* fusing-point asphalts. Non-asphaltic petroleum will produce fairly good asphalts when blown, whereas the same crude will produce worthless residual asphalts by the steam distillation process. It is found that the more asphaltic the crude, the better the quality of the blown product, and the shorter the duration of the blowing process. Petroleum of mixed-base such as Mid-continental and certain of the Texas crudes, must be blown very much longer than pure asphaltic crudes, including the California and Trinidad.

(4) It is easier to control the "grade" of asphalt by blowing. As previously noted, the progress of blowing is more rapid at the start of the process than towards its conclusion. In other words, the residual asphalt

¹"Petroleum Analytical Methods," by S. P. Sadtler, 8th Intern. Cong. of Applied Chem., 25, 729-733, 1912.

is said to "come to grade" very slowly. With steam distillation, the alteration is much more marked at the end of the distillation process, so that the steam distilled asphalts "come to grade" very rapidly. In attempting therefore, to produce a residual asphalt of a definite fusing-point or

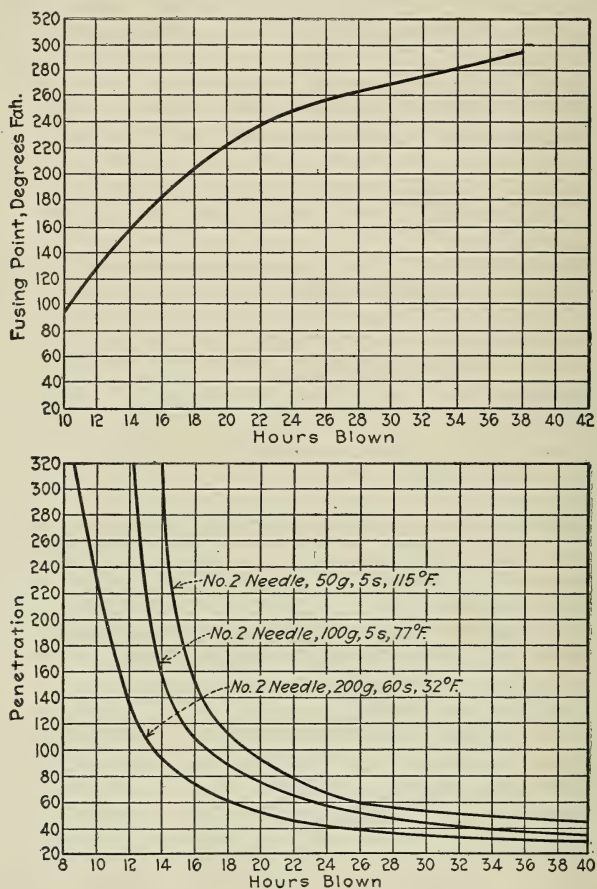

From "Good Roads."

FIG. 110.—Effect of Blowing on the Fusing-Point and Hardness of Petroleum Asphalt.

hardness, the blowing process is preferable, since it may be controlled to better advantage.

Fig. 110 shows the effect of prolonging the blowing process (at 425° F.) on the fusing-point (ball and ring method, Test 15b), and penetration (needle penetrometer-test 9b) of a topped mixed-base petroleum¹.

¹ "Value of Blown Asphalts and their Manufacture," H. B. Pullar, *Good Roads*, 3, 146, 1912.

Fig. 111 illustrates the consistency, tensile strength (multiplied by 10) and ductility curves of a typical blown petroleum asphalt produced from mid-continental petroleum, having a fusing-point of 127° F. (K. and S. method).

The care with which blown asphalts are prepared largely influences their physical characteristics. When made from improper crudes or by careless treatment, blown asphalts are apt to have certain defects, viz.:

(1) When made from non-asphaltic or mixed-base petroleums, they are likely to present a "greasy" surface, and especially on standing a few days, due to the partial separation of vaseline or paraffine-like bodies.

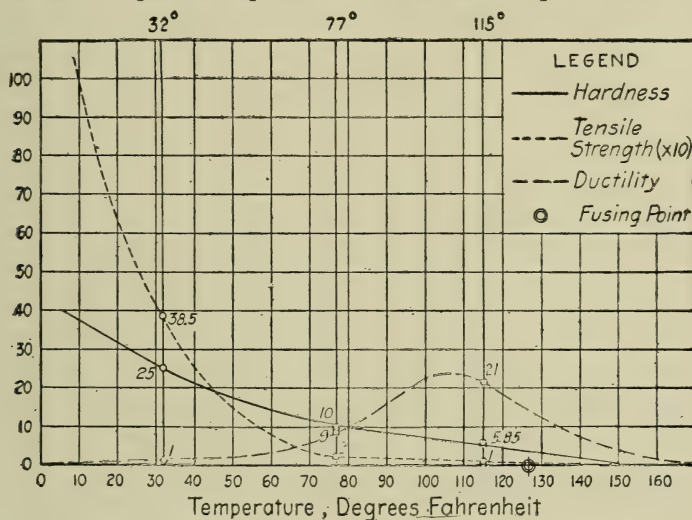

FIG. 111.—Chart of Physical Characteristics of Blown Petroleum Asphalt.

This will be considered more fully in Chapter XXVIII (p. 485). Blown asphalts made from *asphaltic* crudes do not behave in this manner.

(2) Blown asphalts, and especially those of high fusing-point, have the disadvantage of being "short," or in other words, they lack ductility. By carefully regulating the process, this defect may be minimized, particularly if the asphalt is subjected to a *moderate* amount of blowing. It is a fact, however, that the longer the blowing is continued, the less ductile will be the asphalt.

(3) Asphalts when over-blown, or blown at too high a temperature, show a separation of non-mineral matter insoluble in carbon disulphide, and a large percentage of carbenes. The former may readily be detected under the microscope (see Test 2b, p. 484), also in certain aggravated cases by the eye, by presenting a dull surface upon being disturbed (see Test 2a p. 484).

When the blown asphalts first appeared on the market, they unfortunately did not enjoy a good repute, but their quality has improved to such an extent that blown asphalts may now be procured of almost any fusing-point up to 300° F., which are not only more resistant to temperature changes, but are at the same time as ductile as any unblown product of the same "grade" (i.e., fusing-point or hardness at 77° F.)

In general, blown asphalts comply with the following characteristics:

(Test 1)	Color in mass.....	Black
(Test 2a)	Homogeneity to the eye at room temperature..	Uniform to gritty
(Test 2b)	Homogeneity under the microscope.....	Uniform to lumpy
(Test 3)	Appearance surface aged indoors one week....	Bright to dull and greasy
(Test 4)	Fracture.....	Soft grades do not show a fracture, hard grades present a conchoidal fracture
(Test 5)	Lustre.....	Bright to dull
(Test 6)	Streak on porcelain.....	Brownish black to black
(Test 7)	Specific gravity at 77° F.....	0.90-1.07..
(Test 9c)	Consistency at 77° F.....	2-30
(Test 9d)	Susceptibility factor.....	8-40
(Test 10)	Ductility.....	Variable
(Test 11)	Tensile strength.....	Variable
(Test 15a)	Fusing-point (K. & S. method).....	80-300° F.
(Test 15b)	Fusing-point (Ball and Ring method).....	100-325° F.
(Test 16)	Volatile matter, 500° F. in 4 hours.....	1-12%
(Test 17a)	Flash-point.....	350-550° F.
(Test 18)	Burning-point.....	400-650° F.
(Test 19)	Fixed carbon.....	5- 20%
(Test 21a)	Solubility in carbon disulphide.....	95-100%
(Test 21b)	Non-mineral matter insoluble.....	0- 5%
(Test 21c)	Mineral matter.....	0- ½%
(Test 22)	Carbenes.....	0-10%
(Test 23)	Solubility in 88° naphtha.....	50-90%
(Test 24)	Solubility in other solvents.....	Largely soluble in turpentine and benzol, and slightly soluble in alcohol and acetone.
(Test 25)	Water.....	Absent
(Test 28)	Sulphur.....	Tr.- 7.5%
(Test 30)	Oxygen.....	2- 5%
(Test 33)	Paraffine.....	0- 10%
(Test 34)	Saturated hydrocarbons.....	30- 75%
(Test 35)	Sulphonation residue.....	90-100%
(Test 37)	Saponifiable constituents.....	Tr.- 2%
(Test 40)	Glycerol.....	None
(Test 41)	Diazo reaction.....	No
(Test 42)	Antraquinone reaction.....	No

Fig. 112, plotted by the author from hundreds of determinations, shows the relation between the specific gravity and fusing-point of residual oils, blown asphalts and residual asphalts.

Residual oils range in specific gravity from 0.85 to 1.07 at 77° F., and in fusing-point (K. and S. method) from 0 to 80° F.; blown asphalts range in specific gravity from 0.90 to 1.05, and in fusing point from 80 to 300° F.; residual asphalts range in specific gravity from 1.00 to 1.17

and in fusing-point from 80 to 225° F. The chart shows that residual oils verge into the residual and blown asphalts respectively, and it also graphically illustrates the difference between the residual and blown asphalts. It will be observed that the effect of blowing is to increase the fusing-point and decrease the specific gravity of the product.

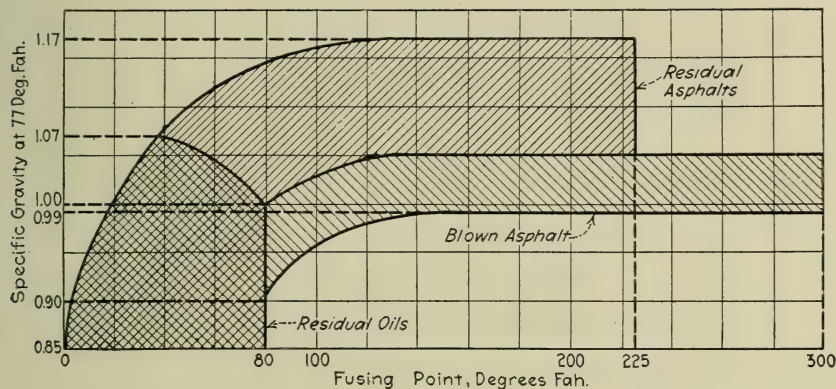

FIG. 112.—Relation between the Specific Gravity and Fusing-Point of Residual Oils, Blown Petroleum Asphalts and Residual Asphalts.

Another method for distinguishing between blown and residual asphalts, devised by the author, consists in finding their hardness by means of the consistometer (Test 9c) at a temperature *exactly 50° F. lower* than their fusing-point by the K. and S. method. Blown asphalts show a hardness of less than 15, whereas residual asphalts show a hardness greater than 15 under these conditions. This is illustrated by the following examples:

	Fusing-point, (Test 15a).	Hardness (Test 9c). at 50° F. below the Fusing-point.
<i>Blown petroleum asphalts:</i>		
Lima grade 120.....	91.5° F.	Hd. at 41.5° F. = 11.2
" " 250.....	155	Hd. at 105.0° F. = 10.1
" " 185.....	214	Hd. at 164.0° F. = 7.8
" " 285.....	271.5	Hd. at 221.5° F. = 6.7
Mid-continental grade 115..	100	Hd. at 50.0° F. = 11.9
" " 180..	164	Hd. at 114.0° F. = 10.3
" " 215..	215	Hd. at 165.0° F. = 8.4
<i>Residual asphalts:</i>		
California grade E.....	90	Hd. at 40.0° F. = 21.5
" " DE.....	108	Hd. at 58.0° F. = 22.2
" " D.....	124	Hd. at 74.0° F. = 22.2
" " C.....	146	Hd. at 96.0° F. = 22.9
" " CB.....	168.5	Hd. at 118.5° F. = 23.5
" " B.....	209	Hd. at 159.0° F. = 22.9
Mid-continental grade 140..	119.5	Hd. at 69.5° F. = 21.5
" " 180..	158	Hd. at 108.0° F. = 21.5

It is of interest to note in connection with the foregoing figures, that for any particular crude, the hardness at the "fusing-point less 50° F." decreases with the extent of the blowing, but remains practically constant in the case of the residual asphalts, regardless of the degree to which the distillation may have been carried.

Upon comparing a residual asphalt with a blown product of the same fusing-point, it will be found that the latter is considerably softer, as evidenced by its consistency or penetration. Conversely, upon comparing a residual asphalt with a blown product of the same hardness or penetration, the fusing-point of the latter will be found to be considerably higher. It is also interesting to note that blown asphalts are more soluble in 88° naphtha (and in other petroleum distillates) than unblown residual asphalts of the same fusing-point.

Blown asphalts, due to their greater softness, and correspondingly large proportion of "life-giving" constituents, are better weather-resistants than residual asphalts derived from the same crude, having the same fusing-point and showing the same proportion of volatile matter. They are about equal in weather-resistance to residual asphalts of the same hardness prepared from the same crude, and far superior to sludge asphalts regardless of their hardness or fusing-point. It is a mooted question whether the native asphalts or the blown asphalts excel in weather-resisting properties, and to which in the author's opinion no categorical answer can be given.¹

Table XXV includes the results obtained by the author upon examining representative blown asphalts derived from different crudes and blown to different extents.

SULPHURIZED ASPHALTS ²

Under the action of heat, sulphur has the same condensing effect on asphalt as oxygen. The sulphur eliminates hydrogen, in the form of gaseous hydrogen sulphide (H₂S). This reaction may be roughly represented as follows:

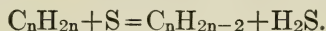

The process of treating asphalt with sulphur was first disclosed by A. G. Day,³ and subsequently by J. A. Dubbs,⁴ who heated Pennsyl-

¹ "The Modern Asphalt Pavement," loc. cit.; "Value of Blown Asphalts and Their Manufacture," by H. B. Pullar, *Good Roads*, **3**, 146-7, 1912; "American Petroleum Industry," loc. cit. 620-631.

² "The Effect of Sulphur on the Oxidation of Hydrocarbons, with Particular Reference to Asphalt," B. T. Brooks and I. W. Humphrey, *J. Ind. Eng. Chem.*, **9**, 746, 1917.

³ U. S. Pat. 58,615 of Oct. 9, 1866 to A. G. Day.

⁴ U. S. Pats. 468,867 of Feb. 16, 1892; 480,234 and 480,235, both of Aug. 2, 1892; also 608,372 of Aug. 2, 1898 to J. A. Dubbs.

PAHLTIC

o-Indiana

Homo.	Ho:
Non-hom.	Ho:
Dull	Bri
Conch.
Bright
Black	Bl:
1.015	1.
14.1	0.
21.5	7.
41.9	28.
14.6	22.
2	28.
1	93.
0.125	1
0.75	0.
2.7	1.
12.5	13.

190	126
209	144
2.1	1.
522	490
10.3	15.

99.22	98.
0.68	1.
0.10	0.
0.4	0.
70.5	84.

.....	7
.....	1
.....	45
.....	...

TABLE XXV.—CHARACTERISTICS OF TYPICAL BLOWN PETROLEUM ASPHALTS

No.	Test.	FROM NON-ASPHALTIC PETROLEUM.								FROM MIXED-BASE PETROLEUMS.												FROM ASPHALTIC PETROLEUM.										
		Ohio-Indiana.								Illinois.		Mid-Continental.						Mexico.						Gulf.		California.						
		Homo.	Homo.	Homo.	Homo.	Non-hom.	Non-hom.	Non-hom.	Non-hom.	Non-hom.	Non-hom.	Homo.	Homo.	Non-hom.	Non-hom.	Homo.	Homo.	Non-hom.	Non-hom.	Homo.	Homo.	Homo.	Homo.	Homo.	Homo.	Homo.	Homo.	Homo.	Homo.	Homo.	Homo.	
<i>Physical Characteristics:</i>																																
2a	Homogeneity to eye at 77° F.	Homo.	Homo.	Non-hom.	Non-hom.	Non-hom.	Non-hom.	Non-hom.	Non-hom.	Gritty	Gritty	Non-hom.	Non-hom.	Homo.	Homo.	Non-hom.	Non-hom.	Homo.	Homo.	Homo.	Homo.	Homo.	Homo.	Homo.	Homo.	Homo.	Homo.	Homo.	Homo.	Homo.	Homo.	
2b	Homogeneity under microscope.	Homo.	Homo.	Non-hom.	Non-hom.	Non-hom.	Non-hom.	Non-hom.	Non-hom.	Gritty	Gritty	Non-hom.	Non-hom.	Homo.	Homo.	Non-hom.	Non-hom.	Homo.	Homo.	Homo.	Homo.	Homo.	Homo.	Homo.	Homo.	Homo.	Homo.	Homo.	Homo.	Homo.	Homo.	
3	Appearance surface, aged 7 days.	Sl. dull	Sl. dull	Sl. dull	Dull	Dull	Dull	Dull	Dull	Bright	Bright	Bright	Bright	Bright	Bright	Bright	Bright	Bright	Bright	Bright	Bright	Bright	Bright	Bright	Bright	Bright	Bright	Bright	Bright	Bright	Bright	
4	Fracture.	Sl. dull	Sl. dull	Sl. dull	Conch.	Conch.	Conch.	Conch.	Conch.	Bright	Bright	Bright	Bright	Bright	Bright	Bright	Bright	Bright	Bright	Bright	Bright	Bright	Bright	Bright	Bright	Bright	Bright	Bright	Bright	Bright	Bright	
5	Lustre.	Bn. Bk.	Black	Black	Black	Black	Black	Black	Black	Bn. Bk.	Black	Black	Black	Black	Black	Black	Black	Black	Black	Black	Black	Black	Black	Black	Black	Black	Black	Black	Black	Black	Black	
6	Streak.	0.987	0.995	1.005	1.015	1.021	1.012	1.002	0.958	1.010	1.009	1.002	0.980	0.985	1.029	1.054	0.988	1.016	1.005	1.015	1.022	1.038	1.037	1.032	1.004	1.032	1.008	1.050	1.045	1.038	1.060	
7	Specific gravity at 77° F.	0.987	0.995	1.005	1.015	1.021	1.012	1.002	0.958	1.010	1.009	1.002	0.980	0.985	1.029	1.054	0.988	1.016	1.005	1.015	1.022	1.038	1.037	1.032	1.004	1.032	1.008	1.050	1.045	1.038	1.060	
8	Consistency at 115° F.	1.5	5.85	9.8	14.1	18.3	18.7	19.6	2.7	10.3	2.7	4.8	3.8	4.9	5.6	10.6	14.1	22.9	0.0	3.4	0.0	4.1	9.0	9.7	2.4	9.4	0.0	3.4	7.05	8.5	9.1	
9c	Consistency at 77° F.	4.8	10.0	17.5	21.5	26.7	28.0	29.6	4.3	14.6	5.5	6.7	8.1	11.4	15.7	18.8	18.2	28.3	4.3	4.9	7.6	22.9	22.9	25.2	7.7	17.4	6.9	12.6	22.2	25.2	26.6	
10	Consistency at 32° F.	15.9	25.0	31.7	41.9	49.3	51.9	58.5	16.9	28.0	23.5	24.2	29.4	24.1	32.1	38.0	33.3	62.1	21.2	21.5	28.4	50.7	61.3	57.5	26.7	34.2	30.7	47.9	50.7	65.4	70.5	
9d	Susceptibility factor.	15.7	15.1	14.8	14.6	14.5	14.5	14.4	14.8	10.8	21.2	18.0	22.3	15.7	20.0	17.7	8.9	15.6	23.7	15.9	22.5	31.5	34.4	29.0	23.4	18.2	33.6	32.5	29.6	36.7	32.1	
10b	Ductility in cms. at 115° F.	0.5	21	3	2	1	0.75	0.25	17.5	2	21.5	28	27	5.5	25	2	1	0.5	14	16	28.5	60	14	17.5	21	9	10	35	28	21	22	
11	Ductility in cms. at 77° F.	29.5	9	2.5	1	0.5	0.5	0.125	56	1.5	87.0	51	88	2.5	2	1.5	0.5	0.25	50	13	93.5	20	1	2.5	56	3	54.5	40	23	0.5	0.3	
11	Ductility in cms. at 32° F.	3.5	1	0.25	0.125	0.0	0.0	0.0	6.5	0.5	2.0	0.75	0.75	1.5	1	0.75	0.125	0.0	0.75	4	1	0.25	0	0	1	1	1.5	0.5	0	0	0	
11	Tensile strength in kg. at 115° F.	0.05	0.10	0.50	0.75	1.80	2.70	3.75	0.0	0.50	0.05	0.15	0.1	0.1	0.35	0.95	0.75	0.60	0.1	0.1	0.2	0.75	1.0	1.1	0.15	0.35	0.0	0.6	1.2	1.15	1.8	
11	Tensile strength in kg. at 77° F.	0.1	0.2	1.5	2.7	4.7	6.2	5.25	0.3	1.65	0.95	0.5	0.7	1.1	2.15	3.15	3.20	2.75	0.5	0.45	1.0	5.0	5.6	5.4	0.4	4.5	0.3	2.30	4.8	6.4	6.1	
11	Tensile strength in kg. at 32° F.	2.9	3.85	10.5	12.5	14.0	13.0	10.0	6.25	7.2	22.5	10.0	12.0	6.25	10.6	12.6	8.0	7.50	8.0	3.15	13.5	18.5	12.5	14.5	6.35	4.0	7.0	10.8	12.0	6.25	16.0	
<i>Heat Tests:</i>																																
15a	Fusing-point, deg. F., by K. & S. method.	91.5	127	155	190	214	238	271.5	95	164	98	108	115	122.5	132	154	215	251	89.5	104	126	143	152	165	104	136	91.5	137	147	155	178	
15b	Fusing-point, deg. F., by B. & R. method.	106	144	174.5	209	234.5	259	294	110	181	108	124	135	144	150	171.5	236	272	110	126	144	161	183	182	116	157	106.5	155	162	165	180.5	
16	Volatile, 500° F. in 4 hrs., per cent.	4.65	3.25	2.70	2.1	1.6	1.9	2.0	3.4	1.28	3.0	2.11	2.99	1.02	2.41	2.17	0.65	0.48	2.36	4.99	1.35	1.1	0.93	1.0	2.65	1.87	12.0	14.8	11.2	3.94	10.4	
17a	Flash-point, deg. F.	480	510	515	522	520	525	522	500	535	470	494	480	510	420	485	525	485	385	375	490	475	480	505	440	450	365	452	460	460	473	
19	Fixed carbon, per cent.	8.4	9.1	9.6	10.3	11.8	12.5	15.7	7.8	10.0	8.6	9.3	9.9	9.1	12.7	15.3	11.4	12.3	12.8	15.9	15.2	15.7	17.0	18.0	10.2	10.8	9.7	11.0	12.4	18.0	13.2	
<i>Solubility Tests:</i>																																
21a	Soluble in carbon disulphide.	99.86	99.69	99.43	99.22	99.13	98.67	97.58	98.75	99.20	99.60	99.08	99.83	98.45	99.25	99.28	98.93	98.30	99.80	99.83	98.80	99.05	99.50	98.70	99.50	99.22	99.78	99.60	99.25	98.68	99.25	
21b	Non-mineral matter insoluble.	0.06	0.20	0.45	0.68	0.72	1.15	2.20	1.10	0.62	0.03	0.50	0.07	0.46	0.70	0.55	0.85	1.42	0.12	0.06	1.00	0.80	0.28	1.25	0.38	0.66	0.13	0.18	0.60	1.00	0.55	
21c	Mineral matter.	0.08	0.11	0.12	0.10	0.15	0.18	0.22	0.15	0.18	0.37	0.12	0.10	0.09	0.05	0.17	0.22	0.28	0.08	0.11	0.20	0.15	0.22	0.05	0.12	0.09	0.22	0.15	0.32	0.20	0.13	
22	Carbens.	0.0	0.0	0.1	0.4	1.25	3.4	7.8	0.0	0.5	0.0	0.1	0.0	0.0	0.2	0.3	2.1	3.8	0.0	0.0	0.1	0.1	0.2	0.3	0.1	0.0	0.0	0.1	0.2	0.0	0.3	
23	Soluble in 88° naphtha.	88.5	82.0	72.8	70.5	67.7	61.9	53.6	85.2	76.5	86.5	85.1	81.8	80.8	76.2	70.1	68.0	60.8	88.0	80.2	84.0	82.2	78.3	73.4	79.9	80.7	78.0	71.8	72.0	73.8	68.7	
<i>Chemical Tests:</i>																																
28	Sulphur.	0.45		0.3		0.6		0.5	0.3	0.5	0.25						1.2		0.7	5.7	6.2	7.0	5.6		0.4	0.9	1.3				1.1	
33	Paraffine.	9.5		7.3		6.1		4.8	5.8	4.9	6.1	5.4				0.8	4.3	3.2	2.2	1.7	1.2	1.0		0.1	1.4	0.2				0.0		
34	Saturated hydrocarbons.	65.2		68.0		72.5		74.7	31.7	56.1	52.6					51.3	66.0	68.8	48.9	54.7	45.1			43.2	47.2	32.0				38.2		
35	Sulphonation residue.	96.0				95.5													92.5						98.0	95.0					93.0	

To face page 294.

vania, Lima and Ohio residuums with 20 to 25 per cent of sulphur, at a temperature somewhat below the boiling-point of sulphur, until the evolution of gas ceased. The resulting product is very similar in its physical properties to oxidized asphalt, being only slightly susceptible to temperature changes, but it is still further lacking in ductility. Twenty years ago, asphalt treated in this manner was exploited under the name "Pittsburg Flux." This was before blown asphalts appeared on the market, which on account of their smaller cost of production, soon displaced the sulphurized product. Other processes for vulcanizing asphalts were described by Peck.¹ Callender vulcanized a mixture of Trinidad asphalt and fatty-acid pitch,² and William Griscom worked out a process along similar lines, producing a rubber-like substance by vulcanizing a mixture of fatty-acid pitch and asphalt.³ Mixtures of Grahamite and vegetable oils,⁴ coal tar pitch,⁵ sludge asphalt,⁶ and wool-fat pitch⁷ have also been vulcanized with sulphur to increase their elasticity and decrease their susceptibility to temperature changes.

RESIDUAL ASPHALTS

As stated previously, these are derived from the steam distillation of mixed base or asphaltic petroleums. Non-asphaltic petroleums are unsuitable for manufacturing residual asphalts. The distillation is continued until the residual asphalt reaches the desired "grade." The temperature of the residue in the still is carefully observed, and under no circumstances allowed to exceed 650 to 700° F., otherwise excessive decomposition and cracking of the hydrocarbons will take place, and result in the production of an inferior product. This is especially liable to be the case if a residual asphalt of hard consistency and high fusing-point is to be produced. Mexican petroleums are very susceptible to overheating, and great care must be taken not to allow the residue in the still to exceed a temperature of 560° F. In the early days of the industry, the residual asphalts were carelessly manufactured, without suitable temperature control, and as a result they soon fell into disrepute.

At the present time, residual asphalts are being marketed of excellent quality, including products fusing as high as 225° F., with a hardness in the

¹ U. S. Pats. 624,081 and 624,082 of May 2, 1899 to D. W. Peck.

² Eng. Pat. of Oct. 11, 1881, No. 4408 to W. O. Callender.

³ U. S. Pats. 529,727, 529,728, 529,729 and 529,730, dated Nov. 27, 1894 to William Griscom.

⁴ U. S. Pat. 210,405 of Dec. 3, 1878 to A. G. Day.

⁵ U. S. Pats. 403,548 of May 21, 1889 to B. E. Olsen and Chas. Gabriel; 598,147 of Feb. 1, 1898 to Albert Hannemann.

⁶ U. S. Pat. 651,358 of June 12, 1900 to J. A. Just.

⁷ Ger. Pat. 225,911 of May 25, 1907 to A. F. Malchow.

neighborhood of 100 on the consistometer scale (Test 9c), but this is due solely to the better methods of control. Other things being equal, it is not as easy to produce a residual asphalt as a blown product of a given high fusing-point.

Lester Kirschbraun devised a process¹ for removing undesirable constituents of a paraffine- or vaseline-like character from residual asphalts (12 to 24° Baumé) derived from a mixed-base petroleum, by introducing large quantities of low-pressure steam superheated to 600 to 700° F., through a charge of the asphalt heated in a still to 450 to 700° F. It is claimed that these heavy paraffine- or vaseline-like hydrocarbons are non-cementitious, non-ductile, non-adhesive and greasy in character, and in addition, impart these undesirable characteristics to the asphaltic hydrocarbons when mixed with the latter. Kirschbraun's product is supposed to have an unusual degree of ductility, in many cases capable of being elongated more than 100 times its cross-section at 77° F., also a high degree of adhesiveness and cementitiousness not found in residual asphalts distilled with saturated steam, or in blown asphalts prepared in the usual manner.

Carelessly prepared residual asphalts may be detected by:

(1) Lack of homogeneity (Test 2). This may be due either to overheating or because the distillation has been continued too far.

(2) The surface of the material assuming a "greasy" appearance on aging. This is due to the use of crudes containing too large a proportion of paraffine- or vaseline-like hydrocarbons, which have not been removed during the distillation process.

(3) The presence of too large a percentage of volatile matter (Test 16) or too low a flash-point (Test 17), due to the distillation not having been carried far enough, or at a temperature sufficiently high to remove the low-boiling point constituents.

(4) A large percentage of non-mineral matter insoluble in carbon disulphide ("free carbon") (Test 21b). This is due either to overheating or to the distillation having been carried too far. Carefully prepared residual asphalts should not contain more than 5 per cent.

(5) The presence of carbenes (Test 22), which are produced by overheating. Carefully prepared residual asphalts should not contain more than 2 per cent.

Residual asphalts made from mixed-base petroleum are not as susceptible to overheating as those derived from purely asphaltic petroleum. In both cases the percentage of asphalt recovered in the distillation process is *greater* than that contained in the original petroleum, due to the fact that the heavy lubricating oils are *polymerized or condensed* under the in-

¹ U. S. Pat. 1,194,750, Aug. 15, 1916, to Lester Kirschbraun.

fluence of heat into substances resembling asphalt. In a purely asphaltic petroleum, the quantity of residual asphalt formed during the distillation process is proportionately *less* than in the case of mixed-base petroleum, but the residual asphalt in the former case will not show a greasy surface on aging, no matter how carelessly it may have been distilled.

Residual asphalts in general comply with the following characteristics:

(Test 1)	Color in mass.....	Black
(Test 2)	Homogeneity.....	Variable
(Test 3)	Appearance surface aged indoors 1 week..	Variable
(Test 4)	Fracture.....	Conchoidal in the case of hard residual asphalts.
(Test 5)	Lustre.....	Variable
(Test 6)	Streak on porcelain.....	Black
(Test 7)	Specific gravity at 77° F.....	1.00-1.17
(Test 9b)	Penetration at 77° F.....	150-0
(Test 9c)	Consistency at 77° F.....	5-100
(Test 9d)	Susceptibility factor.....	40-60
(Test 10)	Ductility at 77° F.....	Variable
(Test 11)	Tensile strength at 77° F.....	0.5-10.0
(Test 13)	Odor on heating.....	Oily
(Test 14a)	Behavior on melting.....	Pass rapidly from the solid to the liquid state
(Test 15a)	Fusing-point (K. & S. method).....	80-225° F.
(Test 15b)	Fusing-point (B. & R. method).....	100-250° F.
(Test 16)	Volatile matter.....	Variable
(Test 17)	Flash-point.....	400-600° F.
(Test 18)	Burning-point.....	450-700° F.
(Test 19)	Fixed carbon.....	5-40%
(Test 21a)	Soluble in carbon disulphide.....	85-100%
(Test 21b)	Non-mineral matter insoluble.....	0-15%
(Test 21c)	Mineral matter.....	0-1%
(Test 22)	Carbenes.....	0-30%
(Test 23)	Solubility in 88° naphtha.....	25-85%
(Test 24)	Solubility in other solvents.....	Quite soluble in benzol and turpentine and scarcely soluble in alcohol and acetone
(Test 25)	Water.....	None
(Test 26)	Carbon.....	85-87%
(Test 27)	Hydrogen.....	9-13%
(Test 28)	Sulphur.....	Tr.-10%
(Test 29)	Nitrogen.....	Tr.-1.0%
(Test 30)	Oxygen.....	0-2½%
(Test 32)	Naphthalene.....	None
(Test 33)	Paraffine.....	0-5%
(Test 34)	Saturated hydrocarbons.....	25-75%
(Test 35)	Sulphonation residue.....	90-100%
(Test 37)	Saponifiable constituents.....	0-2%
(Test 41)	Diazo reaction.....	No
(Test 42)	Anthraquinone reaction.....	No

Residual asphalts are characterized by the following features:

(1) Their comparatively high specific gravity, serving to distinguish them from blown asphalts.

(2) Their greater hardness or consistency at 77° F. for a given fusing-point, which also distinguishes them from blown asphalts.

(3) The greater tensile strength at 77° F. for a given fusing-point, which similarly distinguishes them from blown asphalts.

(4) The fusing-point, which is lower, and serves to distinguish them from the asphaltites.

(5) The susceptibility factor, which is very much higher than blown asphalts. In the case of residual asphalts the susceptibility factor is greater than 40, whereas with blown asphalts it is less than 40.

(6) The volatile matter, which for a given fusing-point is lower than that contained in the crude native asphalts.

(7) The flash-point, which for a given fusing-point is higher than that of the crude native asphalts.

(8) The fixed carbon, which for a given fusing-point is greater than that of blown asphalts.

(9) The mineral matter, which runs well within 1 per cent and serves to distinguish residual asphalts from most of the native asphalts.

(10) Carbenes, when present in percentages in excess of 5, serve to distinguish them from native asphalts.

(11) Paraffine when present serves to distinguish residual asphalts from native asphalts, although this test is not infallible, for as pointed out previously, there are certain residual asphalts which do not contain paraffine (i. e., obtained from asphaltic petroleums).

(12) The saturated hydrocarbons will exceed 25 per cent in the case of residual and blown asphalts, whereas they will be less than 25 per cent in the case of native asphalts.¹ With asphaltites the saturated hydrocarbons amount to less than 10 per cent.

(13) A greater percentage of sulphonation residue is derived from residual and blown asphalts than from the various pitches.

(14) A negative diazo reaction, which distinguishes residual asphalts from pitches derived from wood, peat, lignite, coal, shale and bones.

(15) The absence of the anthraquinone reaction, which distinguishes residual asphalts from the various pitches derived from coal.

(16) By the percentage of free asphaltous acids (Test 38a) which runs below 2½ per cent in residual asphalts and above 2½ per cent in the native asphalts. Similarly, the percentage of asphaltous-acid anhydrides (Test 38b) runs less than 1½ per cent in residual asphalts and greater than 1½ per cent in native asphalts.

There has been much discussion whether or not it is possible to distinguish between petroleum asphalts and native asphalts.² Various methods have been

¹ "Characteristics and Differentiation of Native Bitumens and their Residuals," by Clifford Richardson, *Eng. Record*, **67**, 466, 1913.

² "Distinction of Natural Asphalt Bitumen from Petroleum Pitch and Coal-tar Pitch," by Jenő Kovács and S. Söbét, *Chem. Rev. Fett-Harz-Ind.*, **7**, 8, 1900; "Detection of Adulterants

proposed for the purpose, but the only ones which seem to give dependable results are the percentages of saturated hydrocarbons (Test 34), free asphaltous acids (Test 38a) and asphaltous-acid anhydrides (Test 38b), referred to in items (12) and (16) above.

At the present time it is impossible to distinguish between blown asphalts, and combinations of asphaltites with residual oils or soft residual asphalts, since their respective properties are very much alike.

Residual asphalts obtained from California petroleum are customarily designated by letters to differentiate the different grades. The so-called "A" grade is extremely hard and brittle and grinds to a non-adherent powder between the teeth, ranging in penetration between 5 and 20 at 77° F. (No. 2 needle, 100 grams, 5 seconds). "B" grade is quite hard and brittle and grinds to an adherent powder between the teeth, ranging in penetration between 15 and 50 at 77° F. "C" grade chews with difficulty and ranges in penetration between 25 and 75 at 77° F. "D" grade chews readily without sticking to the teeth, and ranges in penetration from 45 to 150 at 77° F. "E" grade sticks to the teeth on chewing and shows a penetration greater than 200 at 77° F. "F" and "G" grades are in reality residual oils of high and low viscosities respectively. When carefully prepared, "B" grade does not contain more than 2 per cent of non-mineral matter insoluble in carbon disulphide, and the softer grades correspondingly less.¹

Fig. 113 shows the hardness, tensile strength (multiplied by 10) and ductility curves of a typical sample of "D" grade California residual asphalt fusing at 124° F. (K. and S. method).

Table XXVI includes the results obtained by the author on representative specimens of residual asphalts.

in Natural Asphaltum," by B. Malenkovic, *Oesterr. Chem. Zeit.*, **8**, 123, 1905; "Distinction between Natural and Petroleum Asphalts," by J. Marcusson and R. Eichmann, *Chem. Zeit.*, **32**, 965, 1908; "Identifying Asphalts," by J. Marcusson, *Chem. Rev. Fett-Harz-Ind.*, **18**, 47, 1911; "Petroleum Asphalts," by D. Lohmann, *Chem. Rev. Fett-Harz-Ind.*, **18**, 107, 1911; "Chemical Composition and Methods of Distinguishing Natural and Artificial Asphalts," by J. Marcusson, *Chem. Rev. Fett-Harz-Ind.*, **19**, 166, 1912; "Separation of Natural and Petroleum Asphalts," by J. Marcusson, *Chem. Zeit.*, **36**, 801, 1912; Richardson's "Modern Asphalt Pavement," loc. cit., p. 276; "Quantitative Determination of Natural Asphaltum in the Presence of Artificial Asphaltum," by J. Marcusson, *Z. angew. Chem.*, **26**, 91, 1913; "Detection of Natural Asphalt and Petroleum Pitch," by F. Schwarz, *Chem. Rev. Fett-Harz-Ind.*, **20**, 28, 1913; "Analysis of Petroleum Oil and Mineral Wax," by H. Kantorowicz, *Chem. Zeit.*, **37**, 1394, 1438, 1565, and 1594, 1913; "Differentiation of Natural and Artificial Asphalts," by J. Marcusson, *Mitt. k. Materialprüf.* **32**, 419, 1914; "Differentiation of Natural and Oil Asphalts," by E. C. Pailler, *J. Ind. Eng. Chem.*, **6**, 286, 1914; "Chemistry and Analysis of Asphaltum," by J. Marcusson, *Chem. Zeit.*, **38**, 813 and 822, 1914; "Chemical Composition of Natural Asphalts," by J. Marcusson, *Z. angew. Chem.*, **29**, 346 and 349, 1916.

¹"The California Asphaltum Industry," by F. H. Minard, *Eng. Mining J.*, 503, 1903; "Production and Use of Petroleum in California," Bulletin No. 32, California State Mining Bureau, San Francisco, Cal., Mar., 1904.

TABLE XXVI.—CHARACTERISTICS OF

No.	Test.	FROM MIXED-BASE PETRO						
		Mid-continental (Texas).						
<i>Physical Characteristics</i>								
2a	Homogeneity to eye at 77° F.	Homo.	Homo.	Homo.	Homo.	Homo.	Homo.	Non-ho.
2b	Homogeneity under microscope.	Homo.	Homo.	Homo.	Homo.	Homo.	Gritty	Lumpy
3	Appearance surface aged 7 days.	Dull	Dull	Dull	Dull	Dull	Dull	Dull
4	Fracture.	Conch.	Conch.	Conch.	Conch.	Conch.	Conch.
5	Lustre.	Bright	Bright	Bright	Bright	Sl. Dull	Sl. Dull
6	Streak.	Bn. Bk.	Black	Black	Black	Black	Black	Black
7	Specific gravity at 77° F.	1.032	1.050	1.078	1.095	1.119	1.138	1.145
9c	Consistency at 115° F.	1.6	5.1	9.6	14.6	27.1	40.2	47.9
	Consistency at 77° F.	7.2	15.2	23.5	42.2	58.5	76.1	88.8
	Consistency at 32° F.	45.2	66.9	81.4	92.8	107.0	>100	>100
9d	Susceptibility factor.	44.8	51.7	50.5	49.5	48.0	>45	>45
10b	Ductility in cm. at 115° F.	14.5	37	64.5	22	12	0	0
	Ductility in cm. at 77° F.	55	19	10	2.5	0	0	0
	Ductility in cm. at 32° F.	0	0	0	0	0	0	0
11	Tensile strength in kg. at 115° F.	0.05	0.10	0.35	1.10	2.00	4.50	5.50
	Tensile strength in kg. at 77° F.	1.0	2.7	4.2	7.0	6.0	4.5	4.0
	Tensile strength in kg. at 32° F.	6.0	15.0	9.5	8.5	7.0	5.5	5.0
<i>Heat Tests</i>								
15a	Fusing-point, deg. F., by K. and S. method.	97.5	119.5	142	158	167	194	205
15b	Fusing-point, deg. F., by B. and R. method.	115	131.5	159	170	184	213	227
16	Volatile, 500° F., in 4 hrs., per cent.	0.92	0.78	0.50	0.78	1.00	0.89	0.71
17a	Flash-point, deg. F.	508	525	532	545	575	590	595
19	Fixed carbon, per cent.	8.1	13.8	18.5	22.7	23.1	27.2	33.3
<i>Solubility Tests</i>								
21a	Soluble in carbon disulphide.	99.56	99.25	99.03	98.60	96.45	94.07	91.02
21b	Non mineral-matter insoluble.	0.22	0.50	0.70	1.08	3.12	5.31	8.20
21c	Mineral matter.	0.22	0.25	0.27	0.32	0.43	0.62	0.78
22	Carbenes.	0.8	1.8	3.0	3.7	5.0	6.1	12.3
23	Soluble in 88° naphtha.	86.1	82.5	80.3	77.0	72.3	64.7	61.0
<i>Chemical Tests</i>								
28	Sulphur.	1.2	0.95	1.3	0.6
33	Paraffine.	1.4	1.3	1.25	1.0	0.8	0.7	0.5
34	Saturated hydrocarbons.	42.0	60.7	70.1
35	Sulphonation residue.	95.0

Residual asphalts obtained from the Texan mixed-base petroleum are characterized by the presence of paraffine, less than $1\frac{1}{2}$ per cent of sulphur and between 40 and 70 per cent of saturated hydrocarbons; those obtained from California asphaltic petroleum are practically free from paraffine, contain less than $1\frac{1}{2}$ per cent of sulphur, and between 25 and 40 per cent of saturated hydrocarbons; those derived from Mexican mixed-base

TYPICAL RESIDUAL ASPHALTS

LEUM.			FROM ASPHALTIC PETROLEUM.								
Mexican.			California.						Trinidad.		
Homo.	Homo.	Homo.	Homo.	Homo.	Homo.	Homo.	Homo.	Homo.	Non-ho.	Homo.	Homo.
Gritty	Homo.	Gritty	Homo.	Homo.	Homo.	Homo.	Homo.	Gritty	Lumpy	Homo.	Homo.
Bright	Bright	Bright	Bright	Bright	Bright	Bright	Bright	Bright	Bright	Bright	Bright
Conch.	Conch.	Conch.	Conch.	Conch.	Conch.	Conch.	Conch.	Conch.
Bright	Bright	Bright	Bright	Bright	Bright	Bright	Bright	Bright
Black	Black	Black	Bn.	Bn. Bk	Black	Black	Black	Black	Black	Black	Black
1.015	1.024	1.036	1.031	1.043	1.065	1.095	1.113	1.127	1.158	1.095	1.120
3.1	4.5	6.5	2.7	3.4	6.8	13.9	28.8	38.0	45.1	8.8	27.2
17.2	21.5	22.9	7.0	18.2	21.5	29.0	63.0	89.2	98.0	24.0	70.2
60.4	38.0	73.0	45.8	55.4	64.6	78.3	> 100	> 100	> 100	58.7	> 100
47.3	47.8	43.5	48.0	47.2	46.6	44.0	> 42	> 40	> 45	43.3	> 45
45	42.5	43.5	31	40	57	12.5	8.0	0	0	70	3.5
8	3.5	3	75	98.5	9	1	0	0	0	22	0
0	0	0	0	0	0	0	0	0	0	0	0
0.4	0.8	0.75	0.15	0.25	0.60	1.65	3.95	3.40	4.25	0.4	4.85
2.8	4.0	5.0	0.55	1.1	3.5	6.2	5.0	4.0	4.2	2.8	5.5
8.5	11.0	10.5	7.5	8.5	10.0	12.0	8.0	5.2	3.7	8.7	10.2
121	133	143	90	108	124	146	168.5	209	218	115	187
141.5	154	162	105	129	142	163	188	220	229.5	132	210
0.76	0.50	0.47	5.20	3.40	3.08	2.44	3.90	3.72	2.12	3.08	2.75
520	555	547	450	492	500	525	535	545	563	528	561
28.9	30.6	32.3	12.0	20.1	24.8	30.2	34.0	37.0	39.7	29.1	38.4
97.50	98.22	97.95	99.80	99.25	98.93	98.67	98.64	98.12	86.20	99.35	98.39
2.15	1.33	1.80	0.05	0.50	1.07	0.90	1.10	1.60	13.48	0.48	1.28
0.35	0.45	0.25	0.15	0.25	0.30	0.43	0.26	0.28	0.32	0.17	0.33
0.6	1.82	2.2	0.5	1.0	1.5	2.5	4.2	5.6	28.2	0.3	0.8
76.8	68.9	62.0	82.5	77.0	71.2	64.1	52.3	45.2	35.7	78.0	66.6
6.4	4.2	5.8	0.9	1.2	1.4	0.8	2.8	2.2
2.6	1.7	1.4	0.2	0.1	Tr.	Tr.	0.0	0.0	0.0	0.0	0.0
38.5	42.9	30.3	22.2	30.6	35.8	37.0	24.0	28.3
97.5	92.5	98.0	96.4

petroleum contain paraffine, between 4 and 8 per cent of sulphur and between 30 and 50 per cent of saturated hydrocarbons. In distilling Mexican petroleum, it is necessary to use a large supply of steam to drive off as much sulphur as possible, and increase the ductility of the residual asphalt, as the sulphur adheres unusually tenaciously to the hydrocarbons, including even the distillates. Residual asphalts obtained from

Trinidad asphaltic petroleum is practically free from paraffine, contains more than $1\frac{1}{2}$ per cent of sulphur, and 25 to 35 per cent of saturated hydrocarbons.

The weather-resisting property of residual asphalts varies, depending upon the following circumstances:

(1) The crude petroleum from which they were derived. Other things being equal, asphaltic petroleum produces the most weather-resisting residues, mixed-base petroleum comes next, and non-asphaltic petroleum produces residuals having the least weather resistance.

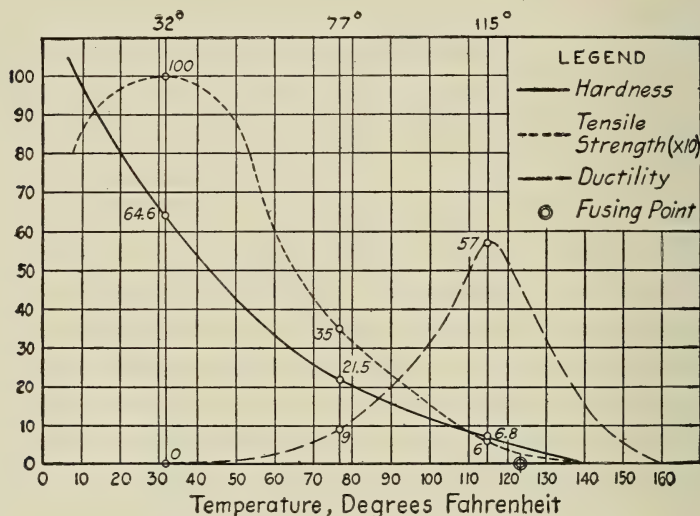

FIG. 113.—Chart of Physical Characteristics of D-Grade California Asphalt.

(2) The care with which the distillation has been performed. If the residue is badly decomposed or “cracked” as evidenced by the presence of free carbon or carbenes, its weather-resisting properties will suffer in proportion.

(3) The extent to which the distillation has been carried. Soft grades of residual asphalt carrying a large percentage of oily constituents (Test 38e), will stand the weather better than those from which the oily constituents have been removed by driving the distillation to a point where a hard and brittle residual asphalt remains.

In general, residual asphalts of the highest quality are inferior in weather-resisting properties to native asphalts, blown asphalts, wurtzilite asphalts and fatty-acid pitches, upon comparing respective products of the same fusing-point and volatility. They are superior, however, to

corresponding sludge asphalts and pitches derived from rosin, wood, peat, lignite, coal and bones.

SLUDGE ASPHALTS

Sludge asphalts are produced in much smaller quantities than residual or blown asphalts. They are derived from the purification of various petroleum distillates by means of sulphuric acid (p. 278). The crude naphtha, kerosene and lubricating oils are treated in this manner in the form of apparatus known as an "agitator," illustrated diagrammatically in Fig. 114, consisting of a cylindrical vessel *A* with a conical bottom and dome-shaped top *B*, holding up to 2400 barrels of the distillate to be treated. The agitator is lined with lead containing about 6 per cent of antimony. The distillate is introduced through the pipe *D*, the acid or caustic soda through the pipe *H*, and the air for agitating the mixture through the line *E*. Pipe *C* is attached to a swivel so that it may be raised or lowered by a chain *J*, and serves to draw off the purified oil. The sludge is removed through the valve *F*, and *G* represents the acid tank.

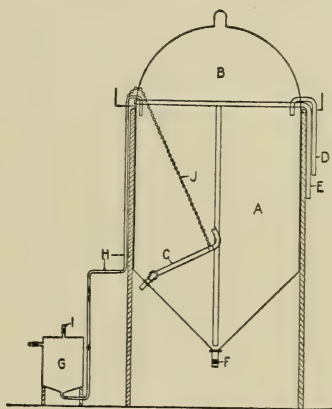

FIG. 114.—Apparatus for the Acid-Purification of Petroleum Distillates.

Naphtha is purified with 2 to 4 lb. of commercial sulphuric acid (66° Baumé) per barrel of 50 gal. (about 0.5 per cent by volume), and agitated for half an hour. The acid after being allowed to settle is drawn off and constitutes the "sludge." The distillate is next washed with water, introduced through the pipe *F*, then made alkaline with caustic soda solution (4 to 10° Baumé) and finally washed with water until it is neutral.

Crude kerosene is treated in a similar manner. It is first agitated with 5 to 10 lb. of sulphuric acid (66° Baumé) per barrel of 50 gal. (equivalent to about 1.5 per cent by volume) for one-half hour. The acid settles in three to five hours, when the "sludge" is drawn off. The kerosene is next washed with water, then with a 4 to 10° Baumé solution of caustic soda and finally with water until it is neutral.

Crude lubricating oil is similarly agitated with 20 to 50 lb. of sulphuric acid (66° Baumé) per barrel of 50 gal. (equivalent to about 3 per cent by volume) for one to two hours, and allowed to settle from four to six

hours. The greater the percentage of acid used, the lighter will be the color of the refined lubricating oil. The stock is then washed with water, transferred to a "lye agitator," treated with caustic soda (1 to 6° Baumé) until it becomes alkaline, and finally washed with hot water until neutral.

The so-called "sludge asphalt" is present in the sulphuric acid sludge, which on cooling forms a black viscous mass. No asphalts are obtained from the caustic soda washings in the case of petroleum refining. The alkali is merely used to neutralize the sulphuric acid retained mechanically by the oil, thus differing from its action in the refining of peat and lignite tars. (See p. 214.)

The acid sludges obtained from the purification of naphtha, kerosene and lubricating oil are combined and treated according to the process of John L. Gray.¹ The sludge is digested with water, air and steam in a lead-lined receptacle, whereupon the lighter oily constituents rise to the surface, a heavy residuum settles to the bottom, and the acid passes into the aqueous layer. The lighter oils are withdrawn and the boiling continued until all the acid separates. The residuum is then washed with water, and heated by a spray of superheated steam until it is converted into sludge asphalt. The further the distillation is continued, the greater the fusing-point and hardness of the sludge asphalt. The recovered oil is known as the "acid oil distillate." The dilute sulphuric acid (specific gravity of 30 to 50° Baumé) is concentrated, first in leaden pans, and finally in an iron still until it attains a gravity of 66° Baumé, when it is used over again.

Sludge asphalt tests as follows:

(Test 1) Color in mass.....	Black
(Test 2a) Homogeneity to the eye at room temperature.....	Uniform
(Test 2b) Homogeneity under microscope.....	Variable
(Test 3) Appearance surface aged indoors one week.....	Bright
(Test 4) Fracture.....	Conchoidal
(Test 5) Lustre.....	Bright
(Test 6) Streak on porcelain.....	Black
(Test 7) Specific gravity at 77° F.....	1.05-1.20
(Test 9b) Penetration at 77° F.....	150- 0
(Test 9c) Consistency at 77° F.....	5-100
(Test 9d) Susceptibility factor.....	40- 60
(Test 10) Ductility at 77° F.....	0
(Test 13) Odor on heating.....	Oily; similar to residual asphalt
(Test 14a) Behavior on melting.....	Passes rapidly from the solid to the liquid state
(Test 15a) Fusing-point (K. & S. method).....	80-225° F.
(Test 15b) Fusing-point (B. & R. method).....	100-250° F.
(Test 16a) Volatile matter 500° F. in 4 hours.....	2- 20%

¹ U. S. Pats. 923,427, 923,428, and 923,429, dated Jun. 1, 1909 to J. L. Gray; also 564,975 of Aug. 4, 1869, to Richard Dean.

(Test 17a)	Flash-point.....	300-500° F.
(Test 19)	Fixed carbon.....	5- 30%
(Test 21a)	Solubility in carbon disulphide.....	95-100%
(Test 21b)	Non-mineral matter insoluble.....	0- 5%
(Test 21c)	Mineral matter ¹	0- 1%
(Test 22)	Carbenes.....	0 -15%
(Test 23)	Solubility in 88° naphtha.....	60- 95%
(Test 28)	Sulphur.....	5- 10%
(Test 30)	Oxygen.....	3- 7%
(Test 33)	Paraffine.....	0- ½%
(Test 34)	Saturated hydrocarbons.....	Less than 10%
(Test 35)	Sulphonation residue.....	80- 95%
(Test 37)	Saponifiable constituents.....	0- 2%
(Test 38a)	Free asphaltous acids.....	Less than 2%
(Test 38b)	Asphaltous-acid anhydrides.....	Less than 2½%
(Test 41)	Diazo reaction.....	No
(Test 42)	Anthraquinone reaction.....	No

Sludge asphalts are characterized by the following features:

- (1) Their intense black streak.
- (2) Their high susceptibility factor which distinguishes them from blown asphalts.
- (3) The high percentage of sulphur.
- (4) The high percentage of oxygen, which distinguishes them from all other forms of asphalt and constitutes one of the most dependable tests for identifying sludge asphalts.
- (5) The very small percentage of paraffine which distinguishes them from residual asphalts obtained from mixed-base petroleum.
- (6) The extremely small percentage of saturated hydrocarbons which serves to differentiate sludge asphalts from all other asphaltic products.
- (7) The comparatively large percentage of sulphonation residue which distinguishes them from pitches.
- (8) The negative diazo and anthraquinone reactions which distinguish them from pitches derived from wood, peat, lignite, coal, shales and bones.
- (9) The large solubility of the harder grades in 88° naphtha, which distinguishes them from residual asphalts of the same hardness and fusing-point.

Attempts have been made to blow sludge asphalts, but without success, as the blowing process merely serves to harden them, without appreciably lowering their susceptibility factor.

Typical samples of sludge asphalt examined by the author gave the results included in Table XXVII, p. 306.

Sludge asphalts do not withstand the action of the weather as well as native asphalts, blown asphalts, residual asphalts, wurtzilite asphalt or

¹ Sludge asphalts all carry traces of lead, derived from the leaden vessels in which they are produced, which is carried into solution by the sulphuric acid. The presence of lead will serve to identify sludge asphalts, and differentiate them from all other asphaltic substances. The author's investigations revealed lead varying in amounts from 0.05 to 0.25 per cent.

fatty-acid pitch, comparing respective products of the same fusing-point and volatility, or of the same hardness and volatility. They are substantially equal in weather-resistance to the corresponding grades of pitch derived from coal and bones, and are superior to those derived from rosin, wood, peat and lignite. In practice, they are usually fluxed with other forms of petroleum asphalt, rather than marketed in their pure state.

TABLE XXVII.—CHARACTERISTICS OF TYPICAL SLUDGE ASPHALTS

No.	Test.	From Various Sources, Mostly Mixtures.					
<i>Physical Characteristics</i>							
2a	Homogeneity to eye at 77° F.	Homo.	Homo.	Homo.	Homo.	Homo.	Homo.
2b	Homogeneity under microscope.	Homo.	Homo.	Homo.	Homo.	Homo.	Homo.
3	Appearance surface aged 7 days.	Bright	Bright	Bright	Bright	Bright	Bright
4	Fracture.	Conch.	Conch.	Conch.	Conch.
5	Lustre.	Bright	Bright	Bright	Bright
6	Streak.	Black	Black	Black	Black	Black	Black
7	Specific gravity at 77° F.	1.057	1.052	1.068	1.090	1.076	1.155
9c	Consistency at 115° F.	0.0	0.0	0.0	0.0	43.1	50.7
	Consistency at 77° F.	3.4	7.1	17.5	19.9	87.9	95.2
	Consistency at 32° F.	42.2	58.8	71.8	85.4	> 100	> 100
9d	Susceptibility factor.	49.7	59.5	61.8	53.4	> 50	> 50
10b	Ductility in cms. at 115° F.	7	15	45	3.5	0	0
	Ductility in cms. at 77° F.	38	82	18	0.75	0	0
	Ductility in cms. at 32° F.	1.5	0	0	0	0	0
11	Tensile strength in kg. at 115° F.	0.0	0.1	0.35	1.3	3.0	3.5
	Tensile strength in kg. at 77° F.	0.4	1.4	3.85	5.4	7.5	8.2
	Tensile strength in kg. at 32° F.	10.5	4.5	3.0	8.0	6.0	5.5
<i>Heat Tests</i>							
15a	Fusing-point, deg. F. by K. & S. method.	85	99	116	160	203	210
15b	Fusing-point, deg. F. by B. & R. method.	101	113	134	178	225	230
16	Volatile, 500° F. in 4 hrs., per cent.	3.0	2.2	7.9	2.5	4.8	5.0
17a	Flash-point, deg. F.	475	500	430	480	482	486
19	Fixed carbon, per cent.	8.8	12.3	16.1	22.0	30.2	25.4
<i>Solubility Tests</i>							
21a	Soluble in carbon disulphide.	98.98	99.72	99.51	99.23	99.50	97.50
21b	Non-mineral matter insoluble.	0.90	0.20	0.38	0.72	0.40	2.43
21c	Mineral matter.	0.12	0.08	0.11	0.05	0.10	0.07
22	Carbenes.	0.0	0.2	2.3	1.0	1.2	13.2
23	Soluble in 88° naphtha.	93.2	94.0	78.7	74.6	66.8	62.2
<i>Chemical Tests</i>							
28	Sulphur.	8.7	7.8	5.4	7.5	6.2	8.3
33	Paraffine.	0.5	0.4	0.2	0.25	0.1	0.1
34	Saturated hydrocarbons.	9.0	8.9	7.2	5.5	4.8	3.9
35	Sulphonation residue.	82.1	88.0	93.2

CHAPTER XX

PARAFFINE WAX AND WAX TAILINGS

PARAFFINE WAX

THE commercial sources of pyrogenous paraffine wax are:

- (1) Peat tar;
- (2) Lignite tar;
- (3) Shale tar;
- (4) Paraffine-bearing petroleums.

The peat distilling industry is comparatively unimportant and does not form a factor in the production of paraffine. The lignite industry has only attained commercial importance in Germany, and the shale industry in Scotland. The treatment of paraffine-bearing petroleums for the recovery of paraffine is important the world around. The methods for recovering paraffine wax from lignite tar, shale tar and petroleum are substantially the same. In the case of lignite tar, the paraffine wax is obtained from the distillate fractioned after the crude oil, known as the "paraffineous mass" (p. 211). With shale tar the paraffine wax is obtained from the distillate known as "heavy oil," distilling after the "intermediate or gas-oil" (p. 223). With paraffine-bearing petroleums, the paraffine wax is obtained from the fraction known as the "paraffine distillate."

In all three cases the following steps are generally pursued:

The distillate containing the paraffine is first chilled to 20 to 25° F. by forcing it through a series of jacketed 6 in. pipes. Brine cooled to 15 to 20° F. is circulated through the jacket, and the distillate containing the paraffine is forced through the inner pipe by a slowly revolving spiral conveyor, which continually keeps the distillate moving as it solidifies, thus tending to granulate it and thus make it easier to filter.

The cooled and solidified distillate having the consistency of heavy mush is transferred to high-pressure filter presses provided with canvas-covered plates, and while still cool filtered at a pressure of 300 to 350 lb., causing the pressed oil to separate from the "slack wax."

The slack wax still contains between 30 and 50 per cent of oily matters which are separated by a process known as "sweating." A "sweater"

(Fig. 115) carries 8 to 10 superimposed shallow pans (18 by 20 by 1 ft.), each provided with a wire gauze diaphragm *A* stretched across longitudinally 6 in. below the top, also:

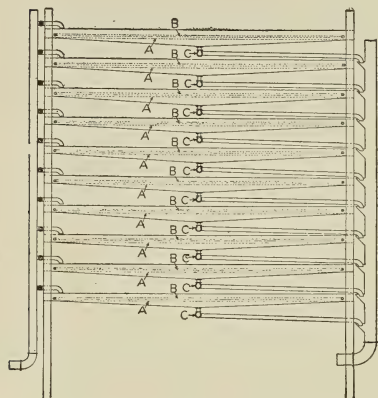

FIG. 115.—Paraffine Wax Sweater.

(1) An inlet for introducing the melted slack wax.

(2) An inlet pipe for water.

(3) An outlet pipe *C* connected with the bottom of each pan at its centre.

(4) A water-circulating coil *B* directly above the diaphragm through which cold water is first circulated to chill the wax, followed by warm water to induce the "sweating."

(5) A steam coil directly below the diaphragm to melt down the wax after the sweating process is completed.

The operations are performed in the following rotation:

(1) The pans are first filled with cold water to $\frac{1}{8}$ in. above the level of the screens.

(2) The melted "slack wax" is pumped into the pans to a depth of 4 in. and allowed to float on the water.

(3) Cold water is then caused to flow through the water-circulating system, which causes the slack wax to set into a solid mass.

(4) The water is then drawn off, whereupon the cake of solid wax settles upon the wire diaphragm.

(5) Warm water is then caused to flow through the water-circulating coils at a temperature just below the melting-point of the wax, which causes the oily matters to liquefy and "sweat out" from the crystals of paraffine, with the result that the purified paraffine now known as "crude wax" remains on the wire gauze. The oily matter carrying a small proportion of wax in solution, known as "foots oil" is drawn from the pans. The purified paraffine wax is melted by turning steam into the melting-down coils and drawn from the pans into a separate container. It takes about twenty-four hours to properly sweat a batch of slack wax.

The foots oil is put through the chilling process a second time to recover any dissolved wax, which when separated is known as "crude scale wax" (see chart page 278).

The crude wax and the crude scale wax are decolorized by filtering through fuller's earth in vertical cylindrical tanks heated to 180° F. The melted wax is allowed to run through the filters by gravity from an over-

head storage tank where it is maintained in a melted condition. The filters are from 15 to 20 tons' capacity, the fuller's earth being supported on a finely perforated false bottom. One ton of the earth will decolorize 5 to 6 tons of the wax.

When the fuller's earth loses its efficiency, which is evidenced by the filtrate no longer remaining clear in color, the flow of wax is shut off, the filter bed thoroughly drained and washed with naphtha to remove any wax retained mechanically. Any naphtha remaining in the filtering medium is recovered by introducing steam and passing the vapors through a condenser. The wax removed by the naphtha is recovered by distillation, and added to the unfiltered material.

The fuller's earth may be rejuvenated by heating in a suitable kiln, after which it can be used over again without loss in efficiency.

The filtered products obtained from the crude wax and crude scale wax are known as "refined paraffine wax" and "refined scale wax" respectively. These are pumped into moulds and allowed to solidify. The wax must be chilled very quickly to form the opaque white mass demanded by the trade, otherwise it will appear translucent, which is undesirable.¹

Paraffine wax, including both the "refined paraffine wax" and the "refined scale wax" tests as follows:

(Test 1) Color in mass.....	Pure white to yellowish
(Test 2a) Homogeneity to the eye at room temperature...	Uniform to slightly crystalline
(Test 2c) Homogeneity when melted.....	Uniform and transparent
(Test 4) Fracture.....	Conchoidal to hackly
(Test 5) Lustre.....	Dull and "waxy"
(Test 6) Streak.....	White
(Test 7) Specific gravity at 77° F.....	0.85- 0.95
(Test 9c) Consistency at 77° F.....	15 -80
(Test 9d) Susceptibility factor	>100
(Test 10) Ductility at 77° F.....	0
(Test 14a) Behavior on melting.....	Passes almost instantaneously from the solid to the liquid state
(Test 15a) Fusing-point ² (K. & S. method).....	100-150° F.
(Test 15b) Fusing-point (B. & R. method).....	105-160° F.
(Test 16) Volatile matter.....	Comparatively great

¹ "Mineral Waxes," Rudolf Gregorious, London, 1908; "Shale Oils and Tars," by Dr. W. Scheithauer, London, 1913; "Industrial Chemistry," by Allan Rogers, 2d edition, p. 512, New York, 1915; "The American Petroleum Industry," by Bacon and Hamor, Vol. 2, pp. 459 and 753, New York, 1916.

² The fusing-point of paraffine wax is generally determined by the so-called "English method," which consists in cooling the melted wax, with a thermometer immersed in the mass. The drop in temperature and time intervals are carefully noted. When the temperature remains constant for an appreciable interval, the wax is said to have reached its fusing or "melting-point." According to the "American method," the melting-point is reached when crystals of paraffine first appear on the surface of the cooling wax, but is often arbitrarily calculated by adding 3° F. to the melting-point ascertained by the English method.

(Test 17a)	Flash-point.....	Comparatively low
(Test 18)	Burning-point.....	Comparatively low
(Test 19)	Fixed carbon.....	0- 2%
(Test 21a)	Solubility in carbon disulphide.....	99-100%
(Test 21b)	Non-mineral matter insoluble.....	Trace
(Test 21c)	Mineral matter.....	Trace
(Test 22)	Carbenes.....	0%
(Test 23)	Solubility in 88° naphtha.....	99-100%
(Test 24)	Solubility in other solvents (weight solvent required to dissolve 1 gram of paraffine at room temperature):	
	Carbon disulphide.....	7.6
	Petroleum ether.....	8.5
	Turpentine.....	16.1
	Chloroform.....	41.3
	Benzol.....	50.3
	Ether.....	50.8
	Acetone.....	378.7
	Absolute ethyl alcohol.....	453.6
	Amyl alcohol.....	495.3
	Methyl alcohol.....	1447.5
	Glacial acetic acid.....	1668.6
(Test 26)	Carbon.....	84- 86%
(Test 27)	Hydrogen.....	13- 15%
(Test 28)	Sulphur.....	Trace
(Test 29)	Nitrogen.....	Absent
(Test 30)	Oxygen.....	Trace
(Test 33)	Paraffine.....	95-100%
(Test 34)	Saturated hydrocarbons.....	90- 99%
(Test 35)	Sulphonation residue.....	95-100%
(Test 37)	Saponifiable constituents.....	0%
(Test 41)	Diazo reaction.....	No
(Test 42)	Anthraquinone reaction.....	No

Paraffine wax is remarkably resistant to the action of chemicals, but on exposure to the weather the oily constituents soon evaporate, leaving a pulverulent and but slightly coherent mass behind. This is not due to oxidation, but merely to volatilization of the oils present in the wax.

Paraffine wax withstands the continuous action of water very well and finds a ready market for preparing waterproof papers, for manufacturing candles, for household purposes, etc.

WAX TAILINGS

This product is obtained during the dry distillation of non-asphaltic or mixed-base petroleum. The residuum left in the retort at the end of the first distillation is subjected to a second process of dry distillation, whereupon the wax tailings distil over just prior to the formation of coke. (See p. 282.) Wax tailings is sometimes termed "still wax," although both these names are misnomers, since it contains only small quantities of paraffine wax. It consists largely of decomposition products, including chrysene, picene and anthracene, and has a decided

yellow color, by which it is recognized during the process of distillation. Upon cooling it forms a very viscous semi-liquid to sticky semi-solid of a characteristic light yellow to yellowish brown color. It complies with the following tests:

(Test 1)	Color in mass.....	Yellow to yellowish brown
(Test 2a)	Homogeneity to the eye at room temperature...	Uniform to very slightly granular
(Test 2b)	Homogeneity under microscope.....	Uniform to gritty (due to the crystalline constituents present)
(Test 3)	Appearance surface aged indoors.....	Variable
(Test 5)	Lustre.....	Waxy
(Test 6)	Streak on porcelain.....	Pale yellow
(Test 7)	Specific gravity at 77° F.....	1.00- 1.10
(Test 9c)	Consistency at 77° F.....	5 -20
(Test 9d)	Susceptibility factor.....	20-40
(Test 10)	Ductility at 77° F.....	Usually quite high
(Test 13)	Odor on heating.....	Oily
(Test 14a)	Behavior on melting.....	Passes very rapidly from the solid to the liquid state
(Test 15a)	Fusing-point (K. & S. method).....	60-100° F.
(Test 16a)	Volatile matter at 500° F., 4 hrs.....	5-10 %
(Test 17a)	Flash-point.....	300-450° F.
(Test 19)	Fixed carbon.....	2- 8%
(Test 21a)	Solubility in carbon disulphide.....	98-100%
(Test 21b)	Non-mineral matter insoluble.....	0- 2%
(Test 21c)	Mineral matter.....	0-Trace
(Test 22)	Carbenes.....	0-Trace
(Test 23)	Solubility in 88° naphtha.....	95-100%
(Test 28)	Sulphur.....	0-Trace
(Test 30)	Oxygen.....	0- 2%
(Test 32)	Naphthalene.....	Absent
(Test 33)	Paraffine.....	Tr.- 5%
(Test 34)	Saturated hydrocarbons.....	40- 70%
(Test 35)	Sulphonation residue.....	90-100%
(Test 37)	Saponifiable constituents.....	Trace
(Test 41)	Diazo reaction.....	No
(Test 42)	Anthraquinone reaction.....	Yes

Wax tailings is an exceedingly good flux, and will thoroughly amalgamate with the harder asphalts and asphaltites, including even grahamite. It forms a better flux than the residual oils derived from asphaltic petroleum. A very small percentage will often serve to thoroughly flux materials which are otherwise incompatible, and at the same time increase the ductility of the mixture. Certain asphalts, although they may flux together at high temperatures, will separate partially on cooling, forming a very finely granular condition, which is particularly noticeable when the surface of the mixture is freshly disturbed, or upon drawing a small pellicle into a thread. The presence of a small percentage of wax tailings will often prevent this, and it therefore enjoys a unique position among the fluxes. Large quantities, however, should be avoided as wax tailings is extremely susceptible to changes in temperature and lacks weather-proof properties. The presence of wax tailings will increase the solubility of asphaltic substances in petroleum distillates, and accordingly becomes useful for manufacturing certain types of bitu-

minous paint. A representative sample of wax tailings tested by the author gave the following results:

(Test 9c)	Consistency at 115° F.....	0.0
	Consistency at 77° F.....	5.9
	Consistency at 32° F.....	22.9
(Test 9d)	Susceptibility factor.....	25.0
(Test 10b)	Ductility at 115° F.....	1.1
	Ductility at 77° F.....	3.9
	Ductility at 32° F.....	13.5
(Test 11)	Tensile strength at 115° F.....	0.0
	Tensile strength at 77° F.....	0.5
	Tensile strength at 32° F.....	9.5
(Test 15a)	Fusing-point (K. & S. method).....	90° F
(Test 15b)	Fusing-point (B. & R. method).....	98° F.
(Test 17a)	Flash-point.....	382° F.

The production of wax tailings is not large, and it is not, therefore, of great importance to the asphalt industry.

CHAPTER XXI

WURTZILITE ASPHALT

WURTZILITE asphalt or wurtzilite pitch, marketed under the name of "kapak," is produced by cracking or depolymerizing wurtzilite (p. 150). It is similar to the latter in its physical characteristics with the exception of:

- (1) The hardness, which is very much reduced.
- (2) Its fusibility. Treated wurtzilite is fusible whereas crude wurtzilite is not.
- (3) Its solubility. Treated wurtzilite is readily soluble in carbon disulphide, and moderately so in 88° naphtha, whereas the crude product is practically insoluble in both.

The process consists in heating the wurtzilite in a closed vessel or still to a temperature of 500 to 580° F., under more or less pressure. Vapors are evolved during the process which are condensed and returned to the still, and in turn attack the wurtzilite, first reducing it to a plastic mass, which after heating is converted into a fusible substance. If the vapor pressure becomes too great, some is allowed to escape. The process which takes place is virtually a "depolymerization" (see p. 58).¹

In practice, the wurtzilite is first run through a crusher to break up any coarse lumps, and then fed into a horizontal cylindrical still through two charging hoppers, one at either end, provided with tightly fitting covers which are fastened into place before the fires are started. The bottom of the still is protected by a fire-brick arch, and the products of combustion after passing underneath the arch, are returned in three fire-flues running through the still (one 10 in. in diameter and two 6 in.), and thence back again in the space surrounding the still, above the arch. The vapors generated from the wurtzilite pass upward through two pipes joined to the top of the still, near the ends, and connected with a single water-cooled coil, which condenses the vapors and returns most of the condensate to the still. Not all the condensate is returned, however, for

¹ U. S. Pats. 616,047 of Dec. 13, 1898, 617,706 of Jan. 17, 1899, and 620,082 of Feb. 21, 1899, all to C. E. Anthony; 655,130 and 655,131 of July 31, 1900 also 716,787 of Dec. 23, 1902, all to R. M. Thompson; 734,482 and 734,483 of July 21, 1903 to S. R. Whitall; 768,101 of Aug. 23, 1904 to F. M. Whitall; 864,836 of Sept. 3, 1907 to W. F. Doerflinger and L. H. Buck; 984,240 of Feb. 14, 1911 to J. C. Ross.

practice has demonstrated that the optimum results are obtained if 2 to 5 per cent of the distillate (based on the weight of wurtzilite charged into the still) is drawn off. This may be used as fuel under the still.

The longer the wurtzilite is heated in its process of manufacture the greater the quantity of oils produced, which act in the same manner as a flux, and hence lower will be the fusing-point and hardness of the resultant product.

It takes six to eight hours to raise the temperature of the charge to 400° F., then four to six hours to reach the maximum temperature (580° F.), which is maintained from twenty-four to thirty-six hours. The contents are then allowed to cool to 450° F., and finally drawn off through a valve at the bottom.

According to the author's investigations, Nova Scotia albertite is also amenable to this process, although up to the present time it has not been treated thus commercially.

The wurtzilite products are marketed under various arbitrary numbers ranging from "0" to "16," each of which is recommended for a specific purpose, including the manufacture of paints and varnish, insulators, for manufacturing insulated wire, for weather-proofing conduits and cables, as a filler for mechanical and hard rubber compounds cured by the press or open steam method, for coating prepared roofings, for manufacturing carriage drills and similar compositions applied by the calendar process and cured by the dry heat method, etc. Certain of these compounds represent mixtures of wurtzilite asphalt and gilsonite, with or without the addition of asphaltic fluxes (e.g. residual oil), and vegetable oils (e.g., linseed oil, palm oil, etc.).

Wurtzilite asphalt complies in general with the following characteristics:

(Test 11)	Color in mass.....	Black
(Test 2a)	Homogeneity to the eye at room temperature.....	Uniform
(Test 2b)	Homogeneity under microscope.....	Uniform
(Test 3)	Appearance surface aged indoors one week.....	Very bright
(Test 4)	Fracture.....	Conchoidal
(Test 5)	Lustre.....	Bright
(Test 6)	Streak on porcelain.....	Brown to black
(Test 7)	Specific gravity at 77° F.....	1.04- 1.07
(Test 9c)	Consistency at 115° F.....	10 - 25
	Consistency at 77° F.....	20 - 50
	Consistency at 32° F.....	50 -120
(Test 9d)	Susceptibility factor.....	30 - 40
(Test 10b)	Ductility at 115° F.....	1 - 5
	Ductility at 77° F.....	0 - 1
	Ductility at 32° F.....	0
(Test 11)	Tensile strength at 115° F.....	1 - 4
	Tensile strength at 77° F.....	5 - 10
	Tensile strength at 32° F.....	8 - 15
(Test 15a)	Fusing-point (K. & S. method).....	150 -300° F.

(Test 15b) Fusing-point (B. and R. method).....	170	-325° F.
(Test 16a) Volatile matter, 500° F., 4 hours.....	Less than 5%	
(Test 17a) Flash-point.....	450	-600° F.
(Test 19) Fixed carbon.....	5	- 25%
(Test 21a) Solubility in carbon disulphide.....	98	-100%
(Test 21b) Non-mineral matter insoluble.....	0	- ½%
(Test 21c) Mineral matter.....	Tr.	- 2%
(Test 22) Carbenes.....	0	- 2%
(Test 23) Solubility in 88° naphtha.....	50	- 80%
(Test 28) Sulphur.....	4	- 6%
(Test 30) Oxygen.....	0	- 2%
(Test 33) Paraffine.....	0	-Trace
(Test 34) Saturated hydrocarbons.....	5	- 12%
(Test 35) Sulphonation residue.....	90	- 95%
(Test 37) Saponifiable constituents.....	Trace	
(Test 41) Diazo reaction.....	No	
(Test 42) Anthraquinone reaction.....	No	

Specimens of the unfluxed wurtzilite asphalt examined by the author tested as follows:

	No. 0.	No. 1.	No. 6.	No. 16.
(Test 9c) Consistency at 115° F.....	22.9	18.5	15.0	11.7
Consistency at 77° F.....	45.6	41.8	38.5	32.4
Consistency at 32° F.....	110.0	92.2	80.6	71.1
(Test 9d) Susceptibility factor.....	32.4	33.4	32.8	31.2
(Test 15a) Fusing-point (K. and S. method).....	269	220	200	190
(Test 10b) Ductility at 115° F.....	2	3	3	4
Ductility at 77° F.....	0	0	0	½
Ductility at 32° F.....	0	0	0	0

These figures indicate that the extent of softening and lowering of the fusing-point is dependent upon the extent to which the process of depolymerization has progressed. It is interesting to observe in this connection that the susceptibility factor remains practically unchanged.

Wurtzilite asphalt is characterized by its low specific gravity, high-fusing-point, low susceptibility factor, extreme toughness and rubber-like properties (i.e., resiliency), high-tensile strength, small percentages of oxygen and non-mineral matter, large percentage of sulphonation residue, and absence of saponifiable constituents.

It is quite similar in many respects to blown asphalts (particularly in regard to its susceptibility factor), but may be differentiated from these by:

- (1) A greater hardness or consistency at 77° F. for any given fusing-point.
- (2) A greater tensile strength for any given fusing-point.
- (3) Smaller percentages of oxygen.
- (4) Smaller percentages of saturated hydrocarbons.

Wurtzilite asphalt is also similar in many respects to the fatty-acid pitches, especially in its toughness (resilience) and its low susceptibility factor. It is distinguished from these, however, by the following:

(1) Its solubility in 88° naphtha, which is smaller than in the case of fatty-acid pitches.

(2) The presence of sulphur, which is absent in the fatty-acid pitches.

(3) The smaller percentage of oxygen.

(4) The larger percentage of sulphonation residue.

(5) The absence of saponifiable constituents.

In other respects they are apt to test pretty much alike.

Wurtzilite asphalt shows remarkable weather-resistance and finds its greatest use in manufacturing asphalt paints and for coating prepared roofings. Its use is limited by the small quantity produced, and the comparatively high price at which it is marketed.

CHAPTER XXII

FATTY-ACID PITCH, BONE TAR AND BONE-TAR PITCH

THESE are classified together because all are derived from substances containing animal or vegetable fats or oils, although in manufacturing bone tar and bone-tar pitch the crude materials carry but a small proportion.

FATTY-ACID PITCH

Various generic terms have been used to designate this product, including candle tar, "Kerzenterr" (German), "goudron" (French), candle pitch, fat pitch and "Fettpech" (German). Specific names have also been applied, descriptive of the raw materials used in producing the pitch, such as stearin pitch, palm-oil pitch, bone-fat pitch, cotton-seed-oil pitch, cotton pitch, cotton-stearin pitch, cotton-seed-foots pitch, corn-oil pitch, corn-oil-foots pitch, packing-house pitch, garbage pitch, sewage pitch, fuller's-grease pitch, wool pitch, wool-grease pitch, wool-fat pitch, cholesterol pitch, and stearin-wool pitch.

The fatty-acid pitches are obtained as by-products in the following manufacturing processes:

- (1) Production of candle and soap stocks.
- (2) Refining vegetable oils by means of alkalies.
- (3) Refining refuse greases.
- (4) Treatment of wool grease.

The raw materials used include the vegetable oils and fats, animal oils, fats and waxes (wool grease), also the waste greases derived from the foregoing. Vegetable and animal fats and oils are combinations of the fatty acids with glycerin, known as "triglycerides," and illustrated by the following generic formula, in which "R" represents any fatty acid radicle:

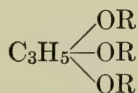

Fats and oils may be purified or refined in two ways:

- (1) By treating vegetable oils with a small amount of caustic soda to remove the coloring matter, free fatty acids and other impurities, with-

out, however, breaking up the triglycerides. This process is used for refining vegetable oils when they are to be used for edible purposes. The residue is treated with mineral acid to break up the soaps, and then distilled with steam to recover the fatty acids, whereupon a residue of fatty-acid pitch is obtained.

(2) By decomposing or "hydrolyzing" the triglycerides into glycerin and free fatty acids, and then distilling the latter with steam, whereby fatty-acid pitch is obtained as a residue. The object of distilling the fatty acids is to *improve their color or odor* and thereby adapt same (a) for the manufacture of candles (which are commonly light colored or white), or (b) for manufacturing soaps (such as toilet soaps, etc.) which must be *odorless* and preferably light-colored.

Production of Candle and Soap Stocks. These are obtained from various animal and vegetable oils and fats, also from waste greases. It is *always* necessary to subject the fatty acids to a process of hydrolysis and steam distillation for producing candles, but not for manufacturing soaps, unless the fatty acids are too dark in color for the character of soap required or possess a disagreeable odor, in which event they are purified by distillation. Various methods of hydrolysis may be used, but they all depend upon the same reaction, in which the triglyceride combines with water and decomposes into glycerin and fatty acids, as illustrated in the following equation:

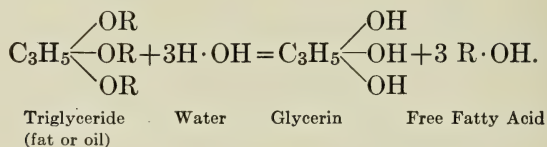

It is *necessary* to hydrolyze the fats or oils before distilling the fatty acids, since the triglycerides themselves are not capable of being distilled without decomposition. The following methods of hydrolysis have been used:

(a) *Hydrolysis by Means of Water.* Formerly, water alone was used for the purpose, the fat or oil being heated in an autoclave with 30 per cent of its weight of water at 220 lb. pressure (corresponding to a temperature of 200° C.) for eight to twelve hours. This decomposes the triglyceride into fatty acids and glycerin, but with water alone it is difficult to break down the fat completely. It has been found that the addition of 3 per cent of lime or magnesium oxide, and preferably the latter, assists the reaction and produces a larger yield of a better product, and at a much lower temperature. Accordingly the fat or oil is heated at 120 lb. pres-

sure in a horizontal or vertical cylindrical vessel provided with a stirring device, with 20 to 25 per cent by weight of water and 3 per cent of lime or magnesium oxide. The breaking down of the fat is practically complete at the end of eight to ten hours, and in addition the color is very much better, as there is less decomposition, due to the lower temperature employed. The fats or oils used for this purpose may consist of animal or vegetable tallow, palm oil, bone fat, lard- or cotton-seed stearin (crystallized at low temperatures from lard or cotton-seed oil respectively), shea butter, etc.

At the end of the process, the free fatty acids rise to the surface and are skimmed off, leaving the aqueous liquor containing the glycerin (together with the hydrated lime or magnesia, when the latter are used). The glycerin is recovered by a special process which, however, does not fall within the scope of this treatise. The fatty acids are subjected to steam distillation to deodorize and whiten them, also to purify them by separating any non-hydrolyzed fat. The fatty acids are run into lead-lined tanks where they are first treated with dilute sulphuric acid to remove any traces of magnesium oxide, etc., then washed with water, heated to expel the moisture, after which they are fed into a retort and distilled with superheated steam with or without the use of vacuum. The fatty acids suitable for distillation should not contain more than 5 per cent of non-hydrolyzed fat (neutral fat) nor more than 0.2 per cent of mineral matter. To obtain a distillate of good quality, care should be taken not to distil the fatty acids at too high a temperature as they are extremely susceptible to overheating and decomposition into dark-colored hydrocarbons (unsaponifiable), which would, of course, depreciate the value of the distillate. The still should be constructed so that the flames will not come into direct contact with the bottom and cause local overheating. The temperature of the material in the still should preferably be maintained between 230 and 250° C., and although in certain instances it is permissible to reach a temperature of 270° C., under no circumstances should this be exceeded.

Two methods are used for conducting the distillation. The first consists in continuously replacing the fatty acids, as they distil with an equivalent quantity of undistilled material, as long as the distillate shows a satisfactory color and is free from unsaponifiable hydrocarbons. The effect of the distillation is to concentrate the impurities and unsaponified (neutral) fats or oils in the still. The distillation conducted in this manner may be continued for five to six days before it becomes necessary to clean out the retort, which is then filled entirely with a soft fatty-acid pitch. The second method consists in replacing the distilled fatty acids for but

sixteen to twenty-four hours, then discontinuing the addition, and distilling the contents of the retort until the distillate ceases to be of suitable quality, as is evidenced by a change in its color. The residue consisting of soft fatty-acid pitch is then drawn off into a separate still known as the "pitch still," the first still recharged, and the process repeated, until after a sufficient number of distillations a sufficient quantity of soft fatty-acid pitch accumulates for further treatment. It is claimed that the second method gives better results and yields a distillate lighter in color and containing a smaller percentage of hydrocarbons.

In either case the soft residue is distilled separately with superheated steam and vacuum. When the neutral fats increase in concentration to 12 to 15 per cent they commence to decompose into hydrocarbons, some of which distil with the fatty acids and some remaining with the residue. This portion of the distillate known as "still returns" is accordingly caught separately and returned to the first still to be worked up with another charge of undistilled fatty acids, whence it derives its name. The final residue constitutes the so-called "fatty-acid pitch."

The following figures will give an idea of the yields from the fatty acids derived from fats and oils hydrolyzed by the treating with 2.6 to 3 per cent of magnesium oxide at a pressure of nine atmospheres for eight to ten hours.¹

	Quantity Distilled, Tons.	Time Dis- tillation, Hours.	Yield Distillate, Per Cent.	Still Returns, Per Cent.	Fatty-acid Pitch, Per Cent.
Lard stearin.....	8	36	95.6	2.1	2.3
Vegetable tallow.....	5	35	92.4	4.0	3.6
Tallow.....	5	36	94.2	2.3	3.5
Bone fat.....	5	38	91.5	5.0	3.5
Palm oil.....	5	37	91.3	4.5	4.2
Shea butter.....	5.3	29	94.1	2.4	3.7

The distilled fatty acids are next separated into two portions representing those of low and high molecular weights respectively, by cooling and crystallization. The mass is first cooled to a low temperature and filter-pressed. The filtrate known as the "saponification olein" is cooled again and repressed to separate any additional quantities of "saponification stearin." The latter is combined with the "saponification stearin" separated from the first pressing which is then treated at a higher temperature in a steam-heated press to remove the last traces of "saponification olein." The following yields are obtained:

¹ Kassler, *Chem. Rev. Fett-Harz-Ind.*, 9, 49, 1902.

	Producing Low Melting-point Stearin, Per Cent.	Producing High Melting-point Stearin, Per Cent.
Saponification stearin.....	49-51	44-46
Saponification olein.....	42-41	47-46
Saponification glycerin (sp. gr. 1.24)...	9-10	9-10
Fatty-acid pitch.....	4-5	4-5

The saponification stearin may be used for manufacturing candles, in which event it is generally mixed with a certain percentage of paraffine wax, or in some instances it may be used for producing hard white soaps. The saponification olein may be used for manufacturing soaps or wool oils (cloth oils), or it may be converted by a hydrogenation process into substances of higher melting-points, suitable for producing candles.

(b) *Hydrolysis by Means of Concentrated Sulphuric Acid.*¹ The fats or oils are first freed from moisture by heating to a temperature of 120° C. It is essential that all the moisture be removed to prevent excessive decomposition. The mass is then *rapidly* mixed with 4 to 6 per cent of concentrated sulphuric acid (66 to 67° Baumé) and heated in a cylindrical vessel provided with a mechanical agitator. The heating is continued just long enough to break up the triglycerides and no longer. The sulphonated mass is then immediately run into boiling water and agitated by a steam jet until the sulphonated acids hydrolyze. The mass is then allowed to stand quietly until the free fatty acids rise to the surface, leaving the glycerol and sulphuric acid in the lower layer.

The fatty acids produced in this manner are dark colored and *must* be distilled. They are first washed with water until neutral, then heated to expel the moisture and finally distilled with superheated steam with or without a vacuum as previously described, whereupon a residue of *soft fatty-acid pitch* is obtained. According to modern practice, this residue is again treated with concentrated sulphuric acid to hydrolyze any neutral fats remaining, and incidentally remove the accumulated mineral matter (including any copper or iron derived from the stills). It is then washed free from the acid and redistilled, leaving a residue of *medium to hard fatty-acid pitch*. The dark colored distillate, known as "still returns," is worked up in small quantities with the crude fatty acids undergoing their first distillation.

The yield of stearin known in this case as "distillation stearin" is greater than that obtained in the aqueous process of hydrolysis, due to the fact that some of the olein (in this case known as "distillation olein")

¹ O. Rosauer, *Chem. Rev. Fett-Harz-Ind.*, 15, 174, 1908.

or "distilled olein") is converted into a solid product (consisting of stearolactone, isomeric oleic acid, etc.). The olein and stearin are separated by cooling exactly as in the foregoing process. A smaller yield of glycerin is obtained due to its partial decomposition by the acid, and that of fatty-acid pitch is also less and of a darker color.

The following yields are obtained:

Distilled stearin or distillation stearin.....	61-63%
Distilled olein or distillation olein.....	30-32%
Distilled glycerin or distillation glycerin.....	8-9%
Fatty-acid pitch.....	2-3%

To avoid losing the glycerin, which constitutes one of the most important and highest priced products, a "mixed process" is now used consisting of a combination of the foregoing.

(c) *Hydrolysis by the "Mixed Process."* This is a combination of the two foregoing processes, and consists in first hydrolyzing the fats or oils in an autoclave with water and an alkaline accelerating agent (such as lime or magnesium oxide), and in this way recovering the full amount of glycerin. The resulting fatty acids are dehydrated and treated with concentrated sulphuric acid in accordance with process (b) to increase the yield of stearin and complete the hydrolysis of any neutral fat which may have escaped the first treatment, and thus minimize the formation of hydrocarbons in the distillate.

The following yields are obtained:

	Quantity Distilled, Tons.	Time Dis- tillation, Hours.	Yield, Distillate, Per Cent.	Still Returns, Per Cent.	Fatty-acid Pitch, Per Cent.
Tallow.....	5-7	33-34	94.6-94.8	2.0-2.6	2.8-3.2
Bone fat.....	5-5.6	34-35	90.3-92.8	4.2-5.4	3.0-4.3
Palm oil.....	5	32-36	91.0-91.6	4.6-5.3	3.7-3.8

The following products are obtained on treating tallow:

Distilled stearin.....	61-63%
Distilled olein.....	32-30%
Distilled glycerin (sp. gr. 1.24).....	10%
Fatty-acid pitch.....	2-3%

(d) *Hydrolysis by Means of Sulpho-compounds.* This process, known as the Twitchell method, is rapidly replacing the others, and is now employed in soap factories for treating the fats or oils before soap-making, as it separates a purer glycerin and at the same time results in a greater yield (88 to 90 per cent of the theoretical quantity contained in the fat or oil vs. 80 to 84 per cent obtained in the direct caustic soda saponificator

method for soaps). Moreover, the liquor separated in the Twitchell process is not contaminated with the sodium chloride used for "salting out" the soap in the ordinary method, and it contains 15 per cent by weight of glycerin against 3 to 4 per cent in the liquor obtained on direct saponification of the fats or oils with sodium hydroxide. The former therefore effects a saving in evaporation.

The fat or oil is first purified by steaming with 1 per cent of 60° Baumé sulphuric acid for about two hours. It is then transferred to a wooden vessel equipped with perforated steam pipes also a well-fitting cover to exclude air which would cause the fatty acids to darken, and mixed with 50 per cent water and 1.5 per cent of the Twitchell reagent. The latter is prepared by allowing an excess of sulphuric acid to act on a solution of naphthalene (or other aromatic hydrocarbon) in oleic acid, which results in the production of a body having the general composition:¹

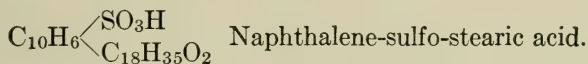

It is advisable to introduce a small percentage of free fatty acids to start the hydrolysis which otherwise takes a little time to begin. The material is steamed for twenty-four hours, whereupon a small quantity (0.1 to 0.2 per cent) of 60° Baumé sulphuric acid is added to break up the emulsion and permit the fatty acids to rise to the surface and the glycerol to pass into the aqueous liquor below. About 0.05 per cent of barium carbonate is finally added to neutralize the mineral acid.

The resulting fatty acids are dark in color and must be distilled. This is usually affected after a preliminary treatment with concentrated sulphuric acid as in method (b) to increase the yield of stearin, which is of special importance when the product is to be used for manufacturing candles. The yield is the same as obtained from the saponification or mixed process respectively, depending upon the exact method of treatment.

A new reagent has recently appeared on the market under the name "kontakt," discovered by the Russian chemist Grigori Petroff,² consisting of aromatic sulpho derivatives prepared from Baku mineral oils (specific gravity 0.879) by means of fuming sulphuric acid. It is supposed to have the general formula $\text{C}_n\text{H}_{2n-9} \cdot \text{SO}_3\text{H}$, and is marketed in the form of the soda or potash salts to secure a more concentrated product. This catalyzer does not darken the fats or oils, as was the case with the earlier reagent, and hence it becomes unnecessary to distil the resulting free fatty acids in making high-grade soaps, unless the raw fats or oils are themselves

¹ U. S. Pat. 601,603 of Mar. 29, 1898, to Ernest Twitchell.

² French Pat. 448,207 of Aug. 31, 1912; U. S. Pat. 1,233,700 of Jul. 17, 1917, to Grigori Petroff.

very dark in color. With high grade stock, $\frac{1}{2}$ to 1 per cent of kontakt is used, and with low grade materials, such as yellow or brown greases, 1 to 2 per cent.¹

This process is adapted particularly for treating raw materials of low quality, including "greases," which do not readily yield to method (a).

(e) *Hydrolysis by Means of Ferments.* This method is also meeting with some favor, as it produces a large yield of glycerin uncontaminated with salt or other solids difficult of separation. Many soap manufacturers accordingly hydrolyze their stock by means of ferments to separate the glycerin, and then saponify the resulting fatty acids with sodium carbonate either direct or after first purifying them by steam distillation.

The ferment is derived from the castor plant by grinding the decorticated castor beans with water and filtering through cloth, whereupon a white creamy filtrate is obtained which is set to one side and allowed to ferment spontaneously. The ferment which rises to the surface, is skimmed off and used while fresh. It is composed of a thick creamy substance containing approximately 38 per cent of fatty acids derived from castor oil, 58 per cent of water and 4 per cent of an albuminoid substance containing the active material.

The fat or oil to be treated is mixed with 40 per cent water, 5 to 8 per cent of the ferment and 0.2 per cent of manganese sulphate in a lead-lined vessel equipped with a steam coil and a perforated compressed-air pipe. Heat is then turned on, and the temperature maintained 2 to 3° C., above the melting-point of the fat or oil. The mass is agitated by air introduced through the perforated pipe and the treatment continued one to three days until the hydrolysis is complete. Sufficient steam is then turned on to bring the mass to a temperature of 80 to 85° C., whereupon 0.30 to 0.45 per cent of 50 per cent of sulphuric acid is stirred in by air. This breaks up the emulsion, the clear fatty acids rising to the top and the aqueous liquor containing the glycerin settling to the bottom.

When the separated fatty acids are pale in color they may be saponified directly for manufacturing soaps. Where dark-colored fats, oils or greases have been employed, which result in the production of dark-colored fatty acids the mass is distilled with steam, whereupon the fatty-acid pitch is obtained as residue. Candle stock may also be produced by subjecting the purified fatty acids to a low temperature and filtering, as described previously.

It is, of course, understood that when the crude oils or fats (triglycerides) or the free fatty acids derived from them (by any of the foregoing

¹"A New Catalytic Reagent for Splitting Glycerin from Fats and Oils," by R. E. Divine, *Am. Perfumer*, **11**, 377, 1917.

processes of hydrolysis) are saponified *directly* with sodium carbonate (soda ash), no fatty-acid pitch is produced.

Refining Vegetable Oils by Means of Alkali. Most vegetable oils intended for edible purposes, whether they are to be used for salad oils, lard substitutes, margarine manufacture, or directly for cooking oils and shortening, are first treated with caustic soda for the purpose of removing free acids, coloring matter, albuminous material, resins, etc. The oils chiefly treated are cotton-seed, corn, soya bean, cocoanut and peanut oils.

(a) *Refining Cotton-seed Oil.* Crude cotton-seed oil when obtained fresh from the seed varies in color from reddish brown to almost black. This is due in part to the coloring matter, which is a dark resinous substance capable of combining with caustic soda forming a water-soluble salt, also albumin and pectin bodies. The method of refining the oil consists in agitating it with varying quantities of caustic soda solution, the strength of which will range from 1.10 to 1.20 specific gravity, according to the percentage of free fatty acids present and the practice of the individual refiner. The agitation is effected by mechanical stirrers in large tanks provided with heating coils. The quantity of alkaline liquor added is determined by careful laboratory test and run in through perforated pipes. The effect of the alkali is first to darken the oil and apparently thicken it. After a short time small flakes begin to separate and heat is then applied. As the temperature increases, the flakes become larger, owing to the soap softening and running together. When the right point is reached, at temperatures varying from 100 to 130° F., steam and agitation are shut off and the soap drops to the bottom of the kettle, forming a mucilaginous mass, varying in color from yellow to brown through all shades of green and red. This material is known as the "foots." The clear light yellow oil which is pumped off the foots is then refined further for edible purposes. Cotton-seed oil purified in this manner is known to the trade as "summer yellow oil." When used in making lard substitutes it is bleached with fuller's earth and then deodorized, generally by the use of steam. Salad oil is obtained by chilling the summer yellow oil so as to crystallize out the palmitin which is separated by pressing or filtering.

In the United States alone the annual production of cotton-seed foots amounts to approximately half a million barrels valued at two million dollars. The foots vary in gravity from 0.97 to 1.04, averaging about 1.00. They contain the soda salts of the coloring matter, the soda soaps of any free fatty acids present in the cotton-seed oil (30 to 45 per cent) the coagulated albumin (8 to 12 per cent), phytosteryl (see p. 549), and varying quantities of mechanically entrained cotton-seed oil (triglycerides).

Cotton-seed foots are sold on the basis of "50 per cent fatty acid." As a matter of fact they contain between 35 and 65 per cent, averaging about 45 per cent. A representative sample contained:¹

Fatty anhydrides (corresponding to a "50-per cent soap stock")	48.50%
Glycerin	3.98%
Caustic soda (Na ₂ O)	3.20%
Foreign organic matter	5.90%
Coloring matter	2.42%
Water	36.00%
Total	100.00%

The cotton-seed foots may be converted directly into soap by boiling up with a small excess of caustic soda and "salting" it out in the usual manner, when no pitch will be obtained. The resulting soap is known as "killed foots" and the dark lye containing the coloring matter and impurities is run to waste. A process has also been described for recovering a shellac-like substance from cotton-seed foots by oxidizing with hydrogen peroxide in an alkaline solution and acidifying to separate the fatty matter.²

Usually, however, the cotton-seed foots are subjected to distillation. They are first acidified while hot with dilute sulphuric acid, whereupon a "black grease" containing about 90 per cent of the total fatty acids (calculated as oleic) rises to the surface. This is separated and subjected to the Twitchell or other hydrolyzing processes to break up any neutral fat and recover all the glycerin. The fatty acids obtained in this manner are equivalent to 7.5 to 8.5 per cent of the original weight of the cotton-seed oil used. They are subjected to vacuum distillation with superheated steam to separate the pure fatty acids from the residue of fatty-acid pitch, variously called "cotton pitch," "cotton-oil pitch," "cotton-seed-oil pitch," "cotton-stearin pitch," "cotton-seed-oil-foots pitch," etc. The quantity of pitch produced will range between 10 and 20 per cent of the weight of the crude fatty acids (black grease) distilled, which is equivalent to 1 to 2 per cent by weight of the original cotton-seed oil. The yield will depend upon the degree the oil is saponified, the amount of impurities present, the efficiency of the distilling apparatus and the extent to which the distillation is carried.

The purified fatty acids recovered by distillation are used for manufacturing soaps. The fatty-acid pitch is usually soft in consistency, moderately stringy and of a pale brown color when examined by transmitted light in thin layers.

¹ David Wesson, *J. Soc. Chem. Ind.*, **26**, 595, 1907.

² Ger. Pat. 220,582 of Jun. 26, 1909, to Hermann Loeschigk.

(b) *Refining Corn Oil.* Corn oil is sometimes refined by treating with a small proportion of caustic soda in a manner similar to the method described for cotton-seed oil. Upon deodorizing the refined product with superheated steam under reduced pressure, while heated to a temperature of 400° F., an edible product is obtained, used as a salad oil, also for cake and biscuit making. It may also be converted into a lard compound by a hydrogenation process. The corn-oil foots are treated by a method similar to the one used for refining cotton-seed foots. A pitch is obtained known as "corn-oil pitch," possessing a comparatively high fusing-point, characterized by its rubber-like properties and lack of ductility. If the distillation is carried too far, the pitch will actually solidify in the still and can only be removed with great difficulty.

Refining Refuse Greases. (a) *Refining Packing-house and Carcass-rendering Greases.* "Tallow" is the name applied to the purified solid fat or "suet" obtained from cattle. It is used extensively for producing soap and candle stock. The crude fat is first "rendered" by boiling with water in an open vessel to separate it from any albuminous matter or other impurities present, and then clarified by washing with weak brine. "Lard" is obtained by rendering the soft fats which surround the kidneys, intestines and backs of pigs. Tallow and lard may be used as such for manufacturing soaps, but for producing candles they must first be hydrolyzed and purified by steam-distillation.

The waste meat scraps obtained from packing houses, also the carcasses of animals freed from the bones, are treated with steam in large digestors at a high pressure to separate the fat. When the cooking is complete, the batch is allowed to stand quietly to permit the grease to rise to the surface and the disintegrated meat-fibres to settle. The grease is skimmed off and mixed with any additional grease recovered from the settlings by filter-pressing. The residue is then converted into fertilizer, and the aqueous liquid used for making glue. The grease recovered from this process has a disagreeable odor and a dark color, and must be hydrolyzed and steam-distilled before it can be used for manufacturing either candles or soap. The residue from the steam distillation process amounting to between 5 and 6 per cent of the grease, constitutes a variety of fatty-acid pitch having a light brown color when viewed in a thin layer and great ductility (unless the pitch is distilled too far). A packing-house grease has been extensively marketed in this country under the name of "yellow grease."

(b) *Refining Bone Grease.* The bones recovered from packing houses or carcass-rendering works are used for manufacturing glue, bone-black (used for decolorizing petroleum distillates, see p. 308), and fertilizer. Bones from the head, ribs and shoulder-blades contain 12 to 13 per cent of fat, whereas the large thigh bones ("marrows") contain 20 per cent. The fat is extracted by breaking up the bones into small fragments and then either:

(1) Treating with steam in an autoclave under a pressure of 2 to 3 atmospheres, whereupon a portion of the fat separates and floats to the surface, the gelatin or glue goes into solution, and the mineral ingredients (calcium phosphate, etc.) remain as residue. From 8 to 9 per cent of fat (based on the dry weight of the bones) is recovered in this manner.

(2) Extracting the dried bones with a volatile solvent such as benzine, carbon tetrachloride, or benzol in a suitable apparatus. A much larger percentage of fat is extracted in this manner, but the cost of operation is higher, due to unavoidable losses of solvent, and the odor of the product is very strong.

In either event the extracted bone fat is first hydrolyzed by any of the foregoing methods and then steam-distilled, whereupon a variety of fatty-acid pitch, known as "bone-fat pitch" is recovered as residue, amounting to 5 to 6 per cent by weight of the bone-fat. The product may be used for manufacturing soap, or after cooling and filtering, the "stearin" may be converted into candles, and the "olein" either used for manufacturing soap or else marketed as such for "wool oils."

(c) *Refining Garbage and Sewage Greases.* The average city garbage as collected contains:

Water.....	70-80%
Grease.....	3- 4%
Tankage.....	10-20%
Tailings (rubbish).....	3- 6%

It is treated in a manner similar to that used for working up the refuse from packing houses and carcass-rendering establishments, namely by boiling in large digestors holding 8 tons for six hours under a pressure of 70 to 80 lb. (Arnold-Egerton System).¹ This reduces the material to a pulpy mass, which is filter-pressed to remove the water and grease. The residue, known as "tankage," is dried and ground for use as fertilizer. The filtrate is allowed to stand, whereupon the grease rises to the surface and is skimmed off. The grease when dehydrated, has a dark brown color. It is hydrolyzed to separate the glycerin, and the resulting fatty acids purified by steam-distillation to render them suitable for manufacturing soaps and candles. The residue, known as "garbage pitch," amounting to 5 to 7 per cent by weight of the garbage, has a dark color when viewed in a thin layer, and is quite susceptible to temperature changes.

Sewage also carries a proportion of grease which is now often being recovered, especially in large cities. The sewage is first run into large tanks, where the solid matter known as "sludge" settles to the bottom. The precipitation may be accelerated by adding a small percentage of slaked lime. After drawing off the liquor, the sludge is treated with a small quantity of sulphuric acid to break up any insoluble soaps, and then boiled in large digestors under pressure to hydrolyze the fats, and enable the grease to separate. The residue is dried and used as fertilizer. The grease is dehydrated, then hydrolyzed and finally distilled with superheated steam, yielding about 25 per cent of a fatty-acid pitch known as "sewage pitch." The characteristics of this are similar to those of garbage pitch. The distillate contains about 50 per cent of liquid olein and 50 per cent of solid stearin melting at about 113° F.²

(d) *Refining Woolen-mill Waste.* Olive oil, lard oil, neat's-foot oil, saponification olein (or saponified olein) and distillation olein (or distilled olein) are sold under the names "wool oils" or "cloth oils," and used in woolen mills for lubricating the wool before spinning into yarn, or for oiling old woolen rags before grinding and "pulling" in the manufacture of "shoddy." One of the perquisites of the wool oils is that they shall have no tendency to dry or oxidize, and they must also be

¹ "City Refuse and its Disposal," H. de B. Parsons, *J. Soc. Chem. Ind.*, **27**, 376, 1908; "Collection and Final Disposition of City Wastes by the New York Department of Street Cleaning," Edward D. Very, *J. Soc. Chem., Ind.*, **27**, 378, 1908; "Garbage and Rubbish Disposal in Los Angeles," by S. B. Simons, *Munic. J.*, **38**, 799, 1915.

² "The Utilization of Sludge from Town Sewage as a Source of Fat," D. Holde, *Seifensieder-Ztg.*, **41**, 1151, 1915.

easily removable on boiling the finished woolen goods or shoddy with a solution of soap or sodium carbonate. The presence of hydrocarbons, even in small quantities is objectionable, as they tend to prevent the removal of the wool oils during the scouring process.

After the goods are scoured, the liquid is mixed with freshly slaked lime which serves to precipitate the soaps. The curds are settled out and separated, then acidified with dilute sulphuric acid to separate the free fatty acids, which are skimmed off and filtered to remove any dirt. The product known as "fuller's grease," "seek oil," or "magma oil," is distilled with steam, whereby the wool oils are recovered, and a residue of fatty-acid pitch obtained, amounting to 10 per cent by weight of the grease; known as "fuller's-grease pitch," or "seek-oil pitch." This will vary in its properties depending upon the raw materials entering into the composition of the original wool oils.

Treatment of Wool Grease. Wool grease, known also as "wool wax," or "wool dégras" represents the oily material naturally present in sheep's wool, and differs entirely from the so-called "wool oil" discussed previously. Wool grease is in reality an animal wax, as it contains no glycerin or glycerides whatsoever. It is extracted by boiling the cut wool with an alkaline soap solution or sodium carbonate. Formerly volatile solvents were used for this purpose, but the method is no longer practiced. After boiling with soap or sodium carbonate, the liquor is acidified with sulphuric acid, whereupon the grease rises to the surface and is skimmed off. Dehydrated wool grease melts between 86 and 104° F. and contains approximately 55-60 per cent fatty acids, also 40-45 per cent higher alcohols (unsaponifiable).

Wool grease is treated in various ways, and among others by a direct process of distillation with superheated steam *without* previous hydrolysis¹ (as the waxes present are not amenable to such treatment) whereby the following portions are recovered:

(1) A light oil composed mainly of hydrocarbons.

(2) A heavier oil which on cooling separates into a liquid and a solid portion. This is thereupon cooled and filter-pressed to separate the olein (known as "distilled-grease-olein" or "dégras oil"), which is used as a leather or wool oil, from the stearin (known as "dégras stearin"), which is used in the soap industry or as a leather "stuffing grease." The olein consists of 50 per cent free fatty acids and 50 per cent unsaturated hydrocarbons and cholesterol. The stearin carries 70 per cent cholesterol and 30 per cent free fatty acids.

(3) A residue of fatty-acid pitch known specifically as "wool-grease pitch," "wool-fat pitch," "wool pitch" or "cholesterol pitch." The pitch is distinguished by its high ductility and susceptibility factor, the large proportion of unsaponifiable constituents present and the fact that it yields a decided cholesterol reaction (see page 549).

The yields are approximately 10 per cent light oil, 50 per cent olein, 30 per cent stearin and 10 per cent fatty-acid pitch.

The reactions which take place during its distillation are quite complicated. Some of the esters break up into free fatty acids and hydrocarbons thus:

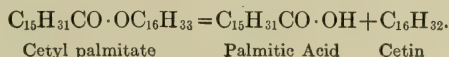

¹ U. S. Pat. 896,093 of Aug. 18, 1908, to Carleton Ellis.

Similarly the higher alcohols and cholesterol distil partly as such and also partly decompose into hydrocarbons.¹

Physical and Chemical Properties of Fatty acid Pitches. Fatty-acid pitches vary considerably in their physical and chemical properties, depending upon the following circumstances:

(1) The nature of the fat or oil from which the fatty acids are derived. If these contain low melting-point fatty acids, the fatty-acid pitch will be soft in consistency, provided the distillation has not been carried too far (see p. 320). On the other hand if high-melting point fatty acids predominate, the fatty-acid pitch will be semi-solid to solid in consistency.

(2) The proportion of neutral fats or oils present in the fatty-acid mixture, which will prove to be the case if the process of hydrolysis is not carried to theoretical completion. Since the neutral fats or oils (triglycerides) do not distil with superheated steam, they concentrate in the fatty-acid pitch, and are very apt to decompose into hydrocarbons (unsaponifiable) if the distillation is carried too far (see p. 319). If the distillation is stopped at a point without decomposing the neutral fats or oils, the value of the fatty-acid pitch is enhanced by their presence, as they are more stable and weather-resistant than the fatty-acids themselves.

(3) The extent to which the distillation is carried and the temperature at which it is performed. If distilled too far or at too high a temperature, the fatty acids decompose in the presence of steam, first into hydroxy acids, which in turn break down into lactides, unsaturated products and lactones in the following manner:

(a) α -hydroxy acids are converted into lactides in accordance with the following reaction:

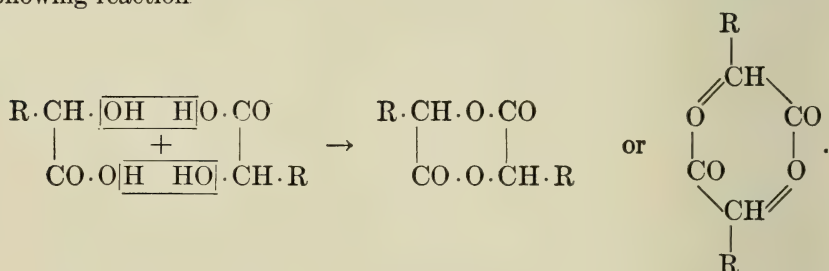

(b) β -hydroxy acids become converted into unsaturated products as follows:

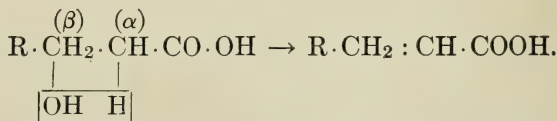

¹ Donath and Margosches, *Chem. Rev. Fett-Harz-Ind.*, **12**, 194, 1904; *Chem. Ind.*, **27**, 220, 1904.

(c) γ and δ hydroxy acids are transposed into cyclic esters of the nature of γ and δ lactones respectively, in the following manner:

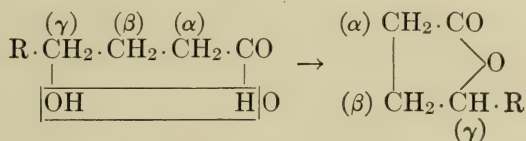

and

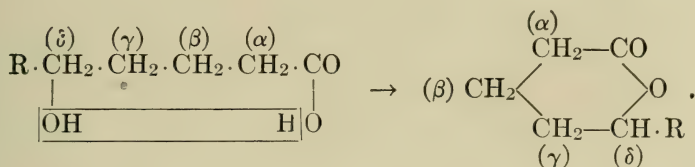

It follows therefore that the fatty-acid pitches contain free fatty acids, their lactones (anhydrides), undecomposed glycerides (neutral fats or oils), condensation products of unknown composition, hydrocarbon decomposition products; and in the case of fatty-acid pitches derived from wool grease, we find cholesterol and higher alcohols.¹

The presence of hydrocarbon decomposition products is evidenced largely by the color of the pitch when examined in a thin layer. If these are present, the pitch will be a black, otherwise it will have a rich brown color. The percentage of saponifiable constituents present in the fatty-acid pitch is a criterion of its quality. The larger the percentage, the better the quality from the standpoint of weather-resistance. Fatty-acid pitches of the optimum quality contain not less than 90 per cent of saponifiable constituents. *They are as weather resistant as any bituminous substance.* The smaller the percentage of saponifiable constituents in the pitch, the less weather-resistant it will prove to be.

In recent years there has been a tendency to remove more and more of the saponifiable ingredients from the fatty-acid pitches, in view of the high price commanded by the fatty acids, and also because of improvements effected in the distillation process. The author has examined fatty-acid

¹ "Stearin Pech," by E. Donath and R. Strasser, *Chem. Zeit.*, **17**, 1788, 1893; "Die Unterscheidung und chemische Natur von dunkeln pechartigen Rückständen der Distillation von Erdölen, Fetten und Fettsäuren," D. Holde and J. Marcusson, *Mitth. königl. techn. Versuchanst. von Berlin*, **18**, 147, 1900, also *Chem. Rev. Fett-Harz-Ind.*, **7**, 2, 1900; "Zur Unterscheidung der Asphalte," B. M. Margosches, *Chem. Rev. Fett-Harz-Ind.*, **11**, 148, 1904; "Examination of Pitches," by E. Donath and B. M. Margosches, *Chem. Ind.*, **27**, 220, 1904; "Notizen über Stearinpeche," E. Donath, *Chem. Rev. Fett-Harz-Ind.*, **12**, 42, also 73, 1905; "Untersuchung der Kohlenwasserstofföle und Fette," D. Holde, Berlin, p. 281, 1913; "Detection of Petroleum Pitch in Fat Distillation Residues," J. Marcusson, *Mitt. kgl. Materialprüfungsamt*, **30**, 186, 1913; "Stearin Pitch," by H. Mayer, *Seifensieder Z.*, **41**, 394, 1914; "Chemical Technology and Analysis of Oils, Fats and Waxes," by Dr. J. Lewkowitzsch, 5th Edition, London, 1915.

pitches containing as high as 98 per cent unsaponifiable constituents. These appear glossy black in color and almost opaque in a thin layer, and therefore find a ready use in the manufacture of cheap lacquers and japans, not intended for exposure out of doors.

All fatty-acid pitches are converted in a more or less *infusible* and *insoluble* mass upon exposure to the weather for a long period, or upon heating a short time to a temperature of 250 to 350° C. in contact with air. This is equally true whether or not unsaponifiable constituents are present, and makes this class of pitches especially valuable for manufacturing, baking japans and varnishes.¹ They are also converted into insoluble and infusible substances by heating with sulphur.² Blowing with air at high temperatures rapidly increases their fusing-point and at the same time tends to convert them into the insoluble modification.³

Fatty-acid pitches containing a large proportion of saponifiable constituents show an extremely *low* susceptibility factor, in fact lower than any other class of bituminous materials. Conversely fatty-acid pitches in which the unsaponifiable constituents predominate are apt to have quite a high susceptibility factor.

In general, the various classes of fatty-acid pitch are characterized by the following predominating *physical* properties, assuming that they have been carefully prepared and neither overheated nor distilled too far, viz.:

Fatty-acid pitches made from lard are usually very ductile with a low susceptibility factor.

Fatty-acid pitches made from tallow are generally hard, lacking in ductility with a low susceptibility factor.

Palm oil pitches are hard, lacking in ductility, with a moderately high susceptibility factor.

Cotton-seed-foots pitch is usually soft, of moderate ductility having a low susceptibility factor.

Corn-oil-foots pitch is *extremely* rubbery, shows little ductility and has an *exceedingly* low susceptibility factor.

Packing-house pitch is ductile and has a low susceptibility factor.

Bone-fat pitch lacks ductility and has a moderately high susceptibility factor. Its color in a thin layer and streak are black.

Garbage and sewage pitches are ductile with a high susceptibility factor. Their color in a thin layer and streak are usually black.

Wool-grease pitch is ductile and has an extremely high susceptibility factor. Its color in a thin layer and streak are usually black.

¹ U. S. Pat. 842,615 of Jan. 29, 1907, to Paul Bœrche; Ger. Pat. 217,026 of 1905 to Vogelsang; also Eng. Pat. 3345 of 1906 to Connolly.

² U. S. Pats. to Griscom, p. 295; also Ger. Pats. 77,810 to L. Bäärnhelm and A. Jernander; 225,911 to Malchow.

³ Ger. Pat. 208,378 of Sept. 13, 1905, to Otto Schreiber.

Fatty-acid pitches (referring to all types) comply with the following characteristics:

(Test 1)	Color in mass.....	Dark brown to black
(Test 1a)	Homogeneity to the eye at 77° F.....	Uniform to gritty
(Test 2b)	Homogeneity under microscope.....	Uniform to lumpy
(Test 3)	Appearance surface aged indoors one week	Bright
(Test 4)	Fracture.....	None to conchoidal
(Test 5)	Lustre.....	Bright
(Test 6)	Streak on porcelain.....	Light yellow, brown to black
(Test 7)	Specific gravity at 77° F.....	0.90-1.10
(Test 9c)	Consistency at 77° F.....	0-40
(Test 9d)	Susceptibility factor.....	8-40
(Test 10)	Ductility.....	Variable
(Test 13)	Odor on heating.....	Characteristic: "fatty"

NOTE. If heated with powdered potassium bisulphate, an odor of acroelin will be evolved due to the decomposition of the glycerin present.

(Test 15a)	Fusing-point (K. and S. method).....	35-225° F.
(Test 15b)	Fusing-point (B. and R. method).....	50-245° F.
(Test 16)	Volatile matter 500° F., 4 hrs.....	0.5-7.5%

NOTE. In nearly all cases, a skin will form over the surface of the pitch during the determination of the volatile matter. This is characteristic. Certain fatty-acid pitches, especially those containing a large percentage of saponifiable constituents, often toughen up and solidify to a rubber-like mass during this test.

(Test 17a)	Flash-point.....	450-650° F.
(Test 19)	Fixed carbon.....	5-35%
(Test 21a)	Solubility in carbon disulphide.....	95-100%
(Test 21b)	Non-mineral matter insoluble.....	0-5%
(Test 21c)	Mineral matter.....	0-5%
(Test 22)	Carbenes.....	0-5%
(Test 23)	Solubility in 88° naphtha.....	80-100%
(Test 28)	Sulphur.....	0%
(Test 30)	Oxygen.....	2-10%
(Test 33)	Paraffine.....	Trace
(Test 34)	Saturated hydrocarbons.....	0-5%
(Test 35)	Sulphonation residue.....	0-5%
(Test 37)	Saponifiable constituents.....	5-98%
(Test 37a)	Acid value (including lactone value).....	2-100
(Test 37b)	Ester value.....	40-125
(Test 37d)	Saponification value.....	60-200
(Test 39)	Unsaponifiable matter.....	2-95%
(Test 39a)	Hydrocarbons in unsaponifiable matter...	90-100%
(Test 39b)	Higher alcohols (cholesterol) in unsaponifiable matter.....	0-10%
(Test 40)	Glycerol.....	Trace-2.5%
(Test 41)	Diazo reaction.....	No
(Test 42)	Anthraquinone reaction.....	No
(Test 43)	Liebermann-Storch reaction.....	Yes in the case of the wool grease pitches <i>only</i>

Table XXVIII contains the results of the examination of representative samples of fatty-acid pitch by the author:

TABLE XXVIII.—CHARACTERISTICS OF

No.	Test.	From Lard.		
<i>Physical Characteristics:</i>				
2a	Homogeneity to eye at 77° F.....	Homog.	Homog.	Homog.
2b	Homogeneity under microscope.....	Homog.	Homog.	Lumpy
3	Appearance surface aged seven days.....	Bright	Bright	Bright
4	Fracture.....
5	Lustre.....
6	Streak.....	Yellow	Yellow	Yellow
7	Specific gravity at 77° F.....	0.972	0.980	0.990
9c	Consistency at 115° F.....	0.0	0.0	0.0
	Consistency at 77° F.....	0.7	1.3	2.4
	Consistency at 32° F.....	8.2	9.8	10.0
9d	Susceptibility factor.....	18.3	16.7	14.3
10b	Ductility in cms. at 115° F.....	0	0	10
	Ductility in cms. at 77° F.....	42	36	25.5
	Ductility in cms. at 32° F.....	75	88	27
11	Tensile strength in kg. at 115° F.....	0.0	0.0	0.0
	Tensile strength in kg. at 77° F.....	0.0	0.05	0.05
	Tensile strength in kg. at 32° F.....	0.75	0.95	1.75
<i>Heat Tests:</i>				
13	Odor on heating.....	Fatty	Fatty	Fatty
15a	Fusing-point deg. F. by K. and S. method.....	44.5	59	70
15b	Fusing-point deg. F. by B. and R. method.....	57	74	85
16	Volatile 500° F. in four hours, per cent.....	2.6	3.0	5.3
	Character of residue.....	Little Change	Little Change	Gelat
17a	Flash-point deg. F.....	452	525	485.5
19	Fixed carbon, per cent.....	6.2	11.2	10.4
<i>Solubility Tests:</i>				
21a	Soluble in carbon disulphide.....	100.0	100.0	99.7
21b	Non-mineral matter insoluble.....	0.0	0.0	0.3
21c	Mineral matter.....	0.4	1.4	1.5
22	Carbenes.....	0.0	0.0	0.0
23	Soluble in 88° naphtha.....	100.0	100.0	100.0
<i>Chemical Tests:</i>				
28	Sulphur.....	0.0
33	Paraffine.....	0.0	0.0	0.0
35	Sulphonation residue.....	0.0	0.3	0.0
37a	Acid value.....	17.6	65.0	63.3
37b	Lactone value.....	63.2	79.8	75.9
37c	Ester value.....	86.4		
37d	Saponification value.....	167.2	144.8	139.2
39	Unsaponifiable matter.....	0.5	5.5	1.5
39a	Hydrocarbons in unsaponifiable matter.....	95.0
39b	Higher alcohols in unsaponifiable matter.....	5.0
40	Glycerol.....	4.7

TYPICAL FATTY-ACID PITCHES.

	From Tallow.	From Packing House Refuse.	From Bone-fat.	From Garbage.	From Sewage.	From Cottonseed-oil Foots.		From Corn Oil Foots.	From Palm-oil.		From Wool-grease.
Homog. Homog. Bright	Homog. Bright	Homog. Bright	Homog. Gritty Bright	Homog. Gritty Bright	Gritty Lumpy Bright	Homog. Lumpy Bright	Homog. Bright	Gritty Lumpy Bright	Homog. Dull Conch.	Homog. Gritty Bright Conch.	Gritty Lumpy Bright
.....	Bright
Brown	Brown	Brown	Black	Black	Black	Yellow	Brown	Brown	Sl. dull	Bright	Black
1.000	1.060	1.003	1.036	1.063	1.011	0.992	0.955	0.998	1.042	1.087	1.020
1.5	11.3	0.6	2.4	2.6	2.9	0.0	1.1	7.2	9.3	11.7	0.0
5.8	23.2	6.3	7.9	11.7	30.0	2.7	5.1	15.8	24.7	35.2	4.2
15.2	52.0	15.7	55.4	60.1	48.3	14.1	16.5	25.1	56.5	82.0	32.8
12.5	22.3	15.6	41.9	40.5	33.9	19.7	15.3	8.5	29.5	41.0	35.8
2.5	18.5	23.	18.	72.5	52.	8.5	31.	5.	35.5	25.	15.
28.5	4.	81.5	5.	60.	15.	19.	26.5	2.	2.	0.5	47.5
18.	0.	20.	0.	0.	0.5	28.5	10.	0.5	0.	0	31
0.05	1.75	0.0	0.05	0.50	0.25	0.0	0.05	0.75	1.00	2.20	0.0
0.20	3.10	0.40	0.30	1.25	1.10	0.10	0.5	1.55	2.2	5.00	0.25
2.35	6.2	3.25	4.70	6.2	8.0	2.30	4.2	5.4	9.5	11.25	1.05
Fatty 110	Fatty 182	Fatty 97 126.5 142	Fatty 134	Fatty 71.5	Fatty 101	Fatty 210	Fatty 161.5	Fatty 172	Fatty 91.5
130	202	115	144	162	151.5	92	120	235.5	186	193	108.5
5.0	1.2	1.7	0.5	0.6	0.55	4.2	0.38	0.25	3.5	1.2	7.2
Little Change	Little Change	Little Change	Little Change	Gelat. Change	Gelat.	Gelat.	Gelat.	Gelat.	Much Change	Little Change	Little Change
486	482	510	575	590	540	635	525	580	462	504	460
12.0	18.4	12.6	19.4	33.5	18.3	10.8	9.2	8.2	26.2	34.0	30.6
100.0	98.5	100.0	97.7	98.2	98.2	99.8	97.5	97.3	98.2	96.2	98.8
0.0	2.1	0.0	0.0	0.7	1.7	0.2	0.4	2.0	0.8	3.8	0.5
0.5	1.3	2.0	0.3	0.35	0.8	1.4	0.3	0.5	1.2	1.3	1.1
0.0	0.1	0.0	0.1	0.4	1.1	0.0	0.0	0.2	2.1	4.3	0.0
98.0	86.7	100.0	94.6	88.3	95.2	100.0	92.1	96.4	92.0	82.2	99.0
.....	0.0	0.0	0.0	0.0	0.0
0.0	0.0	0.0	0.0	0.0	0.1	0.0	0.0	0.0	0.2	0.3	0.0
.....	3.7	4.0	3.0	0.0	0.5	1.2
81.95	44.1	23.5	20.2	2.5	60.5	46.5	13.4	36.5
97.55	112.0	74.1	39.5	103.5	95.4	92.9	53.9	88.7
179.5	156.1	97.6	59.7	106.0	120.4	155.9	151.0	172.0	139.4	67.3	125.2
1.0	15.2	5.0	98.0	97.0	7.0	2.0	4.6	2.7	6.0	75.0	60.6
.....	97.0	93.6	91.7	90.5	95.0	96.0	90.0
.....	3.0	6.4	8.3	9.5	5.0	4.0	10.0
.....	0.0	0.55	0.8	2.35

According to Marcusson¹ the saponification value of fatty-acid pitches never runs below 33, and in the majority of cases exceeds 100, whereas the saponification value of petroleum asphalts does not exceed 21. A. R. Lukens² reports that the saponification value of fatty-acid pitches ranges from 45 to 100, and in the case of petroleum asphalts from 5 to 18.

Fatty-acid pitches are also distinguished from asphalts by the small percentage of sulphonation residue, and the absence of sulphur.

According to Donath and Margosches (loc. cit.) wool-grease pitch may be identified by boiling the material with alcoholic potash, and then filtering the hot liquid. A fairly abundant precipitate will form in the filtrate on cooling, which will give the cholesterol reaction. (Test 43.)

The author has found the lineal coefficient of expansion of fatty-acid pitches for 1° F. (length=1) to average 0.00023.

Fatty-acid pitches flux satisfactorily with mineral waxes, native and pyrogenous asphalts, tars and pitches. They also flux satisfactorily with gilsonite and glance pitch, but *not* with grahamite.

The following figures indicate that the hardening (toughening) of fatty-acid pitches on exposure to the weather is due to *oxidation*. A sample of soft fatty-acid pitch (the first in Table XXVIII) was melted and poured into a shallow glass dish, forming a layer *exactly* 1 millimeter thick. This was exposed out of doors for one year in a dust-free receptacle protected from the direct action of the weather, and the following increases in weight noted:

After 1 month gained	0.62%	After 7 months gained	4.20%
2	2.52%	8	4.27%
3	3.27%	9	4.30%
4	3.50%	10	4.38%
5	3.86%	11	4.42%
6	4.12%	12	4.46%

The original pitch was soft and semi-liquid, but after exposure for one year it hardened to a tough, leathery mass. The original fusing-point was 44½° F. (K. and S. method), and at the end of the year 185° F.

BONE TAR AND BONE-TAR PITCH

In the production of bone tar and bone-tar pitch the crude bones are first steeped in a 1 per cent solution of brine for three to four days, to separate the fibrous matter. They are then degreased by one of the following methods:

- (1) Boiling the bones with water in open vessels;
- (2) Boiling with water in closed tanks under a pressure of 10 lb.;
- (3) Extracting the bones with a solvent (usually a petroleum distillate boiling at 100° C.) and removing the last traces of solvent from the bones

¹"The Composition and Examination of Residues Obtained from Fat Distillation," *Z. angew. Chem.*, **24**, 1297, 1911.

²"Distinguishing between Petroleum Residuums and the Various Fat Pitches," *The Chemist-Analyst*, **20**, 3, 1917.

by blowing in live steam. The degreased bones are then treated to extract the glue by again subjecting the bones to the action of live steam for a lengthy period under a pressure of 15 to 20 lb. in an upright cylindrical boiler with a false bottom. The glue gradually leaches from the bones, the quantity extracted depending upon the duration of the treatment. When it is desired to convert the bones into "bone charcoal" (used for the purification of petroleum distillates and paraffine wax, as described on p. 308), only one-half of the gelatinous matter is extracted from the degreased bones, whereupon the water is drained off and the bones allowed to air-dry. They are then distilled destructively in horizontal cast-iron retorts, the distillate being condensed, and the permanent gases consumed under the retort. The distillate consists of an alkaline aqueous liquor containing ammoniacal bodies, and a tarry layer known as "bone tar," "bone oil" or "Dippel oil." The residue remaining in the retort, known as "bone charcoal" or "animal charcoal" is removed while still hot, and transferred to an air-tight vessel in which it is allowed to cool. It is then passed through grinding mills and sieved. The bone charcoal is composed of approximately 10 per cent of carbon, 75 per cent of calcium phosphate, the balance consisting of various other mineral ingredients and moisture.

The following yields are obtained:

Non-condensable gases.....	10-15%
Aqueous liquor.....	10-15%
Bone-tar.....	25-10%
Bone charcoal.....	55-60%
<hr/>	
Total.....	100-100%

The bone tar floating on the surface of the aqueous liquor is drawn off. It consists of fatty substances derived from the fat which escaped extraction from the bones, also derivatives of pyridine possessing a most disagreeable and penetrating odor, and incidentally serving to distinguish it from all other tars. The characteristics of bone tar are included in Table XXXV, page 482.

The aqueous liquor is distilled, and the distillate caught in sulphuric acid to recover the ammonium compounds as ammonium sulphate. The residue is used as a fertilizer.

The bone tar is subjected to fractional distillation to recover the bone-tar pitch, the properties of which are also embodied in Table XXXV, page 482.

Bone-tar pitch is intermediate in its physical properties between asphalts and the fatty-acid pitches. It is moderately susceptible to temperature changes, and on a par with higher grades of residual asphalts and inferior grades of fatty-acid pitches in its weather-resisting properties.

It is produced in comparatively small quantities and cannot therefore be regarded as a commercial product.

PART IV

MANUFACTURED PRODUCTS AND THEIR USES

CHAPTER XXIII

METHODS OF BLENDING

ONE of the most important questions which confronts the bitumenologist is that of blending the various substances at his disposal, to produce mixtures best adapted for the special purposes for which they are intended. This requires an intimate knowledge of the nature and behavior of the various materials, and can only be thoroughly acquired by years of experience. Two shipments of any given member of the bituminous family are likely to fluctuate widely in their physical properties and composition, even when procured from the identical source. A native bituminous substance emanating from the *same* deposit will vary, depending upon the degree of exposure and amount of metamorphosis. It has been shown that all native bituminous materials are in a constant state of transition, depending upon their age and environment. Scarcely any two deposits of native asphalt are alike in their properties or chemical composition. The same applies to petroleum, which varies in different localities and very often in wells side by side in the same field.

The pyrogenous bituminous materials also show a marked variation in their properties, depending upon the raw materials used in their production and the exact conditions to which they have been subjected in their process of manufacture, including the temperature, length of treatment, etc.

Bituminous materials should not therefore be compared to vegetable and animal fats or oils, which in the case of any one material runs fairly uniform in composition and physical properties.

The consistency of the available *raw* bituminous materials is either fixed and definite, or it is controllable. All native bituminous substances have a predetermined consistency—in other words they are endowed by

nature with certain fixed and definite physical properties, and over which man has no control. On the other hand, the consistency of pyrogenous bituminous substances, with three exceptions (i.e., wax tailings, tars and rosin pitch), is largely controllable, and depends upon the treatment to which they are subjected in the course of their production. In the majority of pyrogenous substances, it is a comparatively easy matter to alter their consistency at will, by regulating the duration of the process, its temperature, or some other condition. In the three exceptions noted, the consistency is predetermined, and has no definite bearing upon the variable functions of the process.

Table XXIX will serve to give a general idea whether the hardness and fusibility of the various bituminous substances are definite or controllable, whether the substances are naturally soft, medium or hard at room temperature; also their approximate comparative volatility, weather-proof properties, and efficiency in fluxing.

In interpreting Table XXIX, it should be distinctly noted that the "Hardness at Room Temperature," "Volatility," "Weatherproof Properties" and "Efficiency in Fluxing" are listed in a *comparative* sense, and must not therefore be regarded as a definite exposition of the characteristics of any *single* substance, without taking into consideration the others cited.

In addition to the bituminous substances, there are included three groups of non-bituminous substances commonly used for purposes of blending; viz., rosin, animal and vegetable oils and fats, and wool grease.

In preparing mixtures of bituminous materials, the following points should be borne in mind:

(1) Bituminous materials which give the diazo reaction (Test 41), (containing phenols), should not be mixed with bituminous substances not giving this reaction. In other words, native asphalts, asphaltites and pyrogenous asphalts should not be blended with tars or pitches (excepting fatty-acid pitch), since it has been found by experience that such mixtures, although they may melt together perfectly, are not durable or weather-proof.

(2) Native and pyrogenous waxes will not remain permanently blended with other bituminous materials, but will crystallize at low temperatures, gradually separating from solid mixtures on standing. This manifests itself by the wax "sweating" from the surface. In certain cases this feature is desirable, since the admixture of a small percentage of wax imparts wax-like properties to the entire composition (see p. 347).

(3) Grahamite does not flux with native or pyrogenous waxes, residual oils derived from non-asphaltic petroleum, fatty-acid pitch or wool grease.

TABLE XXIX

	Hardness and Fusibility.	Hardness at 77° F.	Approximate Comparative Volatility.	Approximate Comparative Weatherproof Properties.	Efficiency in Fluxing.	Remarks.
Legend	D: definite.	S: soft.	V: volatile.	H: highly weatherproof.		
	FC: fairly definite but controllable	[<20]*	M: moderately volatile.	W: weatherproof.	G: good.	
	within narrow limits.	M: medium	N: non-volatile.	M: moderately weatherproof.	F: fair.	
	IC: indefinite but controllable.	H: hard		N: non-weatherproof.	P: poor.	
	IN: indefinite and non-controllable.	[>30].*				
BITUMINOUS SUBSTANCES:						
BITUMENS:						
<i>Crude petroleum</i>	D	S	V	N	P	Rarely used for blending.
<i>Native mineral waxes:</i>	FC	M	M to N	M	P	Used for imparting wax-like properties, an unctuous feel, or to lessen the tendency towards stickiness.
Ozokerite.....	D	H	N	M	P	Blend with one another, also with pyrogenous asphalts, asphaltites and fatty-acid pitches.
Montan wax.....	IN	H	V to M to N	W to H to H	G	Used to harden and raise the fusing-point of asphaltic mixtures.
<i>Native asphalts</i>	D	S	M to N	M to W to H	G	Same as for ozokerite and montan wax.
<i>Asphaltites</i>	D	H	N	W to H	G	Excellent flux for all asphaltic substances, but not weatherproof.
PYROGENOUS DISTILLATES:	IC	S	V to M	N to M	P	Rarely used for fluxing.
<i>Pyrogenous waxes</i>	D	M	M to N	M	P	
<i>Wax tailings</i>	D	H	N	N to M	G	
<i>Tars</i>	D	S	V	N	G	
PYROGENOUS RESIDUES:	FC	S	M to N	W to H	P to F	Excellent flux for all asphaltic mixtures, asphaltites † and fatty-acid pitches.
<i>Pyrogenous Asphalts:</i>	FC	S	M to N	W to H	G	Excellent fluxes for all asphaltic materials, all asphaltites and fatty-acid pitches.
Residual oils (from non-asph. crudes)	FC	S	M to N	W to H	G	
Residual oils (from mixed-base crudes)						
Residual oils (from asphaltic crudes)						

† Excepting grahmitite.

* Consistometer hardness at 77° F.

TABLE XXIX—(Continued)

Blown petroleum asphalts.....	FC	{	S	N	W to H	G	Blend readily with asphaltic mixtures, asphaltites and fatty-acid pitches.
Residual asphalts.....	IC	{	M	N	W to H	G	
		{	M	N	W to H	G	
		{	H	N	W	G	
Sludge asphalts.....	IC	{	S	N	N to M	G	
		{	M	N	N to M	G	
Wurtzilite asphalt.....	FC	{	H	N	W to H	G	
		{	M	N	W to H	G	
<i>Pitches:</i>		{	S	V to M	W to H	G	
Wood-tar pitch.....	IC	{	M	M to N	N	G	
Rosin pitch.....	D	{	H	M to N	N	G	Rarely used for fluxing.
		{	H	M to N	N	G	Blend readily with all pitches.
Feat- and lignite-tar pitch.....	IC	{	S	V to M	N to M	G	An excellent flux for all bituminous substances, but not weatherproof.
		{	M	M to N	M	G	Rarely used for fluxing.
Water- and oil-gas-tar pitch.....	IC	{	S	V to M	N to M	G	Blend readily with all pitches.
		{	M	M to N	M	G	Rarely used for fluxing.
Coal-tar pitches.....	IC	{	S	V to M	N to M	G	Blend readily with all pitches.
		{	M	M to N	W	G	Rarely used for fluxing.
Fatty-acid pitch.....	IC	{	S	N	W to H	F to G	Blend readily with all bituminous substances, † also weatherproof.
		{	M	N	W to H	F to G	Rarely used for fluxing.
Bone-tar pitch.....	IC	{	H	V to M	N to M	G	Blend readily with all pitches.
		{	M	M to N	M	G	Excellent flux for all bituminous substances but not weatherproof.
		{	H	N	H	G	Excellent fluxes for all bituminous substances and highly weatherproof.
NON-BITUMINOUS SUBSTANCES:							Fluxes readily with most bituminous substances † and highly weatherproof.
<i>Rosin</i>	D		H	M to N	N	G	
<i>Animal or vegetable oils and fats</i>	D		S	N	H	G	
<i>Wool grease</i>	D		S	N	N	F to G	

† Excepting grahamite.

(4) If the bituminous material contains a percentage of "non-mineral matter insoluble in carbon disulphide" ("free carbon"), the act of fluxing with other bituminous substances, rosin, animal or vegetable oils and fats will only dilute this ingredient, without eliminating it. The calculated proportion will still be present in the mixture.

(5) The percentage of carbenes may be reduced by fluxing or blending, as the carbenes themselves are fluxed by other bituminous substances, rosin, animal or vegetable oils and fats.

(6) The thoroughness with which bituminous materials blend, may be ascertained by finding the fusing-point of the components, and comparing the calculated fusing-point of the mixture with its actual fusing-point. If the actual fusing-point is equal to, or greater than the calculated fusing-point, then the blending has been thorough. On the other hand, if the actual fusing-point is less than the calculated fusing-point, then the components do not amalgamate thoroughly.

(7) The microscopic test may also be used to good advantage to ascertain the thoroughness with which the components blend. A separation of particles in the mixture is evidence that perfect amalgamation does not occur.

Where the hardness and fusibility of the bituminous substance are "controllable," it is often a simple matter to continue the distillation, blowing, depolymerization (in the case of wurtzilite asphalt), etc., until a product is obtained having the desired physical characteristics. Where conditions permit, it is more convenient and economical to turn out a product of *exactly* the proper grade, than to flux or harden it *afterwards*. It is accordingly customary to market residual asphalts of exactly the right hardness and fusing-point for paving purposes, etc. Blown asphalts are similarly marketed in various grades, having different fusing-points (and hardnesses), so that the manufacturer may pick out one best adapted to his particular purpose. Coal-tar is likewise distilled to a predetermined extent to obtain pitches suitable for use as such in connection with waterproofing, roofing work, road purposes or briquette making, whichever the case may be.

Binary Mixtures. It is not always possible to use a single bituminous material, since it is sometimes found that the *exact* characteristics required are lacking, and can only be obtained by blending together two or more substances in suitable proportions. The simplest mixtures, containing two constituents, are known as "binary mixtures." In this case it is a comparatively simple matter to predict what the characteristics of the finished product will be.

The purpose of preparing a *mixture* is to soften the substance and lower

its fusing-point, to harden the substance and raise its fusing-point, to render the mixture less susceptible to temperature changes, effect a more perfect union or blending of the constituents, improve its weatherproof properties, increase the tensile strength, render the mixture wax-like, or unctuous to the feel, lessen the tendency towards stickiness, etc.

Softening the Substance and Lowering its Fusing-point. This process is ordinarily known as "fluxing." When the bituminous material as it occurs naturally or results from a manufacturing process is too hard in consistency or fuses at too high a temperature, it is customary to mix it with a softer substance, termed a "flux," to impart the necessary characteristics. The fluxes may be classified in three groups as follows:

GROUP I. For Softening Asphaltic Materials and Asphaltites.	GROUP II. For Softening Pitches.	GROUP III. Used Indiscriminately for Softening Asphaltic Materi- als, Asphaltites and Pitches.
Soft native asphalt. Residual oils. Soft blown asphalt. Soft residual asphalt. Soft sludge asphalt.	Medium wood-tar pitch. Medium peat- and lignite-tar pitches. Medium water-gas-tar pitch. Medium oil-gas-tar pitch. Medium coal-tar pitch. Medium bone-tar pitch.	Wax tailings. Soft and medium fatty-acid pitches.* Animal and vegetable oils and fats. Wool grease.*

* Not suitable for fluxing grahamite.

The fluxes listed in Group II should not be used for softening asphaltic materials and asphaltites, or those in Group I for softening pitches (excepting rosin- and fatty-acid pitches), for reasons already explained. The fluxes listed in Group III will answer satisfactorily for softening asphaltic products, asphaltites and pitches, without injuring their weather-resisting qualities.

Of Group I fluxes: residual oils, soft blown asphalt and soft residual asphalt are ordinarily used, on account of their weather-resisting properties, their efficiency in fluxing, the absence of volatile constituents and their comparative cheapness.

Of Group II fluxes: water-gas-tar pitch and oil-gas-tar pitch are ordinarily used for preparing "cut-back" coal-tar pitches for use as dust-laying oils, road surfacings, etc., as previously explained (p. 251).

Of Group III fluxes: animal and vegetable oils or fats are most generally employed, owing to their abundance and uniformity. They are only used in *special* cases (e.g. manufacturing certain bituminous paints, varnishes and japans, rubber substitutes, coating compositions for high-grade prepared roofings, etc.), in view of their comparatively high price, although they are without question the fluxes *par excellence* for bituminous materials.

Hardening the Substance and Raising its Fusing-point. Where the bituminous substance is too soft for the purpose intended, it is customary to harden it by adding one or more of the following materials:

GROUP I. For Hardening Asphaltic Materials.	GROUP II. For Hardening Pitches.	GROUP III. May be Used Indiscriminately for Hardening Asphaltic Materials or Pitches.
Hard native asphalt. Asphaltites. Hard residual asphalt. Hard sludge asphalt. Hard wurtzilite asphalt.	Hard wood-tar pitch. Hard peat-and lignite-tar pitches. Hard water-gas-tar pitch. Hard oil-gas-tar pitch. Hard coal-tar pitch. Hard bone-tar pitch.	Rosin pitch. Rosin. Hard fatty-acid pitch. Fillers. Blowing with air. Combining with sulphur.

Of Group I hardeners, hard native asphalts, hard residual asphalts and asphaltites are most frequently used; and similarly of the Group II and Group III hardeners, hard coal-tar pitch and fillers respectively, are most generally employed. The fillers may be of vegetable or mineral origin, and will be discussed in greater detail later. (See p. 393.) It is not customary to harden bituminous mixtures by blowing with air after they are once prepared, although this procedure would increase the hardness and particularly the fusing-point. All bituminous substances may be hardened by heating with a small percentage of sulphur (see p. 294) after the manner of vulcanization in the rubber industry. This is only used to a limited extent, owing to the difficulty of controlling the degree of hardening, also because of the fact that it tends to reduce the ductility of the product.

Rendering the Mixture Less Susceptible to Temperature Changes. It is difficult to lay down any definite rules in this connection. In general, it may be stated that the suitable addition of the following substances will tend to make mixtures more resistant to temperature changes, viz.:

Asphaltites. Blown asphalt.	Wurtzilite asphalt. Fatty-acid pitch.	Animal or vegetable oils and fats. Fillers (mineral and vegetable).
--------------------------------	--	--

The first three, of course, should only be used in connection with asphaltic mixtures, whereas the last three are applicable either to asphaltic mixtures or pitches. Animal or vegetable oils and fats which have been thickened or "boiled" by heating to a high temperature until they polymerize, are more efficient in this respect than oils or fats in their crude state. The effect of mineral fillers is shown in Table XXX (p. 346).

Effecting a More Perfect Union or Blending of the Constituents. At times the components of a bituminous mixture do not amalgamate thoroughly. This is detected by a lack of homogeneity (Test 2), i.e., by distributing the surface and observing whether it becomes duller, or else by drawing out a pellet into a thin thread, and noting whether any dulling occurs. Certain fluxes when combined with the mixture, often in a small proportion, serve to overcome this tendency, and result in a more complete amalgamation of the components. Such fluxes in the approximate order of their efficiency are as follows:

Rosin. Rosin pitch.	Animal or vegetable oils and fats. Wax tailings.
------------------------	---

It will be understood that these fluxes do not influence the percentage of non-mineral matter insoluble in carbon disulphide (free carbon), or any dullness due to this constituent.

Making the Mixture More Weatherproof. This is another question which cannot be decided by any hard and fixed rules, as it depends largely upon what materials are present in the mixture, and how badly it may lack weatherproof qualities. There may be cases where the bituminous substance is so deficient in weatherproof properties that it would be impracticable to attempt improving it, on account of the extremely *large proportion* of material which would have to be added to overcome this defect. In general, it may be stated that the addition of the following products tends to overcome the non-weatherproof properties of bituminous mixtures:

GROUP I. For Augmenting the Weatherproof Properties of Asphaltic Materials Only.	GROUP II. For Augmenting the Weatherproof Properties of Pitches as Well as Asphaltic Materials.
Asphaltites. Certain native asphalts. Certain residual oils. Blown asphalt. Wurtzilite asphalt. Certain fatty-acid pitches.	Animal or vegetable oils and fats. Wool grease. Fillers (mineral <i>only</i>).

Of the products included in Group I, the asphaltites, wurtzilite asphalt and certain fatty acid pitches (of the saponifiable type) will most effectively improve the weather-resisting properties of the mixture, due to the fact that these materials of themselves are highly weatherproof. Among the asphaltites, grahamite is most weather-resisting, gilsonite and glance pitch ranging next in efficiency and being about equal in this respect. Wurtzilite asphalt is extremely weatherproof, and the same also applies to the saponifiable varieties of fatty-acid pitch. Only *certain* native asphalts and residual oils are included in this category, for it is impossible to lay down any definite rules to differentiate between the non-weatherproof and weatherproof varieties, since this can only be determined as the result of experience or by an *actual exposure test*. The physical and chemical tests fail to determine definitely whether a native asphalt or residual oil will display the optimum weather-resistance in actual service. Certain tests (e.g., large percentages of volatile matter and non-mineral constituents insoluble in carbon disulphide), may definitely pronounce the material to be non-weatherproof, but if these, by chance, prove negative, the court of final appeal is an *actual exposure test* under service conditions.

Both fluxes enumerated under Group II are equally efficient from the standpoint of weather-resistance, although the first named is superior in its fluxing properties. Mineral fillers when added in a finely divided state, or in the form of *graded* particles proportioned to show the minimum percentage of voids (p. 363) tend to improve the weather-resistance of all bituminous substances. Those fillers which are impermeable to light are most efficient in this respect (p. 393). The same rules apply in this connection, as with mineral pigments in linseed oil paints.¹

Increasing the Tensile Strength of Bituminous Mixtures. For some purposes it is important that a bituminous mixture shall have the maximum tensile strength,

¹ "Physical Characteristics of a Paint Coating," by R. S. Perry, Am. Inst. of Architects, Michigan Chapter, Jun. 4, 1907.

to enable it to withstand the stresses and strains to which it may be subjected in usage. This is of special importance in the case of certain forms of bituminous pavements. Two general methods are used for the purpose, viz.:

(1) Incorporating mineral fillers.

(2) Increasing the hardness, by blending with harder bituminous substances (p. 343).

The effect of mineral fillers on the physical characteristics is illustrated in the following figures, based on the mixtures of a straight-run residual Mexican asphalt with 0, 15, 30, 45 and 60 per cent of precipitated calcium carbonate.

TABLE XXX

Soft residual asphalt.....	100%	85%	70%	55%	40%
Precipitated calcium carbonate.....	0%	15%	30%	45%	60%
(Test 9c) Consistency at 115° F.....	0.0	0.0	0.0	3.1
Consistency at 77° F.....	3.1	4.6	6.5	13.9
Consistency at 32° F.....	18.4	22.2	24.1	30.4
(Test 9d) Susceptibility factor.....	19.8	22.6	19.5	14.5
(Test 10b) Ductility at 115° F.....	14	13	10	2.5
Ductility at 77° F.....	40	31	13	0.6
Ductility at 32° F.....	2.7	2.6	0.8	0.5
(Test 11) Tensile strength at 115° F.....	0.0	0.0	0.0	0.3
Tensile strength at 77° F.....	0.4	1.1	1.7	2.4
Tensile strength at 32° F.....	5.5	7.5	9.5	13.0
(Test 15a) Fusing-point (K. and S. method)....	93° F.	98° F.	106° F.	163° F.
(Test 15b) Fusing-point (B. and R. method)....	110° F.	115° F.	124° F.	188° F.
Medium residual asphalt.....	100%	85%	70%	55%	40%
Precipitated calcium carbonate.....	0%	15%	30%	45%	60%
(Test 9c) Consistency at 115° F.....	2.1	2.7	5.75	13.6	17.1
Consistency at 77° F.....	10.0	12.4	17.65	26.2	36.6
Consistency at 32° F.....	47.3	51.9	54.3	66.9	80.4
(Test 9d) Susceptibility factor.....	38.2	39.7	35.9	28.0	26.2
(Test 10b) Ductility at 115° F.....	27	22	11	0.8	*
Ductility at 77° F.....	38	13	1.1	0.25	*
Ductility at 32° F.....	0.0	0.2	0.1	0.0	*
(Test 11) Tensile strength at 115° F.....	0.0	0.2	0.8	1.8	*
Tensile strength at 77° F.....	1.6	2.2	4.3	6.7	*
Tensile strength at 32° F.....	9.6	14.0	20.5	27.2	*
(Test 15a) Fusing-point (K. and S. method)....	118° F.	124° F.	135° F.	190° F.	242° F.
(Test 15b) Fusing-point (B. and R. method)....	136° F.	145° F.	158° F.	216° F.	269° F.

* Does not flow when heated.

It will be noted that the fusing-point, hardness, and tensile strength increase, whereas the susceptibility factor and ductility decrease in proportion to the quantity of filler added. When the percentage of filler is sufficient to destroy the fluidity of the mixture, as in the case of the surface course of sheet asphalt pavements (where the filler exceeds 80 per cent by weight), the physical properties of the mixture depend largely upon the pressure to which the mass has been subjected. The greater the compression, the greater will be the hardness, tensile strength and density.

The tensile strength of a soft bituminous mixture increases to a certain point upon being blended with harder bituminous substances, but these have a ten-

dency to reduce the strength, when the mixture reaches the hard and brittle stage (see Table XXVI, p. 300).

Rendering Wax-like, Unctuous to the Feel, or Lessening the Tendency towards Stickiness. For certain purposes, it is desirable to impart the foregoing properties to bituminous mixtures, especially in manufacturing insulating compounds, rubber substitutes, coating compositions for papers, etc. The addition of a small percentage of the following waxes (usually less than 10-15 per cent) will serve to accomplish this result:

Ozokerite.

Montan wax.

Pyrogenous waxes.

These will not amalgamate permanently with bituminous materials, but will work their way to the surface in time, forming a thin waxy film which will modify the characteristics of the mixture, imparting certain of the physical properties of waxes. In the case of ozokerite and pyrogenous waxes only a small percentage should be added, otherwise the separation will be sufficiently great to destroy the integrity of the mixture. Montan wax may be added in large quantities, as it constitutes a better flux and shows but a slight tendency towards separation.

Tertiary and Complex Mixtures. In the case of binary mixtures, the characteristics of the blended product may be predicted with a reasonable degree of certainty, but with tertiary or quaternary mixtures this is extremely difficult, and in many cases impossible to do, even by one highly skilled in the art. We must bear in mind that the native asphalts, for example, occur in hundreds of varieties, each differing in certain respects from the others, or as one authority on the subject aptly expresses it: "No two deposits of native asphalt or petroleum on the face of the earth are exactly alike." Similarly, blown asphalts, residual asphalts, coal-tar pitches, etc., are produced in hundreds of forms, depending upon the nature of the crude materials, the temperature to which they have been subjected, the length of blowing, the duration of the distillation process, and many other factors. These result in the production of a whole series of products from any particular raw material, varying in fusibility, hardness and other physical and chemical characteristics. Since each class of raw material is available in hundreds of varieties, it will be apparent that the number of possible combinations in tertiary mixtures is infinite.

In color matching, a given shade may be produced in a dozen different ways, each starting with totally different colors, and similarly a given bituminous substance may be exactly duplicated in physical characteristics (i.e., fusing-point, hardness, ductility, tensile strength, volatility, etc.), by numerous mixtures, each containing *different* combinations of *different* materials.

The only way to match a given bituminous substance is by the "cut and try method." This applies with more force when it comes to tertiary and complex mixtures. To exactly duplicate a complex bituminous

mixture is one of the most difficult and at the same time one of the most fascinating problems in bituminology. At the present stage of the science, a chemical analysis of the material to be duplicated will tell nothing. It is only an intimate knowledge of the *physical* properties of the available bituminous raw materials, and an inference of their behavior in combinations, that will assist the expert in synthesizing a mixture having substantially the same properties as the one to be duplicated.

The problem is made still more complicated by the fact that although we may apparently succeed in duplicating the *physical properties* of a given bituminous mixture, yet there is no way of telling other than from an *actual* service test whether or not it will behave the same on *aging* or upon *exposure* to the elements. No "accelerated" test is known by which this may be accurately predetermined.

Classes of Bituminous Mixtures. Bituminous substances and their mixtures may be roughly divided into three general classes, characterized by being "soft," "medium" and "hard" at room temperature. The following table will show which of the commercial products belong to the respective classes:

Soft (liquid) Bituminous Products:

- Dust-laying oils.
- Binders for road surfacings.
- Impregnation for wooden paving blocks, railroad ties, etc.
- Tars and oils for the flotation process.
- Saturating compounds for prepared roofing, flooring, waterproofing, sheathing and insulating papers, electrical insulating tape, etc.
- Waterproofing compounds for Portland-cement mortar and concrete.

Medium (semi-liquid to semi-solid) Bituminous Products:

- Binders for bituminous surfacings, bituminous macadam and bituminous concrete pavements.
- Asphaltic cement for sheet asphalt pavements, asphalt-block pavements and asphalt mastic foot-pavements and floors.
- Fillers for wood, brick and stone pavements.
- Bituminous expansion joints.
- Coatings for prepared roofing, flooring, waterproofing, sheathing and insulating papers.
- Adhesive compounds for built-up roofing and waterproofing work; bases of plastic compounds for repairing roofs, etc.
- Pipe-dips and pipe-sealing compounds.
- Electrical insulating compounds.
- Rubber substitutes and fillers.
- Moulding compounds.
- Bases of bituminous paints and cements.

Hard (solid) Bituminous Products:

- Certain forms of electrical insulating compounds.
- Moulding compounds.
- Binders for briquettes.
- Certain forms of pipe dips.
- Bases of varnishes, enamels, japans and certain bituminous paints.

Processes of Blending Bituminous Substances. The types of apparatus for this purpose fall into two groups, viz.:

- (1) Open vessels of semi-cylindrical or rectangular form, as described

for dehydrating semi-solid and solid native bituminous substances (Chapter VI).

(2) Closed horizontal cylindrical vessels provided with an agitator in the form of a horizontal shaft carrying short stout blades or paddles usually set at an angle. This type is mounted on a masonry foundation over a solid or perforated fire-brick arch, and the heating effected by burning coal or gas underneath it. The vessel is provided with a manhole at the top, through which the bituminous substances are changed, and closed with a cap during the melting process to keep out air and prevent the vapors from igniting.

The first type is used where the bituminous substance is heated below the flash-point of the constituent flashing at the lowest temperature, and the second where it is necessary or desirable to heat the mass above the flash-point. Since the mass can safely be heated in the second type to higher temperatures and agitated at a greater speed without danger of the melted mixture splashing out of the vessel, it follows that with its use the process of amalgamation will take place more rapidly.

The dehydrated bituminous substances are introduced into the melting-tank, preferably in the melted condition, either by gravity or by means of pumps. Where this is not practical, as with high fusing-point products, such as the asphaltites or native asphalts containing a large percentage of mineral matter, they may be added cold in the solid state, but in this case it takes longer to melt up the charge.

The higher the temperature to which the materials are heated, the more rapidly will the combination take place. It is not necessary, or in fact desirable to raise the heat to the fusing-point of the ingredients melting at the highest temperature, as these will be dissolved by the constituents fusing at lower temperatures, due to their inherent *solvent* action combined with mechanical agitation. Thus, a grahamite fusing at 550 to 575° F. (K. and S. method) will readily combine with mixed-base or asphaltic residual oils brought to a temperature of 400° F., particularly if the mixture is kept well agitated. The grahamite should be introduced in the form of lumps about the size of hickory nuts, in preference to a fine powder, as the latter will sinter together if the charge is not agitated, and in addition will make it difficult to tell when the amalgamation is completed.

Great care should be taken not to overheat bituminous substances, as they are all affected either by a prolonged heating at a moderately high temperature, or upon subjecting to a comparatively high temperature for a short time. There are no general rules regarding the behavior of bituminous substances under the influence of heat. Each will act differently, and resist heat to a greater or lesser degree.

It is rarely safe to raise the temperature higher than 450-500° F. in any of the manufacturing processes involving the use of bituminous substances.¹ Overheating will manifest itself by:

(1) Increasing the specific gravity, viscosity, hardness and consistency, fusing-point, flash-point, burning-point, non-mineral matter insoluble in carbon disulphide, and carbenes.

(2) Decreasing the ductility, volatile matter, solubility in carbon disulphide and in 88° petroleum naphtha.

On fluxing native asphalts carrying a substantial percentage of mineral matter, it is important to keep the mass well agitated, otherwise the mineral matter will settle out and carbonize against the bottom of the tank, retarding the ingress of heat, and causing the bottom plates to burn out rapidly.

When the mixture is to be heated to a high temperature for other than a comparatively short time, it is inadvisable to affect the agitation by means of air, as this will increase the fusing-point in the same manner as in the production of "blown asphalts" (see p. 287). Mechanical stirrers or dry steam jets are preferable under these conditions.

Apparatus for Incorporating Fillers. As fillers are added after the bituminous mixture has been dehydrated and fluxed to the proper consistency, a steam-heated mixing apparatus of small capacity is best adapted for the purpose, constructed to mix the charge with great rapidity. Two forms of steam-jacketed agitators provided with mechanical mixers are used, viz.:

(1) A rectangular tank with a semi-cylindrical steam-jacketed bottom, commonly provided with two horizontal shafts revolving in opposite directions, each carrying two sets of short strong blades or paddles set at different angles, to work the bituminous mixture from the ends of the vessel towards the centre. The completed mixture is discharged from the bottom through a power operated slide-valve (see Fig. 117).

(2) A vertical vessel of cylindrical form provided with a steam-jacketed semi circular bottom, enclosing a vertical shaft carrying blades, geared to an auxiliary shaft, offset at one end and provided with smaller blades which revolve within the larger ones. The principle of this type is similar to that of a common "egg-beater." The inner shell is cast from a single piece of metal to avoid danger of leakage. This form of apparatus is intended only to mix in such quantities of fillers as will not destroy the fluidity of the mixture or prevent it discharging by gravity through a spout at the bottom. When fillers are used such as silica, earth-colors, or the like, mixtures can be prepared containing 60 to 65 per cent of the mineral constituents.

When it is desired to incorporate light vegetable fillers, such as cork, wood-flour, or fibres, a type of mixture may be used similar to the foregoing but mounted

¹ "Effect of Overheating Asphalts," C. J. Frankforter, *J. Ind. Eng. Chem.*, **2**, 239, 1910.

on trunnions, so that after the mixing is complete, the entire apparatus may be tipped bodily, and the contents hoed over the rim while the mass is hot. An apparatus of this type is illustrated in Fig. 116.

Emulsification. In special cases it is desirable to emulsify liquid to semi-liquid bituminous materials with water. The emulsification is brought about through the intervention of the following classes of substances: water-soluble soaps, alkalies, alkaline earths, sodium silicate,

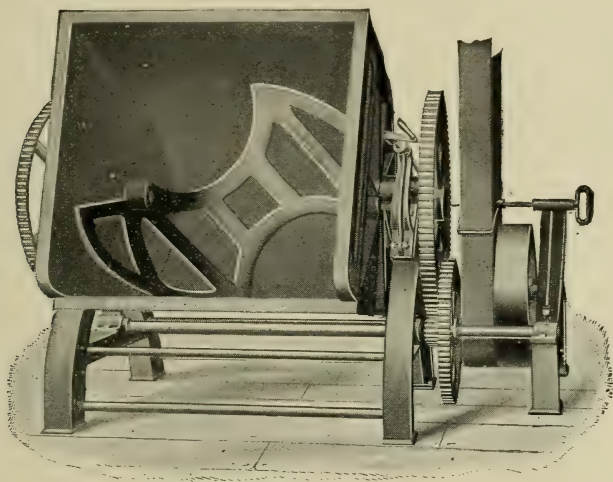

Courtesy of J. H. Day & Co.

FIG. 116.—Mixer for Incorporating Large Percentages of Fillers in Asphalt.

certain mineral oxides, plastic clay, tar distillates including pyridine bases, starchy materials, water-soluble gums, Irish moss, sulphonated oils, casein, molasses residues, etc. (see p. 354).

The emulsification is effected cold. If a liquid product is to be obtained, the bituminous material and water containing the emulsifying agent are mixed in a suitable apparatus provided with a mechanical stirring device. If the product is to be produced in paste form, the emulsification is brought about in a "masticator," or a "pug-mill" (otherwise known as a "chaser" or "chilean mill"), in which mechanical agitation is coupled with a certain amount of grinding or trituration (see p. 459).

CHAPTER XXIV

BITUMINOUS PAVING MATERIALS

BITUMINOUS materials for constructing pavements may be classified into the following groups, depending upon the specific purpose for which they are to be employed, viz.:

- (1) Bituminous dust-laying oils.
- (2) Bituminous surfacings.
- (3) Bituminous macadam.
- (4) Bituminous concrete pavements.
- (5) Sheet-asphalt pavements.
- (6) Asphalt-block pavements.
- (7) Asphalt mastic floorings.
- (8) Bituminized wood-block pavements.
- (9) Bituminous fillers for wood, brick and stone-block pavements.
- (10) Bituminous expansion joints.

These will be discussed in greater detail later.¹

The bituminous raw materials commonly employed for the above purposes embrace the following:

Crude petroleums.

Native asphalts.

Residual oils.

Residual asphalts.

Blown petroleum asphalts.

Asphaltites.

Refined water-gas tar and water-gas-tar pitch.

Refined oil-gas tar and oil-gas-tar pitch.

Refined gas-works coal tar and gas-works coal-tar pitch.

Refined coke-oven coal tar and coke-oven coal-tar pitch.

¹ "City Roads and Pavements," by W. P. Judson, N. Y., 1907; "Road Preservation and Dust Prevention," by W. P. Judson, N. Y. and London, 1908; "The Modern Asphalt Pavement," by Clifford Richardson, N. Y., 1908; "Street Pavements and Paving Materials," by Geo. W. Tillson, 1st Edition, New York, 1908; "Dust Preventatives and Binders," by Prévost Hubbard, 1st Edition, N. Y., 1910; "Asphalt Construction for Pavements and Highways," by Clifford Richardson, 1st Edition, New York, 1913; "Text Book on Highway Engineering," by A. H. Blanchard and H. B. Drowne, 1st Edition, N. Y., 1914; "The Construction of Roads and Pavements," by T. R. Agg, 1st Edition, N. Y., 1916.

These may be used either singly or in various combinations. In special cases *distillates* are used, including the heavy petroleum distillates for manufacturing dust-laying oils, and tar-distillates for impregnating wood blocks.

Bituminous materials are used without other additions in the form of bituminous dust-laying oils, fillers for wood, brick or stone pavements and in certain forms of expansion joints; and they are used in admixture with mineral aggregate for constructing bituminous surfacings, bituminous macadam, bituminous concrete pavements, sheet asphalt pavements, asphalt-block pavements, asphalt mastic flooring and certain expansion joints. They are also used in combination with wood for manufacturing bituminized wood-block pavements; with felted fabric in forming certain bituminous expansion joints; and in some cases emulsified with water for preparing dust-laying oils, and bituminous cements to be used cold.

Bituminous Dust-laying Oils. Dust-laying oils are also designated "dust preventatives" or "dust palliatives." They are usually liquid at room temperature and are adapted for use without heating, on earth, gravel or macadam roads, for temporarily resisting the formation and dispersion of dust under traffic conditions. Dust-laying oils may either be used as such, or in an emulsified state with water, and are applied to the road, preferably after removing the loose particles of dust, by any suitable form of sprinkling or spraying device, as for example an ordinary watering cart.

The function of the dust-laying oil is twofold, namely, to prevent the dispersion of dust already formed, and retard the formation of additional particles under the attrition of traffic. The saturating, *adhesive* or *binding* properties of the oil accomplish these results. At best the effect of dust-laying oils is temporary, and they must accordingly be renewed from time to time, usually twice during the first season, and once each year thereafter, assuming that the traffic conditions are not abnormally severe.

Bituminous Materials Used. The following products are employed for this purpose:

- (1) Crude petroleum of mixed-base and asphaltic nature.
- (2) Heavy petroleum distillates.
- (3) Residual oils.
- (4) Cut-back residual asphalts.
- (5) Gas-works coal tar.
- (6) Coke-oven coal tar.
- (7) Cut-back pitches.
- (8) Water-gas tar (rarely).
- (9) Oil-gas tar (rarely).

Bituminous Emulsions. It is sometimes customary to use the products with water in the form of an emulsion, obtained by mechanical or chemical means. Emulsions, on account of their greater fluidity, have the advantage of being applied more cheaply than untreated oils or tars, thus enabling them to be spread on the road without the use of a special form of apparatus. In addition, they are absorbed more rapidly by the road surface, and obviate the necessity of interfering with traffic while applied, or the annoyance of having the oil tracked about by pedestrians, as often proves the case when crude petroleum or tars are used.

Mechanical emulsions are obtained by mixing the oil (usually crude petroleum, heavy petroleum distillates or residual oil) with a suitable quantity of water, by a mechanical contrivance, just as it is about to be sprayed on the road, as for example by means of a rapidly revolving set of blades. Oils having a specific gravity approximating that of water will answer best for this purpose.

The following chemical agents have also been used for emulsifying the dust-laying oils, viz.:

(1) Soaps prepared from animal or vegetable oils and fats, which when combined with petroleum, residual oils or tars will enable them to become emulsified with water. One formula consists in emulsifying the asphalt with oleic acid and ammonia,¹ another in dissolving 20–25 lb. of common soap in the smallest quantity of hot water (40–50 gal.), and then mixing it with 100 gal. of asphalt. Rosin or rosin oil soap may also be used.²

(2) Alkalies, including ammonia, caustic or carbonated soda or potash, borax, slaked lime, etc., will give satisfactory results with tars containing phenolic bodies, due to the resulting combination acting as an emulsifier.

(3) The addition of a small percentage of certain alkaline bases including pyridine, piccolin or quinolin, will emulsify residual oil, crude petroleum or tar.³

(4) Small percentages of colloidal vegetable or animal substances, such as saponin, glue, gums, pectin substances, vegetable mucilages,⁴ sulphite liquors, waste molasses liquors⁵, starch paste, Irish moss⁶ and other glutinous substances dissolved in water. The addition of a small proportion of these substances to the oils or tars with or without the addition of soaps, will enable them to emulsify with water.

(5) A paste made up of colloidal mineral substances, such as metallic oxides, silicates, hydroxides, clay,⁷ sodium silicate ("water glass").⁸

¹ U. S. Pats. 992,313 of May 16, 1911 to L. S. van Westrum; also 998,691 of Jul. 25, 1911 to H. R. Kasson and S. S. Saxton.

² Ger. Pats. 248,084 of Dec. 5, 1909 and 248,793 of Mar. 17, 1910 to Reinhold Wallbaum; U. S. Pats. 1,258,103 of Mar. 5, 1918 and 1,259,223 of Mar. 12, 1918, both to W. M. Fraser.

³ U. S. Pat. 884,878 of Apr. 14, 1908 to J. P. Van der Ploeg.

⁴ U. S. Pat. 834,830 of Oct. 30, 1906 to Karl Mann.

⁵ "Dust Preventatives and Road Binders," Hubbard, p. 109.

⁶ U. S. Pat. 943,667 of Dec. 21, 1909 to Carleton Ellis.

⁷ F. Raschig, *J. Soc. Chem. Ind.*, **29**, 758, 1910; U. S. Pat. 1,240,253 of Sep. 18, 1917, to M. A. Popkess.

⁸ U. S. Pat. 980,513 of Jan. 3, 1911 to Robert Hacking.

- (6) Sulphonated vegetable oils such as "turkey red oil."¹
- (7) Soda sludge obtained from oil-refining works (see page 213).
- (8) By means of soluble casein solutions.²

Emulsions are usually marketed under various proprietary names, the exact composition being carefully guarded as "trade secrets," and recommended to be mixed with water, in proportions ranging from 10 to 30 per cent. It is obvious, however, that the smaller the percentage of bituminous matter present, the less the efficiency of the emulsion as a dust-laying medium, and the more often it must be renewed. The use of emulsions is attendant with the following disadvantages: They are usually applied in such weak solutions that their efficiency is impaired; the water present in the emulsion has no value from the view-point of dust-laying and necessitates the purchaser paying freight on this inactive ingredient; and further, emulsions prepared from residual oils derived from non-asphaltic and mixed-base petroleums are very apt to wash off the road upon being subjected to the action of rain or snow combined with the mechanical grinding under the wheels of traffic.

Non-emulsified Products. Non-emulsified oils and tars are usually less expensive in the long run. They are generally applied cold, but in certain cases, and particularly during cold weather, better results may be obtained by sprinkling them on the road in a heated state. The best practice necessitates using from $\frac{1}{3}$ to $\frac{1}{2}$ gal. per square yard, depending upon the nature of the road, the quantity of dust in situ, and whether or not the road has been oiled previously. On a road oiled at regular intervals, 0.1 to 0.2 gal. per square yard is sufficient after the initial application. The surface should then be sprinkled lightly with sand, using a cubic yard for every 75 to 125 sq. yd. of surface, to prevent the oil being tracked about by pedestrians and vehicles. A longer period should be given the oil to soak into gravel or macadam roads since they are denser and less porous than dirt roads. For the same reason, the oil must be applied with great care to provide a uniform distribution, and to prevent it accumulating in "pools."

Non-asphaltic petroleums and their residual oils are not looked upon with favor, owing to their deficiency in "binding" properties. Mixed-base petroleums and their residual oils give better results, but they are not regarded as equal to the asphaltic petroleums and their residual oils. In general residual oils give better results than crude petroleums, since they are more "concentrated." It is still an undecided matter whether, other

¹ U. S. Pats. 931,520 of Aug. 17, 1909 to Julius Stockhausen; 998,691 of Jul. 25, 1911 to H. R. Kasson and S. S. Saxton.

² Ger. Pat. 240,482 of May 1, 1910 to Aktiengesellschaft für Asphaltierung und Dachbedekung.

things being equal, petroleum products or "tars" are preferable, and much may be said on both sides of the question. Cut-back residual asphalts and cut-back pitches have also been largely used. They have many advantages, and among others, the fact that they set up rapidly when applied to the road, and the residue is apt to have better "binding" properties than would be the case if the corresponding crude or straight distilled products were used.

General Considerations. The following precautions should be followed to get the best results:

1. All the loose dust should be removed from the road before applying the dust-laying oil.

2. The road should be thoroughly dry and the oil applied preferably on a warm sunny day, or if this is not possible, the oil should be heated slightly before it is spread.

3. The oil should be allowed to soak into the road thoroughly before reopening it to traffic.

4. The oil should not be too viscous, otherwise it will fail to penetrate properly. Best results are obtained with oils having a specific viscosity (on the first 50 c.c.) when tested with the Engler viscosimeter (Test 8a) at 77° F. as follows:

(a) Petroleum products for use as dust palliatives (i.e., three to four applications per year at intervals), less than 10.

(b) Petroleum products for use as road oils to be applied cold (i.e., two applications per year, intended to build up a bituminous surface), 80-120.

(c) Refined tars for use as dust palliatives, 8-13.

(d) Refined tars for use as road oils to be applied cold, 25-35.

(e) Refined tars for cold patching, 40-70.

5. If the oil contains an excess of volatile matter, too much will eventually be dissipated through evaporation to enable the residue to fulfil its function efficiently. The volatile matter at 325° F. in 5 hours should not exceed 30 per cent in the case of petroleum products, nor must the residue appear "greasy." The greater its adhesive qualities and tensile strength ("cementitiousness") at 77° F. (Test 11), the more efficiently will the original oil bind together the dust particles. Tar products on distillation (Test 20) should yield the following percentages of distillate:

(a) Refined tars for use as dust palliatives: to 170° C. less than 5 per cent; to 270° C. less than 30 per cent; to 300° C. less than 40 per cent.

(b) Refined tars for use as road oils to be applied cold: to 170° C. less than 2 per cent; to 270° C. less than 25 per cent; to 300° C. less than 35 per cent.

(c) Refined tars for cold patching: to 170° C. more than 2 per cent; to 270° C. 15-25 per cent; to 300° C. less than 30 per cent.

6. Petroleum products should show not exceeding 1 per cent non-mineral matter insoluble in carbon disulphide; refined tars for use as dust palliatives or as road oils to be applied cold, not more than 10 per cent free carbon (Test 31); and refined tars for cold patching, not exceeding 20 per cent free carbon.

7. The dust-laying oil should not show a tendency to emulsify when subjected continuously to the action of moisture or upon being ground up in the form of a paste with the dust or mud generated by traffic. Certain oils and especially those prepared from non-asphaltic or mixed-base petroleum are apt to become miscible

with water under these conditions, and wash away from the surface of the road. The product may be tested for this defect by grinding the residue remaining after the volatility test in a mortar with an equal weight of colloidal clay made into a paste with water, and observing whether any emulsification takes place.

Bituminous Surfacing. A bituminous surfacing consists of a layer of appreciable thickness constructed on top of a newly prepared or an old roadway, by the application of one or more coats of bituminous material interposed with gravel, sand or stone chips. When used for surfacing gravel, stone or concrete roads, it is usually termed a "carpet" or a "carpeting coat," and when used for surfacing roads constructed of a bituminous wearing course including bituminous macadam and bituminous concrete pavements, it is referred to as a "seal-coat." In the latter case the function of the bituminous surfacing is to fill the voids of the bituminous foundation and produce a smooth and uniform wearing surface.

The objects of the bituminous surfacing are to prevent the formation of dust by attrition, to provide a somewhat elastic cushion or "carpet" to take the wear and preserve the denser material upon which it is laid, to make the road less noisy, and to increase the comfort of those who travel over the pavement. Bituminous surfacings will only give good results on roads providing a *firm* and well compacted foundation. New roads should accordingly be opened up to traffic for some time until all the small particles and loose dust have been worn off, and any local settling may have taken place.

Bituminous Binder. Bituminous binders for use in constructing bituminous surfacings may be divided into two groups, viz.: (a) suitable for application to gravel, stone or concrete pavements, and for the *maintenance* of bituminous macadam and bituminous concrete pavements; (b) suitable for preparing the *original* bituminous surfacing in constructing bituminous macadam and bituminous concrete pavements (usually termed "seal coats"). The first group only will be considered under this heading. The bituminous binders included in the second group will be described under the headings of bituminous macadam and bituminous concrete pavements, as they consist of the same character of bituminous materials as used in the construction of the wearing course of these respective pavements

The bituminous materials used for preparing the bituminous surfacings of group (a) are usually viscous, semi-liquid to semi-solid in consistency and suitable for application in a heated condition by a mechanical distributor capable of forcing it on the road under more or less pressure. They are usually applied at a temperature of 225-275° F., and should possess or develop shortly after their application, suffi-

cient adhesiveness to bind together the covering of sand, gravel or stone chips. The bituminous material is frequently composed of a "cut-back" residual asphalt or pitch, prepared from a base of great adhesiveness, combined with a suitable proportion of volatile constituents intended to evaporate within a short time after the bituminous surfacing is applied. The following may be used for preparing the surfacing:

- (1) Fluxed native asphalts. (It is possible to use these, but at present none are so employed.)
- (2) Blown petroleum asphalt of the proper consistency.
- (3) Residual asphalts, including "cut-back" products.
- (4) Residual or refined tars, including water-gas tar, oil-gas tar, gas-works coal-tar and coke-over tar.
- (5) Cut-back pitches, including cut-back water-gas-tar pitch, oil-gas-tar pitch, gas-works coal-tar pitch, and coke-oven coal-tar pitch.

The bituminous binder should comply with the following characteristics when tested in its pure state:

	Tar Products.	Asphaltic Products.
Viscosity by float test at 90° F. (Test 8d).....	60-150	60-150
Ductility at 77° F. (Tests 10a and 10b).....	> 50	> 50
Fusing-point (K. and S. method, Test 15a).....	<105° F.	<105° F.
Volatile at 325° F. in five hours (Test 16a).....	<15%
Viscosity residue by float test at 122° F. (Test 8d).....	>110
Distillation test (Test 20):		
To 170° C. (by weight).....	<1%
To 270° C. (by weight).....	<15%
To 300° C. (by weight).....	<25%
Soluble in carbon disulphide (Test 21a).....	> 85%	> 98%
Non-mineral matter insoluble (Test 21b).....	<15%	< ½%
Mineral matter (Test 21c).....	< ½%	<1%
Soluble in 88° naphtha (Test 23).....	> 90%

Mineral Aggregate. The top dressing should consist of coarse sand, fine gravel or screened grit (stone chips) whose particles vary from $\frac{1}{8}$ to $\frac{1}{2}$ in. in their longest dimension. The grit may be graded from $\frac{3}{4}$ in. down, but should contain no "dust." One cubic yard of sand weighing approximately 2700 lb. should cover 50 to 100 sq. yd. of road surface in the hot process and 100 to 150 sq.yd. in the cold treatment (i.e., dust-laying oils). The harder the character of the top dressing, the better. Cubical particles are less liable to displacement under traffic than rounded particles.

Preparing and Applying the Surfacing. The following steps should be carefully observed:

(1) The original cross-section of the road should be restored, proper drainage provided, and any ruts or depressions filled with crushed stone or gravel, levelled by rolling, and thoroughly bonded.

(2) Any loose dust, chips or other particles should be removed by

sweeping with hand or power brooms, or in extreme cases with shovels or power scrapers.

(3) The weather should preferably be clear and warm.

(4) The road surface should be clean and dry. This is essential to secure the proper bonding of the surfacing to the wearing course. In certain cases a light preliminary cold application of liquid bituminous material or "primer" will promote the adhesion. With macadam, best results are obtained by removing the fine particles between the larger stones to a depth of $\frac{1}{4}$ to $\frac{1}{2}$ in. to enable the surfacing to "key" with it.

(5) The tar or asphalt should be heated to 225 to 275° F., and applied with a suitable pressure distributor, which will impinge it against the surface of the road in jets propelled at great velocity, and at the same time remove any dust which may have been overlooked. If the pressure is too great, the bituminous material is likely to be atomized into fine particles whose impact will be lessened.

(6) The quantity of bituminous material required for the first treatment will vary from $\frac{1}{3}$ to $\frac{3}{4}$ gal. per square yard of surface, averaging $\frac{1}{2}$ gal., depending upon the character and smoothness of the surface. It should be applied uniformly and smoothly.

(7) Some recommend that the bituminous surfacing should be allowed to remain on the road at least twelve hours, to enable it to soak in as much as possible before the mineral surfacing is applied. Others recommend placing the top dressing immediately.

(8) After the top dressing is applied, it should be thoroughly rolled with a steam roller to incorporate the mineral matter with the bituminous coating.

(9) The finished bituminous surfacing should vary in thickness from $\frac{1}{4}$ to $\frac{3}{8}$ in.

General Considerations. The success of this method will depend upon:

(1) The nature of the foundation to which the bituminous surfacing is applied. Macadam, concrete and well-constructed bituminous-macadam pavements give the best results. Bituminous surfacings do not stand up as well on gravel roads, as they are apt to peel off after a time, unless a primer is used.

(2) The thoroughness with which the bituminous surfacing adheres to the foundation.

(3) The nature of the binder used. Bituminous substances whose residues possess great ductility, tensile strength and "adhesive" qualities will give the best results. They should not be too susceptible to temperature changes or contain too large a percentage of volatile constituents. Petroleum products made from asphaltic petroleum will give better results than those obtained from a mixed-base petroleum.

(4) The nature of the top dressing. Cubical particles of grit or stone-chippings free from dust, produced from hard rocks will give better results than mineral matter derived from soft rocks, which are liable to powder under heavy traffic.

Rounded mineral particles are not as satisfactory as angular ones, as they are more apt to become displaced.

Numerous mechanical appliances have been devised for spreading the bituminous material, the modern and most efficient ones being operated by a motor which serves not only to propel the vehicle, but also to apply the bituminous material under pressure. Heat is supplied by burning wood or coal in a small grate underneath the tank. Steam-jacketed tanks are also used.

Bituminous Macadam. This form of pavement is also known as "asphalt macadam," "bituminous gravel," "bituminous broken stone," "asphalt broken stone," etc. Its wearing course is composed of mineral particles bound together and having the interstices filled with a bituminous binder introduced by the "penetration method," which consists in first rolling the mineral particles in place and applying the melted bituminous binder afterwards.

Foundation Course. The firmer the foundation, the more durable will the pavement be. Either a Telford macadam, or well drained gravel foundation is recommended. Sand or gravel roads are frequently too soft to give good results. If the foundation is worn or rutted or filled with holes, it should be levelled and rolled before the surface course is applied.

Mineral Aggregate. Upon the foundation course is spread an intermediate course composed of $\frac{1}{2}$ - to 3-in. broken stone, which after rolling is compacted in a layer 2 in. deep on old macadam roadways or 5 in. deep on new roadways designed to carry heavy traffic. This is bonded together by filling the interstices with smaller-sized stone, sand, screenings or stone-dust, and rolled until thoroughly compacted. Upon the intermediate course is spread the surface course which is subsequently treated with the bituminous binder. When the surface course is to be applied in an uncompacted layer 4 in. thick, corresponding to 3 in. after rolling, the stone particles may vary from 2 to $3\frac{1}{2}$ in. When the surface course is to be applied in an uncompacted layer 3 in. thick corresponding to 2 in. after rolling, the stone particles may range from 1 to $2\frac{1}{4}$ in. All depressions must be filled. Crusher stone consisting of cubical fragments gives the best results. Crushed gravel may be used for the mineral aggregate in localities where broken stone is not obtainable.

Bituminous Binder. The binder used in penetration method may consist of the following groups of products:

(1) Native asphalts used alone when of a suitable consistency, or else fluxed to grade with softer native asphalts, residual oil, soft residual asphalts or soft blown petroleum asphalt.

(2) Asphaltites fluxed to the required consistency and fusing-point with residual oil, soft native asphalt, soft residual asphalt, or soft blown petroleum asphalt.

(3) Residual asphalts used alone when of the required consistency, or else fluxed

to grade with residual oil, soft native asphalt, soft residual asphalt or soft blown petroleum asphalt.

(4) Blown petroleum asphalts used alone when of the proper consistency, or else fluxed to grade with soft native asphalts, residual oils or soft residual asphalts.

(5) Water-gas-tar pitch, oil-gas-tar pitch, gas-works coal-tar pitch or coke-oven-tar pitch, used either singly or in various combinations, and without other additions when of the required consistency; or else if too hard, cut back to grade with the corresponding liquid tar evaporated to remove the highly volatile oils, or a small proportion of high boiling-point distillate derived therefrom.

The bituminous binder should comply with the following tests:

	Tar Products.	Asphaltic Products.
Viscosity by float test at 122° F. (Test 8d).....	90-120
Penetration at 77° F. (Test 9b).....	80-160
Penetration at 32° F. (Test 9b).....	> 8
Ductility at 77° F. (Test 10a or 10b).....	> 25	> 25
Fusing-point (B. and R. method, Test 15b).....	95-135° F.
Fusing-point (Cube method, Test 15c).....	85-115° F.
Volatile at 325° F. in five hours (Test 16a).....	<5%
Penetration residue at 77° F. (Test 9b).....	> ½ original penetration
Flash-point (Test 17a).....	> 325° F.	> 350° F.
Distillation test (Test 20):		
To 170° C. (by weight).....	<1%
To 270° C. (by weight).....	<10%
To 300° C. (by weight).....	<20%
Fusing-point residue (Test 15c).....	<150° F.
Soluble in carbon disulphide (Test 21a).....	> 85%	> 97%
Non-mineral matter insoluble (Test 21b).....	<15%	<2%
Mineral matter (Test 21c).....	<½%	<1%
Carbenes (Test 22).....	<1½%
Soluble in 88° naphtha (Test 23).....	65-85%

Preparing and Applying the Surface Course. The surface course is applied to the intermediate course as described, in a layer 2 to 3 in. thick when compacted, and sprinkled with bituminous binder under a pressure of 30 to 60 lb. per square inch from a mechanical contrivance similar to that used in the surfacing method. Very soft rock should be sprinkled *before* rolling. The bituminous material may be heated between 250 and 300° F. in the case of tar products, and from 300 to 350° F. with asphaltic mixtures, and applied at the rate of $\frac{7}{8}$ gal. per square yard for each inch thickness of the compacted wearing surface. The road is then immediately covered with a dusting of $\frac{3}{8}$ in. screenings preferably heated, and well rolled with a 15 to 18-ton roller, after which a seal-coat of bituminous material (p. 367) is applied, at the rate of $\frac{1}{4}$ to $\frac{1}{2}$ gal. per square yard, covered with chips and again rolled.

General Considerations. The following precautions should be observed:

- (1) The foundation course should be unyielding and substantial.
- (2) Tough and durable stone of cubical form and free from dust should be used as mineral aggregate in the wearing course.
- (3) The bituminous binder should be distributed uniformly *throughout* the entire wearing course. This may be assured by applying the binder in two or more layers on relatively thin courses of aggregate.
- (4) The bituminous binder should be applied in just the right quantity, neither too much nor too little. If too much is applied, the binder will "bleed" from the road in warm weather, and if too little, the bond will be broken in service.

Bituminous Concrete Pavements. This method differs from the foregoing in the fact that the mineral aggregate is heated and mixed with the bituminous binder *before* it is applied to the road. This overcomes the main difficulty of the penetration method and insures a *uniform* distribution of the bituminous material. The name "bituminous concrete" is given on account of its analogy to a Portland-cement concrete, in which the mineral aggregate has its voids filled with Portland cement in one case and with a bituminous cement in the other. It has also been termed "stone-filled sheet asphalt pavement," and may be regarded as a mortar of the composition used in the construction of the surface course of sheet asphalt pavements, having $\frac{1}{4}$ to $1\frac{1}{2}$ in. stone uniformly distributed and embedded therein. This type of construction is rapidly superseding bituminous macadam, in spite of the fact that the latter is considerably less expensive. The modern tendency is to produce a very dense wearing course, characterized by a smaller proportion of voids than in bituminous macadam.

Foundation or Base Course. The most satisfactory foundation consists of a Portland-cement concrete, or a well-compacted macadam; less satisfactory results being obtained from gravel or broken stone foundations. The same precautions should be followed in levelling and grading the macadam, broken stone or gravel foundation as described under the respective headings "Bituminous Surfacing" and "Bituminous Macadam." In the case of a Portland-cement concrete foundation, the directions should be observed as described on p. 367. Macadam foundations should never be less than 6 in. thick, or Portland-cement concrete less than 4 in.

Mineral Aggregate. This should be selected and proportioned with the greatest care, since the success or failure of the pavement will largely depend upon the character and blending of the aggregate. It may consist of a screened rock of the sizes used for the penetration method, or an attempt may be made to reduce the percentage of voids by using a graded aggregate consisting of crusher-run stone, or a mixture of crusher-run

stone with sand, with or without the addition of dust or filler. When such aggregate is not available, sand passing a $\frac{1}{4}$ -in. screen and gravel ranging in size from $\frac{1}{4}$ to $1\frac{1}{2}$ in. may be used in such proportions that the mixture will have the smallest percentage of voids (determined as described on p. 369). The stone should be hard and tough with cubical fragments. Crushed quartz or trap-rock are recommended, but hard, finely crystalline limestone will also give good results. Granite is less satisfactory, and gravel should only be used where the other types of stone are not procurable. Slag, shells or cinders are not recommended. In the western portion of the United States, where hard rocks are not available for aggregate, bituminous concrete pavements have not given very satisfactory results.

The sand should be clean, graded and composed of *medium* sharp grains, neither too angular nor rounded. Sands are classified as beach, river, bank, disintegrated sandstone and artificial sands, but each group varies in its characteristics, so that it is impossible to reach any conclusions regarding their relative efficiencies without subjecting them to a granulometric examination.

Sometimes the sands carry sufficient fine particles to satisfactorily fill the voids. When this is not the case, additional dust or filler should be added, consisting of ground limestone, trap-rock, volcanic rock, silica, shale, powdered clay or marl and either Portland or natural cement. At the present time limestone dust is most commonly used for this purpose and sometimes Portland cement. Fillers should be of such a texture that at least 75 per cent will pass a 200-mesh sieve, and not less than 66 per cent remain suspended in water at 68° F. for fifteen seconds (see Elutriation Test, p. 541.) The amount of filler added will depend upon:

- (1) Whether the bituminous cement contains mineral matter.
- (2) Whether there are any fine particles of "dust" present in the sand.

The grading of the stone, sand and filler should be controlled very carefully to obtain an aggregate of the greatest possible density, or in other words, the smallest percentage of voids. Thus, the voids of the broken stone should be completely filled with sand, the voids of the sand in turn filled with dust, and the voids of the dust in turn filled with bituminous cement. The "voids" may be determined by finding the specific gravity of the stone, sand and dust respectively, and then calculating the proportion of voids in a given volume. This may be arrived at by finding the weight of a given volume moderately compacted. The voids will then be found by dividing the weight by the gravity, and subtracting the result from the volume. The voids are figured in percentage.

Another method consists in filling a receptacle of exactly 1 cu. ft. capacity with the aggregate moderately compacted. A measured volume of water is poured into the receptacle until it is ready to overflow, the exact volume of water used being equal to the volume of voids in the aggregate or filler under test. The proportion of bituminous binder to be added should be calculated from the volume of voids in the completed mineral aggregate. In most cases the proportion of bituminous cement is expressed in percentage by *weight* of the final mixture containing the aggregate. This, however, is liable to give misleading results, as correctly pointed out by Hubbard,¹ who suggests that the specific gravity of both the aggregate and the

¹ "The Bitumen Content of Coarse Bituminous Aggregates," *Proc. Int. Assoc. Testing Materials*, 6th Congress, 11, XXV-2. 1912.

pure extracted bituminous cement should be reported. To show the fallacy of the method of expressing the proportion of bituminous cement by weight, Hubbard assumed the case of two aggregates both having the same percentage (6 per cent) by *weight* of bituminous cement free from mineral matter, the aggregate in one case having a specific gravity 2.50 and the pure bituminous cement 1.17, and in the other case the aggregate 3.50 and the pure bituminous cement 0.96. The percentage of bituminous cement by *volume* will, however, vary greatly as shown by the following figures:

	Per Cent by Weight.	Specific Gravity.	Proportion by Volume.	Per Cent by Volume.
<i>First mixture:</i>				
Aggregate.....	94	2.50	37.6	88
Pure bituminous cement.....	6	1.17	5.1	12
Total.....	100	100
<i>Second mixture:</i>				
Aggregate.....	94	3.50	26.9	81
Pure bituminous cement.....	6	0.96	6.3	19
Total.....	100	100

It will be observed that although both mixtures contain the *same* percentage of bituminous cement by *weight*, they show a variation of 7 per cent in their percentages expressed by *volume*, which is more than sufficient to result in the success or failure of the paving mixture. The following figures show the relation of the percentages by volume and weight of a dense mixture used for heavy traffic (Riverside Drive, New York City).¹

	Per Cent by Weight.	Per Cent by Volume.
Pure asphalt (Bermudez).....	9.82	22.48
Portland cement.....	10.25	8.03
Sand.....	26.64	24.39
Stone.....	53.29	45.10
Total.....	100.00	100.00

Specific gravity at 77° F. when ultimately compressed: 2.434

In arriving at the proper proportions, neither the dust nor the bituminous cement should be present in excess, as these tend to make the mixture too smooth to form a proper bond with the foundation, also too slippery under traffic.

Bituminous concrete pavements may be sub-divided into two classes, viz.:

(1) Containing less than 10 per cent of stone passing a $\frac{1}{2}$ -in. screen and having greater than 21 per cent of voids, based on the so-called "Topeka specification"; and

(2) Containing greater than 10 per cent of stone passing a $\frac{1}{2}$ -in. screen and having less than 21 per cent of voids in the mineral aggregate, based on the "bitulithic specification."² Typical mixtures are included in the following table:

¹ Private communication from Clifford Richardson.

² Embodied in U. S. Pats. 675,430 of Jun. 4, 1901; 727,505 and 727,512 of May 5, 1903; 738,965 of Sep. 15, 1903; all issued to F. J. Warren.

	Topeka Mix- ture.	Used in N. Y.	Used in Spokane.	Richard- son's Mix- ture.	Bitu- lithic Mix- ture.	Warren- ite.	Richard- son's Mix- ture.	Wash- ington, D. C. 1911-14
Passing 200-mesh sieve.	5-11	11.9	4-8	8.7	4-7	5-10	2-10
Passing 100-mesh sieve.	5-10	8.6	3-10
Passing 80-mesh sieve..	14.5	10-20	8.7	15-20	½-2
Passing 40-mesh sieve..	18-30	18.6	15-30	23.2	3-6
Passing 10-mesh sieve..	25-55	18.9	25-40	10.6	24-32	5-10	25-35	15-30
Passing 8-mesh sieve.	1-3	½-3
Passing ¼ in. screen....	8-22	19.1	15-40	22.0	8-12	5-10	3-12	3-20
Passing ½ in. screen....	<10	8.1	<10	10.0	12-20	10-20	10-30	15-25
Passing 1 in. screen....	26-35	40-60	20-35	15-30
Retained on 1 in. screen.	36-50		0-10	0-20
Bituminous cement....	7-11%	8.9%	7-10%	8.2%	7-9½%	5-10%	7-9%	7-8%
Voids in aggregate....	>21%	>21%	>21%	<21%	<21%	15-20%	20-21%

Percentages expressed by weight.

Bituminous Cement or Binder. The bituminous cement is semi-solid in consistency, and may be composed of the groups of bituminous materials enumerated under "Bituminous Macadam" (p. 360). It should comply with the following characteristics:

	Tar Products.	Asphaltic Products.
Viscosity by float test at 122° F. (Test 8d)....	120-180
Penetration at 115° F. (Test 9b).....	<350
Penetration at 77° F. (Test 9b).....	60-120
Penetration at 32° F. (Test 9b).....	>25
Ductility at 77° F. (Dow Method, Test 10a) ..	>10	>10
Tensile strength at 77° F. (Test 11).....	>0.5	>0.5
Fusing-point (K. and S. method, Test 15a)....	80-110° F.
Fusing-point (B. and R. method, Test 15b)....	100-135° F.
Fusing-point (Cube method, Test 15c).....	115-150° F.
Volatile at 325° F. in five hours (Test 16a)....	<3%
Penetration residue at 77° F. (Test 9b).....	> ½ original penetration
Volatile at 500° F. in four hours (Test 16a)....	<7%
Flash-point (Test 17a).....	>350° F.	>400° F.
Distillation test (Test 20):		
To 170° C. (by weight).....	<1%
To 270° C. (by weight).....	<10%
To 300° C. (by weight).....	<20%
Fusing-point residue (Test 15c).....	<175° F.
Soluble in carbon disulphide (Test 21a).....	>80%	{ >65% for Trinidad binder
Non-mineral matter insoluble (Test 21b).....	15-25%	{ >95% for other binders
Mineral matter (Test 21c).....	<½%	<2½%
Carbenes (Test 22).....	{ <30% for Trinidad binder
Non-mineral matter soluble in 88° naphtha	{ <3½% for other binders
(Test 23).....	<2%
		>75%

The important features of the bituminous cement are as follows:

- (1) Its penetration (Test 9b) should be controlled within definitely prescribed limits.
- (2) It should be slightly susceptible to temperature changes (Test 9d).
- (3) It should possess great ductility (Test 10a).
- (4) It should have great tensile strength (Test 11).
- (5) It should show but a small percentage of volatile matter (Test 16).
- (6) Asphaltic cements should contain only small percentages of non-mineral matter insoluble in carbon disulphide (Test 21a), also carbenes (Test 22).

Good results have been obtained by utilizing the surfacing material ripped from old sheet asphalt pavements (p. 368), mixed with a suitable proportion of coarse stone, and enriched with additional bituminous cement, softer than that originally employed in the sheet asphalt surfacing mixture,¹ since the bituminous cement of bituminous concrete pavements should be considerably softer than that used in the wearing course of sheet asphalt pavements. The following figures show the relative penetrations at 77° F. (needle pentrometer Test 9b):

Wearing surface of sheet asphalt pavements.....	Average of 35
Bituminous cement in bituminous concrete pavements.....	Average of 85
Bituminous binder in bituminous macadam pavements.....	Average of 120

The greater the percentage of filler in the aggregate, the softer the bituminous cement may be, and the larger its proportion incorporated in the mixture (see Sheet Asphalt Pavements, p. 369).

Preparing and Applying the Mixture. The best practice provides that the stone and sand (or filler) shall be heated separately in a rotary heater, as the particles of sand due to their smaller size will heat more rapidly. With tar products, the aggregate should be heated not exceeding 300° F., and with asphaltic products not exceeding 400° F. The coarse and fine portions of the heated aggregate respectively are stored in separate bins so that may be weighed individually.² The bituminous cement should also be melted separately to a temperature corresponding to that of the aggregate, whereupon suitable proportions of the stone, sand, filler and bituminous cement are mixed together in a twin-pug or other suitable mixer (see p. 372) for at least one minute at a temperature of 275 to 375° F. When thoroughly mixed, the bituminous concrete, now at a temperature of 250 to 325° F., is hauled to the road in covered wagons, and spread on the street at 230 to 280° F. with heated rakes or shovels forming a uniform layer of the desired thickness. The mixture is thereupon compressed by an 8 to 10-ton roller into a uniform layer either 2 or 3 in. thick, depending upon the severity of the traffic encountered. Another alternative, representing what is now considered to be very good practice, consists in first applying 2 in. of close binder (see Sheet Asphalt Pavement, p. 368), which in turn is surfaced with 1 to 1½ in. of bituminous

¹ U. S. Pat. 938,698 of Nov. 2, 1909 to J. A. W. Pine.

² Clifford Richardson, *Eng. News*, 80, 109, 1908.

concrete (asphaltic). The road may be finished in this manner, or it may be finished by applying a seal coat. If without the seal coat, a light dusting of powdered limestone or Portland cement should be spread on the surface and rolled in.

Finishing Coarse Aggregates with a Seal Coat. To obtain the best results with coarse aggregates a seal coat should be applied under pressure at 200 to 350° F., and manipulated in substantially the same manner as described for bituminous surfacings ("carpet coats"), using $\frac{1}{4}$ to 1 gal. per square yard, covered with pea gravel or stone chips (the particles measuring $\frac{1}{4}$ to $\frac{1}{2}$ in. in diameter) at the rate of 1 cu.yd. per 50 to 100 sq.yd., and firmly rolled in place. In some cases the seal coat consists of the same bituminous cement used for preparing the bituminous concrete, and in other instances a harder bituminous cement, testing as follows:

(Test 9b)	Penetration at 115° F.....	Less than 100
	Penetration at 77° F.....	60-30
	Penetration at 32° F.....	Greater than 10
(Test 15a)	Fusing-point (K. and S. method).....	110-115° F.
(Test 15b)	Fusing-point (B. and R. method).....	130-140° F.
(Test 15c)	Fusing-point (Cube method).....	175-200° F.
(Test 16a)	Volatile at 325° F. in five hours.....	Less than 1%
	Penetration residue at 77° F.....	Greater than 25
	Penetration residue at 32° F.....	Greater than 10
	Volatile at 500° F. in four hours.....	Less than 3%
(Test 17a)	Flash-point.....	Greater than 400° F.
(Test 10a)	Ductility at 77° F. (Dow method).....	Greater than 2

The remaining tests in either case should be the same as for the cement in the bituminous concrete layer.

General Considerations. When properly constructed, bituminous concrete is as durable as any form of bituminous pavement, but its cost is high. It has the advantage over the sheet asphalt pavement in being less slippery in wet or freezing weather, due to the grit embedded in the surface. Failures are due to an unstable foundation, the improper proportioning of the aggregate, or the use of a bituminous cement of faulty characteristics.

Sheet-asphalt Pavements. A sheet-asphalt pavement is one prepared by the mixing method, composed of an intermediate or binder course of bituminous concrete, and a wearing course composed of asphaltic cement and sand of *predetermined grading*, with or without the addition of mineral filler (dust).

Foundation or Base Course. The foundation or base course may consist of a brick or a block pavement, and sometimes old macadam. The most satisfactory foundation is composed of Portland-cement concrete 4 to 9 in. thick, depending upon the severity of traffic. The concrete should consist of Portland cement, gravel or broken stone, and sand in proportions ranging from 1 : 2 : 5 to 1 : 3 : 6, depending upon the nature of the aggregate available. The surface of the hydraulic concrete should

be levelled carefully and finished smooth, since any irregularities will be transmitted to the wearing course, giving it an uneven surface.

Intermediate or Binder Course. This may be classified in two types known as "open binder" and "close binder" respectively. The former corresponds to the ungraded coarse-aggregate bituminous concrete, and the latter to a graded bituminous concrete. Asphaltic cement is used in both cases. The binder course is constructed 1 to 2 in. thick after compression, depending upon the severity of the traffic.

The open binder is prepared from broken stone, the fragments of which are largely of one size, ranging from $\frac{1}{2}$ to 1 in. in diameter. No attempt is made to secure a graded aggregate or a dense mixture free from voids. Trap rock or hard and tough limestone (non-crystalline) is best suited for the purpose, although in certain cases granite may be used where the other rocks are not procurable.

The average weight of crushed stone suitable for the binder course approximates 100 lb. per cubic foot, requiring $3\frac{1}{2}$ to $5\frac{1}{2}$ per cent by weight of asphaltic cement. It is prepared and laid in the same manner as bituminous concrete pavements. The same asphaltic cement may be used in the open type of intermediate course as in the surface course (see p. 370).

A close binder is better adapted to withstand heavy traffic than an open binder, and is now largely being used in place of the latter. It is prepared in the same manner as asphaltic concrete (see p. 262), and is laid in a course measuring 1 to 2 in. thick when compressed. Old asphalt pavements as they are removed from the street preparatory to resurfacing are often converted into close binder, as previously described, by heating with steam and mixing in broken stone and asphaltic cement to increase the percentage and soften the consistency of the cement present in the old mixture.

Surface or Wearing Course. This is composed of a graded sand, filler and asphaltic cement. The durability of the pavement will depend:

- (1) Upon the care with which the mineral aggregate is graded.
- (2) Upon the percentage and characteristics of the asphaltic cement.

The following points are of importance in arriving at the basis of a proper surface mixture:¹

- (1) Aggregate passing a 200-mesh sieve.
- (2) Aggregate passing 80- but retained on a 200-mesh sieve.
- (3) Aggregate passing 40- but retained on an 80-mesh sieve.
- (4) Aggregate passing 10- but retained on a 40-mesh sieve.
- (5) Aggregate retained by a 10-mesh sieve.
- (6) Pure asphalt present (free from mineral constituents)

¹ For an explanation of the various sieves used, see p. 540.

The following mixtures have given good results:

	SPECIFICATIONS, BOROUGH OF MANHATTAN.		RICHARDSON'S SPECIFICATIONS.		FIFTH AVE., N. Y. CITY.
	Medium Traffic.	Heavy Traffic.	Medium Traffic.	Heavy Traffic.	Heavy Traffic.
	Per Cent.	Per Cent.	Per Cent.	Per Cent.	Per Cent.
Passing 200-mesh	12-18	13-20	10.0	13.0	17.4
Passing 80; retained 200...	10-30	13-30	18.0	26.0	33.4
Passing 40; retained 80...	20-55	20-55	38.0	34.5	32.1
Passing 10; retained 40...	10-35	10-30	24.0	16.0	21.5
Retained 10-mesh	0	0	0.0	0.0	3.7
Asphaltic cement (pure)...	9.5-12.5	10.0-12.5	10.0	10.5	10.6

A properly balanced mineral aggregate should contain sufficiently fine material "passing 200-mesh," to make the compressed pavement dense, tough, slightly susceptible to temperature changes, unaffected by water, and not liable to displacement in service. Too much material "passing 200-mesh" will cause the pavement to "ball up" and prevent it from spreading easily while in a heated condition; it is also apt to make the finished pavement "mushy" and liable to indentations; and it will consume an excess of asphaltic cement, at a correspondingly increased expense. The fine material "passing 200-mesh" is usually added in the form of "filler," or "dust" (see p. 363), the quantity of which will depend largely upon whether or not the asphaltic cement itself contains mineral matter. Thus in the case of the Trinidad asphaltic cement, naturally containing a percentage of clay and silica, 20 per cent less filler must be added than with a Bermudez asphaltic cement almost free from associated mineral constituents. The quantity of filler to be added to the sand should be regulated so that the surface mixture will contain not less than 10 per cent "passing 200-mesh" when the pavement is to be subjected to moderate traffic conditions, nor more than 18 per cent, when intended to withstand heavy traffic.

The aggregate must contain sufficient particles "passing 80—but retained on a 200-mesh sieve" to overcome the tendency of the filler to "ball up" the surface mixture while it is being spread on the pavement, enabling the mixture to spread out easily and form a dense surface under compression, capable of resisting the action of water.

The particles "passing 10—but retained on a 40-mesh sieve" from the "backbone" of the pavement, as it were, preventing the mixture from becoming displaced in service, and forming a less slippery wearing surface.

Asphaltic cement should be present in just sufficient quantity to completely fill the voids in the aggregate after compression. Too little will form a pavement lacking strength, and liable to crack upon being subjected to changes in temperature. Too large a proportion will make the surface mixture "mushy" so that the particles of sand are apt to become displaced under traffic. Modern practice calls for 9 to 17 per cent of asphaltic cement, depending upon the character of the aggregate and the conditions under which the pavement will be subjected. Richardson has patented a mixture containing at least 10 per cent mineral particles passing 200-, 100- and 80-mesh sieves respectively, and not less than 10½ per cent pure asphalt.¹

¹ U. S. Pat. 607,884 of Jul. 26, 1898 to Clifford Richardson.

It is unusual to find one sand fulfilling all of the foregoing requirements. Generally two or more sands must be blended together, and a suitable proportion of filler added, to produce an aggregate of the optimum characteristics. Richardson makes a special virtue of the fact that refined Trinidad asphalt contains naturally about 27 per cent filler composed largely of "colloidal" particles.¹ In some cases an aqueous paste of "colloidal" clay is purposely added to pure asphalts to simulate the Trinidad mixture.² Oklahoma rock asphalts carrying about 12 per cent of pure asphalt are well suited for constructing sheet asphalt pavements, as they are resistant towards atmospheric conditions and do not become brittle at low temperatures, thus resembling the Seyssel and Neuchatel asphalts.³ It is estimated that $2\frac{1}{4}$ - $13\frac{1}{2}$ million tons are available.⁴

The following figures show the relation between the percentages by weight and volume in a standard surface mixture.⁵

	By Weight. Per Cent.	By Volume. Per Cent.
Pure asphalt cement.....	10.5	23.1
Passing 200-mesh sieve.....	13.0	11.4
Passing 100-mesh sieve.....	13.0	11.1
Passing 80-mesh sieve.....	13.0	11.1
Passing 50-mesh sieve.....	23.5	20.0
Passing 40-mesh sieve.....	11.0	9.4
Passing 30-mesh sieve.....	8.0	6.8
Passing 20-mesh sieve.....	5.0	4.3
Passing 10-mesh sieve.....	3.0	2.8
	100.0	100.0

Asphaltic Cement. The asphaltic cement should be somewhat harder than that used in bituminous concrete pavements, complying with the following characteristics:

(Test 8b)	Float test at 150° F. ⁶	Less than 10 minutes
(Test 9b)	Penetration at 115° F. ⁶	Less than 300
	Penetration at 77° F. ⁶	25-45
	Penetration at 32° F. ⁶	Greater than 10
(Test 10a)	Ductility at 77° F. (Dow method).....	Greater than 20
(Test 15a)	Fusing-point (K. and S. method) ⁶	90-120° F.
(Test 15b)	Fusing-point (B. and R. method) ⁶	105-140° F.

¹ "The Theory of the Perfect Sheet Asphalt Surface," Clifford Richardson, *J. Ind. Eng. Chem.*, **7**, 463, 1915; "Importance of the Relation of Solid Surfaces and Liquid Films in Some Types of Engineering Construction," Clifford Richardson, *Proc. Western Soc. Engineers*, Chicago, Nov. 20, 1916.

² U. S. Pats. 1,198,769 and 1,198,955 of Sep. 19, 1916 to Clifford Richardson.

³ "Weathering of Rock Asphalts of U. S. in Pavements," S. F. Peckham, *Trans. Am. Inst. Chem. Eng.*, **5**, 245, 1913.

⁴ "Oklahoma Rock Asphalts for Paving," L. C. Snider, *J. Soc. Chem. Ind.*, **34**, 30, 1915.

⁵ Private communication from Clifford Richardson.

⁶ The float, penetration and fusing-point tests apply to pure asphaltic cement free from mineral constituents. In the case of Trinidad asphaltic cement these tests should be performed on the portion soluble in carbon disulphide, since the presence of mineral matter increases both the hardness and the fusing-point of bituminous mixtures (see p. 346). This is important and should not be overlooked.

(Test 16a)	Volatile matter at 325° F. in 5 hrs.....	Less than 3%
	Penetration of residue.....	Greater than $\frac{1}{4}$ of the original penetration
(Test 17a)	Flash-point (Pensky-Martens tester).....	Greater than 350° F.
(Test 21a)	Soluble in carbon disulphide:	
	In the case of Trinidad asphaltic cement.....	Greater than 65%
	In the case of other asphaltic cements.....	Greater than 95%
(Test 21b)	Non-mineral matter insoluble:	
	In the case of all asphaltic cements.....	Less than 3%
(Test 21c)	Mineral matter:	
	In the case of Trinidad asphaltic cement.....	Less than 35%
	In the case of other asphaltic cements.....	Less than 4%
(Test 22)	Carbenes.....	Less than 2%
(Test 23)	Solubility of non-mineral constituents in 88° naphtha.....	Greater than 70%

Typical asphaltic cements prepared from Trinidad and Bermudez asphalts, respectively, by fluxing the refined asphalt with a residual oil derived from a mixed-base petroleum test as follows:

	Asphaltic Cement Prepared from Trinidad Asphalt.	Asphaltic Cement Prepared from Bermudez Asphalt.
(Test 7)	Specific gravity at 77° F.....	1.26
(Test 9b)	Penetration at 115° F.....	180
	Penetration at 77° F.....	65
	Penetration at 32° F.....	15
(Test 9c)	Consistency at 115° F.....	2.6
	Consistency at 77° F.....	7.9
	Consistency at 32° F.....	53.7
(Test 9d)	Susceptibility factor.....	45.2
(Test 10b)	Ductility at 115° F.....	15
	Ductility at 77° F.....	21.5
	Ductility at 32° F.....	1
(Test 11)	Tensile strength at 115° F.....	0.25
	Tensile strength at 77° F.....	0.75
	Tensile strength at 32° F.....	15
(Test 15a)	Fusing-point (K. and S. method).....	115° F.
(Test 15b)	Fusing-point (B. and R. method).....	133° F.
(Test 15c)	Fusing-point (Cube method).....	148° F.
(Test 16a)	Volatile matter at 325° F. in 5 hrs...	2.5%
(Test 17a)	Flash-point.....	398° F.
(Test 19)	Fixed carbon.....	6.1
(Test 21a)	Soluble in carbon disulphide.....	65.7%
(Test 21b)	Non-mineral matter insoluble *.....	4.8%
(Test 21c)	Mineral matter.....	29.5%
	Total.....	100.0%
(Test 22)	Carbenes.....	0.4%
(Test 23)	Non-mineral matter insoluble in 88° naphtha.....	71.2%

* Including water of hydration (see p. 113).

Paving cements have been patented composed of mixtures of gilsonite and residual oil having a penetration at 77° F. of 50 to 100¹; also mixtures of native

¹ U. S. Pat. 981,225 of Jan. 10, 1911 to Clifford Richardson.

asphalts carrying loosely combined sulphur-compounds heated together with vulcanizable vegetable oils.¹

Preparing and Applying the Wearing or Surface Course. The aggregate should be heated to a uniform temperature between 250 and 375° F., the asphaltic cement to a temperature between 250 and 350° F., and the two mixed together in the required proportions. A special form of mixer used for this purpose is illustrated in Fig. 117. The mixing is continued

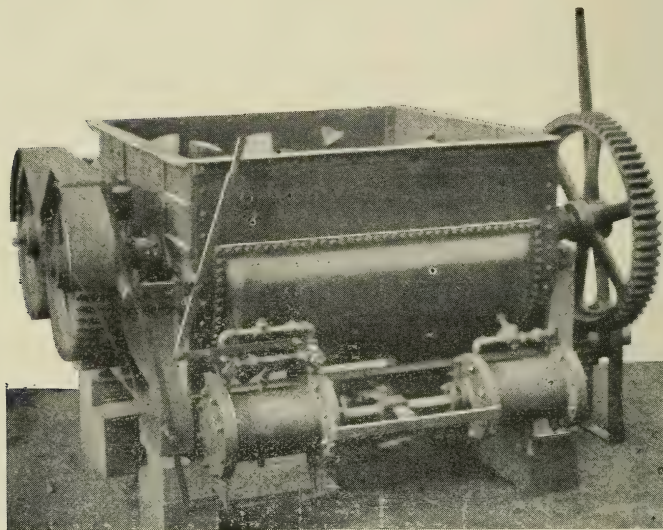

FIG. 117.—Mixer for Preparing Paving Compositions.

for at least two minutes. The mixture is brought to the street in covered wagons, deposited at not less than 225 to 275° F. and raked into a layer which after compression with a roller weighing 8 to 10 tons, will form a wearing surface of uniform thickness from 1 to 2½ in. depending upon the conditions to which the road will be subjected. Before the final rolling, the surface should be dusted with Portland cement or other fine powder.

The deterioration of sheet asphalt pavements is due to:

- (1) Defective construction, including improper proportioning of the ingredients.
- (2) The actual wear and tear of traffic.
- (3) Aging due to exposure to the elements.

¹ U. S. Pat. 1,163,593 of Dec. 7, 1915 to C. N. Forrest.

(4) Unfavorable environment including severe climatic conditions, water, illuminating gas, etc.

These defects, due to one cause or another will manifest themselves by cracks, general disintegration of the surface, formation of waves, depressions, holes, chipping or peeling of the wearing course, etc.

Asphalt Block Pavements. These are similar in composition to the wearing course of sheet asphalt pavements, and in addition contain small broken stone or grit passing a $\frac{1}{4}$ -in. screen but retained on a 10-mesh sieve, also fine filler. The Topeka specifications (p. 364) have been largely used for this purpose. It is advisable that there should be present at least 20 per cent of filler passing a 200-mesh sieve, and not more than 3 per cent of grit retained on a $\frac{1}{4}$ -in. screen. The aggregate should accordingly be composed of a mixture of grit, sand (or mixture of sands) and filler, in such proportions as to secure the minimum percentage of voids.¹

From 6 to 9 per cent of asphaltic cement should be used, having a lower penetration than the cement used in the surface mixture of sheet asphalt pavements (p. 370) but of a higher fusing-point (i.e., 175 to 200° F., B. and R. method, Test 15b) to prevent the blocks becoming distorted during transportation, or when exposed in piles to the heat of the sun.

The blocks usually measure 12 in. long by 5 in. wide, and either 2, 2 $\frac{1}{2}$, 3, 4 or 5 in. deep. They are made by compressing in molds at a moderately high temperature (300° F.) under a pressure of 2 to 3 tons per square inch. Their specific gravity at 60° F. should not be less than 2.50 if trap-rock grit is used, nor less than 2.35 when the grit is composed of limestone.

Foundation or Base. Asphalt blocks may be laid on a foundation consisting of gravel, macadam or preferably concrete. The foundation course should be covered with a "cushion" or "bedding course," composed either of sand 1 in. thick, or cement mortar $\frac{1}{2}$ in. thick, and the blocks embedded in the latter before it commences to set.

Laying the Blocks. Blocks are laid close together, resting on the 12 by 5-in. surfaces extending lengthwise across the street, the joints being broken 4 in. They should be wedged together as firmly as possible to close the joints between them, and rammed into place. After being laid, the blocks are given a light coat of sharp, fine sand, well broomed into the joints, and the pavement opened to traffic in three to four days.

Asphalt blocks have improved greatly in the last few years and are now capable of withstanding severe traffic conditions without fracturing. They are slightly more expensive than a sheet asphalt pavement, but permit repairs being effected more readily, and insure a more uniform composition also a greater freedom from structural faults.

¹ U. S. Pat. 853,116 of May 7, 1907 to Clifford Richardson.

The great difficulty encountered in proportioning the blocks is to manufacture them sufficiently hard and infusible to withstand transportation, and at the same time prevent the pavement being brittle in service. This may be effected by using a binder having a moderate penetration and a high fusing-point. When properly made, the blocks will weld together after a time, upon being subjected to traffic, so that the joints between them will become almost invisible. Sometimes they are anchored in place with metal rods to prevent the blocks shifting. If the binder is too hard and brittle, instead of the blocks welding, the edges will chip and spall. On the other hand, if the binder is too soft or fusible, the blocks will lose their shape, becoming distorted, even before they are laid in place.

Asphalt tiles suitable for paving floors and sidewalks are prepared in a similar manner. They are stamped out in square or hexagonal units. The large square ($8 \times 2\frac{1}{4}$ in.) or hexagonal ($10 \times 2\frac{1}{4}$ in.) tiles are laid on a foundation consisting of 6 to 8 in. of gravel and sand, and the small hexagonal tiles (6×1 in.), are laid on a 3-in. foundation, in either case surfaced with $\frac{1}{2}$ in. of mortar.

Asphalt Mastic Foot-pavements and Floors. In the United States, asphalt mastic is restricted to the construction of foot pavements and floors, for waterproofing railway bridges (p. 432), also for lining reservoirs and tanks. In composition, it is similar to the Topeka asphaltic concrete (p. 364), but it contains a larger percentage of asphaltic-cement, so that it may be laid with greater facility. It is differentiated from bituminous concrete, sheet asphalt pavements, etc., by the fact that the asphalt mastic on being heated forms a thick and slowly flowing mass which may be *poured* into place. The mixture on being allowed to cool partially, is compressed by hand-trowelling to a smooth surface. Asphaltic concrete and sheet asphalt pavements on the other hand, do not melt when heated, but form an adherent, powdery mass, which upon being shovelled into place and raked smooth, require compression underneath heavy rollers, to properly compact them.

Asphalts Used. Asphalt mastic work constituted the earliest type of asphalt pavement (p. 15), and few changes have been made in its mode of application since the inception of the industry. The first products used in asphalt mastic construction were the native "rock asphalts," including Val de Travers, Limmer, Seyssel, and later on Ragusa. The refined rock asphalt (previously heated to expel the moisture and volatile oils) was first "cooked" over an open fire in a suitable melting tank provided with a stirrer, and combined with a purer native asphalt, as for example Trinidad (of which about 8 or 10 per cent was used), Bermudez, or with a residual asphalt, so the finished batch carried 12 to 18 per cent of pure asphalt, the balance being composed of finely divided mineral matter (calcium carbonate, silica, iron and aluminium oxides, etc.). The cooking was performed at 350 to 400° F. The mass was then run into suitable molds and thus cast into flat cakes weighing 50 to 60 lb. each, customarily

stamped with the name of the asphalt used. These cakes were known as "rock asphalt mastic." To-day they are prepared from Trinidad asphalt, mixtures of asphaltites and flux, blown petroleum asphalts and residual asphalts, combined with calcium carbonate or finely powdered silica, all the ingredients being combined at once in a portable rotary mixer. The native rock asphalts first mentioned are all still being used abroad.

The cakes of mastic upon being transported to the place where they are to be used, are melted with an additional quantity of "flux,"¹ and mixed with sand and fine gravel or "grit," in the proportion of about $\frac{2}{3}$ to $\frac{1}{3}$.

A brand of mastic flooring prepared from a mixture of asphaltite and residual oil, which has given very good results in service, was found on analysis to contain 15 per cent of pure asphalt, which in turn tested as follows:

(Test 9a)	Penetration at 115° F.....	30
	Penetration at 77° F.....	11
	Penetration at 32° F.....	10
(Test 9c)	Consistency at 115° F.....	13.0
	Consistency at 77° F.....	25.7
	Consistency at 32° F.....	55.4
(Test 9d)	Susceptibility factor.....	21.5
(Test 15a)	Fusing-point (K. and S. method).....	197° F.
(Test 15b)	Fusing-point (B. and R. method).....	219° F.

Methods of Preparation. A well-known manufacturer recommends the following proportions:

"The mixture shall consist by weight of:

Rock asphalt mastic.....	From 55 to 57 parts
Sharp dry sand and grit.....	From 36 to 38 parts
Flux.....	From 9 to 5 parts
Total.....	100 100

"The sand and grit to be dry, sharp and so graded that the voids shall be reduced to a minimum, none of the particles running over $\frac{1}{4}$ -in. in diameter..... these materials to be mixed in mastic kettles in the usual manner (the kettle temperature at no time to exceed 400° F.), and spread at a temperature of from 300° to 325° F..... After spreading and as the hot mastic cools and sets, it shall be lightly sprinkled with hard sand and rubbed up to a smooth surface finish by means of the usual smoothing tools or floats." (Fig. 118).

The rock asphalt mastic contains 16 per cent by weight of pure asphalt, and the finished mixture including the flux is composed of the following:

Pure asphalt.....	17.8- 14.1%
Finely divided mineral matter present in mastic.....	46.2- 47.9%
Sand and grit added.....	36.0- 38.0%
Total.....	100.0-100.0%

¹The "flux" may consist either of refined Trinidad asphalt, or its equivalent (fusing at about 190° F., K. and S method), for hardening mastic floors subjected to high temperatures, or a moderately soft asphalt (fusing between 135 and 155° F., K. and S. method; penetration at 77° F.: 40 to 80; ductility by Dow method at 77° F.: 10 to 30) for softening the mastic where the floors must remain elastic under reduced temperatures.

The quantities required to lay 1 cu. yd. (equivalent to 324 sq. ft. 1 in. thick) are as follows:

	Fluxed Gilsonite Mastic, Lbs.	Limmer or Vorwohle Mastic, Lbs.
Rock asphalt mastic.....	2170-2170	2540-2680
Sand and grit.....	1430-1455	1195-1350
Flux.....	275- 200	165-170
Total.....	3875-3825	3900-4200

The Limmer and Vorwohle rock asphalt mastics contained 15 per cent of pure asphalt, and the finished composition 13.6-14.2 per cent.

The completed mixture contains therefore twice as much asphaltic cement as an asphalt concrete pavement, which accounts for the fact that the mastic may be melted and *poured*. The finely divided mineral matter present in the rock asphalt mastic assumes the role of "filler." The flux is not combined with the rock asphalt mastic in the original process of manufacture because it is necessary to vary the consistency of the mastic for different purposes, by adding a larger or smaller proportion of the flux.

Mastic floors and pavements may be laid over wood, concrete or masonry, in thicknesses varying from 1 to 2 in., depending upon the amount of traffic to which they will be subjected. If the floor is over 1 in. thick, the mastic should be laid in two layers of equal thickness, breaking joints. When laid over wooden floors, a sheet of tar- or asphalt-saturated felt (p. 397) is first applied to prevent any trouble resulting from the wood shrinking underneath the mastic. When used for pavements out of doors, the mastic should be laid on a Portland-cement concrete foundation not less than 3 in. thick.

Additional formulas based on the use of mastic prepared from Trinidad asphalt proportioned so the finished mixture will carry approximately 12 per cent of *pure* asphalt, are included in Table XXXI.

The ingredients are combined in a kettle over direct fire heat, with continual stirring to prevent local overheating or carbonization, or in a mechanical mixing machine having a rated capacity of 185 sq.ft. of finished mastic 1 in. thick per hour. The mixture is dipped from the kettle or mixer with iron buckets and poured upon the dry and properly graded foundation. Its consistency is such that it will flow slowly, and the spreading and smoothing are performed with the trowels, the operation being similar to plastering.

When the flooring is apt to come in contact with acids, in manufacturing establishments or storage battery rooms, the rock asphalt mastic must be prepared with

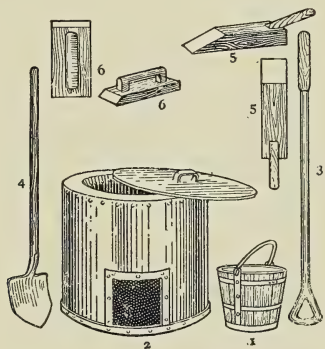

1. Steel hooped wooden pail for measuring sand and grit and for carrying hot mixture.
2. Mixing and cooking kettle.
3. Stirrer for agitating hot mass in kettle.
4. Shovel for taking hot mixture from kettle.
5. Spatula or spreading tool.
6. Float or smoothing tool.

FIG. 118.—Tools for Finishing Mastic Floors.

finely bolted silica as filler in place of calcium carbonate. Where the wear is particularly severe or a specially durable floor or pavement is to be constructed, the mastic is customarily laid on a metal frame or grid, which becomes embedded in the floor and reinforces it in the same manner as the reinforcing metal in concrete. The metal becomes exposed as the floor wears down and retards further attrition.

Asphalt mastic may also be used for constructing foundations of engines, trip-hammers, or other heavy vibrating machinery, to deaden sound and concussion. In this case 40 per cent by weight of the mastic is mixed with 60 per cent by weight of broken stone, and tamped into place. It also finds a particular sphere of usefulness for waterproofing railway bridges subjected to severe vibration (see p. 432).

In Europe, asphalt mastic is also used for finishing the roofs of buildings, applied in two layers totalling $\frac{3}{4}$ to 1 in. thick, also for the construction of subgrade waterproofing, including the "dampcourse" of buildings. It does not, however, give satisfactory results on *vertical* surfaces exposed to the weather.

Bituminized Wood-block Pavements. Creosoted wood-blocks are being used extensively for paving roads, foot-paths, floors of buildings, etc.

Methods of Impregnations. The "Proposed Tentative Specifications for Wooden Paving Blocks" issued by the American Society for Testing Materials, 1917, provide that:

"The wood, which shall be treated, shall be Southern yellow pine, Douglas fir, tamarack, Norway pine, hemlock, or black gum. Only one kind of wood shall be used in any one contract. The blocks shall be sound and must be well manufactured, square-buttcd, square-edged, free from unsound, loose or hollow knots, knot holes, worm holes, and other defects such as shakes, checks, etc., that would be detrimental to the blocks.

The number of annual rings in the 1-in. which begins 2-in. from the pith of the block shall not be less than six, measured radially; provided, however, that blocks containing between five and six rings in this inch shall be accepted if they contain $33\frac{1}{3}$ per cent or more summerwood. In case the block does not contain the pith, the 1-in. to be used shall begin 1-in. away from the ring which is nearest to the heart of the block. The blocks in each charge shall contain an average of at least 70 per cent of heartwood. No one block shall be accepted that contains less than 50 per cent of heartwood."

The size of the blocks ranges as follows:

Depth between 3 and 4 in. depending upon the severity of the traffic to which they are to be subjected, usually 3 in. for light traffic, $3\frac{1}{2}$ for medium and 4 in. for heavy traffic conditions.

Width should be *uniform* for any particular pavement, but may vary between 3 and 4 in. The best practice provides that there should be a difference of not less than $\frac{1}{4}$ in. between the width and the depth, which under no circumstances should be made equal.

The length will vary in any particular lot, between 5 and 10 in., averaging about 8 in. Blocks 3 in. deep should not exceed 8 in length, blocks $3\frac{1}{2}$ in. deep should not exceed 9, and blocks 4 in. deep should not exceed 10.

After removing the bark, the wood is cut into planks equalling in thickness the width of the finished block. The planks are then run through a planer, trimming them all to *exactly* the same size (insuring a uniform width of the finished blocks), and finally through a set of gang-saws, which cuts them into the finished blocks.

Formerly, the wood was seasoned out of doors from four to twelve months, depending upon the kind of wood, its dimensions, the season of the year and the locality. At the present time this process is accelerated by steaming the blocks for two to four hours in steel cylinders varying in size from 6 ft. in diameter by 42 ft. long, to 9 ft. in diameter by 172 ft. long. In this treatment, live steam is introduced at not exceeding 20 lb. pressure per square inch, raising the temperature between 220 and 240° F. After the steaming, the cylinder is subjected to a vacuum of not less than 22 in. maintained for at least one hour, to withdraw the moisture and resinous matters. This is continued until the blocks are thoroughly dry, whereupon the creosote oil heated to 180–220° F., or a mixture containing 80 per cent zinc chloride and 20 per cent creosote¹ is introduced. The pressure is applied gradually, not to exceed 50 lb. at the end of the first hour, nor 100 lb. at the end of the second hour, and then maintained at not less than 100 nor more than 150 lb. until the proper impregnation has been attained. The oil is pumped from the cylinder and the blocks allowed to drain for about a half hour at a temperature of 200° F. under a vacuum of at least 20 in. The quantity of preservative introduced should range between 6 and 12 lb. per cubic foot with blocks used for floors, and from 12 to 20 lb. per cubic foot, averaging 16 lb., with blocks used for paving roads. The function of the preservative is twofold, namely:

- (1) To prevent the wood from decaying, due to the ravages of fungi and moulds.
- (2) To waterproof the blocks, preventing them from warping or swelling.

Ten pounds of the preservative per cubic foot are sufficient to preserve the blocks from decay, although a larger quantity must be used to secure the required waterproof properties. To completely waterproof the blocks 25 lb. would be required, which is more than ordinarily used in practice.

Creosote Preservatives. The so-called “creosote” preservatives include the following products:

(1) Distillates from gas-works coal tar or coke-oven coal tar, known commercially as “distillate oil.”

(2) Mixtures of the foregoing “distillate oil” with not exceeding 35 per cent of a gas-works coal tar or coke-oven coal tar, containing preferably 5, but not exceeding 25 per cent free carbon.² Refined or filtered tars are recommended for this purpose.

In using the creosote, care should be taken to prevent it becoming contaminated with water.³

The creosote preservative shall comply with the following specifications, where *A* and *B* represent a pure distillate from gas-works coal tar or coke-oven coal tar; and where *C*, *D* and *E* represent *mixtures* containing at least 65 per cent distillate oil from gas-works coal tar or coke-oven coal tar, and the balance a low carbon gas-

¹ U. S. Pat. 815,404 of Mar. 20, 1906, to J. B. Card.

² *Proc. Am. Wood. Pres. Assoc.*, 16, 825, 1915.

³ *Ibid.*, 827, 1915.

works coal tar or coke-oven coal tar. Specifications *A* and *C* are published by the Committee on Wood Preservation¹; *D* by the Committee on Standard Specifications of the Creosoted Wood Paving Block Bureau²; whereas *B* and *E* constitute tentative specifications of the American Society for Testing Materials.³

	<i>A</i>	<i>B</i>	<i>C</i>	<i>D</i>	<i>E</i>
Sp.gr. at 38° C. (Test 7 <i>d</i>).....	>1.06	>1.06	1.06-1.12	1.07-1.11	1.07-1.14
Viscosity (Engler method) at 82° C./20° C. (Test 8 <i>a</i>)	<1.15	<1.15	<1.3	<1.2
Fixed carbon (Test 19).....	<2%	<10%
Distillation test (Test 20):					
Up to 210° C.	<5%	<5%	<5%	<5%	<5%
Up to 235° C.	<15%	<15%	<30%	<30%	<25%
Up to 315° C.	35-70%	>50%
Up to 355° C.	>65%	>70%
Sp.gr. distillate 235-315° C. at 38° C./15.5° C..	>1.02	>1.03	>1.02	>1.03	>1.03
Sp.gr. distillate 315-355° C. at 38° C./15.5° C...	>1.09	>1.09	>1.08	>1.08	>1.09
Sp.gr. residue above 355° C. at 25° C./15.5° C...	*	*	†	>1.23‡	†
Insoluble in hot benzol (Test 24).....	<0.5%	<0.5%	<3%	<2.5%	<3%
Water (Test 25).....	<3%	<3%	<3%	<3%	<3%

* If >10%, the residue shall have float test at 70° C. of <50 seconds.

† If >35%, the residue shall have float test at 70° C. of <80 seconds.

‡ If residue is crystalline, granular and non-ductile, it shall have a specific gravity of <1.14 at 25° C./15.5° C.

The city of Chicago specifies: (1) That the creosote oil shall have a specific gravity of 1.10-1.14; (2) less than 22 per cent shall distil below 235° C., and less than 40 per cent below 315° C.; (3) the residue after distillation to 355° C. shall be plastic and *not* brittle at 77° F., and shall produce a *clear* amber-colored spot on filter paper when warmed; (4) the distillate obtained between 250° and 315° C. shall contain not less than 5 per cent of tar acids nor more than 1½ per cent of unsaponifiable matter.

Mixtures of distillate oil with a certain proportion of refined tar are supplanting the use of the oil alone, for the reasons that:

- (1) They are less expensive.
- (2) They waterproof the blocks more efficiently.
- (3) They volatilize less readily.

The presence of too much tar in the creosote mixture interferes with the penetration, due to the fact that the tar has a greater viscosity than the distillate oil at high temperatures. An excess of free carbon in the tar will clog the pores of the blocks and similarly interfere with the penetration.

Foundation Course. This will vary in thickness depending upon the traffic, consisting of a Portland-cement concrete 5 to 9 in. thick, usually averaging 6 in. A 1 : 2½ : 5 concrete with a smooth-trowelled finish is recommended.

Cushion Layer. The best practice requires the blocks to be embedded either in a "cushion" or Portland-cement mortar, or a thick coating of tar and sand. Where mortar is used, the blocks are laid in

¹ *Proc. Am. Wood. Pres. Assoc.*, 29, 1916.

² *Proc. Am. Wood Pres. Assoc.*, 2, 44, 1915.

³ *Proc. Am. Soc. Testing Materials*, 1917, Standards.

a 1 : 4 Portland cement mortar $\frac{1}{2}$ to 1 in. thick.¹ The mortar should be prepared as dry as possible and the blocks rammed into place, forming a level surface free from depressions. The pavement must be closed to traffic until the cement mortar sets.

Where the blocks are to be embedded in a tar cushion, a thick coating of heated tar is spread on the concrete foundation and while hot sprinkled with sand, forming a mastic into which the blocks are rammed.

The English practice, which now seems to be gaining favor in this country, consists in constructing the foundation course as smooth and level as possible, laying the blocks in place, and pouring hot tar between the crevices. The tar will first work its way underneath the blocks and cement them to the foundation, and the pouring is continued until the joints are filled half way to the surface. The joints are then filled with a grout of Portland cement. This procedure prevents "bleeding."

The blocks may be laid in rows either perpendicular to the curb, or at angles varying from 45° to $67\frac{1}{2}^\circ$, the latter having the advantage of conforming to the expansion and contraction of the pavement without the necessity of providing transverse expansion joints. Where the blocks are laid at right angles to the curb, $\frac{1}{2}$ in. transverse expansion joints (page 384) should be introduced every 50 or 60 ft. In all cases, an expansion joint $\frac{3}{4}$ in. wide, should be provided between the blocks and the curb, composed either of a preformed bituminous strip (p. 383) or a melted bituminous mixture having a penetration of 30-40 at 77° F. (Test 9b). The blocks must be laid as close together as possible, with joints not exceeding $\frac{1}{8}$ in., and levelled with a roller weighing not less than 4 tons.

Filling the Joints. Three types of fillers are employed for wooden paving blocks, viz.: sand, Portland-cement grout or a melted bituminous composition. The last named is used most frequently.² When dry sand is selected, it should be of a fine texture and spread with a broom. Sand is the least efficient form of filler, but in time it will mix with the creosote oil or tar exuding or "bleeding" from the blocks, and form a mastic between the joints.

Portland-cement grout should be composed of equal volumes of cement and fine sand, made up with water to a fairly liquid consistency, and after being swept into the joints, the pavement should be closed to traffic until it sets.

The characteristics of the bituminous filler will be described on p. 382. It is swept on the surface in a melted condition, and has the advantages of augmenting the waterproof properties of the blocks, at the same time providing for their expansion and contraction. The bituminous filler is covered with sand or chips or with a cement grout, to obviate any tendency of the pavement tracking.

¹ Eng. Record, 73, 154, 1916.

² U. S. Pat. 71,746 of Dec. 3, 1867 to Alexander Hamar.

General Considerations. A wood-block pavement when properly constructed is extremely durable even under heavy traffic; it may readily be repaired and is less noisy than any other bituminous pavement. The disadvantages are its slipperiness in damp or snowy weather, and the fact that under certain conditions it is apt to "bleed." The latter manifests itself by the soft bituminous matter exuding in summer, and being readily tracked about.

Bleeding is caused by introducing too large a proportion of the creosote mixture into the blocks, and is likely to occur when more than 16 lb. are used per cubic foot. It will also occur when the pavement is not provided with expansion joints, in which event the compression brought about by expansion, will squeeze some of the creosote from the pores of the blocks.

Bituminous Fillers for Wood, Brick and Stone Pavements. A "bituminous filler" is the name applied to a bituminous substance introduced into the joints of wood-block or brick or stone pavements by melting and pouring. It must adhere to the bricks or blocks in cold weather without loosening or chipping under the impact of traffic, or when subjected to strains brought about by contraction or settling of the pavement. The filler must accordingly possess great adhesive strength and ductility, and must also be sufficiently resistant to high temperatures not to exude from the surface, or run out of the joints.

Characteristics of Bituminous Materials Used. The same classes of bituminous materials have been used for fillers as the bituminous cements of bituminous concrete pavements (p. 365), and they should comply with the following characteristics:

	Asphaltic Fillers.	Pitch Fillers.
(Test 9b) Penetration at 115° F.....	<150
Penetration at 77° F.....	25-60
Penetration at 32° F.....	>20
(Test 10a) Ductility at 115° F.....	>50	> 50
Ductility at 77° F.....	>10	> 10
Ductility at 32° F.....	>½	> ½
(Test 11) Tensile strength at 115° F.....	>0.25	>0.25
Tensile strength at 77° F.....	>2.5	>2.5
Tensile strength at 32° F.....	>7.5	>7.5
(Test 15a) Fusing-point (K. and S. method).....	140-160° F.
(Test 15b) Fusing-point (B. and R. method).....	160-180° F.
(Test 15c) Fusing-point (Cube method).....	130-140° F.
(Test 16a) Volatile at 325° F. in 5 hrs.....	<2%	<5%
Volatile at 500° F. in 4 hrs.....	<5%	<8%
(Test 17a) Flash-point.....	>350° F.	>350° F.
(Test 20) Distillate under 600° F.....	<8%
(Test 21a) Soluble in carbon disulphide.....	>98%	60-80%
(Test 21b) Non-mineral matter insoluble.....	<2%	20-40%
(Test 21c) Mineral matter.....	<1%	<1%
(Test 22) Carbenes.....	<2%	<5%
(Test 23) Soluble in 88° naphtha.....	65-75%

N.B. Pitch fillers in view of their low fusing-point should *only* be used where the joints between the bricks or blocks are to be filled with fine gravel, which will serve to hold the pitch in place.

Filling the Joints. With brick and stone block pavements, the courses should be laid with joints $\frac{3}{8}$ to $\frac{1}{2}$ in. wide. When a pitch filler is to be used, the joints are half filled with $\frac{1}{8}$ to $\frac{3}{8}$ in. hot gravel (containing not over 25 per cent of the $\frac{3}{8}$ -in. size). Before the gravel cools, the joints should be filled half way to the top with filler, then to within $\frac{1}{2}$ in. of the surface with hot gravel, and lastly poured full with filler. In performing the work, the pitch should be heated from 250 to 325° F., but never exceeding the latter. When asphaltic filler is used, sand or gravel are unnecessary. The filler is heated from 300 to 450° F. and poured into the joints until completely filled. A top dressing of sand should be spread over the filler while hot to form a wearing surface.

The joints of wood-block pavements are formed as closely as possible, and the melted filler poured over the entire pavement and worked into the joints until flush by scraping with a wooden or rubber squeegee, or a broom, whereupon the entire pavement is sprinkled with fine sand or gravel.

Bituminous Expansion Joints. These are composed of bituminous strips $\frac{1}{4}$ to $1\frac{1}{4}$ in. thick, made up with or without a felted or woven fabric or metal reinforcement. They are used in connection with concrete or block pavements and installed between the pavement and curbs, also transversely across the pavement to take up the expansive and contractive stresses and strains. When expansion joints are not used, a concrete pavement will crack in cold weather because of the inelasticity of the concrete, and have a tendency to buckle or bulge in hot weather.

Modern practice calls for longitudinal expansion joints along the curbs, and transverse joints spaced at intervals of 40 to 75 feet. The width of the expansion joint should equal the thickness of the pavement (3 to 8 in.)

Four types of bituminous expansion joints are in use, viz.:

(1) *Premoulded Strips of high Fusing-point Bituminous Compositions.* These¹ consist of blown asphalt of a high fusing-point (50 parts) mixed with sand (50 parts) and shoddy-dust (25 parts); or of a bituminous mixture² cast in moulds 6 ft. long, whose thickness corresponds to the size of the joints ($\frac{1}{4}$ to $1\frac{1}{4}$ in.) and width to the thickness of the pavement (3 to 6 in.). The approved mixture consists of grahamite 21 per cent, residual oil derived from non-asphaltic petroleum 49 per cent, and soft native asphalt 30 per cent. The presence of the soft native asphalt enables residual oil derived from non-asphaltic petroleum to flux with the grahamite. The fusing-point of the combination should be in excess of 190° F. (Ball and Ring method). The mixture is claimed to possess the required elasticity, cohesiveness and resistance to temperature changes. In winter, however, the strips must be transported very carefully for they would break into small pieces if allowed to drop.

¹ U. S. Pat. 1,134,939 of Apr. 6, 1915 to James Fanwell.

² U. S. Pat. 1,207,524 of Dec. 5, 1916, to C. N. Forrest.

Longitudinal strips should be $\frac{1}{2}$ in. thick for streets less than 20 ft. wide, $\frac{3}{4}$ in. for streets 20–30 ft., 1 in. for streets 30–40 ft. and $1\frac{1}{4}$ in. for streets over 40 ft. wide, placed parallel with, and at each curb line. Transverse joints $\frac{1}{4}$ to $\frac{1}{2}$ in. thick should be spaced not less than 40 ft., and extend the full width of the brick, wood, stone block or concrete pavement.

A proprietary product composed of gilsonite fluxed with blown petroleum asphalt tests as follows:

(Test 9b)	Penetration at 115° F.....	50–60
	Penetration at 77° F.....	35–40
	Penetration at 32° F.....	20–30
(Test 15b)	Fusing-point (B. and R. method).....	240–255° F.
(Test 21a)	Soluble in carbon disulphide.....	99.5%

The Commission of Highways of the State of New York, in specifications issued April 1, 1916, stipulate that the expansion joint should project at least $\frac{3}{8}$ in. above the finished surface of the pavement at all transverse joints. They also specify the premoulded joint to test as follows:

(Test 7)	Specific gravity at 77° F.....	0.98–1.05
(Test 9b)	Penetration at 115° F.....	Less than 45
(Test 9b)	Penetration at 77° F.....	15–35
(Test 9b)	Penetration at 32° F.....	Greater than 12
(Test 15b)	Fusing-point (B. and R. method).....	220–250° F.
(Test 16)	Volatile matter 5 hrs. at 325° F.....	Less than 1%
(Test 21a)	Soluble in carbon disulphide.....	Greater than 98.5%
(Test 24)	Soluble in carbon tetrachloride.....	Greater than 99.8%
(Test 24)	Soluble in 76° naphtha.....	50–75%

A modification consists in comingling felted fibres with the bituminous matter in the presence of water, by forcing them through a perforated plate, and after evaporating the water, moulding the mixture to form the joint.¹

(2) *Joints Composed of a Thick Layer of Bituminous Material Reinforced on Either Surface with Sheets of Plain or Bituminized Fabric.* This joint is composed of two layers of untreated felted fabric,² or woven fabric impregnated with asphalt³ (page 408) and carrying a relatively thick layer of bituminous composition between, similar to the foregoing. The function of the fabric is to strengthen the joint, and enable it to be transported in cold weather without danger of fracturing, thus overcoming the objection against the foregoing type. The bituminous layer in the centre should have a high fusing-point (above 185° F., K. and S. method) and preferably a low susceptibility factor. It may be composed of asphaltic constituents, sometimes mixed with 25 to 50 per cent of finely divided mineral matter (calcium carbonate, shale, clay, silica, fuller's earth or slate), or from 15 to 30 per cent by weight of ground wood ("wood flour") or fibrous matter. The function of the filler is to increase the toughness and resistance of the mixture to temperature changes (see page 346), and in certain cases to reduce the cost.

The joint is manufactured in a continuous sheet on a form of roofing machine (p. 405), in which the two layers of bituminous felt previously impregnated with saturant (p. 395) are fastened together by introducing the melted or plastic bituminous composition in between, carefully adjusting the thickness of the assembled sheet

¹ U. S. Pats. 1,156,122 of Oct. 12, 1915, 1,166,166 of Dec. 28, 1915 and 1,240,524 of Sept. 18, 1917, to J. C. Woodley; 1,177,267 of Mar. 28, 1916 to R. P. Perry.

² U. S. Pat. 1,040,093 of Oct. 1, 1912 to James Adkins, Jr.

³ U. S. Pat. 1,248,909 of Dec. 4, 1917, to H. B. Pullar.

to correspond with that of the joint desired. The width of the sheet should similarly correspond to the length of the completed joint (usually 6 ft.). When the assembled sheet has cooled, it is cut transversely with mechanically actuated knives, into strips 3 to 6 in. wide, depending upon the thickness of the pavement for which they are intended. In cross-section a paving joint of this type corresponds with "Type E," Fig. 199 (p. 561), with the intermediate layer of substantial thickness and coatings omitted.

(3) *One or More Layers of Bituminized Fabric, the Latter Cemented with a Bituminous Adhesive.* One form of paving strip is composed of a single layer of tarred felt (p. 395);¹ another consists of a strip of a woven fabric saturated and coated with asphalt, having particles of cork or sawdust embedded on the surfaces²; and still another is composed of three or more layers³ of asphalt-saturated felt (p. 395) cemented together with comparatively thin layers of an asphaltic adhesive. The strip when assembled varies from $\frac{1}{4}$ to $\frac{3}{4}$ in. thick, and the raw felt sheets range from No. 50 to No. 75 on the felt marker's scale (p. 389).

In manufacturing this form paving joint, one or more webs of felted fabric are first impregnated individually with melted asphalt, usually quite soft in consistency (fusing-point 90–140° F., K. and S. method), and are then joined by comparatively thin layers of a harder asphaltic mixture (fusing-point 140–180° F., K. and S. method). The outer surfaces are not coated. The width of the web corresponds to the length of the paving joints (usually 6 ft.). After the webs are sealed together and allowed to cool, they are cut into strips corresponding to the thickness of the pavement.

(4) *Armored Bituminized Fabric.* Another type of paving joint adapted solely for concrete roads, known as an "armored joint," consists of a layer of bituminized fabric reinforced on either side by a thin metal plate. The joint may either be flat or corrugated,⁴ and the upper part constructed with flanges or projections to protect the edges of the adjacent concrete sections.

Another modification is composed of a strip of high fusing-point bituminous composition (similar to type 1) reinforced in the centre with a metallic core of wire-mesh.⁵ Still another consists of a strip of high fusing-point bituminous composition protected on the surface with a trough-shaped shell of wire mesh to which in turn paper or cloth is cemented fast.⁶

¹ U. S. Pat. 105,599 of Jul. 19, 1870 to J. J. Schillinger.

² U. S. Pat. 635,176 of Oct. 17, 1899 to T. K. Muir.

³ U. S. Pat. 1,220,766 of Mar. 27, 1917 to W. J. Moeller.

⁴ U. S. Pat. 1,241,405 of Sep. 25, 1917, to Willis E. Leach.

⁵ U. S. Pat. 1,078,982 of Nov. 18, 1913 to James Banwell.

⁶ U. S. Pat. 1,085,275 of Jan. 27, 1914 to W. P. Lonsdale.

CHAPTER XXV

BITUMINIZED FABRICS FOR ROOFING, FLOORING, WATER-PROOFING, SHEATHING AND INSULATING PURPOSES

SHEET ROOFINGS

THESE are composed of a single layer or a plurality of layers assembled together, each composed of a woven or felted fabric, saturated, coated or both saturated and coated with bituminous compositions, and in special cases reinforced with metal. The finished structure may be supplied in flat sheets or wound up in rolls of suitable length and width. These fabrics and bituminous mixtures may be assembled in innumerable combinations.¹

Felted Fabrics. These are generally formed of rag or asbestos fibres, with or without additions, on a machine similar to that used for manufacturing paper. If rags are employed, they are first run through a series of revolving knives known as "cutters," which shred them into small fragments, and then into the "beaters," where they are ground into a pulp with water. A beater separates the strands forming the cloth into the individual fibres without materially shortening them. A charge is beaten one-half to three hours until all the lumps have been broken up, whereupon the "pulp" is passed through a "screen" to remove any foreign particles, and then run on the felt machine (Fig. 119), where it is formed into a sheet of predetermined thickness. Cylinders 1 and 2, covered with fine wire cloth, are partly immersed in the tanks *T-T* containing the beaten rag fibres suspended in water. As the cylinders revolve, the wire cloth acts as a strainer and picks up a layer of fibres, letting the water run to waste. The machine is equipped with three endless webs of cloth, 3, 5 and 16. Cloth 5 is first pressed in contact with cylinder 1 by the couch roll 11, causing the fibres to adhere to the cloth. Cylinder 2 similarly adds a layer of fibres under pressure

¹ *References.* "Ready Roofing Mists and Mysteries," by The Northwestern Lumbermen's Association, Minneapolis, Minn., 1911; "Roofing Materials Committee Report," *Bull. Am. Ry. Eng. Assn.*, 14, 839, 1913; "What is your Market—an Analysis of the Roofing Situation," by C. D. Mercer, Curtis Publishing Co., Sept., 1916; "Die Fabrikation der Dachpappe und der Anstrichmasse für Pappdächer," Dr. E. Luhmann, 2d Edition, Vienna, 1902; "Wie eine Moderne Teerdestillation mit Dachpappenfabrik eingerichtet sein muss," by Willy Peterson-Kinberg, Vienna, 1904.

of the couch roll 12. The suction box shown alongside rollers 11 and 12 draws the surplus water from the newly formed sheet of felt, which then passes between cloths 3 and 5, where it is subjected to gradually increased pressure by the rolls 13 and 14. At roll 14, the upper cloth 3 returns, while cloth 5 carries the sheet of felt to 15, where the felt now just strong enough to hold together, leaves cloth 5 and passes between pressure rolls against the third cloth 16. The felt is now carried over a series of steam rolls 8, of which modern felt machines are equipped with 55 to 65. These expel the remaining moisture, whereupon the sheet is given a smooth surface by the calender rolls 9, and wound into rolls at 10, while at 10' the wide sheet is slit into narrower sheets either 32 or 36 in. wide, and automatically rewound into rolls by the winders shown at the extreme right.

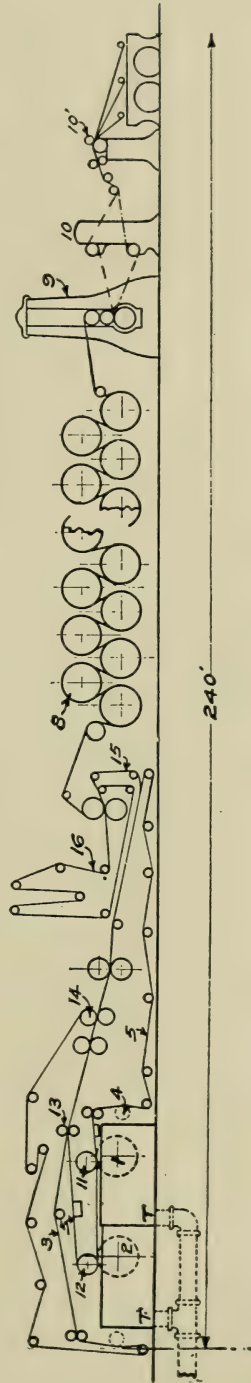

FIG. 119.—Machine for Manufacturing Roofing Felt.

The Felt Manufacturers' Association of the United States recognizes six classes of raw materials for making roofing felt, viz.:

No. 1, Roofing Rags. These constitute soft rags carrying a percentage of wool, and include satinet garments, men's coats, pants, vests, mixed linsies, seams, women's coats, sacks and cloth skirts.

No. 2, Roofing Rags. These consist of cotton rags, and include large and small cotton rags, linings (without seams), silk rags, rag carpets, print rags and stockings.

No. 3, Gunny Bagging. These include bags and sacks free from fertilizer, charcoal, coal, cement, chemicals, lime and plaster.

No. 4, Carpets. These include Brussels and hard-back carpets.

No. 5, Roofing Rags. This class includes: (a) tailor rags free from all rubbish and paper; (b) tailor rags containing not over 10 per cent paper; (c) tailor rags containing over 10 per cent but not exceeding 50 per cent of paper.

No. 6, City Dump Rags. Including rags of all sorts, and of variable composition.

Miscellaneous Materials. Including canvas, window shades, strings and buckram.¹

The following fibres are present in the foregoing classes of materials:

True rag fibres, including: (1) cotton and linen fibres; (2) wool and silk fibres; (3) jute and manila fibres.

Paper fibers, including: (1) mechanical (i.e., ground) wood pulp; (2) chemical wood pulp (sulphite and sulphate).

No. 1 rags, contain cotton (and linen) also a percentage of wool (and silk) fibres.

No. 2 rags, contain mostly cotton fibres.

No. 3 rags, contain cotton, also a percentage of jute and manila fibres.

No. 4 rags, contain mostly jute and manila fibres.

No. 5 rags, contain cotton and wool with or without paper fibres.

No. 6 rags, contain a mixture of all the fibres present in the previous classes.

The various classes of rags are mixed in suitable proportions in the manufacture of roofing felt. Classes 1 and 2 tend to "soften" the felt, and open up its pores thereby enabling it to absorb a larger percentage of bituminous saturation. Classes 3, 4 and 5 tend to "harden" the felt and make it less pliable, less absorbent and denser. Class 6 acts variably, depending upon the composition of the rags used. It is customary to mix Classes 1 and 2 with Classes 3, 4, 5 and 6 in proportions ranging from 5 : 1 to 1 : 2, depending upon the nature of the rags available, and the quality of the felt to be manufactured.

A *high grade* roofing felt made up approximately of 75-80 per cent "soft" rags and 20-25 per cent "hard" rags, will show the following composition on examining the finished sheet microscopically (see p. 568):

Cotton fibres.....	50-70%
Wool fibres.....	10-20%
Jute and manila fibres.....	5-15%
Wood fibres (paper).....	1-5%

Roofing felt is often spoken of as "wool felt," but this term is somewhat of a misnomer, since no roofing felt is composed *entirely* of wool fibres. It is impractical to manufacture roofing felt from wool fibres alone, as they are so soft and fluffy that they will not form a satisfactory sheet on a felt machine. It is necessary to have other fibres present, to produce a strong, compact sheet, not to break on the calender rolls or dryers, and to absorb the proper percentage of bituminous saturation afterwards.

The durability of the various fibres is in exact proportion to their prices. Their comparative costs, taking wool as 100, are approximately as follows:

Wool.....	100
Cotton.....	60
Jute and manila.....	44
Paper (including mechanical and chemical wood fibres).....	20

Wool fibres are most durable and least affected upon contact with moisture or the sun's rays. Nature provides wool for covering animals to protect them against exposure to the elements. Cotton fibres come next in durability. It is significant that cotton has always been used for making sail-cloths and covering porches or

¹The association names the following materials as being unsuited for manufacturing roofing felt, viz.: shoe cuttings, felt boots, corsets, suspenders, oil cloth, matting, leather, rubber, rope, mackintosh clippings, pasted stock, wood, stones, metals of all kinds, tin cans, glass, bottles, ashes, bones, excelsior, etc.

decks of steamers exposed to the weather. Most of us have observed how much more rapidly jute and manila fibres, as for example in the form of burlap bagging, will decay, than cotton or wool. Paper fibres require little comment. Everyone knows that a newspaper soon falls to pieces when left out-of-doors in the sun and rain, chemical wood fibres (sulphite and sulphate) being somewhat more weather-resistant than mechanically ground wood-pulp. Clay is simply used as an adulterant, to add weight to the raw felt, without contributing in the least to its longevity.

The particular kind of fibre present does not influence the strength of the felt, which is controlled largely by the following factors:

(1) The *length* of the fibres in the felt. This is predetermined by:

(a) The length of the fibres, as they existed in the rags.

(b) The extent to which they have been broken up and shortened in the beaters.

(2) The extent to which the rag or paper stock have undergone *eremacausis*. Old rags or papers which have been allowed to rot before being converted into felt will produce a weaker sheet than when new rags or paper are employed.

(3) The skill displayed in "running" the sheet on the felt machine.

Many substitute fibres have been suggested for manufacturing roofing felt, including the following, viz.: leather fibres,¹ cane fibres,² straw fibres,³ asbestos fibres in combination with rag fibres,⁴ cocoa-nut fibres,⁵ sea grass,⁶ ground wood fibres,⁷ red-wood, oak and tan barks,⁸ moss, peat, etc.

Waste paper is used most extensively as a substitute for rag stock. It does not appreciably affect the strength of the felt, but it tends to increase its density, reduce the percentage of bituminous saturation absorbed, make it harder and less pliable, and also less weather-resistant. The author has examined samples of roofing felt containing as much as 65 per cent of paper in admixture with rag stock. Straw also decreases the weather resistance of the felt, making it hard and brittle and bark reduces its tensile strength. Sea grass does not decrease its strength, porosity or brittleness.

Mineral substances, such as clay and slag (mineral) "wool" are often used for adulterating felt. These may be detected by the ash on ignition. If properly made, felt should not yield more than 8 per cent mineral ash. The moisture content of the felt as furnished by the manufacturer should not exceed 10 per cent by weight.⁹

Rag felt is marketed on the basis of its weight in pounds per 480 sq.ft., known as the "number," ranging from 20 to as high as 90. The "number" of the felt multiplied by 0.225 will give its weight in pounds per 108 sq.ft., and when multiplied by 0.208 will give its weight per 100 sq.ft. High grade rag felt will test

¹ U. S. Pats. 40,592 of Nov. 17, 1863 to S. M. Allen; 1,211,837 of Jan. 9, 1917 to C. N. Forrest.

² U. S. Pat. 88,516 of Mar. 30, 1869 to R. W. Russell.

³ U. S. Pat. 854,740 of May 28, 1907 to A. G. Hennion.

⁴ U. S. Pat. 81,641, of Sep. 1, 1868 to H. W. Johns.

⁵ U. S. Pat. 1,237,000 of Aug. 14, 1917 to Herman von Uffel.

⁶ U. S. Pat. 1,226,738 of May 22, 1917 to Herbert Abraham.

⁷ U. S. Pat. 119,601 of Oct. 3, 1871 and 121,166, Nov. 21, 1871 both to J. K. Griffin; 1,188,495 of Jun. 27, 1916 to E. J. Schroder.

⁸ "The Use of Bark for Paper Specialties," by Otto Kress, *J. Ind. Eng. Chem.*, **8**, 883, 1916.

⁹ Determined by distilling a weighed quantity of felt with kerosene, and measuring the volume of water passing over with the distillate.

approximately 1 mil in thickness, and not less than 0.5 lb. on the Mullen strength tester (p. 569), per unit "number." These relations hold approximately constant for all weights.

The following standards have been established by the Berlin Imperial Testing Laboratory.¹

(1) Rags, fibrous textile waste, and waste paper may be used, but the direct addition of wood pulp, straw pulp, peat, sawdust and mineral loading material is forbidden.

(2) The felt must not yield more than 12 per cent of ash.

(3) The moisture content of the air dry felt should not exceed 12 per cent.

(4) Felt when immersed in anthracene oil should not absorb less than 120 per cent by weight.

(5) Felt of normal thickness (at least 400 grams per square meter) should have a breaking weight² (for a strip 15 mm. wide) in the longitudinal direction of at least 3 kilos.

So-called "asbestos felt" is sometimes made from asbestos fibres alone, and sometimes from a mixture of asbestos and rag fibres. It is marketed on the basis of its weight in pounds per 100 sq.ft., and may be manufactured either porous in structure, suitable for saturating purposes, or of a dense structure, for attaching to the surface of prepared roofings. Samples of asbestos felt for saturating purposes examined by the author tested as follows:

6 lb. asbestos felt	13 mils thick
8 lb. asbestos felt	17 mils thick
10 lb. asbestos felt	19 mils thick
12 lb. asbestos felt	23 mils thick
14 lb. asbestos felt	26 mils thick
16 lb. asbestos felt	30 mils thick
40 lb. asbestos felt	70 mils thick

Woven Fabrics. The woven fabrics ordinarily used for manufacturing prepared roofings include burlap or hessian (composed of jute fibres) and duck (composed of cotton fibres). These are marketed in various weights, expressed in arbitrary ways.³ Woven fabrics do not take up nearly so large a percentage of bituminous saturation as felted fabrics, nor is it possible to impregnate them as uniformly, due to unavoidable variations in texture in different portions of the sheet.

Bituminous Saturating Compositions. Bituminous materials suitable for impregnating felted or woven fabrics are usually soft in consistency at room temperature, ranging from semi-liquids to semi-solids, with a

¹J. Marcusson, *Mitt. k. Materialprüf.*, **34**, 40, 1916.

²The "breaking weight" represents the weight required to break a strip of given width.

³Burlaps are designated by the weight in ounces per lineal yard 40 in. wide, and "numbers" 7½, 8 and 10 are generally employed in manufacturing roofings. "Regular" ducks are designated by the weight in ounces per lineal yard 29 in. wide, and "numbers" 6 to 15 are generally used for the foregoing purposes. "Enamelling" ducks are designated by the weight in ounces per lineal yard of the width in which they happen to be supplied (usually 46, 60 or 72 in.), and "numbers" 4 to 16 are ordinarily used. "Numbered" ducks are designated in numbers arbitrarily—number 1 corresponding to a weight of 18 oz. per yard 22 in. wide, and each number greater than 1, to a decrease of 1 oz.; numbers 8 (11 oz. per 36 by 22 in.) to 12 (7 oz. per 36 by 22 in.) being generally used in manufacturing roofings.

penetration of greater than 60 at 77° F. (Test 9b), a consistometer hardness (Test 9c) of less than 15 at 77° F., and a fusing-point by the K. and S. method (Test 15a) between 80 and 140° F., or 95 to 160° F. by the B. and R. method.

The following classes of bituminous substances have been used for this purpose:

Group 1. Pure native asphalts, residual asphalts, blown petroleum asphalt, sludge asphalt, wurtzilite asphalt, wood-tar pitch, rosin, rosin pitch, bone-tar pitch and fatty-acid pitch, used either singly or in various combinations when of the required consistency; or else if too hard (and the same applies also to asphaltites) fluxed to grade with one or more of the following, viz.: soft native asphalts, wax tailings, residual oil, soft residual asphalts, soft blown petroleum asphalt, soft sludge asphalt, soft fatty-acid pitch, animal and vegetable oils or fats, and wool grease.

Group 2. Oil-gas-tar pitch, water-gas-tar pitch, gas-works-coal-tar pitch, coke-oven-coal-tar pitch, wood-tar pitch, rosin, rosin pitch, bone-tar pitch, and fatty-acid pitch, used either singly or in various combinations when of the required consistency; or else if too hard, fluxed to grade with one or more of the following, viz.: the corresponding liquid tar previously evaporated to expel the highly volatile oils; distillates of high boiling-points derived from the respective tars; wax tailings; soft fatty-acid pitch; animal and vegetable oils or fats; and wool grease.

The tar and pitch compositions (Group No. 2) are used: (a) for manufacturing multiple-layered prepared roofings, and (b) for preparing single-layered tarred felt, used for constructing "built-up" roofings (p. 419) and waterproofing membranes (p. 428). The Group No. 2 compositions (except fatty-acid pitch) are not recommended for manufacturing single-layered prepared roofings due to the fact that they are insufficiently weather-resisting. On the other hand, the Group No. 1 compositions on account of their greater weather-resistance may be used indiscriminately for manufacturing single or multiple layered prepared roofings, also for asphalt-saturated felt used for constructing "built-up" roofs and waterproofing membranes.

The characteristics of the tar and pitch compositions correspond with the figures given for soft coal-tar pitch (see p. 251). Saturating mixtures prepared from asphaltic products should comply with the following characteristics:

(1) The viscosity at the saturating temperature should be as low as possible to accelerate the speed of absorption by the fabric.

(2) The penetration at 77° F. should be greater than 60 (Test 9b), and consistency (Test 9c) less than 15, otherwise the saturated fabric will be brittle.

(3) The susceptibility factor should be as low as possible, and preferably less than 30.

(4) The saturant should be ductile.

(5) Its fusing-point by the B. and R. method (Test 15b) should range from 95 to 160° F., and preferably between 110 and 150° F.

(6) It should contain the smallest possible percentage of volatile matter, and preferably less than 3 per cent at 500° F. in four hours (Test 16a).

(7) It should have a flash-point well above the temperature at which it is raised during the process of fluxing or while saturating the fabric (at least 50° F.), and preferably above 475° F. (Test 17a).

(8) It should contain the largest possible percentage soluble in carbon disulphide, and preferably exceeding 97 per cent.

(9) It should contain a comparatively large percentage soluble in 88° naphtha, and preferably exceeding 85 per cent.

(10) It should be weatherproof (see p. 574).

Substances formerly used for saturating purposes included rosin and dead oil,¹ pine tar,² etc., but these are deficient in weather-resisting properties.

At the present time the materials most commonly employed for saturation purposes include soft coal-tar pitch, residual oil, soft residual asphalt and soft blown petroleum asphalt, of which the respective merits from a weather-resisting point of view, have been considered in Chapter XXIII.

Fire-resisting saturants have recently been suggested, composed of chlorinated bituminous bodies, including naphthalene, wax tailings, dead-oil, coal-tar, etc.³ These are used for saturating a single sheet of felted or woven fabric.⁴

Bituminous Coating and Adhesive Compositions. These may be used for surfacing the saturated fabrics (single or multiple layered) and also for cementing together two or more layers of fabric (all of which may be bituminized, or some bituminized and some untreated) in manufacturing multiple layered sheets. The coating and adhesive compositions include the same groups of substances used for the saturant (p. 391), but prepared of a harder consistency and usually also of a higher fusing-point. The bituminous materials first used for these purposes included the fatty-acid pitches,⁵ native asphalts, sludge asphalts,⁶ residual asphalts, etc.

The prime requisite of the bituminous coating composition is that it should possess maximum weather-resisting properties, since the longevity of the prepared roofing depends largely upon the unalterability and integrity of the coating. The principles to be followed in making this mixture have already been discussed (see p. 338).

Bituminous coating and cementing compounds should preferably comply with the following characteristics:

(1) The appearance of the surface on aging (Test 3) should be bright, and especially where the bituminous coating is to be surfaced with talc or other white mineral dusting finish (p. 394).

(2) The hardness at 77° F. should fall between 10 and 50 on the penetrometer (Test 9b), and between 15 and 30 on the consistometer (Test 9c).

¹ U. S. Pat. 205,135 of June 18, 1878 to W. H. Rankin.

² U. S. Pat. 398,337 of Feb. 19, 1889 to W. B. Lupton.

³ U. S. Pat. 914,223 of Mar. 2, 1909 to J. W. Aylsworth; 914,251 to Carleton Ellis and Karl P. McElroy; 1,162,453 of Nov. 30, 1915 to S. R. Church.

⁴ U. S. Pat. 914,222 of Mar. 2, 1909 to J. W. Aylsworth; 914,300 of Mar. 2, 1909 to Karl P. McElroy.

⁵ U. S. Pat. 128,599 of Jul. 2, 1872 to W. B. Davies; 423,042 of Mar. 11, 1890 to A. N. Ford; English Pat. of 1867, Sept. 21, No. 2,656 to G. E. Marchisio; 1868, Apr. 23, No. 1,336 to Joseph Rogers; 1872, Aug. 29, No. 2,572 to W. R. Lake; 1874, Feb. 4, No. 447 and No. 449 to John Macintosh; 1876, Mar. 27, No. 1,309 to Caleb Tayler.

⁶ Eng. Pat. of 1,888, Apr. 14, No. 5,577 to W. P. Thompson.

(3) The susceptibility factor should be as low as possible, and in the case of asphaltic compounds preferably less than 35.

(4) The ductility should preferably be greater than 1 at 77° F. (Test 10b).

(5) The tensile strength should preferably be greater than 0.5 at 77° F. (Test 11).

(6) The fusing-point should be such that the composition will not be affected by the highest sun temperature to which it may be subjected. It should not be lower than 160° F., nor higher than 260° F. by the ball and ring method (Test 15b), the upper limit applying to products having a low susceptibility factor, including blown petroleum asphalts, fluxed asphaltites, etc.; and the lower limit to coatings surfaced with fine sand or coarsely ground talc. The corresponding range by the K. and S. method (Test 15a) shall be between 145 and 240° F.

(7) The volatile matter should preferably be less than 2 per cent at 500° F. in four hours (Test 16a).

(8) The flash-point should preferably be above 500° F. (Test 17a).

(9) The solubility in carbon disulphide should preferably not be less than 98 per cent, although this is subject to modification where mineral ingredients are purposely added for the reasons which follow.

(10) The larger the percentage of fatty substances (saponifiable) present in the mixture, the better will be its weather-resisting properties, other things being equal.

It is sometimes customary to mix mechanically a certain proportion of very finely powdered mineral matter with the surface coating while in a molten condition, and before it is applied to the surface of the roofing, for one or more of the following reasons:

(1) To increase the weather-resistance of the bituminous mixture. Opaque pigments have been used for this purpose, including graphite,¹ lampblack,² etc. These serve to exclude the actinic rays of the light, which contribute largely to the decomposition of bituminous substances (p. 576).

(2) To impart a color to the bituminous coating. For this purpose, bright mineral pigments of various colors are mixed throughout a coating consisting of special bituminous compositions having a brown streak (Test 6) or as an alternative showing a transparent to translucent brownish color when viewed on glass in a thin layer.³ Bituminous compositions having a black streak, or otherwise appearing opaque when viewed on glass in a thin layer, will not answer, for although they may initially show the color of the pigment, nevertheless this will disappear after a time turning a dull black, since black bituminous mixtures weather to intensely black substances, due doubtless to the liberation of free carbon by the actinic light rays.

(3) To serve as an extender and reduce the cost of the finished product. Many substances have been used for this purpose, including finely ground limestone, shale, fullers' earth, clay,⁴ infusorial earth,⁵ silica, etc. Another plan consists in applying part of the bituminous coating, then the mineral matter such as flake mica,

¹ U. S. Pats. 686,191 of Nov. 5, 1901 to W. H. Bache; 853,117 of May 7, 1907 to Clifford Richardson and C. N. Forrest; German Pat. Appl. 13,156 of Nov. 17, 1904 to Hans Christen; Ger. Pat. Appl. A-6,371 of 1907 to E. Kutznitzki.

² U. S. Pat. 727,507 of May 5, 1903 to F. J. Warren.

³ U. S. Pats. 775,635 and 775,636 of Nov. 22, 1904 to L. C. Rugen and Herbert Abraham; Eng. Pat. of 1913, Jun. 18, No. 14,063 to Georg Halle.

⁴ Eng. Pat. of 1881, Jun. 27, No. 2,815 to A. M. Clark.

⁵ U. S. Pats. 416,791 of Dec. 10, 1889 to J. I. Livingston and William Griscom; 437,033 of Sep. 23, 1890 to R. S. Merrell.

and finally the balance of the bituminous coating, thus obtaining an intermediate layer of mineral matter.¹

Where the roofing is to be constructed of more than one sheet of fabric, very fine mineral matter may be mechanically mixed with the bituminous adhesive layers for reasons 1 and 3.

Surfacings of Mineral Matter. Three types of mineral matter are distinguished for this purpose, viz.: very fine mineral dust, moderately coarse mineral granules and coarse mineral particles.

The very fine mineral dust is sifted on the surface of the roofing usually while still hot, for the purpose of preventing the convolutions of the roll from sticking together after it is wound up, or otherwise packed for shipment. A certain proportion of it embeds itself in the surface coating, but most remains detached, so that it will either shake out of the roll, or wash off the roof when applied to the building. The very fine dusting finish is therefore applied from a utilitarian standpoint rather than for decorative effects. Finely ground talc, silica, mica, limestone, infusorial earth, etc., are used for this purpose.

Moderately coarse mineral granules are purposely *embedded* in either the top or bottom coating, or both, for decorative effects. The mineral matter should be practically free from fines, and consist of uniformly sized granules, preferably angular. The following materials have been used, viz.: sand, coarsely ground talc, coarse flakes of mica,² also *colored* mineral particles including red or green crushed slate,³ crushed rock of various colors,⁴ artificially colored sand,⁵ colored grit,⁶ baked preformed earthy particles of various colors,⁷ crushed brick, tile, or marble, particles of sand or grit prepared with an oil paint baked on superficially, etc.⁸

Coarse mineral particles, either uncolored or colored, are similarly embedded in the surface coating for decorative effects, including small pebbles, gravel, crushed feldspar or granite,⁹ crushed seashells,¹⁰ granulated slag,¹¹ etc.

Surfacings of Vegetable Matter. The materials in this group include

¹ U. S. Pat. 1,187,259 of Jun. 13, 1916 to B. G. Casler.

² U. S. Pat. 109,486 of Nov. 22, 1870 to Frederick Beck.

³ U. S. Pat. 310,192 of Jan. 6, 1885 to J. T. Edson; 1,007,146 of Oct. 31, 1911 to E. J. Schroder.

⁴ Ger. Pat. Appl. 10,800 of Mar. 14, 1904 to A. W. Andernach.

⁵ U. S. Pat. 1,233,501 of July 17, 1917 to J. C. Pelton.

⁶ U. S. Pat. 1,022,764 of Apr. 9, 1912 to S. G. Wright.

⁷ U. S. Pat. 1,190,505 of July 11, 1916 to H. E. Boardman; Eng. Pat. of 1912, Apr. 1, No. 7,872 to A. J. Boulton.

⁸ U. S. Pat. 1,248,179 of Nov. 27, 1917 to E. J. Schroder.

⁹ U. S. Pat. 130,376 of Aug. 13, 1872 to Howard Kirk and James Winsmore, Jr.

¹⁰ U. S. Pat. 753,982 of Mar. 8, 1904 to S. R. Holland; 1,235,270 of July 31, 1917 to J. B. Wise.

¹¹ U. S. Pat. 453,979 of June 9, 1891 to G. S. Lee.

wood flour or sawdust,¹ granulated cork,² etc. These are embedded in the surface coating while it is hot. The wood flour prevents the convolutions of the rolls from sticking together, and at the same time promotes the adhesion between the fabrics and the hot cementing compound in constructing built-up roofs or waterproofing membranes. Cork is used primarily for insulative effects in cold storage work. Bituminized fabrics surfaced with cork cannot be used for roofing purposes on account of the combustible nature of the cork surfacing.

Saturating the Fabric. Felted or woven fabrics are impregnated with the bituminous saturating mixture by continuously running the web through a tank of the latter maintained at a high temperature.

Attempts have been made, but without success, to saturate the felt fibres when they are originally formed into the sheet.³ Experiments have recently been made with an alternative method of intermingling the fibrous and bituminous constituents in the presence of water, by forcing them through a perforated steel plate, and then moulding the product in sheet form.⁴

At the present time the trade recognizes two types of saturated fabric, viz.:

- (1) Those saturated with tar products.⁵
- (2) Fabrics saturated with asphaltic products,⁶ including fatty acid pitch.⁷

A modern form of apparatus for producing tar-saturated fabrics is illustrated in Fig. 120. The roll of unsaturated fabric is mounted at the left of the illustration. The frame or "gallows" in the centre lowers the web into a steam-heated tank carrying the hot tar (not shown) by the means of the crank illustrated in the foreground. After leaving the bath, the saturated sheet passes around two steam-heated rolls (shown at the right of the frame work), and thence around the winding mechanism shown at the extreme right of the illustration.

A machine for saturating fabrics with asphalt is shown in Fig. 121. The roll of unsaturated fabric is supported at the rear of the illustration, whence it is lowered into the tank of the melted asphalt (not shown), by the vertical frame operated by the crank shown at the left. After leaving the tank, the saturated sheet passes between two steam heated press-rolls one above the other, located in front of the frame, and then around five steam-heated rolls mounted in two tiers, three on top and two below. These drive the excess of asphalt into the sheet, causing the

¹ U. S. Pat. 1,203,403 on Oct. 31, 1913 to Mathias Poulson.

² U. S. Pat. 674,219 of May 14, 1901 to J. A. Scharwath.

³ U. S. Pat. 103,199 of May 17, 1870 to Samuel Kingan; Ger. Pat. 216,753 of Sep. 6, 1906 to Julius Kathe.

⁴ U. S. Pat. 1,204,632 of Nov. 14, 1916 to J. C. Woodley and R. P. Perry.

⁵ U. S. Pats. 103,536 of May 31, 1870 to T. R. Abbott; 111,611 of Feb. 7, 1871 to J. M. Cobb; 119,059 of Sept. 18, 1871 to H. N. Stinson; 230,148 of July 20, 1880 to G. S. Page; 825,744 of July 10, 1846 to A. E. Millington.

⁶ British Pat. of 1876, May 21, No. 2,295, to J. S. Norrie; U. S. Pats. 820,694 of May 15, 1906, to L. A. Bond; 876,008 and 876,010 of Jan. 7, 1908 to F. C. Overbury.

⁷ Ger. Pat. 122,893, May 5, 1899, to A. W. Andernach.

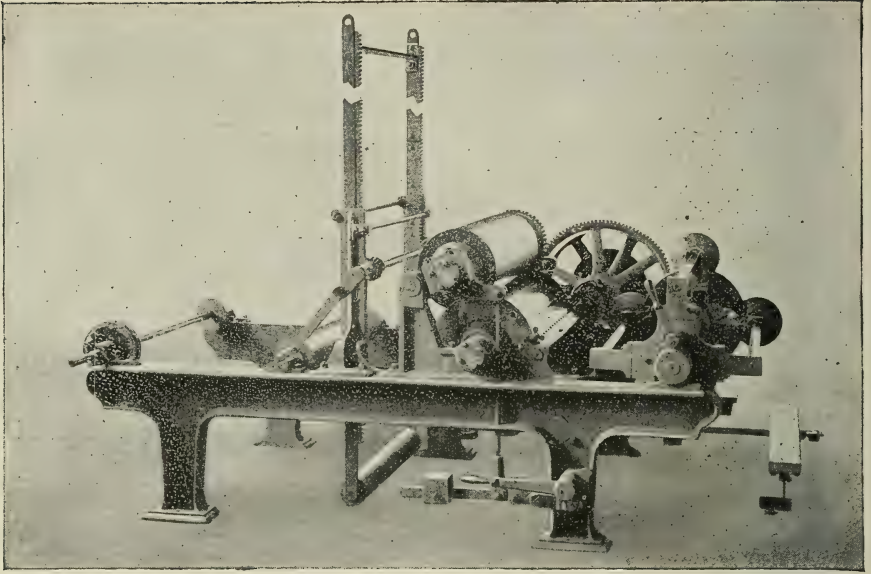

Courtesy of The Moore & White Co.

FIG. 120.—Tar Saturator.

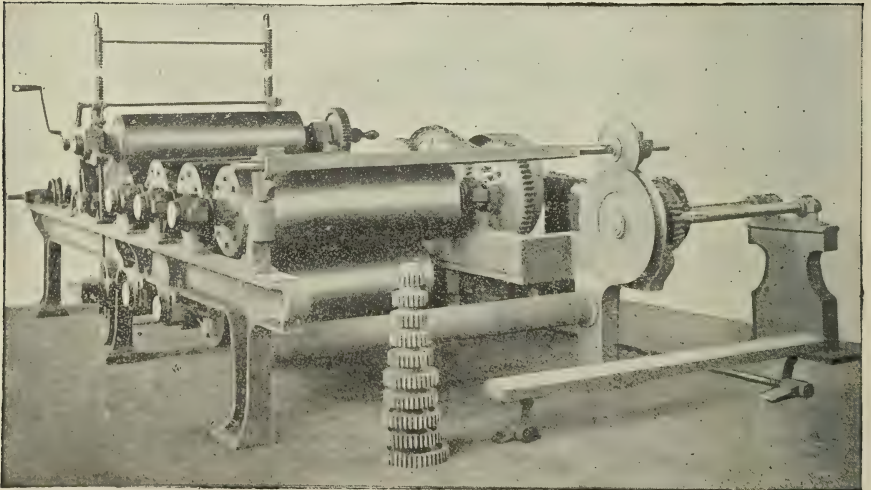

Courtesy of The Moore & White Co.

FIG. 121.—Asphalt Saturator.

saturated fabric to leave the machine perfectly "dry." It is then wound in large rolls on the automatic winder shown in the foreground.

The tanks in both the tar and asphalt saturators may be heated either by steam or direct fire. The former is ordinarily used because of the safety and ease of control. Tar products are usually maintained at 200–270° F., and asphaltic products at 225–400° F. In the types of machines illustrated, the fabric may be saturated at a speed of 330–350 lineal feet per minute. The weight of saturation absorbed by the fabric is controlled by the depth to which the web is immersed in the tar or asphalt, which in turn is regulated by raising or lowering the frame. The surface of the web in contact with the saturant varies from 10 to 30 lineal feet.

The following figures will give some idea of the percentages of saturating materials taken up by the fabric, based on its raw weight:

Felt will absorb 115–180 per cent of soft coal-tar pitch, or 100–165 per cent by weight of asphalt.

Burlap will absorb 90–125 per cent of soft coal-tar pitch, or 75–100 per cent by weight of asphalt.

The larger the percentage of any given saturant absorbed by the felted or woven fabric, consistent with the formation of a "dry" surface, the more durably will the fibres be water-proofed and weather-proofed. If the felt is undersaturated, the finished sheet will be porous and absorb moisture in service. On the other hand, if the sheet is oversaturated, a part of the saturant will remain on the surface and cause the convolutions of the roll to stick together. The best practice consists in running a sheet so that it will show "wet spots" as it leaves the bath of saturant, which, however, will become absorbed when it cools to atmospheric temperature. The absorption may be assisted by preventing the surface cooling too quickly, so that the natural contraction of the saturant will have an opportunity of drawing in the "wet" spots by capillarity.

It is customary to market tar and asphalt saturated felts in rolls of the following dimensions and weights:

Size of Roll.	Weight per 100 Sq.ft.	Weight per 108 Sq.ft.
<i>" Slaters' Felt " (Tarred):</i>		
30 lb. per 500 sq.ft.....	Pounds. 6.0	Pounds. 6.5
33 lb. per 500 sq.ft.....	6.6	7.1
40 lb. per 500 sq.ft.....	8.0	8.65
<i>Tarred felt:</i>		
50 lb. per 432 sq.ft.....	11.5	12.5
60 lb. per 500 sq.ft.....	12.0	13.0
40 lb. per 324 sq.ft.....	12.3	13.3
55 lb. per 432 sq.ft.....	12.75	13.75
60 lb. per 432 sq.ft.....	14.0	15.0
48½ lb. per 324 sq.ft.....	15.0	16.2
60 lb. per 400 sq.ft.....	15.0	16.2
43 lb. per 216 sq.ft.....	20.0	21.4
60 lb. per 250 sq.ft.....	24.0	25.9
<i>Asphalt felt:</i>		
44 lb. per 432 sq.ft.....	10.2	11.0
60 lb. per 500 sq.ft.....	12.0	13.0
56 lb. per 400 sq.ft.....	14.0	15.0
48½ lb. per 324 sq.ft.....	15.0	16.2
43 lb. per 216 sq.ft.....	20.0	21.4

Fabrics saturated with tar or asphaltic products are used for the following purposes:

(1) As an intermediate product in the manufacture of "prepared roofings" and composition shingles.

(2) In the manufacture of bituminized floor coverings.

(3) For constructing "built-up" roofs.

(4) For constructing waterproofing membranes.

(5) For bituminous expansion joints.

"Prepared roofings" are distinguished from "saturated fabrics" by being composed of: (1) Single-layered fabrics coated alone, or both saturated and coated with bituminous compositions; (2) laminated (multiple layered) bituminated fabrics having at least one of the layers saturated, the fabric being either unsurfaced, or surfaced on one side, or else surfaced on both sides with bituminous compositions. In the next succeeding section, we will consider prepared roofings composed of a single layer of fabric.

Single-layered Prepared Roofings. In the early days of the industry it was customary merely to surface a felted or woven fabric with bituminous substances.¹ The next step in the development of the industry consisted in both saturating and coating a single web of fabric with bituminous mixtures, and surfacing with talc, sand, powdered limestone or gravel.²

Most of the prepared roofings manufactured to-day are made up of a single layer of "roofing felt" saturated with bituminous ingredients of relatively soft consistency, and surfaced on both sides with

¹ U. S. Pats. 3,598 of May 25, 1844, to Edouard Deutsch, describing the use of asphalt combined with fats or oils for coating paper or cloth; 17,851 of July 21, 1857 to J. B. Wards, describing cotton cloth coated with coal tar and fatty-acid pitch and surfaced with sand; 80,207 of July 21, 1868 to Alfred Paraf, coating woven cloth with a mixture of grahamite and vegetable oil; 151,683 of June 9, 1874 to Elias Burnham, coating felt with coal-tar pitch and sanding the surface; 187,748 of Feb. 27, 1877 to J. C. Cheatham, coating cloth with a mixture of coal tar, lime and sulphur and surfacing with gravel; 278,481 of May 29, 1883, to S. M. Allen, coating felt or paper with a mixture of asphalt and pulped fibres; Eng. Pat. of 1885, Oct. 31, No. 13,140 to J. E. A. Pierret, coating felt or burlap with a mixture of sludge asphalt, native asphalt, rosin and earthy matter and surfacing with sand; 1888, Mar. 5, No. 3,354 to Thomas Thomson, coating cloth with a mixture of fatty-acid pitch, vegetable oil, chalk, fibrous matter and a colored pigment; 1889, May 27, No. 8,795 to A. N. Ford, coating woven fabrics with a mixture of fatty-acid pitch, linseed oil, soap and petroleum.

² U. S. Pats. 93,859 of Aug. 17, 1869 to J. M. Cobb, felt saturated and coated with tar and surfaced with sand or gravel; 179,828, 179,829, and 179,830 of July 11, 1876 to C. M. Warren, also 180,081 of July 18, 1876, and 191,208 of May 22, 1877 to C. M. Warren, felt or paper saturated and coated with mixtures of native asphalt, residual asphalt and fatty-acid pitch; 282,139 of July 31, 1883 to Welcome White, felt saturated with tar and coated on one side with a mixture of coal tar, asbestos and soapstone; 300,946 of June 24, 1884 to Philip Carey, felt composed of wood pulp, asbestos and clay saturated and coated with asphalt; 345,399 of July 13, 1886 to C. M. Warren, felt saturated and coated with a mixture of native asphalt, sludge asphalt and fatty-acid pitch; 348,996 of Sept. 14, 1886 to T. J. Pearce, and W. M. Peardsley, saturating and coating a felted or woven fabric with residual asphalt; 358,502 of Mar. 1, 1887 to G. W. Swan, a woven fabric saturated and coated with residual asphalt and surfaced with limestone; Eng. Pat. of 1879, June 27, No. 2,596 to W. B. Ritchie, felt saturated and coated with a bituminous composition; 1897, Apr. 1, No. 8,343, to J. D. Blackwell, saturating and coating cloth with fatty-acid pitch; Ger. Pat. 92,308 of Aug. 12, 1895 to A. W. Andernach, felt saturated with coal tar, coated with a bituminous mixture containing sulphur, and surfaced with sand.

a harder bituminous composition. They are marketed in roll form, either 36 in. or 32 in. wide, measuring 108 sq.ft. in area, known commercially as a "square," which is sufficient to cover 100 sq.ft. of roof surface, allowing for 2-in. laps at the joints. Prepared roofings are marketed in several weights known to the trade as "plies." The term "ply," however, is a misnomer, as it does not, as one would suppose, refer to the layers of fabric forming the roofing, but is used to designate the *weight* of the sheet consisting of a *single* layer. It is customary to manufacture a so-called "1-ply" roofing to weigh 35 lb. gross per square, including the paper wrapper and heads, together with sufficient nails and liquid lap-cement for laying, packed in the core of the roll. The net weight of the roofing runs 2 to 4 lb. per square less than its gross weight. "2-ply" roofing weighs 45 lb. gross per square, and "3-ply" 55 lb. Heavier weights are also manufactured, especially in the case of roofings surfaced with moderately coarse to coarse mineral matter, which are often made to weigh 100 lb. per square or over. Unfortunately, no standard practice is followed in manufacturing the heavier weights, each manufacturer being guided by his own views.

The surface may be manufactured smooth, or it may have a "veined" appearance as illustrated in Fig. 122. In either event, it is customary to sprinkle a "dusting finish" of finely powdered mineral matter on the surfaces (p. 394) to prevent the convolutions of the roll sticking together during transit or in storage. It is desirable to apply the dusting finish while both coatings are hot, so that as much as possible will embed itself in the surfaces and will neither blow away nor be washed off the roofing by the first rainstorm, after being laid on a building. Not more than 3 lb. per square is necessary for this purpose.¹ In other cases, either one or both surface coatings may be adorned with moderately coarse particles of mineral matter (p. 400), including coarsely ground talc, of which 8 to 15 lb. are applied per square to both sides of the sheet (Fig. 123); small rounded grains of sand, of which 10 to 20 lb. per square are used, including both sides of the roofing (Fig. 124); and angular particles of crushed slate² or greenstone,

¹ Granularmetric analyses of the talc, used as "dusting finish" will show from 5 to 25 per cent of particles passing an 80-, but retained on a 100-mesh sieve, the former applying to finely ground talcs and the latter to coarsely bolted products.

² Crushed slate used by the leading manufacturers in this country tests as follows:

Passing 60 but retained on 80-mesh sieve.....	0-1%
Passing 40 but retained on 60-mesh sieve.....	1-10%
Passing 20 but retained on 40-mesh sieve.....	20-65%
Passing 10 but retained on 20-mesh sieve.....	35-70%
Passing 8 but retained on 10-mesh sieve.....	0-1%

Specifications require that less than 2 per cent shall pass a 40- or an 8-mesh sieve, less than 33 per cent shall pass a 20-, and more than 50 per cent pass a 10-mesh sieve.



FIG. 122.—Prepared Roofing Finished in a Veined Surface.



FIG. 123.—Prepared Roofing Finished with Coarse Talc.

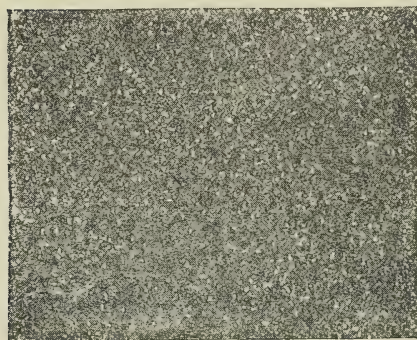

FIG. 124.—Prepared Roofing Finished with Fine Sand.

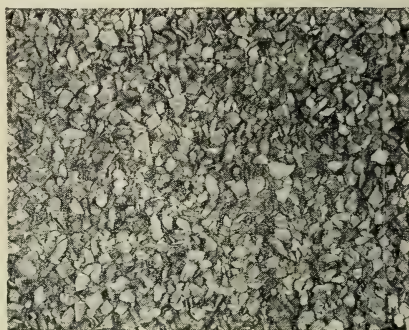

FIG. 125.—Prepared Roofing Finished with Crushed Slate.



FIG. 126.—Prepared Roofing Finished with Crushed Feldspar.

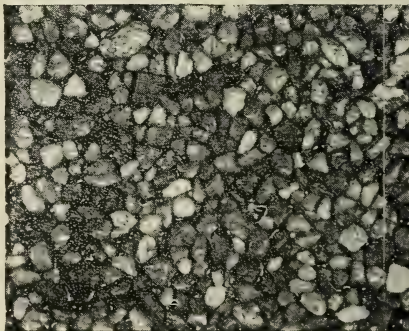

FIG. 127.—Prepared Roofing Finished with Pebbles.

of a reddish or greenish color respectively (Fig. 125), of which 25 to 35 lb. per square are affixed to one side of the sheet. It is customary to embed the coarsely ground talc in both coatings, the rounded grains of sand in either one or both coatings, and the angular particles of slate or greenstone in one coating only. The last, known as "slate-surfaced roofing," is usually manufactured from a No. 50 to No. 55 dry felt, so that the finished weight including nails and cement will range between 80 and 85 lb. per square.

One-ply roofing is variously manufactured from No. 30 to No. 45 dry felt, two-ply from No. 40 to No. 60 and three-ply from No. 50 to No. 75. Where the light weight dry felt is used in manufacturing any particular ply, a corresponding larger proportion of coating must be applied to bring the weight of the finished roofing to 35, 45 or 55 lb. gross, whichever the case may be. The weight of dry felt used will average No. 35, No. 50 and No. 65 for the one-, two- and three-ply respectively.

In other cases coarse particles of mineral matter are embedded in the upper surface only, including crushed feldspar, of which 30-40 lb. are used per square (Fig. 126), or even fairly large pebbles, of which 40-65 lb. are used per square (Fig. 127).

The weights of bituminous coating (unfilled or filled) applied per square, exclusive of the mineral surfacing, range as follows:

1-ply (35 lb.).....	6 to 15 lb. (both sides)
2-ply (45 lb.).....	7 to 20 lb. (both sides)
3-ply (55 lb.).....	8 to 25 lb. (both sides)
Slate surfaced (80 lb.).....	15 to 25 lb. (one side)

The thicknesses of the finished roofings vary between the following limits:

Surfaced with talc.....	1-ply (35 lb.)	50 to 60 mils
Surfaced with talc.....	2-ply (45 lb.)	65 to 80 mils
Surfaced with talc.....	3-ply (55 lb.)	80 to 100 mils
Surfaced with fine sand.....	1-ply (35 lb.)	45 to 50 mils
Surfaced with fine sand.....	2-ply (45 lb.)	60 to 65 mils
Surfaced with fine sand.....	3-ply (55 lb.)	75 to 80 mils
Surfaced with fine sand.....	X-ply (65 lb.)	90 to 100 mils
Surfaced with fine sand.....	XX-ply (75 lb.)	105 to 115 mils
Surfaced with crushed slate.....	(80 lb.)	120 to 145 mils

The composition of typical single-layered prepared roofings is shown in Table XXXII.

Cross-sections of the principal forms of single-layered prepared roofing are shown in A, B, and C, Fig. 199.

A single sheet of woven fabric such as duck, surfaced on one side with a bituminous mixture dusted with powdered talc or mica, is largely used at the present time for covering steamboat decks or porch roofs where subjected to foot traffic. The material is laid with the bituminous side down, whereupon the unsurfaced duck is painted with several coats of a colored linseed-oil-pigment paint. A single sheet of woven fabric saturated with a soft bituminous composition, coated on both sides

Roofing 36 Inches Wide.	TYPE A.						TYPE A.					
	Smooth Surfaced (Unfilled Coatings).						Smooth Surfaced (Filled Coatings).					
	1-ply.		2-ply.		3-ply.		1-ply.		2-ply.		3-ply.	
	Lb.	%	Lb.	%	Lb.	%	Lb.	%	Lb.	%	Lb.	%
<i>Mineral Matter</i>												
Fine dusting finish detached (top and bottom).....	1.5	4.7	1.8	4.3	2.1	4.0	1.5	4.7	1.8	4.3	2.1	4.0
Fine dusting finish embedded in top coating.....	0.3	1.0	0.4	1.0	0.5	1.0	0.3	1.0	0.4	1.0	0.5	1.0
Fine dusting finish embedded in bottom coating.....	0.2	0.6	0.3	0.7	0.4	0.8	0.2	0.6	0.3	0.7	0.4	0.8
Sand embedded in top coating.....												
Sand embedded in bottom coating.....												
Crushed slate embedded in top coating.....												
Filler admixed with top coating.....							3.6	11.2	4.1	9.7	5.0	9.6
Filler admixed with bottom coating.....							2.5	7.8	2.8	6.7	3.3	6.3
Filler admixed with cementing layer.....												
<i>Bituminous Matter</i>												
Present in top coating.....	4.7	14.7	5.1	12.1	5.5	10.6	5.4	16.9	6.2	14.8	7.4	14.2
Present in bottom coating.....	3.1	9.7	3.4	8.1	3.6	6.9	3.6	11.2	4.2	10.0	4.9	9.5
Present in cementing layer.....												
Saturating the felt.....	12.1	37.8	17.5	41.7	23.3	44.8	8.1	25.3	12.1	28.8	16.0	30.8
<i>Fibrous Matter</i>												
One or more layers dry felt.....	10.1	31.5	13.5	32.1	16.6	31.9	6.8	21.3	10.1	24.0	12.4	23.8
Dry Burlap.....												
Total per square (108 sq.ft.).....	32	100	42	100	52	100	32	100	42	100	52	100
<i>Fixtures</i>												
Nails, including cardboard container.....	1.6		1.6		1.6		1.6		1.6		1.6	
Can of lap cement (1-pint).....	1.4		1.4		1.4		1.4		1.4		1.4	
Total per square (108 sq.ft.).....	35		45		55		35		45		55	

with a mixture of harder consistency and surfaced with powdered talc or mica, is being used largely for roofing railroad passenger cars and locomotive cabs. This is manufactured from "numbered" ducks weighing 11.46 and 14.73 ounces per square yard, the finished weights being 2.15 and 2.30 lb. per square yard respectively.

In manufacturing single-layered prepared roofings, the sheet of felted or woven fabric is first saturated by passing it through a bath of the melted bituminous saturation. The saturated sheet may then be coated immediately with a bituminous composition and while it is still hot, or else it may be wound into large rolls, allowed to cool and coated later. Both methods are used at present, the latter

XXXII

TYPE B.						TYPE C.						TYPE C.		TYPE D.		TYPE E.		TYPE F.	
Sanded Top and Bottom.						Sanded Bottom Only.						Slate Surfaced.		Burlap Backed.		Double Layered.		Burlap Centre.	
1-ply.		2-ply.		3-ply.		1-ply.		2-ply.		3-ply.		
Lb.	%	Lb.	%	Lb.	%	Lb.	%	Lb.	%	Lb.	%	Lb.	%	Lb.	%	Lb.	%	Lb.	%
...	0.7	2.2	0.9	2.1	1.1	2.1	1.8	4.3	1.6	3.1
...	0.3	0.9	0.4	1.0	0.5	0.95	0.4	1.0	0.4	0.8
...	0.3	0.7	0.4	0.8
5.0	15.6	6.0	14.3	7.5	14.45	7.5	10.4
5.0	15.6	6.0	14.3	7.5	14.45	5.0	15.6	6.0	14.3	7.5	14.45	7.5	10.4
...	28.0	36.3
...	2.0	6.3	2.3	5.5	2.6	5.0	8.3	10.8	2.3	5.5	2.1	4.0
...	1.7	5.3	1.9	4.5	2.2	4.2	4.3	10.2	2.1	4.0
...	2.4	4.6
4.2	13.1	4.7	11.2	5.1	9.8	4.0	12.5	4.5	10.7	5.2	10.0	12.3	16.0	4.2	10.0	4.2	8.1	5.8	8.1
2.9	9.1	3.1	7.4	3.5	6.7	3.4	10.6	3.8	9.1	4.5	8.7	8.7	20.7	4.2	8.1	5.8	8.1
...	4.8	9.3	10.5	14.5
8.1	25.3	12.1	28.8	16.0	30.8	8.1	25.3	12.1	28.8	16.0	30.8	16.0	20.8	8.1	19.3	8.1	15.5	8.1	11.2
...	8.1	15.5	8.1	11.2
6.8	21.3	10.1	24.0	12.4	23.8	6.8	21.3	10.1	24.0	12.4	23.8	12.4	16.1	6.8	16.2	6.8	13.1	6.8	9.5
...	5.1	12.1	5.1	7.1
32	100	42	100	52	100	32	100	42	100	52	100	77	100	42	100	52	100	72	100
1.6	...	1.6	...	1.6	...	1.6	...	1.6	...	1.6	...	1.6	...	1.6	...	1.6	...	1.6	...
1.4	...	1.4	...	1.4	...	1.4	...	1.4	...	1.4	...	1.4	...	1.4	...	1.4	...	1.4	...
35	...	45	...	55	...	35	...	45	...	55	...	80	...	45	...	55	...	75	...

being known as the intermittent and the former as the continuous process. Each is claimed to have its particular advantages. The author is inclined to favor the continuous process, since the coating is applied directly to the hot sheet, which enables the saturating compound on cooling and contracting to draw the hot and plastic surface coating into the sheet, forming a "key" between the coating and the fabric, and producing a denser sheet of roofing. For this reason, roofings made by the continuous process do not measure as thick for a given weight, although to counterbalance this, they are less porous, and consequently are less apt to absorb moisture.

The intermittent type of roofing machine is constructed in two units, operating independently. The felt is first saturated and wound into large rolls on an asphalt saturator as illustrated in Fig. 121, and subsequently run through the coating machine shown in Fig. 128. The roll of saturated felt, 1, is passed through steam-heated coating rolls 2 and 3, which distribute the melted coating composition fed from an overhead storage tank (not shown). Mineral surfacings may be applied by the mechanically actuated hopper 4. The sheet is then drawn through the "pull-rolls" 5, after which it is cooled by an automatic looping device, which catches the sheet at 6 and carries it along towards the winder and cutter 8, allowing the loops to accumulate at 7. The cooling loops 7 will accommodate 25-50 squares of roofing and thus enable the coating operation to continue uninterruptedly, even though the winder and cutter may temporarily cease operating, as for example, when a finished roll of roofing is removed from the winder bar at 8.

The simplest form of machine for manufacturing roofing continuously is illustrated in Fig. 129. A roll of raw felt is shown on the "unwinder" at the left of the figure. The sheet then passes through the saturator, zigzagging back and forth several times to present a large area to the compound and increase the time of contact. From the saturator the web passes around the steam-heated "saturating rolls" which "drive in" the saturant and remove the excess, so that the surface of the sheet will appear "dry," when the top and bottom coatings are applied by the steam-heated coating rolls. The melted coating mixture is flowed on the upper side of the sheet where it is spread uniformly by the upper roll and the excess allowed to flow into a small tank underneath, where it is picked up by the lower coating roll and spread on the under side of the sheet. The mineral surfacing is applied when the sheet reaches the coolers by the contrivance shown in Fig. 130, the sheet first passing underneath hopper *A* where particles of talc, sand or moderately fine granular matter are evenly distributed on the upper surface, and then around the water-cooled roll *A* which firmly presses the mineral matter into the hot and soft coating. Hopper *B* applies the particles to the underside of the sheet, and the water-cooled roll *B*, embeds them into the bottom coating. The "coolers" consist of large hollow water-cooled drums. The "pull" rolls supply the necessary tension and are provided with a measuring device, which enables the winder shown at the right of the figure to roll up and cut the finished roofing into small units of suitable lengths. The details of the winding mechanism are depicted in Fig. 131.

Another machine for manufacturing roofing continuously, embodying some of the features of both machines previously described, is shown in Fig. 132. The sheet travels from right to left, first through a "saturator," consisting of a deep tank heated by steam or direct fire, and then around a stationary air-cooled looping system. The surface coatings are next applied to both sides of the sheet, and while still hot, mineral particles are sifted on the upper surface from the so-called "slate feeder." The sheet then travels around eight water-cooled drums, of which the first two serve as press-rolls to firmly embed the particles in the coating. After this, the web is carried along by a movable looping device similar to that shown in Fig. 128, which serves to cool and store the finished sheet until it can be handled by the draw-rolls, winder and cutter shown at the extreme right of the illustration. One method consists in saturating and coating a sheet of double width and then slitting it longitudinally into two sheets of the desired width.¹

¹ U. S. Pats. 876,008 and 876,010 of Jan. 7, 1908 to F. C. Overbury.

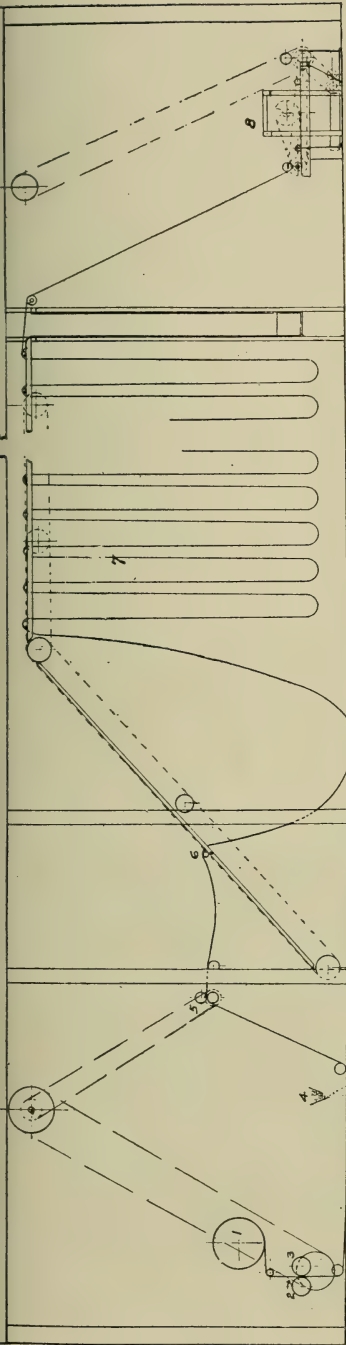

FIG. 128.—Coating Machine Used in the Intermittent Process of Manufacturing Roofing.

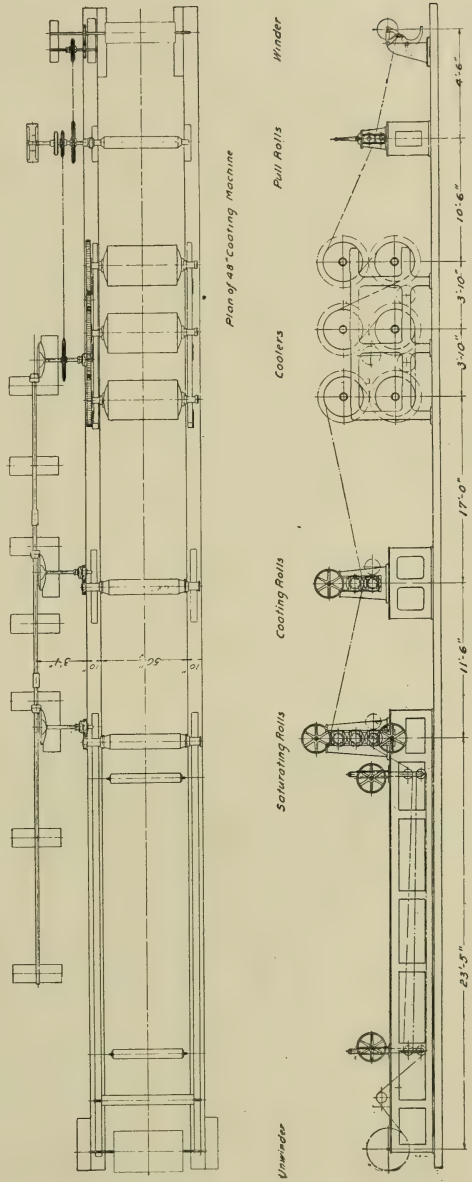
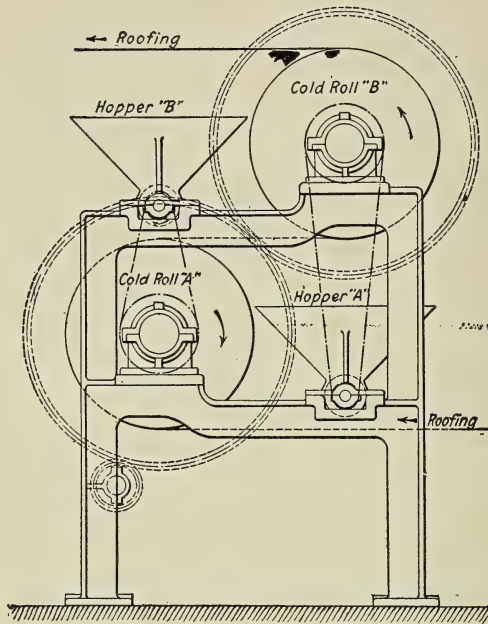

FIG. 129.—Continuously Operating Machine for Manufacturing Prepared Roofing. Courtesy of the Moore & White Co.



Courtesy of Guyton & Cumfer Mfg. Co.

FIG. 130.—Device for Applying Mineral Particles to the Surface of Prepared Roofing

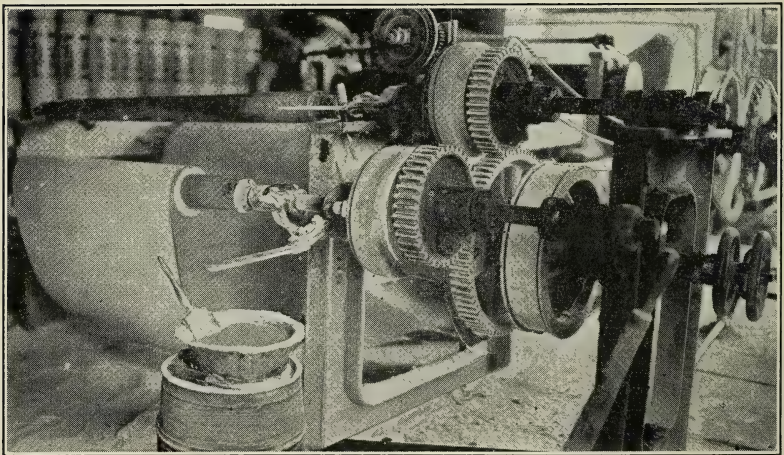

FIG. 131.—Winding Mechanism.

Very often prepared roofings surfaced with finely powdered mineral matter, such as talc or limestone, turn yellow on aging indoors. This discoloration is due to the use of:

(1) Bituminous coating or saturating mixtures containing a large proportion of volatile matter.

(2) Coating compositions which do not blend thoroughly.

(3) Coatings containing a large proportion of "greasy" or oily constituents which impart a dull surface to the specimen on aging indoors one week (Test 3).

This yellow discoloration not only detracts from the appearance of the roofing and interferes with its sale, but indicates that improper mixtures have been used in its manufacture.

The function of the coating is to seal in the saturation, protect it from oxidation and volatilization, and exclude moisture from the fabric fibres. The coating should weather away gradually and *uniformly*. As soon as the coating disappears through weathering or attrition of the elements, the fabric will commence to rot and weaken, until it tears during the first heavy wind, and this will terminate the life of the roofing.

A properly laid prepared roofing will no longer fulfil its function as a result of:

(1) Local perforations due to the coating compound failing in spots, the seams opening up on account of the lap-cement being faulty, hard lumps or particles in the felt, rusting away of the nails, the bituminous matter being extracted from the felt by rosin or turpentine in the roof boards, the fabric drying out or otherwise becoming brittle and cracking, the roof being subjected to undue external violence such as a hailstorm, rough walking upon it, dragging heavy articles over it, objects falling upon it, etc.

(2) The fabric weakening to such an extent that it is torn and rendered unserviceable by the first heavy windstorm. As long as the weather coating remains intact, this will not occur, but just as soon as it wears thin or disappears, moisture will find its way into the fabric and rot its fibres, so that the roof is soon doomed unless it is repainted (p. 470).

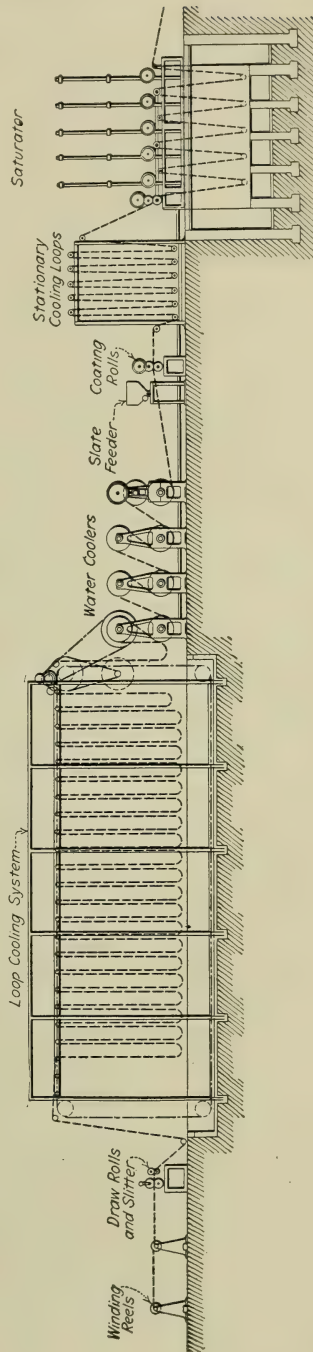

Courtesy of Guyton & Cumfer Mfg. Co.
 Fig. 132.—High-speed Continuously Operating Machine for Manufacturing Prepared Roofing.

(3) Trouble caused by the underlying roof boards, due to shrinkage, cracking, splitting or rotting, which would subject the roofing to excessive strains, and either rip it from the seams or tear the sheets.

Most manufacturers recommend that prepared roofings be coated from time to time with a bituminous paint (p. 470) to renew the weather-coating as it wears away. This procedure is applicable to smooth-surfaced roofings, or ones surfaced with very fine sand or grit. Slate-surfaced roofings or roofings coated with gravel or crushed rock are not amenable to painting, due to the interference of the coarse mineral particles. With proper care and repainting at intervals, a properly manufactured single layered 3-ply smooth surfaced prepared roofing will remain serviceable for 20 years. Some manufacturers guarantee the 1-ply roofing to last five years without painting, 2-ply from five to ten years with one painting, and the 3-ply from ten to twenty years with two or more paintings. As in other industries, it is generally true that the smaller and less responsible the manufacturer, the more extravagant the guarantee offered. In recent years, guarantees have been very much overdone by certain prepared roofing manufacturers, and as a result the public has grown wary, but is fortunately beginning to pay more attention to the manufacturer's reputation and to the record of the particular brand of roofing, which after all afford much better assurance than a "guarantee."

Laminated Prepared Roofings. These consist of two or more layers of bituminized *felted* fabric, composed of vegetable or animal fibres,¹ two or more layers of bituminized *woven* fabric composed of animal or vegetable fibres;² two or more layers of bituminized *felted* and *woven* fabric composed of animal or vegetable fibres;³ combinations of plain or saturated *asbestos* felt with bituminized woven or felted fabrics composed of vegetable and animal fibres.⁴

¹ U. S. Pats. 44,220 of Sept. 13, 1864, and reissue 4,862 of Apr. 9, 1872 to Alfred Robinson; 48,311 of Jun. 20, 1865, and 75,197 of Mar. 3, 1868 to Alfred Robinson; 202,902 of Apr. 23, 1878 to C. M. Warren; 211,669 of Jan. 28, 1879 to W. H. Rankin, 237,158 of Feb. 1, 1881 to R. A. Bendall; 256,368 of Apr. 11, 1882 to G. H. Pöschel; 278,278 of May 22, 1883 to Augustine Sackett; 291,600 of Jan. 8, 1884 to Josiah Jowitt; 312,451 of Feb. 17, 1885 to Michael Ehret, Jr.; 318,910 of May 26, 1885 to Josiah Jowitt; 341,043 of May 4, 1886 to Tobias New; 351,948 of Nov. 2, 1886 to C. M. Warren; 362,202 of May 3, 1887 to Philip Carey; 418,569 of Dec. 31, 1889 to H. W. Johns; 427,174 of May 6, 1890 to M. C. Kerbaugh; 429,885 of June 10, 1890 to W. H. H. Childs; 455,000 of June 30, 1891 to M. C. Kerbaugh; 674,219 of May 14, 1901 to J. A. Scharwath; 851,331 of Apr. 23, 1907 to H. R. Wardell; Eng. Pat. of 1873, Sept. 26, No. 3,147 to J. A. Turner; Ger. Pat. 121,436 of May 6, 1899 to A. W. Andernach.

² Eng. Pat. of 1888, Sep. 28, No. 13,971 to Donald Nicoll; U. S. Pat. 1,248,909 of Dec. 4, 1917 to H. B. Pullar.

³ U. S. Pats. 125,574 of Apr. 9, 1872 to H. W. Johns; 150,636 of May 5, 1874 to J. A. Turner; 278,722 of June 5, 1883 and 293,491 of Feb. 12, 1884, also 304,744 of Sept. 9, 1884 all to H. M. Miner; 385,057 of June 26, 1888 to Alexander Jones; 453,979 of June 9, 1891, and 460,668 of Jan. 31, 1893 both to G. S. Lee; 624,976 of May 16, 1899 to R. J. Redick; 636,022 of Oct. 31, 1899 to G. D. Crabbs and W. H. Pendery; 753,982 of Mar. 8, 1904 to S. R. Holland; 775,968 of Nov. 29, 1904 to August Gross; 813,336 of Feb. 20, 1896 to H. R. Wardell; 820,470 of May 15, 1906 to R. W. Bird; 845,414 of Feb. 26, 1907 to Samuel Herbert; Eng. Pat. of 1888, Apr. 14, No. 5,577 to W. P. Thompson; 1893, Oct. 14, No. 17,003 to Emile Pierret.

⁴ U. S. Pats. 333,138 of Dec. 29, 1885 to Francis Line; 418,519 of Dec. 31, 1889 to H. W. Johns; 690,526 of Jan. 7, 1902 to F. S. Miller and W. B. Davenport; 817,619 of Apr. 10, 1906 to G. F. Bishopric; 1,220,966 of Mar. 27, 1917 to O. R. Emigh; Ger. Pat. 141,760 of May 22, 1901 to Maurice Coutellier.

The fabrics may be combined in innumerable ways, and in as many layers as desired, but generally with five as the maximum. At the present time the most popular forms of multiple-layered prepared roofings include the following:

(1) Two or three layers of tarred felt cemented together with coal-tar pitch.

(2) Asphalt-saturated felt fastened with an asphaltic adhesive to an asphalt-saturated burlap, and surfaced top and bottom with an asphaltic composition.

(3) Burlap embedded in an asphaltic adhesive between two layers of asphalt-saturated felt, and surfaced top and bottom with an asphaltic composition.

(4) Untreated cotton duck fastened with an asphaltic adhesive to an asphalt-saturated and coated felt. This form is intended for use as a decking or porch covering, to have its upper surface painted with an oil paint, as previously described.

(5) Two or more layers of asphalt-saturated asbestos, fastened together with an asphaltic adhesive, and in some cases surfaced either with a sheet of unsaturated asbestos felt, or with an asphaltic coating composition.

(6) An asphalt-saturated fabric, either woven or felted, fastened with an asphaltic adhesive to a layer of asphalt saturated asbestos.

(7) Unsaturated asbestos fastened with an asphaltic adhesive to a layer of asphalt-saturated and coated felt.

Since a woven fabric (burlap or cotton ducking) absorbs a smaller percentage of bituminous saturation than a felted fabric, the former when saturated is far less weather-resisting. It is preferable, therefore, to use the woven sheet for *backing* a laminated roofing, and thus protect it from the direct action of the weather as much as possible, and where it will at the same time fulfil its function of adding to the strength of the finished product.

Processes have also been described involving the use of wire mesh fastened with an asphaltic adhesive to an asphalt-saturated felted or woven fabric composed of animal, vegetable or mineral fibres¹ but this is not practicable, as the cost of wire mesh is prohibitive, and besides is apt to rust out in a short time. Another structure consists of a sheet of thin lead embedded in an asphaltic adhesive between two layers of tarred felt.²

A more practical device consists in fastening a sheet of thin steel with an asphaltic adhesive between two layers of treated asbestos. This is marketed in either flat or corrugated sheets of 26 to 20 gauge, weighing 125 to 225 lb. per 100 sq. ft. net. The flat sheets measure 30 in. by 6 ft., 8 ft., 9 ft. or 10 ft. respectively,

¹ U. S. Pats. 446,775 of Feb. 17, 1891 to J. N. Hopper; 539,767 of May 21, 1895 to F. W. Coolbaugh and N. M. Goodlett; 767,723 of Aug. 16, 1904 to F. W. Terpenning.

² U. S. Pat. 441,036 of Nov. 18, 1890 to Arthur Siebel.

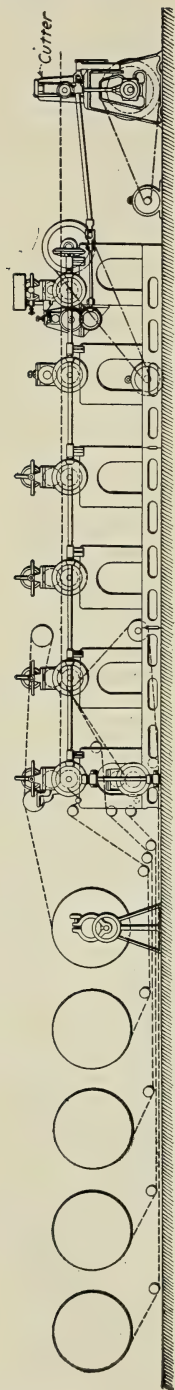

Courtesy of Guyton & Cumfer Mfg. Co.
 Fig. 133.—Machine for Assembling Multiple-layered Bituminized Fabrics.

and the corrugated sheets 20 in. by 6 ft., 8 ft., 9 ft. or 10 ft.¹ The asbestos surfacing is colored white, terra cotta, or dark gray, and waterproofed by impregnation with a vegetable drying oil to prevent its being affected injuriously by the weather. The material may either be used as a siding or roofing, and is strong, light, rust-proof and fire-resisting.

Flexible laminated prepared roofings may be manufactured either by the continuous or the intermittent process. If the former is used, the individual layers are first impregnated in a tar or asphalt saturator (p. 395), then wound in rolls of large diameter known as "jumbo" rolls, and finally joined in the desired number of layers and sequence on a form of machine illustrated in Fig. 133, designed to assemble not exceeding five layers. If made on a continuous-process machine, as many saturators must be provided as there are layers to be impregnated.

With the exception of 2- and 3-ply tarred roofings, multiple-layered roofings are not manufactured in standard weights. The 2-ply tarred roofing ranges between 40 and 45 lb., and the 3-ply between 60 and 68 lb. in one-square rolls.

Roll Roofings Finished with an Ornamental Surface. Numerous devices have been used to break the continuity of sheet roofing, by finishing it to simulate the appearance of tiles or shingles as illustrated in Fig. 134 (A, B, C, D and E). One method consists in embossing the sheet in imitation of tiles and filling in the depressions on the under side with a composition of matter,² another in decorating the surface by hexagonal, square or oblong impressions in imitation of shingles;³ coating portions of the surface with sand, gravel or other mineral matter and leaving adjacent portions uncoated in the form of shingles;⁴ printing the surface in hexagons,

¹ U. S. Pats. 788,358 of Apr. 25, 1905; reissue 12,475 of Apr. 24, 1906; and 816,661 of Apr. 3, 1906, all to F. D. Jacobs; also 845,890 of Feb. 26, 1907 to E. H. Binns; 1,002,301 of Sep. 5, 1911 to E. T. Newsome; 1,115,714 of Nov. 3, 1914 to T. D. Miller; 1,167,949 of Jan. 11, 1916 to P. M. Stewart.

² U. S. Pat. 838,232 of Dec. 11, 1906 to J. O. Ballentine.

³ U. S. Pats. 1,208,595 of Dec. 12, 1916 to W. F. McKay; 1,214,659 of Feb. 6, 1917 and 1,228,191 of May 29, 1917 both to W. P. Dun Lany.

⁴ U. S. Pat. 1,181,827 of May 2, 1916 to C. S. Bird; 1,250,577 of Dec. 18, 1917 to S. H. Goldberg.

squares or oblongs with a black paint;¹ applying a coating of asphalt in designs *over* a grit surfacing;² distributing crushed slate of two or more colors in adjoining squares, diamonds, hexagons, or other designs, to produce multi-colored effects;³ mixing mineral particles of different colors to impart a mottled appearance, etc.⁴

A different procedure consists in creasing 24-in. roofing sheets longitudinally 3 in. from the edges so that they may be laid over wooden

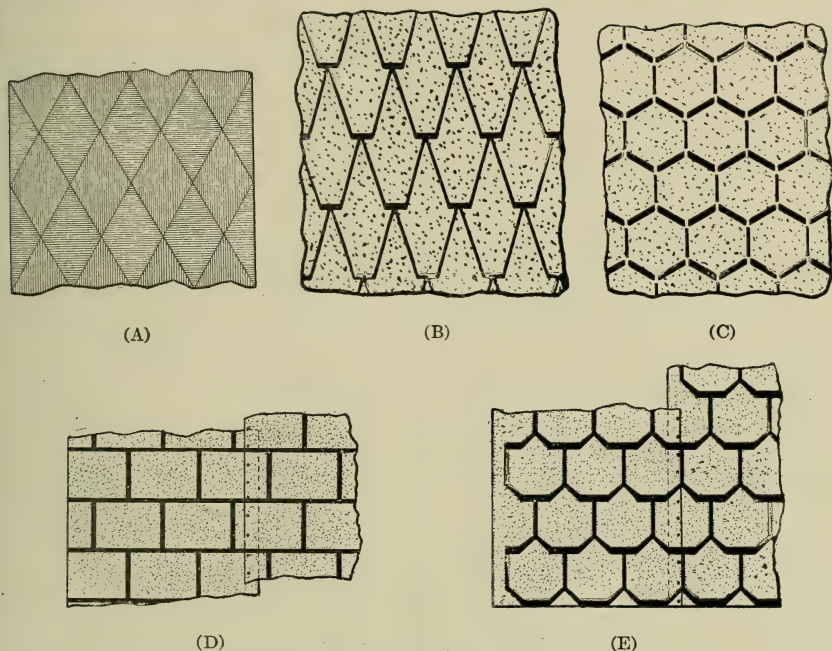

FIG. 134.—Roll Roofings Finished in an Ornamental Surface.

battens $1\frac{3}{4}$ in. square, spaced 20 in. from centres, and in this manner break up the surface by a number of standing seams intended to cast shadows.⁵

These decorative roofing sheets have become very popular in recent years. They are less expensive than composition shingles in view of the smaller amount of material required to cover 100 sq.ft. of roof surface,

¹ U. S. Pat. 1,222,594 of Apr. 17, 1917 to M. B. Becker.

² U. S. Pats. 1,024,549 and 1,024,550 of Apr. 30, 1912 to M. B. Becker.

³ U. S. Pats. 1,082,364 of Dec. 23, 1913 to A. S. Spiegel; 1,157,438 of Oct. 19, 1915 to A. S. Spiegel and L. F. Lindley; 1,194,890 of Aug. 15, 1916 to A. S. Spiegel; 1,254,481 of Jan. 22, 1918 to C. M. Clarke.

⁴ U. S. Pat. 1,134,086 of Mar. 30, 1915 to F. C. Lowrey.

⁵ U. S. Pat. 1,210,855 of Jan. 2, 1917 to R. L. Shainwald, Jr.

and are accordingly used where the price of individual shingles cannot be afforded.

Prepared Roofing Shingles. These represent a further development in prepared roofings, to produce decorative effects in imitation of wooden or slate shingles. This is brought about by cutting the roofing in diamond or rectangular units adapted to be laid in over-lapping courses.

One method consists in manufacturing sheets of roll roofing with a scalloped or "serrated" edge intended to be laid in courses so that the scalloped portions remain exposed to the weather.¹ This type of prepared roofing shingle has not proven very successful, as the long strips do not adequately provide for the expansion and contraction of the roof boards, and unless conditions are exactly right, the roofing is apt to wrinkle.

The foregoing objection is overcome by cutting the prepared roofing sheets in the form of *individual* shingles, usually in rectangular units. These may either be of uniform thickness,² or they may be tapered so the shingles will be thicker at the butts.³ One form is provided with a flap at the butt, adapted to be turned back and nailed underneath;⁴ another is formed with a portion of the shingle cut away on one side, resulting in what is known as a "self-spacing" shingle.⁵ As manufactured to-day, the standard size of individual shingles is 8 by $12\frac{3}{4}$ in., intended to be laid 4 in. to the weather and $\frac{1}{2}$ in. apart, requiring 424 shingles, or 300 sq.ft. of shingle surface weighing 220 lb., which is sufficient to cover 100 sq.ft. of roof surface in three thicknesses. Individual shingles are usually made with a slate surface from a No. 48 to 55 raw felt, and carry 23 to 38 lb. of slate surfacing per 100 sq.ft. of shingle surface, or 70 to 115 lb. per square of shingles. They are sometimes made from a No. 75 to 80 felt, and finished with a smooth surface.

A heavier and stiffer type of red or green slate-surfaced shingle is also manufactured weighing 240-250 lb. per square, comprising 424 shingles each measuring 8 by $12\frac{3}{4}$ in. In another modification, the shingles are multi-colored, the upper half being surfaced with red slate particles and the lower with green slate so that each shingle may be used to present either a red or a green surface depending upon

¹ U. S. Pats. 702,614 of June 17, 1902 to W. H. Bache; 742,614 of Oct. 27, 1903 to J. L. M. DuFour; 875,099 and 875,595 of Dec. 31, 1907, 876,009 of Jan. 7, 1908, 881,023 and 881,024 of Mar. 3, 1908, 891,500 of June 23, 1908, and 942,660 of Dec. 7, 1909, all to F. C. Overbury; 966,178 of Aug. 2, 1910 to J. L. M. DuFour; 978,333 and 978,334 of Dec. 13, 1910, 1,102,680 of July 7, 1914, and 1,130,368 of Mar. 2, 1915, all to F. C. Overbury; 1,126,932 or Feb. 2, 1915 to Herbert Abraham.

² U. S. Pats. 310,192 of Jan. 6, 1885 to J. T. Edson; 455,271 and 455,272 of June 30, 1891 to Hermann Bormann; 845,890 of Feb. 26, 1907 to E. H. Binns.

³ U. S. Pats. 394,033 of Dec. 4, 1888 to S. E. Trott; 877,019 of Jan. 21, 1908 to J. W. Troeger; 886,912 of May 5, 1908 to C. W. Young; 1,197,007 of Sept. 5, 1906 to F. M. Rauschhaupt; 1,191,932 Re. 14,387 of Oct. 30, 1917, to J. C. Loyer.

⁴ U. S. Pat. 1,104,998 of July 28, 1914 to F. C. Overbury.

⁵ U. S. Pat. 1,244,654 of Oct. 30, 1917, to A. S. Spiegel.

which half is exposed, or if desired variegated colored effects may be used by reversing the shingles at intervals. An attachment for cutting roll roofing into individual

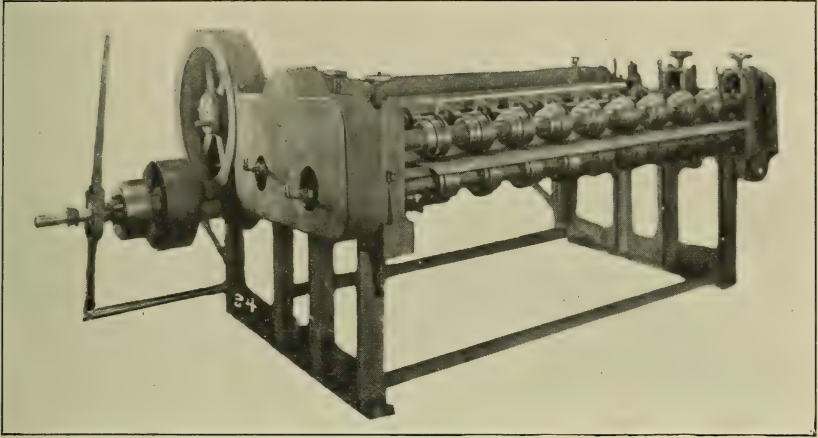

Courtesy of Guyton & Cumfer Mfg. Co.

FIG. 135.—Shingle Cutter—Front View.

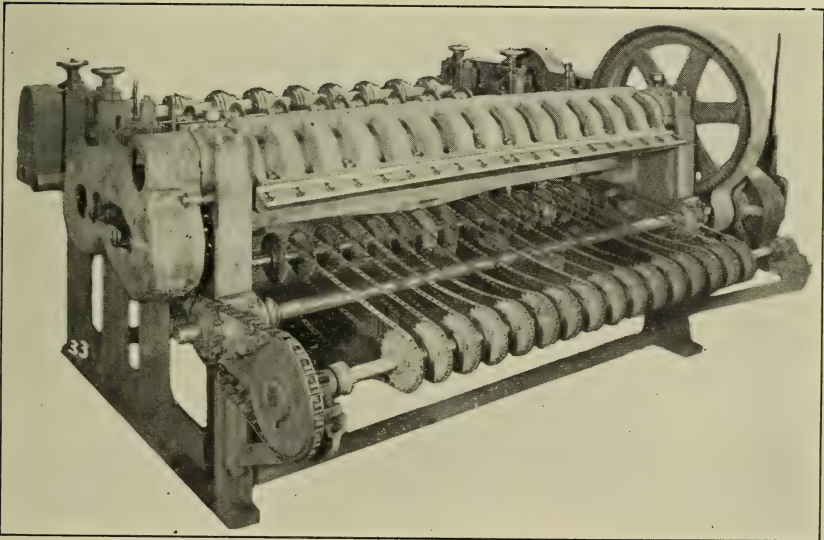

Courtesy of Guyton & Cumfer Mfg. Co.

FIG. 136.—Shingle Cutter—Rear View.

shingles is illustrated in Figs. 135 and 136. The sheet is first sliced into 8-in. longitudinal strips upon being fed through a gang of circular knives mounted on a

common shaft, and these in turn are severed into $12\frac{3}{4}$ in. units by a rapidly revolving transverse blade extending the full width of the machine.

Still another type is stamped from strips composed of a metal core to which sheets of waterproofed asbestos are fastened on either side by means of asphalt, as described on p. 409.¹

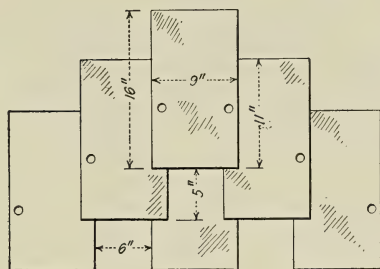

Courtesy of Flintkote Co.

FIG. 137.—Wide-spaced Shingles.

In another ramification the shingles are made in larger units (9 by 16 in.), to be exposed 5 in. to the weather on laying and spaced 6 in. apart as illustrated in Fig. 137.² This is known as the "wide-spaced method" and has the advantage of requiring less shingle area to cover 100 sq. ft. of roof surface. Thus, with the customary slate-surfaced fabric weighing 75 lb. per 100 sq. ft., it will take 192 9 by 16-in. wide-spaced shingles, or a total of 192 sq. ft. of shingle area, weighing 145 lb. to cover 100 sq. ft. of roof surface.

The so-called "multiple-shingle strip," consists of two or four units joined together in the form of a flat strip³ as illustrated in Fig. 138. The form having square butts $7\frac{1}{2}$ in. wide is made $32\frac{3}{8}$ in. long (over all) and 10 in. wide, with cut-outs 4 by $\frac{1}{2}$ in., and adapted to be exposed 4 in. to the weather. A square will include 112 shingle strips of 244 sq. ft. area, weighing 185 lb. A shingle strip is

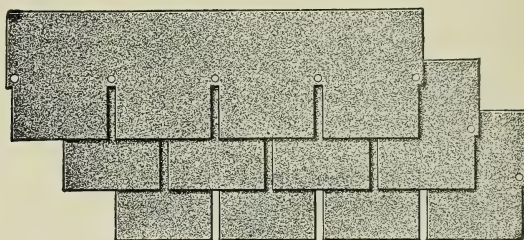

Courtesy of Flintkote Co.

FIG. 138.—Multiple Shingle Strip.

manufactured with diamond-shaped cut-outs extending back 4 in. from either edge (Fig. 139), and in units measuring $12\frac{3}{4}$ by $32\frac{3}{4}$ in. over-all. A square includes 112 shingle strips measuring 220 sq. ft. in area, and weighing 165 lb. A "reversible shingle strip" (Fig. 140A and B) is manufactured with the square butts on one side and diamond on the other, measuring $32\frac{3}{8}$ in. long and $12\frac{3}{4}$ in. wide over all. A square includes 112 shingles, measuring 260 sq. ft. in area, weighing 195 lb., and may be laid with either the square butts or the diamond points exposed, as desired. The advantages of the shingle strips are that they may be laid more rapidly than individ-

¹ U. S. Pat. 1,059,682 of Apr. 22, 1913 to T. D. Miller.

² U. S. Pat. 1,145,440 of July. 6, 1915 to Calvin Russell.

³ U. S. Pats. 891,501 of June 23, 1908, 908,125 of Dec. 29, 1908, 1,150,298 of Aug. 17, 1915, all to F. C. Overbury; 1,207,523 of Dec. 5, 1916, 1,209,955 of Dec. 26, 1916 both to S. M. Ford; 1,219,652 of Mar. 20, 1917 to W. F. McKay; 1,243,064 of Oct. 16, 1917 to O. A. Heppes.

ual shingles, due to the fact that two or more units are coupled together, also that it will take a smaller quantity of roofing to cover a 100 sq.ft. of roof area. The appearance of the roof when laid is substantially the same as in the case of individ-

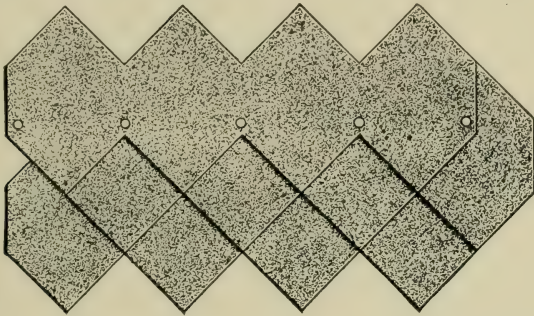
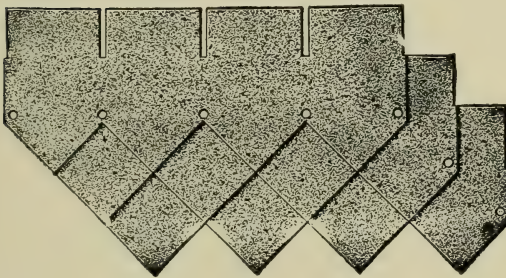
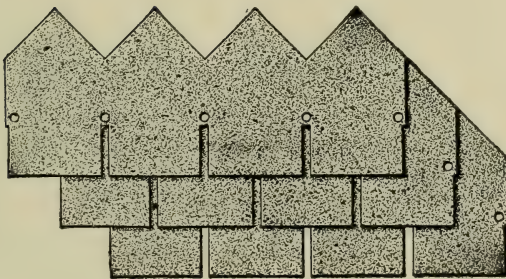

FIG. 139.—Diamond Shingle Strip.

Courtesy of Flintkote Co.



(A)



(B)

FIG. 140.—Reversible Shingle Strip.

Courtesy of Flintkote Co.

ual shingles, but it is not protected with as many layers of fabric, for obvious reasons.

Fastening Devices. Sheets of prepared roofing were originally fastened to the roof boards by means of $\frac{7}{8}$ to 1-in. steel nails, driven

through convex discs composed of American terne plate (thickness IX), $\frac{7}{8}$ to 1 in. in diameter, the nails being spaced 2 in. from centres. Discs formed of prepared roofing,¹ square caps of enameled metal having a raised centre portion,² steel discs fastened directly to the tops of wire nails (known as the "simplex roofing nail") were next proposed.

At the present time the "caps" have been almost entirely replaced by large-headed roofing nails, of which two types are in vogue, viz.:

	Diameter of Head.	Diameter of Shank.	Length of Shank.
American felt roofing nails.....	$\frac{3}{16}$ in.	$\frac{3}{32}$ in.	$\frac{1}{2}$ in.
Barbed No. 10 roofing nails....	$\frac{1}{8}$ in.	$\frac{1}{8}$ in.	$\frac{1}{2}$ in.

For the better grades of roofing, the nails should either be sherardized or galvanized, and protected with not less than $37\frac{1}{2}$ mg. zinc per square centimeter, corresponding to $1\frac{1}{4}$ oz. per square foot of surface.³ Sherardizing is preferable to galvanizing, as it affords better protection to the steel, assuming that equal weights of zinc are applied in both cases, and forms a coating that will not chip or flake off should the nail shank or head bend. This is very likely to occur at the junction of the shank and head when the nail is driven in place. A well-sherardized nail will withstand the weather under normal conditions from ten to fifteen years, without further protection, and in the author's opinion constitutes the most satisfactory means of rust-proofing.

With cheaper prepared roofings, it is customary to furnish the nails in the "bright" form, i.e., without being treated, but it then becomes necessary to protect the heads when hammered into place, with a liberal coating of "lap cement" (p. 470). Although the latter will tend to *retard* corrosion of the steel, the practice is not to be recommended, where the durability of the roof is an important consideration.

Other metal fasteners include flat or formed tapes intended to be nailed at intervals;⁴ long strips with spaced perforated concave portions;⁵ short strips reinforced by having the centre portion raised, and capable of accommodating four nails, illustrated in Fig. 141, known as "roofing cleats".⁶

¹ U. S. Pat. 742,589 of Oct. 27, 1903 to B. G. Casler.

² U. S. Pat. 816,522 of Mar. 27, 1906 to G. R. Wyman.

³ If a represents the diameter of the nail head, b the average length of the shank, and c the diameter of the shank, then the total area of the nail's surface will be equal to:

$$\frac{11}{7}a^2 + \frac{22}{7}bc.$$

⁴ U. S. Pat. 348,844 of Sept. 7, 1886 to David Harger.

⁵ U. S. Pats. 887,532 of May 12, 1908 to H. B. Sherman; 967,208 of Aug. 16, 1910 to J. F. Leslie.

⁶ U. S. Pats. 973,902 of Oct. 25, 1910 to W. H. Woerheide; 981,362 of Jan. 10, 1911 to J. H. Bell; 985,501 of Feb. 28, 1911 to J. H. Bell; 1,017,611 of Feb. 13, 1912 to H. R. Wardell (Federal Reporter of Jan. 12, 1915, 215, 604); and 1,187,532 of June 20, 1916 to H. C. Kettelson.

Less expensive fastening devices consist of sherardized or galvanized wires which may be looped at intervals,¹ or composed of a series of spaced, perforated flattened areas² as illustrated in Fig. 142. Another fastener consists of an N-shaped piece of wire having one limb pointed for driving into the boards, the other ending in a small loop intended to be bent over the edge of the sheet at the seam. A similar device has been proposed for fastening shingles,³ consisting of a metal strip nailed underneath the shingle with one end projecting beyond the shingle and intended to be bent over the butt. Another shingle fastener is composed of grooved strips of metal to be inserted in between adjacent shingles.⁴

Many methods have been devised for protecting the seams and covering the nail heads, as for example folding back the upper sheet of roofing after forming the seams;⁵ driving the nails through the *under* sheet of roofing only, and then cementing the upper sheet over the nails heads;⁶ forming the roofing sheets with

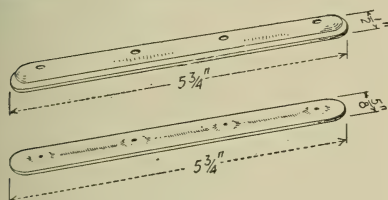
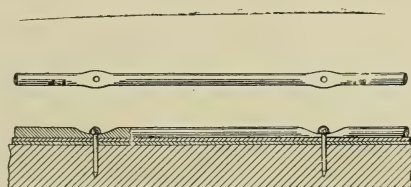

Fig. 141.—Types of Roofing "Cleats."



Courtesy of The Standard Paint Co.
Fig. 142.—Wire Roofing Fastener.

bevelled edges;⁷ providing the edges of the sheets with one or more flaps composed of burlap, metal, or the same material as the roofing itself, intended to be folded over the nails heads and fastened with liquid lap-cement. The last is known as "concealed nailing."⁸

Methods of Forming Roll Roofing Packages. Roll roofings are prepared for shipment by winding them on the outside with a heavy paper "wrapper," and packing the "fixtures" consisting of the nails and can of "lap cement" in the core of the roll. Various devices have been used for holding the fixtures in place, including sheets of cloth or heavy paper pasted over the ends; cylindrical plugs of wood driven in

¹ U. S. Pats. 757,193 of Apr. 12, 1904 and 778,863 of Jan. 3, 1905 to F. S. Howard; 1,242,675 of Oct. 9, 1917 to S. M. Ford.

² U. S. Pats. 1,237,270 of Aug. 21, 1917 to Herbert Abraham; and 1,225,972 of May 15, 1917, to H. C. Kettelson.

³ U. S. Pat. 978,334 of Dec. 13, 1911 to F. C. Overbury.

⁴ U. S. Pat. 1,153,152 of Sept. 7, 1915 to Francis Brucker.

⁵ U. S. Pat. 60,708 of Jan. 1, 1867 to C. J. Fay.

⁶ U. S. Pat. 713,588 of Nov. 18, 1902 to John Ayrault.

⁷ U. S. Pat. 813,163 of Feb. 20, 1906 to W. J. Moeller.

⁸ U. S. Pat. 632,825 of Sept. 12, 1899 to R. J. Redick; 636,022 of Oct. 31, 1899 to G. D. Crabbs and W. H. Pendery; 652,150 of June 19, 1900 to F. W. Terpenning; 669,315 of Mar. 5, 1901 to D. P. Whitmore; 835,889 of Nov. 13, 1906 to W. J. Moeller; 855,757 of June 4, 1907 to G. D. Crabbs and W. H. Pendery; 868,930 of Oct. 22, 1907 to A. E. Kirk; 984,860 of Feb. 21, 1911 to F. E. Smith.

the openings at the end of the roll and fastened together with wire;¹ using a paper wrapper wider than the roll, turning over the edges into the core and wedging into place with cylindrical plugs;² sealing the openings of the core with plaster of paris plugs;³ constructing the openings of the core by driving wooden wedges between the convolutions at the ends of the roll;⁴ covering the ends of the roll with wooden discs wired together;⁵ covering the ends with metal discs wired together;⁶ covering the ends with metal discs fastened together with a light metal rod;⁷ metal discs held in place by projecting flanges;⁸ packing the fixtures in an elongated cylindrical cardboard case, which at the same time serves as a mandrel for the roll;⁹ wrapping the nails and can of lap-cement in a paper or cloth package provided with a flap which is inserted between the inner convolutions of the roll of roofing as the sheet is wound on the machine¹⁰ etc. Most of the rolls shipped at the present time are protected with "heads," of cloth pasted in place.

Method of Laying Prepared Roofings and Shingles. Prepared roofings may either be laid in a single course, or in a so-called "built-up" form, composed of two or more bituminated sheets constructed on the roof of the building. The single course method is adapted only for application over wood, whereas built-up roofs are equally suitable for use over wooden or concrete roof decks.

Laying the Fabrics in a Single Course. In this case the sheets are laid with 2-in. seams and cross-seams, the joints being sealed with liquid lap-cement, and fastened with large headed nails, or with any of the other devices described. The usual method of forming the seams is illustrated in Fig. 143 (*A* and *B*). The same method is followed in laying single- or multiple-layered bituminated roofing sheets in one course. Where the sheet is surfaced with moderately fine mineral matter on but one side, it is advisable to lay this *against* the roof boards.¹¹ A single course of multiple-layered roofing, composed of burlap cemented between two layers of asphalt-saturated and coated felt is introduced

¹ U. S. Pat. 694,304 Feb. 25, 1902 to C. S. Bird and J. B. Hanscom.

² U. S. Pat. 803,713 of Nov. 7, 1905 to H. M. Reynolds.

³ U. S. Pat. 852,397 of Apr. 30, 1907 to W. P. Penney.

⁴ U. S. Pat. 713,938 of Nov. 28, 1902 to W. H. Bache.

⁵ U. S. Pat. 873,046 of Dec. 10, 1907 to F. S. Howard.

⁶ U. S. Pat. 742,558 of Oct. 27, 1903 to W. H. Bache; 874,160 of Dec. 17, 1907 to Purlan Buckborough.

⁷ U. S. Pats. 825,239 of July 3, 1906 to M. C. Ohnemus; 919,607, 919,608 and 919,739 of Apr. 27, 1909, and 923,362 of June 1, 1909, all to G. W. Loughman.

⁸ U. S. Pats. 996,510 and 996,511 of June 27, 1911, both to G. J. Oetsch.

⁹ U. S. Pat. 980,406 of Jan. 3, 1911 to B. G. Casler.

¹⁰ Canadian Pat. 143,374 of Oct. 15, 1912 to C. W. Dohm.

¹¹ U. S. Pat. 840,103 of Jan. 1, 1907 to R. W. Bird.

between two layers of sheathing boards for covering freight cars, the function of the upper layer being to protect the roofing from injury.¹

*Roofs Constructed of Two or More Courses of Fabrics.*² If used over wood, it is customary to first install a layer of sheathing paper (not necessarily bituminized), to prevent the melted compound from dripping into the building, also to purpose'y separate the built-up roof from the wooden boards, thus allowing the latter to shrink without danger of tearing the roofing. This layer of sheathing paper should *not* be included in counting the total number of courses or "plies" in the built-up roof.

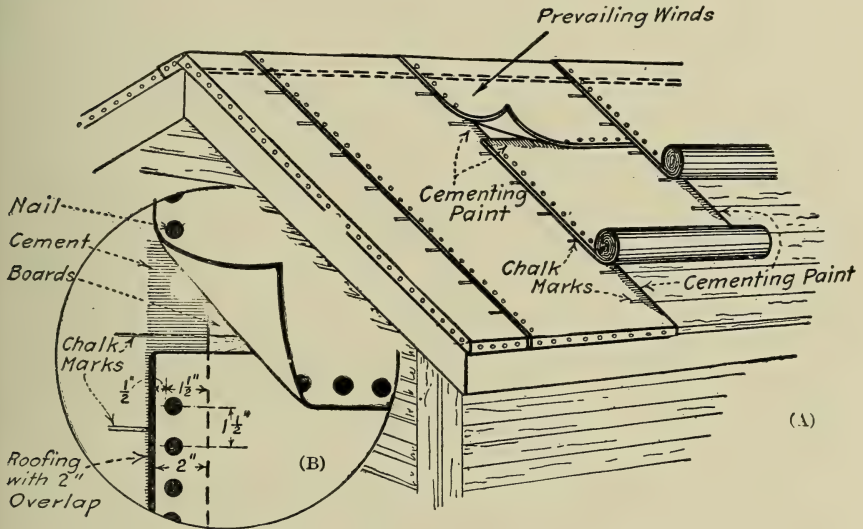

Courtesy of The Standard Paint Co.

FIG. 143.—Laying Roll Roofing in Single Course.

A 2-ply built-up roof laid over wood and concrete respectively, composed of two courses of prepared roofing, is shown in Fig. 144 (A and B). A 3-ply built-up roof laid over wood and concrete composed of 1 course of asphalt-saturated felt with 2 courses of single layered prepared roofing, is shown in Fig. 145 (A and B). The built-

¹ U. S. Pat. 845,414 of Feb. 26, 1907 to Samuel Herbert.

² U. S. Pats. 40,542 of Nov. 3, 1863 to L. S. Mills and C. H. Smith; 61,878 of Feb. 5, 1867 to John Scanlon; 147,962 reissue 8414 of Sept. 10, 1878; 179,131 of June 27, 1876 to Lewis Peirce; 270,943 of Jan. 23, 1883 to S. L. Foster; 296,163 of Apr. 1, 1884 to Levi Haas and Dennis Howarth; 331,971 of Mar. 17, 1885 to T. H. White; 677,058 of June 25, 1901 to Emil Borgeson and Axel Wennerberg; 712,193 of Oct. 28, 1902, to F. L. Kane; 798,131 of Aug. 29, 1905 to F. W. Gezelschap and Arthur Winding; 842,079 of Jan. 22, 1907 to E. R. Campbell; 846,572 of Mar. 12, 1907 to C. J. Kunzler; 1,230,396 of June 19, 1907 to F. L. Foster.

up roofs may be finished "smooth" as shown in the figures, or they may be flooded with melted bituminous compound and slag or gravel embedded therein while the compound is hot.

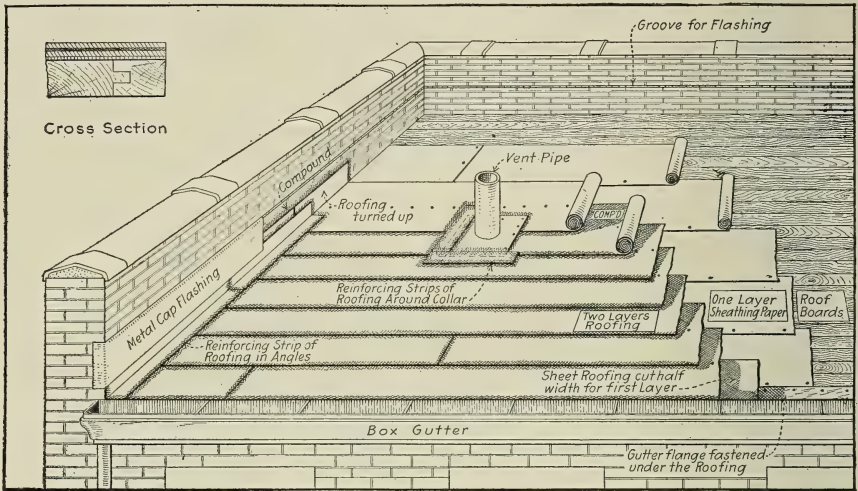

(A)

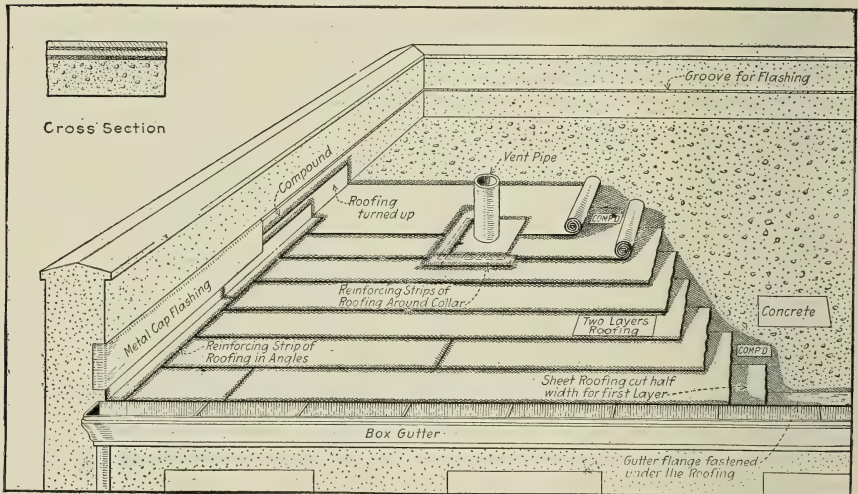

(B)

Courtesy of The Standard Paint Co.

FIG. 144.—Two-ply Built-up Roofs over Wood and Concrete.

A well-known type of 5-ply roof constructed of tarred felt cemented together with coal-tar pitch and surfaced with either slag or gravel, laid over wood and concrete respectively, is shown in Fig. 146 (A and B).

Laying Shingle Roofs. It is customary to lay 8 by 12 $\frac{3}{4}$ in. prepared roofing shingles by exposing them 4 in. to the weather, as illustrated in Fig. 147, which will be found self-explanatory.

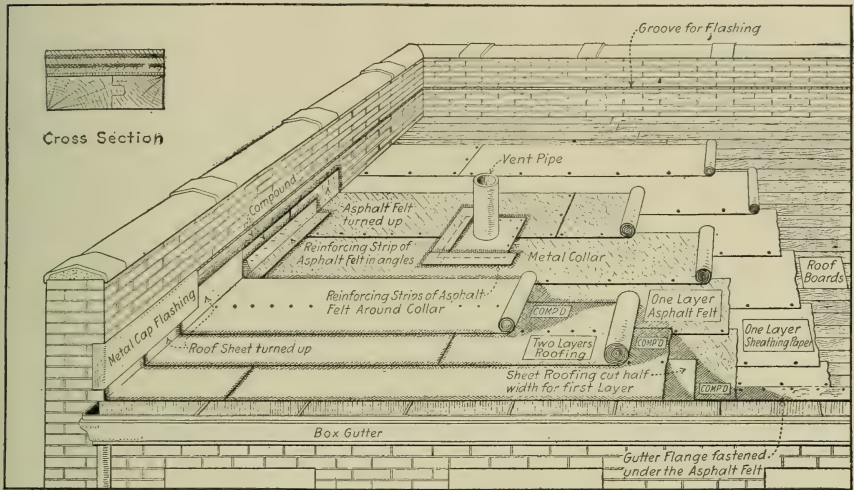

(A)

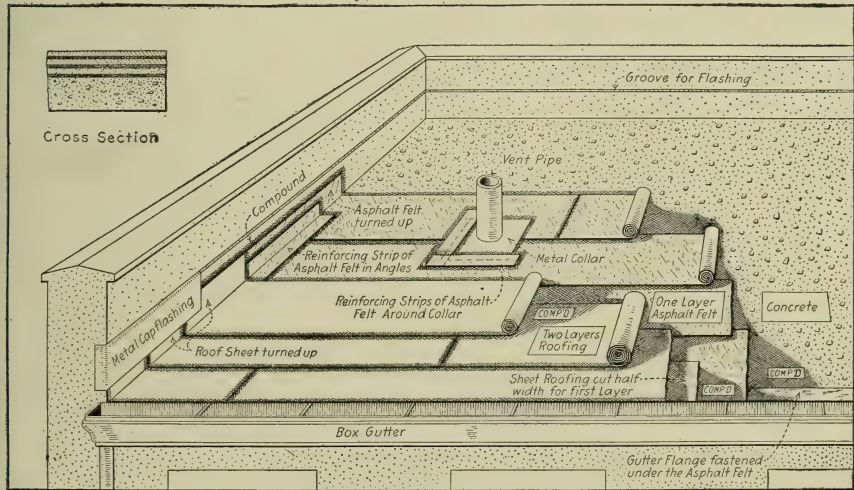

(B)

Courtesy of The Standard Paint Co.

FIG. 145.—Three-ply Built-up Roofs over Wood and Concrete.

Rating of Prepared Roofings and Shingles by the Underwriters' Laboratories, Inc., The Underwriters' Laboratories, Inc., of Chicago, established and maintained

by the National Board of Fire Underwriters, classify fire retardant roofings into three groups,¹ viz.:

Class A. Includes roof coverings which are effective against *severe* fire exposures. Under such exposures, roof coverings of this class are not readily flammable, and do not carry or communicate fire; afford a fairly high degree of heat insulation to the roof deck; do not slip from position; possess no flying brand hazard; and do not require frequent repairs in order to maintain their fire-resisting properties.

This class includes the following types:

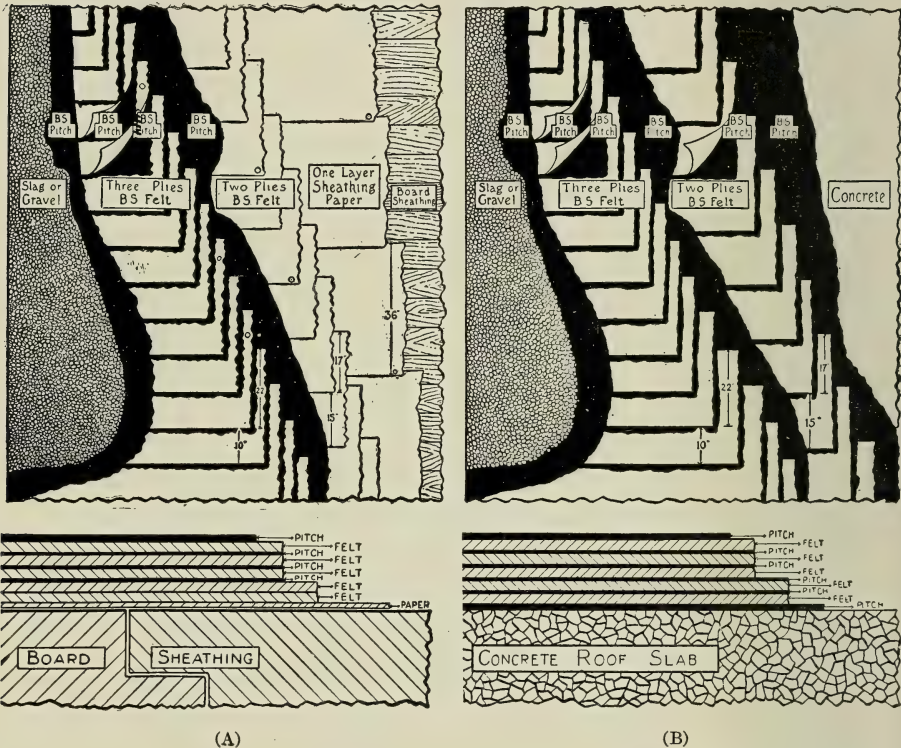

(A)

(B)

Courtesy of Barrett Company.

Fig. 146.—Five-ply Built-up Roofs over Wood and Concrete.

(1) Five-ply built-up roofs composed of coal-tar- or asphalt-saturated rag felt surfaced with bricks, tiles, cement, gravel or slag, containing 80 to 85 lb. of tar or asphalt saturated rag felt, 150–200 lb. of coal-tar pitch or asphalt, not less than 400 lb. of gravel or 300 lb. of slag per 100 sq.ft., and limited to combustible or non-combustible roof decks, having inclines not exceeding 3 in. to the foot, horizontal.

¹ Bulletin dated June 29, 1916; also list of Inspected Mechanical Appliances issued by the Underwriters' Laboratories, Inc., July, 1917.

(2) Three-ply built-up roofs containing not less than 40 lb. of asphalt-saturated asbestos felt, and 37 lb. of asphaltic cement per 100 sq.ft., and limited to non-combustible roof decks with inclines not exceeding 6 in. to the foot horizontal. Also 4- and 5-ply built-up roof coverings containing not less than 60 lb. of asphalt-saturated asbestos felt and 45 lb. asphaltic cement per 100 sq.ft., and limited to combustible or non-combustible roof decks with inclines not exceeding 6 in. to the foot horizontal.

(3) A single course of laminated roofing composed of 4 sheets of asphalt-saturated asbestos felt, cemented together with an asphaltic adhesive, weighing not less than 60 lb. per 100 sq.ft., and limited to combustible or non-combustible roof decks, with inclines exceeding 3 in. to the foot horizontal.

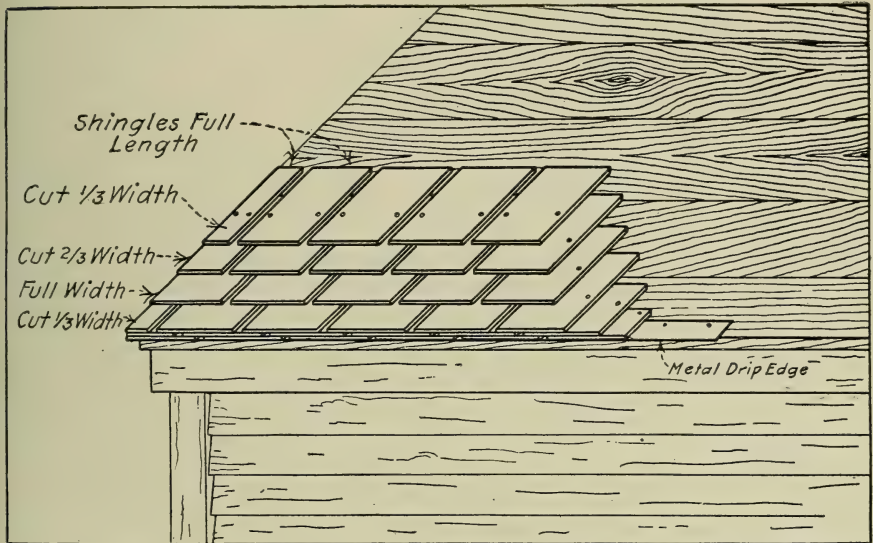

Courtesy of The Standard Paint Co.

FIG. 147.—Laying Individual Shingles.

Class B. Includes roof covering which are effective against *moderate* fire exposures. Under such exposures, roof coverings of this class are not readily flammable, and do not readily carry or communicate fire; afford a moderate degree of heat insulation to the roof deck; do not slip from position; possess no flying brand hazard; but may require occasional repairs in order to maintain their fire-resisting properties.

Bituminous roof coverings falling in this class include:

(1) Three-ply built-up roofs containing not less than 48 lb. of coal-tar- or asphalt-saturated rag felt, 90 lb. of coal-tar pitch or asphaltic adhesive, 400 lb. of gravel or 300 lb. of slag per 100 sq.ft., and limited to combustible or non-combustible roof decks, having inclines not exceeding 3 in. to the foot horizontal.

(2) Three-ply built-up roofs containing not less than 46 lb. of asphalt-saturated asbestos felt, and 40 lb. of asphaltic adhesive, limited to combustible and non-

combustible roof decks, capable of receiving and retaining nails, and to inclines not exceeding 6 in. to the foot horizontal.

(3) Three-, 4- or 5-ply built-up roofs containing both asphalt-saturated asbestos and rag felts cemented together with an asphaltic adhesive. Various specifications are approved for this class of coverings. The 5-ply may be used on combustible roof decks, and is limited to inclines not exceeding 3 in. to the foot horizontal; the 4-ply may be used on combustible roof decks but is limited to inclines not exceeding 3 in. to the foot horizontal; and the 3-ply is limited to non-combustible roof decks, and to inclines not exceeding 3 in. to the foot horizontal.

(4) A single course of laminated roofing composed of either two or three sheets of asphalt-saturated asbestos felt cemented together with asphaltic adhesive, weighing not less than 45 lb. per 100 sq.ft., and limited to combustible and non-combustible roof decks capable of receiving and retaining nails, and to inclines exceeding 3 in. to the foot horizontal.

Class C. Includes roof coverings which are effective against *light* fire exposure. Under such exposures, roof coverings of this class are not readily flammable, but may carry and communicate fire; afford at least a slight degree of heat insulation to the roof deck; do not slip from position; may possess a slight flying brand hazard; and may require fairly frequent repairs or renewals in order to maintain their fire-resisting properties.

This class includes one course of 2- or 3-ply (heavy and extra heavy) single-layered prepared roofing composed of asphalt-saturated and coated rag felt (finished with either a smooth, sanded or grit surface); also prepared roofing shingles composed of asphalt-saturated and coated rag felt (finished with either a smooth, sanded or grit surface). These are limited to combustible and non-combustible roof decks, capable of receiving and retaining nails, and to inclines exceeding 3 in. to the foot horizontal in the case of roll roofings, and exceeding 4 in. to the foot horizontal in the case of shingles.

In brief, the following minimum requirements are proposed by the Underwriters' Laboratories, Inc. for the Class C roofings:

Dry felt to be uniform in thickness, texture and quality, averaging not less than 10.4 lb. per 100 sq.ft. (corresponding to No. 50 on felt maker's scale), with a minimum weight of 10 lb. (corresponding to No. 48).

Saturating and coating compounds to be of an asphaltic nature, having a flash-point of not less than 210° C. (410° F.) by the Pensky-Martens closed-cup method and an ignition-point of not less than 400° C. (752° F.) as determined by the Underwriters' Laboratories' standard method.

Surfacing materials to be non-combustible, including talc, soapstone, mica, slate, rock, sand, pebbles, gravel, terra cotta, crushed vitreous materials, etc. The dusting powder should not exceed 3 lb. per 100 sq.ft. The coarse surfacing materials to be free from dust, or foreign matter which would interfere with their adhesion, and to be well embedded in the coating compound.

Nails to be galvanized, and not less than $\frac{3}{4}$ in. long for roll roofings, and 1 in. long for shingles. Bright nails when exposed to the weather should be protected with a rust-proof coating.

Smooth-surfaced roll roofings to average not less than 37 lb. per 100 sq.ft. (exclusive of nails and cement) with a minimum of 34.5 lb.

Grit-surfaced roll roofings to average not less than 37 lb. per 100 sq.ft. (exclusive of surfacing material, nails and cement), with a minimum of 34.5 lb.

Individual and strip shingles to be in such form, shape and size that there will be at least one thickness of roofing material at the thinnest point when laid, and that no portion of the deck boards will be exposed upon cutting away the weather portion of the shingles or strips along a line through the nails in the strips which secure them to the roof deck. The average weight of a single thickness of the shingles exclusive of surfacing material, wrappers, and fixtures shall not be less than 37 lb. per 100 sq.ft. with a minimum of 34.5 lb.

Multiple-layered prepared roofings and shingles to be composed of two or more thicknesses of asphalt-saturated rag felt, cemented together and coated with an asphaltic material, with or without mineral surfacing. These are to comply in all essential particulars with the requirements for prepared roofings and shingles composed of a single thickness of felt.

The foregoing classifications exclude wooden shingles, which constitute the greatest competitor of prepared roofings. Figures compiled by the U. S. Dept. of Agriculture ¹ indicate that from 1904 to 1912 the output of wooden shingles in the

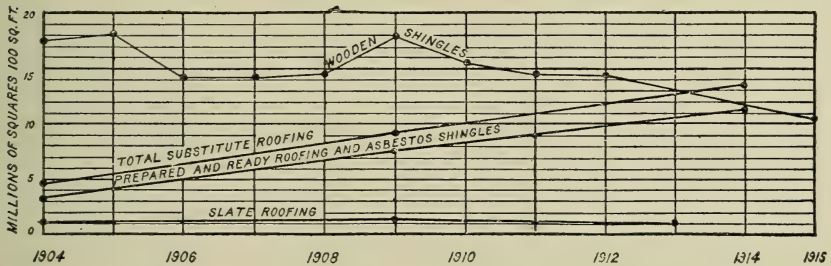

FIG. 148.—Chart of Annual Production of Roofings in the U. S.

United States fell from 17½ to 14½ million squares, and from 1909 to 1915 from 18 to 12¼ million squares; further, that the production of substitute roofings (including prepared roofings, prepared roofing shingles, slate, tile, etc.) increased from 4½ to 13½ million squares from 1904 to 1914. This is illustrated graphically in Fig. 148. The total production of the substitute roofings manufactured in 1914, estimated at 13,605,835 squares (excluding tar and gravel roofs), is apportioned as follows:

Cement, tile and miscellaneous.....	0.4%
Slate tile.....	1.1%
Asphalt shingles.....	2.4%
Metal shingles and tiles.....	6.3%
Slate (1913).....	8.2%
Prepared roofings, including asbestos roofings and shingles.....	81.6%
Total.....	100.0%

The author estimates that in 1917 there were produced 20 million squares of composition roll roofings and 2 million squares of composition shingles.

¹ Rept. No. 117 the "Substitution of other Materials for Wood Study of the Lumber Industry," Part XI, by Rolf Thelan, Washington, D. C., 1917.

BITUMINIZED FLOOR COVERINGS

Methods of Manufacturing. These first appeared on the market in 1910 as a substitute for linoleum, and have since enjoyed steadily increasing sale, due to their lower price, superior waterproof properties and remarkable resistance to wear and tear under foot. They are prepared from an asphalt-saturated rag felt printed on the surface in colored patterns, manufactured with or without a backing of burlap, and in all cases faced on the underside with a suitable paint or wash.¹ When burlap is used, the asphalt-saturated felt may be regarded as replacing the central layer of oxidized linseed oil, resins, wood flour, powdered cork, colored pigments and mineral filler ordinarily employed in manufacturing printed linoleums. Where no burlap is used, the asphalt-saturated rag felt may be viewed as the equivalent of both the central layer and burlap backing.

The bituminized floor covering is less frequently composed of an asphalt-saturated rag felt carrying a moderately thick layer of the linoleum composition (oxidized linseed oil, resins, wood flour, powdered cork, colored pigments and filler) on the surface, and the usual paint or wash on the back.²

In manufacturing the floor covering, a sheet of rag felt of high tensile strength, great uniformity in texture and thickness, is first saturated with an asphaltic mixture having a somewhat higher fusing-point and greater hardness than used for manufacturing roofing (p. 391). The asphalt-saturated felt prepared in this manner is first allowed to season, and then sized on the upper surface with an aqueous solution of some glutinous substance, such as wheat or rye flour, casein,³ animal glue and silicate of soda,⁴ or the like, with or without the admixture of a suitable filler, such as ground shale (known commercially as "talckene"), clay, siliceous minerals, etc. The function of the sizing coat is to prevent the dark-colored hydrocarbons in the felted fabric from working their way through and discoloring the paint subsequently applied to the surface.

When the size is dry, the fabric is "primed" or "filled" with a mixture composed of 2 to 4 parts of "gloss oil"⁵ and 1 part of com-

¹ U. S. Pat. 1,184,584 of May 23, 1916 to W. D. Snow.

² U. S. Pat. 1,132,647 of Mar. 23, 1915 to E. L. Blabon.

³ U. S. Pat. 1,176,853 of Mar. 28, 1916 to George Prifold; Ger. pat. appl. 72,226 of Feb. 13, 1913 to the Barrett Manufacturing Co.

⁴ U. S. Pat. 1,008,296 of Nov. 7, 1911 to Judd Smith.

⁵ Consisting of linseed oil which has been heated to a temperature in the neighborhood of 350° F. with 1 to 2 per cent of red lead, litharge, or other suitable dryers, until the oil assumes the consistency of heavy molasses.

mercial "boiled" linseed oil, ground through a paint mill with a mixture of filler and yellow ochre, and thinned to spreading consistency with a volatile petroleum distillate. The function of the ochre is to impart a so-called "linoleum" color to the mixture. The filler and pigment should be added in sufficient quantity to cause the paint to assume a "flat" finish on drying, and the petroleum distillate to reduce the mixture of oil and pigments to proper spreading consistency. The priming coat is applied either to one or both surfaces of the sized bituminized fabric by running it through a pair of rollers or in some cases a set of rubber or leather squeegees.

The sheet is then festooned in a steam-heated drying chamber, maintained at 110 to 140° F., until the priming coat has dried hard, whereupon it is passed through a set of "grinding rolls" composed of a suitable abrasive, to smooth and level it off.

Method of Printing and Graining. If the flooring is to be finished in designs to produce what is known to the trade as "print goods," it is next passed through a printing machine of the type ordinarily used for manufacturing linoleum, which will apply two or more colors in predetermined patterns or designs. These may be varied at will by changing the "print blocks" or dies used on the machine. The colored printing mixture contains suitable proportions of "gloss oil," mixed with colored pigments in quantities sufficient to color the mixture, but not to overcome the gloss when dry. The printed goods are again festooned in the drying chamber where they are allowed to remain until the surface coating dries hard.

In manufacturing "grained" floor coverings in imitation of wood, the sized and primed fabric after being smoothed and levelled, is passed through a "Posselius" graining machine, which applies colored paint in the form of a graining to imitate the wood selected. This is allowed to dry and the surface finished with a coat of high-grade floor varnish, in some cases containing "gloss oil" when it is desired to increase the pliability of the finishing coat. The fabric is then suspended in the drying oven and heated until hard and tough.

The reverse side of the flooring is usually surfaced in a dull red tint, similar to that used for finishing burlap-backed linoleum. Two general methods are followed. One consists in coating the under side of the asphalt-saturated felt with the red paint after it has been sized, but before the priming coat, which is thereupon applied to the upper surface only. An alternative method consists in simultaneously coating both the upper and lower surfaces of the sized fabric with priming coats, drying, and then applying the red paint to the back. In either case the red paint consists of a mixture of rosin varnish, gloss oil, boiled linseed oil, ground shale or other filler, mixed with sufficient red iron oxide, to impart the desired shade, and thinned with petroleum distillate to spreading consistency.

The raw felt used ranges from No. 36 to No. 60; the asphalt-saturated product weighs from 16-32 lb. per 100 sq.ft.; the combined weight of the coats of paint

on the front and back surfaces 10 to 15 lb. per 100 sq.ft.; the finished weight of flooring (when manufactured without an intermediate layer of linoleum composition) 25 to 45 lb. per 100 sq.ft.; the thickness of the coats of paint $1\frac{1}{2}$ -2 mils; the thickness of the finished product 50-75 mils; and the dimensions of the rolls as marketed 74 in. by 30-33 yds.

Bituminized floor coverings after being sized are sometimes coated with a moderately thick layer of linoleum composition, containing oxidized linseed oil, resins, ground cork or wood flour, mineral fillers, and colored pigments. This linoleum layer may be applied in patterns of variegated colors running all the way through, known to the trade as "inlaid" goods, or it may be applied in a uniform color, and the surface printed as in the foregoing. Floorings having the patterns printed directly on the sized and primed felt are less expensive, and from all reports wear better than the type carrying the intermediate layer of linoleum composition.

Bituminized floorings are also marketed in the form of rugs, with a border printed around the edges,¹ in some cases reinforced with a marginal stitching embedded underneath the surface-coating.²

WATERPROOFING MEMBRANES

The term "membrane" as applied to waterproofing was originally suggested by E. W. DeKnight, and alludes to a continuous sheet of bituminized fabric surrounding the structure to be waterproofed. The membrane system is also sometimes termed the "elastic" method, to distinguish it from the "integral" or "rigid" method of waterproofing (p. 457). The former is ordinarily used for waterproofing structures in the course of erection, and particularly the portion below ground level, including foundations of buildings, retaining walls, railway bridges, tunnels, subways, reservoirs, masonry tanks, swimming pools, etc. The fabric constituting the membrane may be felted or woven, or a combination of the two.

Materials Used. The materials ordinarily used for this purpose include the following:

Fabrics:

- (1) Tarred felt.
- (2) Asphalt-saturated felt.
- (3) Raw burlap or duck.
- (4) Tarred burlap or duck.
- (5) Asphalt-saturated burlap or duck.
- (6) Asphalt-saturated and coated felt surfaced with fine mineral matter, moderately coarse embedded mineral matter, wood-flour or sawdust.
- (7) A laminated sheet of bituminated fabric composed of bituminized felt, burlap or duck, used alone or in various combinations.

¹ U. S. Pat. 1,249,734 of Dec. 11, 1917 to F. B. Foster.

² U. S. Pat. 1,255,095 of Jan. 29, 1918 to R. G. Jackson.

Bituminous Adhesive Compounds:

(1) Coal-tar pitch or mixtures of coal-tar pitch with water-gas tar pitch.

(2) Asphaltic compounds.

The weight of felted fabrics used for waterproofing purposes varies widely, but the best practice provides that the dry felt shall not be less than No. 30 on the felt makers' scale (6.25 lb. per 100 sq.ft.) and the bituminized felt not less than 14 lb. per 100 sq.ft. Saturated and coated felts are also made in various weights ranging from 14 lb. to 70 lb. per 100 sq.ft.

Of the woven fabrics, burlap is generally employed, varying in weight from 10 to 20 oz. per square yard after saturation. The use of a cotton fabric is advocated instead of burlap, since cotton is less liable to rot on continuous contact with moisture, but on the other hand it is more expensive. Either the cotton or burlap may be made more resistant to decay by impregnation with a copper sulphate solution and drying before it is waterproofed with bituminous materials. Copper sulphate acts as a preservative and prevents the fibres hydrolyzing. The finished product should carry from 60 to 66 $\frac{2}{3}$ per cent of bituminous matter. No definite statements can be made regarding laminated fabrics composed of felt and burlap, since these vary widely in their structure and weights.

There has been much discussion whether coal tar or asphaltic products are superior for waterproofing masonry.¹ The present practice seems to favor the use of asphaltic products when they are to be subjected to air, sunlight or vibration, and the use of coal-tar products where the waterproofing is protected from these agencies. This conforms with the author's experience.

The following proposed tentative specifications (1917) for coal-tar-saturated felt have been proposed by Committee D-8 of the American Society for Testing Materials:

The saturant to be derived from pure coal tar; the finished product to weigh not less than 14 lb. per 100 sq.ft.; the material extractable with hot carbon disulphide shall not be more than 60 per cent nor less than 45 per cent; the loss on heating to 105° F. for twenty-four hours shall not exceed 6 per cent; the raw felt shall not contain less than 75 per cent of cotton and wool fibres; the tensile strength of a specimen 1 in. wide shall not be less than 25 lb. when cut in the direction of the length of the sheet, nor less than 10 lb. when cut across the sheet; the raw felt shall not contain more than 8 per cent of ash.

In the case of asphalt-saturated felt, the finished product shall not weigh less than 14 lb. per 100 sq.ft.; contain not exceeding 65 per cent nor less than 50 per cent

¹"Coal tar and Asphalt Products for Waterproofing," by S. T. Wagner, *Chem. Eng.*, **18**, 224, 1914.

extractable with carbon disulphide; lose not exceeding 2.5 per cent on heating to 105° F. for twenty-four hours, nor shall the product after this test be hard or brittle; the fibres present in the raw felt shall consist at least of 75 per cent of cotton and wool fibres; the tensile strength of a specimen 1 in. wide shall not be less than 25 lb. when cut in the direction of the length of the sheet, nor less than 10 lb. when cut across the sheet.

The American Society for Testing Materials (1917) proposes the following tentative specifications for creosote oil to be used as a priming coat in conjunction with coal-tar pitch:

The creosote oil shall be a pure tar distillate free from any substance foreign thereto; it shall be entirely fluid at 100° F.; its specific gravity at 100° F. shall not be less than 1.00 nor more than 1.06; it shall show less than 1 per cent insoluble in hot benzol; when distilled according to the standard method (p. 522) it shall yield not exceeding 2 per cent of water, not exceeding 5 per cent distilling under 200° F., not exceeding 50 per cent nor less than 30 per cent distilling under 235° C., and not exceeding 15 per cent of residue at 355° C. which must be soft in consistency. The specific gravity at 100° F. of the fraction distilling between 235 and 315° C. shall not be less than 1.00.

Similarly, the proposed tentative specifications for the primer to be used in conjunction with asphaltic adhesives, are as follows:

The primer shall consist of a paint containing an asphaltic base complying in every respect with the asphaltic adhesive compound (p. 422), thinned to ordinary paint consistency with petroleum distillate having an end point on distillation of not above 260° C., of which not more than 20 per cent shall distil under 120° C.

The specifications for coal-tar pitch and asphaltic adhesives are given in Chapter XXVI.

Preparing of the Underlying Surface. To insure the courses of bituminized fabric adhering properly to the underlying surface and to each other, the following precautions should be observed:

(1) Where the membrane is to be applied below grade, an adequate drainage system must be provided so that the masonry surface will be thoroughly *dry* during the installation of the waterproofing.

(2) It is of the utmost importance that the work should not be undertaken in rainy, snowy or very cold weather.

(3) Concrete surfaces should be brushed, scraped or chipped to remove all sharp projections which would puncture the waterproofing; also any dirt, foreign matter or cement which may have been raised to the surface during the placing of the concrete.

(4) Masonry surfaces should be primed with creosote oil when coal-tar products are to be used, or with an asphaltic paint when asphaltic products are to be used for waterproofing.

(5) Metal surfaces should be cleaned to remove all rust, scale, dirt or grease, and primed with a paint containing either coal-tar pitch or an asphaltic base, depending upon the character of waterproofing used.

(6) The floors of steel railroad bridges should first be covered with a 1 : 3 : 5 concrete containing $\frac{3}{4}$ in. stone or gravel, the surface of which when set and dry should be treated as specified in (3).

(7) When coated fabrics are used, the adhesion may be promoted by omitting the coating from one side of the saturated felt,¹ since the melted bituminous adhesive forms a better bond with plain saturated felt than felt surfaced with a bituminous coating of harder consistency.

(8) By surfacing saturated and coated felts with wood flour, fine sand, or sawdust, instead of talc, soapstone or other finely divided mineral filler, because the mineral powders exert a repellent action on the melted bituminous adhesive.

(9) When burlap is used in a single sheet, it is customary to manufacture it with the bituminous coating applied in such a manner that the meshes between the strands will remain open, the theory being that the melted adhesive will fill these and thus key itself more securely to the bituminized fabric.

(10) *Not less than 25 lb. of coal-tar pitch or asphaltic adhesive shall be applied per 100 sq.ft. of underlying fabric or masonry.*

Selecting and Installing the Waterproofing Membrane. Whether a felted or a woven fabric or a combination of the two is to be used, depends upon the character of the work and the preference of the engineer in charge. A woven fabric is more pliable, stronger, and less liable to tear or break when bent over sharp corners, but to counterbalance these, the felted fabric is less expensive, more durable and more resistant to moisture. Modern practice accordingly favors a combination of the two.

The number of courses of bituminized fabric to be applied depends upon the head of water encountered, the factor of safety sought and the views of the engineer in charge of the work. There is no standard practice followed in this connection. Where tarred- or asphalt-saturated felt weighing 14 lb. per 100 sq.ft. is used, the following figures will serve as a safe guide:

Hydrostatic Head.	Pressure in Pounds per Square Foot under Floor.	Average Pressure in Pounds per Square Foot against Side walls.	Number of Courses Tarred or Asphalt-satd. Felt to be Used.
0	0.0	0.0	2
1	62.5	31.2	3
2	125.0	62.5	4
6	375.0	187.5	5
8	500.0	250.0	6
10	625.0	312.5	7
15	937.5	468.7	8
20	1250.0	625.0	9

¹ U. S. Pat. 819,450 of May 1, 1906 to F. C. Overbury.

The fabrics should *always* be laid "shingle fashion," and *all* the layers applied in the *same* direction.

(a) When the membrane is to be composed of two courses, lay the fabric shingle fashion, lapping each course 1 in. more than half the width of the preceding one.

(b) When the membrane is to be composed of three courses, lay the fabric shingle fashion, lapping each course 1 in. more than one-third the width of the preceding one.

(c) When the membrane is to be composed of four courses, first cover the surface with two layers of fabric laid shingle fashion, lapping each course 1 in. more than half the width of the preceding one, and then follow with two additional courses installed in the same manner.

(d) When the membrane is to be composed of five courses, follow the procedures indicated in (b) and (a) respectively.

(e) When the finished membrane is to be composed of six courses, duplicate the procedure outlined in (b).

In the case of railroad bridges where the conditions are extremely severe, the following alternative specifications are recommended:¹

(1) From four to six courses of bituminized felt.

(2) A middle course of bituminized duck with two courses of bituminized felt on either side.

(3) A bottom course of bituminized felt, followed by two courses of bituminized duck with two upper courses of bituminized felt.

(4) Two or three courses of bituminized duck.

(5) Combinations of the foregoing with asphalt mastic (see Table XXXIII, p. 434).

The waterproofing specifications for subway construction issued by the Engineering Department of the Public Service Commission of the State of New York (Section 189), read as follows:

"The fabric must be rolled out into the pitch or asphaltum while the latter is hot, and pressed against it so as to insure its being completely stuck over its entire surface, great care being taken that all joints are well broken by overlapping, and that unless otherwise permitted, the ends of the rolls of the bottom layers are carried up on the inside of the layers on the side, and those of the roof down on the outside of the layers on the side, so as to secure a full lap of at least 1 ft. Especial care must be taken with this detail."

It is extremely important that the work should be *continuous*. A lack of continuity will be fatal to any membrane, since the water is sure to find its way through. Each layer of pitch, asphalt or other adhesive should *completely* cover the surface over which it is spread, without breaks, blow-holes or other imperfections. The fabric must be rolled out smoothly, and pressed into the hot cementing material, to insure its sticking thoroughly and evenly. Where it becomes necessary to temporarily discontinue the work, laps at least 12 in. wide must be provided to join with the ensuing section of the waterproofing. On walls connecting with floors, the ends of the floor layer should be carried through the wall and turned upwards outside, whereupon the fabric on the outside of the walls should be carried down over the ends of the floor layer, lapping at least 12, and preferably 24 in.

¹ "The Waterproofing of Solid Steel-floor Railroad Bridges," by S. T. Wagner, *Proc. Am. Soc. Civil Eng.*, 79, 306, 1915.

On connecting the wall with the roof work, the layers of fabric from the roof should be carried down over the outside of the wall layers forming a lap at least 12, and preferably 24 in.

Protecting the Waterproofing Membrane. After installing the membrane, it must be protected against any mechanical injury which is liable to occur on backfilling with earth, depositing concrete, or brick-ing in; also against sagging, bulging, or running, when subjected to intense summer heat. The following means are adopted for this purpose:

(1) On walls it is customary to protect the membrane with brickwork, or a facing of 1 : 3½ Portland-cement mortar $\frac{3}{8}$ to $\frac{1}{2}$ in. thick.

(2) On flat surfaces, the membrane is covered with concrete or bricks embedded in cement grout or a bituminous joint-filler (p. 382).

(3) Where the membrane is laid on level floors of railroad bridges, very good results have been obtained by covering it with a 1½-in. layer of asphalt mastic flooring (p. 374) separated from the membrane by a course of asphalt-saturated asbestos felt.

Table XXXIII gives a résumé of the damp-proofing and waterproofing methods applicable under different conditions to various structures.

INSULATING AND SHEATHING PAPERS

Insulating and sheathing papers are manufactured from special paper stock waterproofed with bituminous mixtures in one of three different ways, and according to which the following classes are recognized, viz.:

(1) Paper coated but not saturated.

(2) Paper saturated but not coated.

(3) Paper both saturated and coated with bituminous compositions.

The function of the insulating or sheathing paper is to prevent the transfer of heat from the outside to the inside of a closed chamber or building. Expressed in another way, its purpose is to keep the inside either cooler or warmer than the surrounding atmosphere. In the case of cold-storage plants, railroad refrigerator cars, ice chests or vaults, insulating papers are used to keep the interior *cool*; whereas with buildings and residences heated artificially in winter, the function of the building or sheathing paper is to keep the interior *warm*, by preventing the egress of heat.

Insulating and sheathing papers are used to line walls, floors, and sometimes ceilings in one or more layers. The greater the number of layers used, the more efficient the installation. For buildings and residences, usually one layer of the paper is employed, whereas for cold-

TABLE XXXIII
DESCRIPTION OF WATERPROOFING AND DAMP-PROOFING METHODS*

No.	Materials Employed.	Method of Use.	Thickness.	Remarks
<i>Surface coatings:</i>				
A	Clear damp-proofing paints.	Brushed cold on exterior surfaces.	2 coats.	} For damp-proofing new or old work above ground; also to preserve building stone and prevent efflorescence.
B	Paraffine melted and applied hot.	Brushed hot on exterior surfaces previously warmed.	Penetrates $\frac{1}{8}$ to $\frac{1}{2}$ in.	
C	Black damp-proofing paints.	Brushed cold on interior surfaces.	2 coats.	Used to replace furring and lathing.
D	Bituminous cements.	Trowelled cold on exterior or interior surfaces.	1 coat, $\frac{1}{16}$ to $\frac{1}{8}$ in thick.	Used for same purposes as black damp-proofing paints, also to a limited extent on outside of walls.
E	Bituminous adhesive compounds.	Mopped hot on exterior surfaces.	1 mopping, $\frac{1}{16}$ to $\frac{1}{8}$ in. thick.	Used on outside of walls where conditions are not severe.
<i>Integral methods:</i>				
F	Cement-mortar with waterproofing compound.	As a facing on interior surfaces exposed to moderate or great heads of water; also as a stucco on exterior walls.	$\frac{3}{4}$ to 1 in. on floors; $\frac{1}{2}$ to $\frac{3}{4}$ in. on walls.	Used as facings on new work or to remedy defective old work; also as stucco on new work.
G	Carefully graded concrete with waterproofing compound.	Mixed in the body or mass of the concrete when formed.	Throughout the concrete.	Suitable only for new work in the course of construction.
<i>Membrane method:</i>				
H	Bituminized fabrics employed in conjunction with bituminous adhesive compounds.	In alternate layers on exterior surfaces exposed to a head of water.	2 to 10 layers.	Suitable only for subgrade work in the course of construction.
<i>Plastic method:</i>				
I	Asphalt mastic.	As a plaster or coating on surfaces exposed to moderate heads of water.	$\frac{1}{4}$ to 1 in. thick.	Gives the best results on horizontal surfaces in new or old work; difficult to apply on vertical surfaces.
<i>Membrane and plastic method:</i>				
J	Bituminized fabrics employed in conjunction with asphalt mastic.	In alternate layers on surfaces exposed to moderate or great heads of water.	2 to 5 layers of fabric with a total of $\frac{1}{4}$ to 1 in. of mastic.	Suitable only for new work. Capable of withstanding vibration.

* *Waterproofing* is intended to prevent the ingress or egress of water existing under pressure; *damp-proofing* is intended to resist the ingress of moisture in places where it cannot accumulate under pressure.

storage plants, refrigerator cars, and ice chests it is customary to use two or more layers of the paper with air spaces in between. The least expensive and most efficient form of insulation consists in confining

TABLE XXXIII.—Continued.
METHODS SUITABLE FOR VARIOUS STRUCTURES

Nature of Work.	During Construction (New Work).	After Construction (Old Work).	Remarks.	
<i>Buildings:</i>				
Exposed walls	On inside.....	C, D	C, D	For damp-proofing walls and replacing furring and lathing.
	On outside.....	A, B	A, B	For damp-proofing and preserving stone and to prevent efflorescence.
	On outside.....	F	A	For waterproofing stucco and preventing cracks.
	On outside.....	D, E	D, E	For damp-proofing where appearance is immaterial.
Superstructural floors (in bath-rooms, toilets, laboratories, stables, garages, etc.), swimming pools and tanks indoors.	F, H, I	F, I	For preventing seepage or else to retain water.	
Foundation pits, wells, trenches, footings, basement walls and floors.	F, H	F	For resisting external water pressure.	
Concrete blocks.....	A, F	A	For damp-proofing and preventing cracks.	
<i>Railroad structures:</i>				
Subways, tunnels, arches, culverts and retaining walls.	F, G, H	F	For resisting water pressure or preventing seepage, and in certain cases to withstand vibration (except F). Great skill required to waterproof <i>after</i> construction.	
Bridges.....	H, I, J	F		
<i>Water and sewage systems:</i>				
Reservoirs.....	F, G, H, I	F, I	For resisting water pressure. Mastic (I) difficult to instal when masonry once saturated with water.	
Dams, conduits, filtering chambers, aqueducts, sewage disposal systems and manholes.	E, F, G	F	For preventing seepage of water or sewage through masonry.	
<i>Marine work:</i>				
Concrete piles, piers, sea walls, and cement ships.	F, G	F	For protection against frost and the destructive action of sea water.	

a "dead" or non-circulating air space between two or more layers of insulating paper.

In practice, the paper is introduced in the floors, walls and partitions of buildings between protective layers of wooden boards. In other cases, the insulation is manufactured in the form of flat sheets composed of vegetable or animal fibres (e.g., flax, hair, etc.) sewn or otherwise fastened between two layers of bituminized paper, and known to the trade as "flax felt," "hair felt," etc.

Untreated paper answers poorly for insulating purposes, as it will

become affected by the moisture and dampness resulting from the condensation which occurs whenever a cool surface comes in contact with warmer air carrying a larger percentage of moisture. Under the influence of moisture, raw paper soon disintegrates and loses its value as an insulator. It is necessary, therefore, to waterproof the raw paper to enable it to satisfactorily resist decay. Asphaltic materials and waxes are ordinarily employed for this purpose.

Raw Paper Stock. A strong paper of open texture should be used for manufacturing insulating and sheathing papers. In accordance with the paper-makers' scale the raw stock is designated by a "number," corresponding to the weight in pounds per ream composed of 500 sheets, each measuring 2 by 3 ft.; in other words, by the weight in pounds of 3000 sq.ft. Raw papers from No. 30 to No. 180 are used, composed of one or more of the following classes of fibres, viz.:

- (1) Jute, hemp and manila fibres.
- (2) Chemical wood fibres (sulphite and sulphate fibres).
- (3) Mechanical wood fibres (i.e., ground wood).
- (4) Rag fibres (cotton and wool).

The first three classes are ordinarily used, and rag fibres in rare cases to open up the "texture" of the sheet, and enable it to saturate more readily.¹ Rags serve to increase the "thickness factor" and correspondingly decrease the "strength factor" of the paper.

Jute, hemp and manila fibres impart toughness, strength and permanence to the paper. Chemical wood fibres also tend to strengthen the paper, but are not regarded with as much favor as the foregoing, since it is difficult and in some cases impossible to remove the last traces of chemicals, which in time are apt to decompose and weaken the paper. Chemical wood fibres are divided into two classes, viz.: sulphite and sulphate fibres respectively (p. 568). The sulphate fibres are present in "kraft" papers, and represent one of the strongest of all fibres. Mechanical wood fibres are the first to "rot" and decrease in strength, and their proportion should therefore be kept as low as possible.

In ascertaining the value of the raw paper for insulating and sheathing purposes, preference should be given to stock carrying the smallest percentage of mechanical wood. It is advisable that this should not exceed 25 per cent of the total. The balance may consist of jute, hemp, manila and chemical wood fibres in varying proportions, or chemical wood fibres alone. A good kraft paper will consist of 100 per cent chemical wood (sulphate) fibres.

The paper should be loose in texture, showing a thickness factor of 0.090 to 0.125 (p. 569), a strength factor (ascertained by the Mullen tester, p. 390) ranging from 0.35 to 1.00 (averaging about 0.60), and not exceeding 3 per cent ash on ignition. The highest strength factors are shown by kraft papers which are sometimes guaranteed to test a pound on the Mullen tester, for each pound in weight on the paper-makers' scale.

¹ The addition of rag fibres rarely exceeds 25 per cent by weight.

Bituminous Saturations. For saturating the paper, the bituminous composition may consist of the following:

(1) Dark-colored mixtures similar to those used for saturating prepared roofings (p. 391).

(2) Light-colored mixtures containing one or more of the following products: paraffine wax, petrolatum, viscous cylinder oils and wax tailings.

Bituminous Coating Compositions. Dark-colored asphaltic mixtures are used, similar to the coatings of prepared roofings (p. 392), with the exception that they are usually manufactured harder in consistency and of a higher fusing-point. A small percentage of mineral, animal or vegetable wax (5 to 15 per cent) is sometimes added to impart wax-like properties and an "unctuous" feel.¹ Residual asphalts have also been patented for coating purposes.²

Method of Manufacture. The raw paper is saturated, coated, or both saturated and coated by a machine similar to that used for manufacturing prepared roofings (p. 405). The web is saturated by running it through a tank of melted saturating material, usually heated by steam to a temperature of 225 to 350° F. As paper stock is considerably denser than roofing felt (the thickness factor amounting to $\frac{1}{7}$ to $\frac{1}{8}$ of the latter) it will carry a correspondingly smaller percentage by weight of saturation. A well-saturated paper should contain not less than 33 $\frac{1}{3}$ per cent of bituminous saturation based on its finished weight. The greater the percentage of saturation present, the more moisture-resistant will the paper be. In rare cases the saturated paper will carry as high as 50 per cent by weight of bituminous saturation.

‡ The coating is applied to the paper thinner than in the case of prepared roofings. It will range from 10 to 25 lb per 1000 sq.ft. (referring to the coating on *both* sides of the sheet), when applied to saturated papers, with an increase of about 25 per cent for papers which are coated but not saturated.

Insulating and sheathing papers are sold in rolls containing 1000, 500 and in some cases 250 sq.ft. There are no standard weights recognized by the trade, each manufacturer following his own views. Papers are marketed at the present time from 20-125 lb. per 1000 sq.ft., the heavy weights falling on the border-line between papers and "felts," often containing a proportion of rag stock.

Efficiency of the Paper .The efficiency of the finished product is dependent upon the following features:

- (1) Weight per unit area.
- (2) Mullen strength at 77° F.
- (3) Resistance to moisture.

¹ U. S. Pat. 426,633 of Apr. 29, 1880 to H. J. Bird.

² U. S. Pat. 378,520 of Feb. 28, 1888, T. J. Pearce and M. W. Beardsley.

It is a peculiar fact that the tensile strength of the paper will gradually increase after manufacture at first rapidly and then more slowly as the paper seasons. Saturated and coated papers are more waterproof, more durable and better insulators than the other types. Similarly, a paper which is saturated is more efficient than one which is simply coated. The several methods of waterproofing are designed to meet the prevailing views of engineers, some preferring one and some another. Sometimes the purpose for which the paper is to be employed will predetermine the type used; for example, for surfacing sheets of fibrous material (flax-felt or hair-felt), saturated papers only can be employed, since coated papers would gum up the needle of the machine used for sewing the sheets together.

The moisture-resistant properties of an insulating paper may be ascertained by weighing and finding the Mullen strength of a sheet of predetermined area before and after immersion in water for forty-eight hours. A square foot of the paper is ordinarily employed for this purpose. Well-known brands of paper tested by the author showed the following results:

	Saturated Only.	Saturated Only.	Saturated and Coated.	Saturated and Coated.	Saturated and Coated.
<i>Originally:</i>	<i>A</i>	<i>B</i>	<i>C</i>	<i>D</i>	<i>E</i>
Pounds per 1000 sq.ft.....	82.2	78.9	43.3	61.0	101.0
Percentage of asphalt.....	45.0	23.2	55.0	53.0	52.0
Mullen strength in pounds.	58.1	58.8	31.8	47.1	60.3
<i>After immersion:</i>					
Gain in weight per cent...	32.0	49.7	27.5	23.0	26.5
Loss in strength per cent..	54.7	71.7	51.5	54.0	55.5

Papers *A* and *B* originally weighed almost the same, but the gain in weight and loss in strength are very much less in *A*, due to the larger percentage of asphalt carried by the paper.

The thicker the paper, the stronger and more durable it will prove to be. However, from the standpoint of insulation it is better to use two layers of a thin paper with an air space in between, than a single layer of thick paper equal to their combined thickness.

Saturated and Coated Papers for Electrical Insulation. Sometimes papers of this construction are used for electrical insulating purposes, as for example in constructing automatic telephone switchboards for wrapping wires and cables, etc. The following tests were obtained by the author upon subjecting papers of this character to an alternating current increased at the rate of 125 volts per minute between flat disc terminals with rounded edges, the areas of contact measuring exactly 1 sq.in.:

	<i>A</i>	<i>B</i>	<i>C</i>	<i>D</i>
Weight in pounds per 1000 sq.ft.....	21	42	60	90
Thickness in mils.....	5	8	12	20
Mullen strength at 77° F.....	25.0	30.0	40.2	72.2
Breakdown voltage at 77° F.....	750	1190	1637	2650
Volts per mil.....	150	149	157	132

ELECTRICAL INSULATING TAPE

Bituminized tapes for electrical insulating purposes are prepared by passing strips of cotton or muslin through a bath of melted bituminous material intended to fill the pores of the fabric and provide a slight excess on the surface. They are manufactured in widths of $\frac{1}{2}$, $\frac{3}{4}$, and 1 in. respectively, and wound in $\frac{3}{8}$ to $\frac{2}{3}$ -lb. rolls, averaging $\frac{1}{2}$ lb. The length per pound varies from 62 to 72 lineal yards for $\frac{1}{2}$ -in. tape, 40 to 50 yards for $\frac{3}{4}$ -in. tape and 31 to 36 yards for 1-in. tape. The thickness will range from 0.015 to 0.025 in., averaging 0.020 in.

A sheet of cotton cloth weighing from 4 to 6 oz. per square yard is passed through a bath of melted bituminous composition, so that an excess will adhere to the surfaces (from 0.005 to 0.007 in. to *both* sides of the sheet) and after cooling, is torn into strips of the desired width and wound into rolls of predetermined weight. The weight of the product should average 1 lb. per square yard, carrying about 0.33 lb. of cotton fabric and 0.67 lb. of bituminous saturation and coating.

Characteristics of the Bituminous Impregnation. The bituminous composition with which the fabric is treated may consist of one or more of the following products:

Pure native asphalts, residual asphalts, blown petroleum asphalts, wurtzilite asphalt and fatty-acid pitch, used either singly or in various combinations when of the required consistency; or else if too hard (and the same applies also to asphaltites) fluxed to grade with one or more of the following, viz.: soft native asphalt, residual oil, soft residual asphalt, soft blown petroleum asphalt, soft fatty-acid pitch, animal and vegetable oils and fats, and wool grease.

It should comply with the following tests:

- (1) The consistency at 77° F. should be below 7.0 (Test 9c).
- (2) The susceptibility factor (Test 9b) should be as low as possible, and preferably under 25.
- (3) The ductility at 77° F. should be as high as possible, and preferably over 25 centimeters (Test 10b).
- (4) The fusing-point by the K. and S. method (Test 15a) should be between 80 and 100° F.
- (5) The volatile matter at 500° F. in four hours (Test 16a) should not exceed 5.0 per cent.
- (6) It should appear "tacky" and adhesive at room temperature, and retain this property as long as possible on exposure to air. A strip of tape hung indoors and protected from the direct rays of the sun should show no diminution in tackiness at the end of two months. This is important, for if the tape once dries out, it becomes valueless.

According to the Navy Department's specifications for insulating tape issued July 11, 1910 (No. 17-T-1) the finished product should comply with the following requirements:

The surface must be smooth, the body entirely free from holes, the edges straight without ravelling, and the width uniform. When unwinding from the original coil, there must be no tendency to leave a thread sticking to the next layer. When held before a strong light, there must be no evidence of pin holes. The cotton to be well saturated but the compound must not be put on in excess. The separation under a pull of 2 lb. per inch width applied to a coil rewound on a $\frac{1}{4}$ -in. mandrel, under a tension of 10 lb. at 75° F. shall not exceed 8 in. per minute. A strip exposed to dry heat of 210° F. for sixteen hours shall show a separation of not exceeding 3 in. per minute at 75° F. under a tension of 2 oz. per inch width, when wound in a coil on a $\frac{1}{4}$ -in. mandrel immediately after removal from the source of heat. The weight of the compound applied to the fabric shall be about 0.65 lb. per square yard. The ash on burning shall not exceed 45 per cent. The tensile strength at 75° F. shall not be less than 40 lb. per inch of width, when performed on a rubber testing machine, the initial distance between the clamps being 3 in., and the rate of separation 3 in. per minute. The dielectric strength shall not be less than 1000 volts per millimeter thickness (5 minims). No breakdown shall result between two brass balls 2 cm. in diameter, at the specified alternating potential having an effective value at a frequency of 60 cycles, applied continuously for five minutes. In making the test the electrodes must be brought close together so that the tape will just move between them. The tape shall be packed in tissue paper or tin foil and enclosed in a tin box, to prevent it from drying out.

BITUMINIZED WALL BOARD

Methods of Manufacture. Wall board is used in forming ceilings, also partitions between the rooms of dwellings. It is nailed directly to the wooden beams and takes the place of lath and plaster. Wall board is manufactured by assembling two or more layers of pulp board (manufactured from ground wood) or chip board (manufactured from waste papers), so as to form a total thickness approximating $\frac{1}{4}$ in. The individual layers of pulp or chip board measuring 0.025 to 0.060 in. are generally cemented together with silicate of soda, but in certain cases asphalt is used. The manufacturers contend that asphalt contributes to the moisture-resisting properties of the finished board, but this, however, is a mooted question. When asphalt is used, it is introduced while melted between the several layers of pulp or chip board, following substantially the same procedure as in manufacturing multiple-layered roofings (p. 410).

Each asphalt layer varies from 0.020–0.025 in. thick. Theoretically, an asphalt having a specific gravity of 1.00 at 77° F. should weigh 5.20 lb. per 1000 sq.ft. in a layer 0.001 in. thick. Actually, however, it will weigh 4.80–4.85 lb., due to the fact

that a portion of the asphalt soaks into the board on account of its porosity and slight irregularities in its surface.

Another type of bituminized wall board consists of a single layer of chip board measuring about 0.060 in. thick, surfaced on one side with a fairly heavy coating of asphalt, in which are embedded wooden lath strips, spaced at intervals.¹ This may either be used as a wall board by fastening it with the smooth side outward, or if reversed, it may be used as a plaster board, and plaster applied directly to the lath strips. Still another modification consists of wooden lath strips coated with asphalt and assembled side by side between two layers of strong paper or chip board firmly cemented in place with asphalt.²

¹ U. S. Pat. 868,157 of Aug. 15, 1907 to G. F. Bishopric.

² U. S. Pat. 206,850 of Aug. 13, 1878 to D. S. Armstrong.

CHAPTER XXVI

SEMI-LIQUID, SEMI-SOLID AND SOLID BITUMINOUS COMPOSITIONS

Adhesive Compounds for Built-up Roofing and Waterproofing Work. Tar-pitches and asphaltic products are used for this purpose, similar in composition to the surface coatings of sheet roofings (p. 392). Adhesive compounds are employed in three classes of work, viz.:

(1) For constructing membrane waterproofings on underground work exposed to uniformly moderate temperature conditions, as for example tunnels, foundations of buildings, retaining walls, etc.

(2) For constructing membrane waterproofings on structures above ground, exposed to wide fluctuations in temperature and subjected to severe vibration, as on bridges, culverts, etc.

(3) For constructing built-up roofs exposed to extremely wide fluctuations in temperature, and to little or no vibration.

Each class will be considered separately.

Adhesive Compounds for Membrane Waterproofing Underground. Since these are exposed to uniformly moderate temperature conditions, they are usually prepared of a comparatively low fusing-point. The two most important considerations are that they should have a high tensile strength and great ductility at 77° F., and it is immaterial whether or not they have a low susceptibility factor.

The proposed tentative specifications for coal-tar pitch recommended by the American Society for Testing Materials, (1917) for waterproofing under moderately uniform temperature conditions (Type A) are as follows:

(a) The fusing-point as determined by the cube method in a water bath shall be between 120-140° F. In specifying the fusing-point within the above limits, a variation of not more than 5° F. in either direction will be permitted.

(b) The penetration at 77° F. shall not be less than 20 nor more than 120.

(c) The ductility at 77° F. when a briquette having a minimum section of 1 sq.cm. is pulled apart at the rate of 5 cms. per minute, shall not be less than 40 cms.

(d) The loss of a 20-gram sample on heating five hours at 325° F. shall not exceed 9 per cent for pitch having a fusing-point between 120 and 130° F., or 7 per cent for pitch having a fusing-point between 130 and 140° F.

(e) The specific gravity at 77/77 F. shall fall within the range of 1.24 and 1.34. The specific gravity at 140/140° F. of the distillate to 671° F. shall not be less than 1.06.

(f) The matter soluble in hot toluol-benzol shall not be less than 65 or more than 85 per cent.

(g) The ash shall not exceed 1 per cent.

The proposed tentative specifications for asphalt recommended by the same Society (1917), are as follows:

(a) The fusing-point shall be between 100 and 140° F. as determined by the ball and ring method in a water bath, and shall be specified for one of the following classes: 130-140° F.; 115°-130 F.; 100-115° F.

(b) The penetration at 77° F. shall not be less than 15 nor more than 125, and shall bear the following relation to the fusing-point:

Penetration range of 50-75 for fusing-points between 130-140° F.

Penetration range of 75-100 for fusing-points between 115-130° F.

Penetration range of 100-125 for fusing-points between 100-115° F.

(c) The ductility at 77° F. shall not be less than 30 cms.

(d) The specific gravity at 77/77° F., shall not be more than 1.08.

(e) The solubility in cold carbon disulphide shall not be less than 95 per cent.

(f) The loss of a 50-gram sample on heating five hours at 325° F. shall not exceed 1 per cent, and the penetration of the residue shall not be less than 50 per cent of the original penetration.

(g) The ash shall not exceed 4 per cent.

The specifications issued by the Public Service Commission of the State of New York for asphaltic adhesive to be used in subway construction, provides for smaller ranges in the tests, viz.:

(a) Not less than 95 per cent shall be soluble in cold carbon disulphide.

(b) At least 98½ per cent of the portion soluble in cold carbon disulphide shall be soluble in cold carbon tetrachloride.

(c) The flash-point shall not be below 350° F. when tested in the New York State closed tester.

(d) When 20 grams are heated for five hours at 325° F. in a tin box 2½ in. in diameter, the loss shall not exceed 5 per cent by weight, nor shall the penetration at 77° F. after such heating be less than one-half the original penetration.

(e) The fusing-point by the K. and S. method shall be between 115 and 135° F.

(f) The penetration at 77° F. shall be between 75 and 100.

(g) The ductility at 77° F. shall not be less than 20 cms.

Adhesive Compounds for Membrane Waterproofing above Ground.

Bituminous materials used under these conditions must necessarily withstand wide variations in temperature without softening or becoming brittle. In other words, the material should have a low susceptibility factor. This will necessarily exclude tar products, and restrict the choice to the following asphaltic compositions:

(1) Asphaltites fluxed to the desired consistency with residual oil, petroleum asphalt or soft residual asphalt.

(2) Blown petroleum asphalts of the proper consistency.

No "standard" specifications have at present been proposed for this class of work, but in general the adhesive should comply with the following characteristics:

(a) The penetration. (Test 9b) shall range as follows:

At 115° F.....	100-150
At 77° F.....	50-100
At 32° F.....	25-50

(b) The susceptibility factor shall not exceed 35 (Test 9d)¹

(c) The ductility at 77° F. (Test 10a) shall not be less than 20.

(d) The fusing-point by the K. and S. method (Test 15a) should be between 125-155° F.

(e) The volatile matter at 325° F. for five hours (Test 16a) should be less than 1 per cent.

(f) The flash-point (Test 17a) should exceed 450° F.

(g) Solubility in carbon disulphide (Test 21a) to exceed 95 per cent.

(h) Solubility in 88° naphtha (Test 23) to be greater than 80 per cent.

Adhesive compounds may be safely heated to 400° F. when applied to the masonry or felt. A typical product of this group is represented by the specimen of blown petroleum asphalt derived from Mexican crude oil having a fusing-point of 143° F. (K. and S. method), included in Table XXV, facing p. 294.

Adhesive Compounds for Built-up Roofing Work. This class may either consist of coal-tar or asphaltic products as they are used in structures where there is little to no vibration. The same materials are adapted for this purpose as for the coating compounds of prepared roofings but they are generally prepared of a softer consistency and lower fusing-point. The susceptibility factor does not play an important role, and the ductility may be considerably less than in the foregoing class of adhesives. No standard specifications have been proposed for this group of products, but the author's experience dictates the following ranges:

(a) Penetration at 77° F. (Test 9b) to be between 25-75.

(b) The consistency at 77° F. (Test 9c) to be between 10 and 25.

(c) The ductility at 77° F. (Test 10a) to be not less than 10 cms.

(d) The tensile strength at 77° F. to be not less than 2.0.

(e) The fusing-point of coal-tar products by the cube method (Test 15c) to range between 145 and 175° F.

(f) The fusing-point of asphaltic products by the ball and ring method (Test 15b) to range between 160 and 190° F.

¹ The following tests have been suggested to insure sufficient pliability at low temperatures, also resistance to the heat of the sun: a prism $\frac{1}{8}$ in. \times 1 in. \times 3 in. when reduced to 0° F. in a mixture of snow and salt must remain pliable, and a 2-in. cube must not flow or become distorted when subjected to 110° F. for 10 hours.

(g) The volatile matter at 325° F. in five hours (Test 16a) shall not exceed 1 per cent, and the penetration of the residue at 77° F. to be not less than 50 per cent of the original penetration.

(h) The flash-point (Test 17a) to exceed 350° F.

(i) The solubility of asphaltic products to exceed 95 per cent in carbon disulphide (Test 21a) and 75 per cent in 88° naphtha (Test 23). The solubility of coal-tar products in hot toluol-benzol (Test 22) to range between 65 and 85 per cent.

Compounds for roofing work are usually applied at temperature of 350–400° F.

Pipe-dips and Pipe-sealing Compounds. *Pipe Dips.* To prolong the life of metal pipes, it is sometimes customary to treat them with solid bituminous compositions¹ to protect them either inside or outside or both. The treatment may consist in simply dipping the pipe in the melted compound, a combination of dipping and wrapping with a bituminized fabric or burying the entire pipe in a trough filled with bituminous matter.² Steel pipes are more susceptible to corrosion than cast-iron pipes, since the minute particles of graphitic carbon or else the molecular structure of the cast iron tends to retard its action. Pipes are prone to corrode internally when used for conveying water, including water-mains or water-supply pipes. The external corrosion is brought about by one or more of the following circumstances:

(1) Exposure to moist soil conditions.

(2) Electrolysis induced by stray electric currents.

(3) Exposure to mineral salts in the soil, as for example the "alkali" normally occurring in some of the western States.

(4) Contact with dilute acid, as for example sulphuric acid occurring in the water of coal and other mines, and derived from the sulphur present in the minerals (sulphides, sulphates, etc.).

Cast-iron pipes are rarely protected at the present time, but steel pipes are often coated, and especially when used for the following purposes, viz.: water mains, lines for conveying oil across the continent, steel flumes for irrigation or power purposes, compressed-air pipes for operating block signals or switches on railways, conduits for transmission and telephone wires, pipes for conveying illuminating or natural gas, pipes apt to come in contact with acid liquors in mines, etc.

To fulfil its function satisfactorily, a covering should be:³

(1) Impervious to air and moisture, and a non-conductor of electricity.

¹ Linseed oil and bituminous paints, p. 472, also inorganic materials such as alloys, oxides, silicates, and Portland-cement mortar or concrete are also used for this purpose.

² "Rustless Coatings" by M. P. Wood, 1st Edition, New York, 1904, Chapter XII; "The Industrial and Artistic Technology of Paint and Varnish," by A. H. Sabin, 2d Edition, New York, 1917, Chapter XVIII; Series of articles by R. B. Harper entitled "The Comparative Values of Various Coatings and Coverings for the Prevention of Soil and Electrolytic Corrosion of Iron Pipe," *Am. Gas Light J.*, **91**, 429, 475, 528, 575, 625 and 667, 1909.

³ "The Corrosion of Metals," A. H. Sexton, Manchester, England, 1905,

(2) Of such a character that should the surface be broken through, the covering will not accelerate corrosion.

(3) Not susceptible to being chipped or broken through by any treatment which the pipe may receive during its installation or use.

(4) Durable without becoming porous, brittle or cracking by the action of air, moisture or light under the conditions to which it is likely to be exposed.

(5) Incapable of producing any deterioration in the metal to which it is applied.

(6) Easy of application.

(7) Easily renewable, if the surface becomes broken or damaged by accident or otherwise.

The first compound to be used for this purpose was composed of moderately hard coal-tar pitch combined with linseed oil.¹ The pipe to be treated was brought to a temperature of 300° F., and then immersed into a bath of the pitch mixture maintained at the same temperature. The pipe upon being removed was kept at 300° F., and protected from draughts until the coating baked hard and tough. Pipes treated in this manner are said to have proven very durable.

Modern practice is very similar to that followed by Smith, but when coal-tar pitch is used the linseed oil is replaced with creosote oil (i.e., dead or anthracene oil), of which small quantities are added from time to time, to maintain the pitch at the proper fusing-point and hardness, since continuous heating would otherwise volatilize the light oils, and gradually harden the coal-tar pitch. Under the most favorable conditions, however, coal-tar pitch and creosote oil form a brittle coating which is apt to be injured and chip or scale off in time. For these reasons asphaltic compositions are being used in place of the coal-tar pitch, and generally with better results.

The most satisfactory asphaltic compounds correspond in physical properties with the adhesive compounds used for waterproofing railroad bridges (p. 443), having a low susceptibility factor, moderately high fusing-point, moderate hardness, great toughness, elasticity and adhesive properties. Residual oil is generally used to keep the asphalt fluxed to a uniform hardness and fusing-point.

The bituminous mixture is maintained at about 400° F., in a horizontal or vertical tank, well insulated to prevent radiation, and heated by coal, oil or producer gas. The sections of pipe are first placed in an oven through which is circulated a current of air heated to 400° F., then immersed into the bath of melted bituminous matter, allowed to drain in a heated chamber above the tank and finally cooled. The finished coating is 0.05-1.10 in. thick, and because of the "baking" to which it has been subjected, its fusing-point becomes a good deal higher than the compound originally placed in the tank.

The great objection to the use of a dipped coating is the ease with which it becomes injured on handling during transportation or installation. This objection may be overcome by wrapping the pipe spirally after it has been dipped with strips of bituminized fabric, such as tar- or asphalt-saturated paper, felt or cloth 0.005-0.100 in. thick (measuring 10-15 sq.ft. per pound). For wrapping 2-in. pipes, 8-in. strips are used; for 4-in. pipes, 16-in. strips; and for 8-in. pipes, 32-in. strips. The fabric may be fastened to the dipped coating by the agency of thin layer of melted bituminous composition, or the cold application of a paint composed of the composition dissolved in a volatile solvent. The pipe after being wrapped may either be marketed as such or else surfaced with another such coating. Pipes finished

¹ Eng. Pat. of 1848, No. 12,291, Oct. 19, to R. Angus Smith.

in this manner are much less susceptible to injury, and will last for many years even when subjected to severe conditions.

Pipe-sealing Compounds. Bituminous compounds have also met with considerable success for sealing the joints of metal or earthenware sewer and drain pipes. Asphaltic compounds are usually used for this purpose, carrying 50 to 65 per cent of finely divided mineral matter, preferably silica on account of its resistance to acids and other corrosive agencies.

The pipes may be assembled underground in a trench or pipe gallery, and the bituminous composition melted at a temperature of 350 to 400° F. poured into the joints, which should first be well caulked to hold the compound in place. Sometimes two or more sections of the pipe are joined together above ground, while they are maintained in a vertical position, and when the compound cools they are coupled to additional lengths below ground. This will save time, since it is easier to form the joints while in a vertical position, than when laid horizontally.

The following specifications apply to a well-known pipe-seal compound on the market:

(Test 7) Specific gravity at 77° F.....	1.50 to 1.75
(Test 9c) Consistency at 77° F.....	10 to 15
(Test 10b) Ductility at 77° F.....	Greater than 1.0
(Test 11) Tensile strength at 77° F.....	Greater than 10.0
(Test 15a) Fusing-point (K. and S. method).....	185-200° F.
(Test 16a) Volatile matter at 500° F. in 4 hrs.....	Less than 1.5%

The principal considerations are that the compound should possess a high fusing-point so as not to soften in warm weather or on coming in contact with hot water flowing through the pipe; it should be sufficiently ductile to permit the pipe settling in sections without the joints breaking open; and it should have great adherence and tensile strength to enable the line to expand or contract without tearing away the compound from the pipe.

The advantage in using bituminous compounds for sealing joints is because they will permit the pipe to settle, as it is very apt to do in a freshly filled trench, without danger of the joints opening. In addition, they prevent the roots of trees or shrubs working their way into the joints, and congesting the inside of the pipe line. Other materials used for this purpose, such as cement mortar, sulphur, etc., possess these defects.

Electrical Insulating Compounds. Bituminous compounds adapt themselves very well for electrical insulating purposes, on account of their high breakdown voltage, resistance to moisture, acids, alkalies and changes in temperature, also because they are in most cases capable of withstanding exposure to the weather.

A review of the patent literature reveals thousands of patents in the electrical industry involving the use of bituminous materials and for

hundreds of different purposes. The scope of this book will permit a brief survey of but the most important principles involved.

Semi-solid to solid bituminous compounds capable of melting under the action of heat are combined in many ways, often with the addition of other substances, including resins; rubber; animal and vegetable oils and fats; animal, vegetable and mineral waxes; mineral fillers; sulphur, etc. The electrical resistance of bituminous compounds varies from 200 to 1200 volts per mil, ascertained by subjecting a specimen at 77° F. between two spherical terminals, 2 cms. in diameter, to an alternating current of 60 cycles, the voltage being increased at the uniform speed of 600 volts per minute, until a break-down occurs.

The following figures show the volume resistivity of solid bituminous and other dielectrics, expressed in ohm-centimeters, in the order of decreasing values:¹

Special paraffine.....	Over 500 × 10 ¹⁶
Ceresin.....	Over 500 × 10 ¹⁶
Hard rubber.....	100 × 10 ¹⁶
Asphalt (medium hard).....	50 × 10 ¹⁶
Sulphur.....	100 × 10 ¹⁵
Rosin.....	50 × 10 ¹⁵
Chlorinated wax ("halowax").....	20 × 10 ¹⁵
Shellac.....	10 × 10 ¹⁵
Glass.....	8 × 10 ¹⁵
Yellow wax.....	2 × 10 ¹⁵
Mica (brown African clear).....	2 × 10 ¹⁵
Unglazed porcelain.....	3 × 10 ¹⁴
Tetrachloronaphthalene.....	50 × 10 ¹²
Mica (India ruby stained).....	50 × 10 ¹²
Paraffined mahogany.....	40 × 10 ¹²
Italian marble.....	100 × 10 ⁹
White celluloid.....	20 × 10 ⁹
Slate.....	100 × 10 ⁶

Insulation for Cotton-covered Transmission Wires. The cotton covering is either saturated with a bituminous mixture, or both saturated and coated therewith. The saturation is similar to that used for impregnating prepared roofings (p. 391). Asphaltic products of a harder consistency, corresponding to the weather-coatings of prepared roofings, are employed for coating cotton-covered wires exposed out-of-doors, such as electric light wires. Wax-like properties are often imparted to the coating by incorporating a small percentage of animal, mineral or vegetable wax. Rubber is scarcely ever used as an ingredient of out-of-door mixtures because of its inferior weather-resisting properties, but it may be used to good advantage for covering cotton-covered wires indoors, in which event the bituminous matter should properly be regarded as an adulterant of the rubber. If the bituminous matter is not present to

¹ Scientific Paper No. 234 of the Bureau of Standards, Wash., D. C., 1915, "Insulative Properties of Solid Dielectrics," by H. L. Curtis.

excess, the mixture will largely retain the physical properties of rubber, and may be vulcanized by incorporating a small percentage of sulphur.

Bare copper wires may be insulated with certain varieties of fatty-acid pitch, which are transformed into an insoluble and infusible coating by heating to a high temperature (p. 332).

Vacuum Impregnating Compounds. These are used for insulating the field and armature windings of motors and dynamos, also magnet and transformer coils. The copper wire loops are wound with muslin, or in some cases with asbestos, and then impregnated with a melted bituminous or oleo-resinous composition. The former only falls within the scope of this treatise, and includes asphaltic products composed substantially of the same materials, and having approximately the same physical properties as the surface coatings of prepared roofings (p. 392). The following characteristics are of importance:

(1) The mixture should melt to a liquid having the lowest possible viscosity (Test 8a) at the temperature at which it is maintained while impregnating the coils. Since the purpose of the compound is to penetrate the muslin wrapping of the wire, it follows that the more liquid the melted compound, the more thoroughly it will fulfil this function.

(2) The softer the compound for the prescribed fusing-point, the less it is apt to crack in service, especially as the revolving armature of a motor or dynamo is subjected to the most *extreme* conditions in regard to vibration. Should the compound crack or powder, its insulative value will be nullified, and the machine will become short-circuited and put out of commission. The mixture should preferably have a penetration of 75 to 125 at 77° F. (Test 9b). Its susceptibility factor should also be as low as possible, and under no circumstances in excess of 25 (Test 9b).

(3) The ductility at 77° F. should be as high as possible, and preferably greater than 5 (Test 10).

(4) The fusing-point by the K. and S. method (Test 15a) should exceed 180° F. This will insure the compound remaining in place when the machine heats up in service.

(5) The volatile matter should not exceed 2 per cent at 500° F. in four hours (Test 16a).

(6) The solubility in carbon disulphide (Test 21a) should exceed 99 per cent. Mineral or carbonaceous matters will interfere with the penetrating properties of the compound.

Residual oil is ordinarily used to flux the compound to its original consistency, if the hardness or fusing-point increases while maintained in the liquid condition.

The apparatus consists of two steam-heated, air-tight iron tanks, one for carrying the coils to be treated, and the other for storing the melted compound, as illustrated in Fig. 149. The coils are placed in the impregnating chamber, the heat turned on and the air exhausted by the pump within $\frac{1}{2}$ -2 in. of the barometer, which draws out all the moisture. In the meantime the compound is melted in the steam-heated liquor tank at 300° F., whereupon it is allowed to enter the vacuum chamber and subjected to a pressure of 90 lb. per square inch which forces it

throughout all parts of the coil. It is maintained under compression for one or more hours, when the valve between the tanks is opened, the compound forced back into the liquor tank, and the excess allowed to drain from the coils upon being subjected to a dry heat for half an hour, which also completes the saturation. It is claimed that coils treated by this process give better service than those insulated by varnish (see p. 478), and moreover, since they become practically solid, there is no danger of the wires slipping. The total cost of treatment is less than when varnishes are used, but to offset this, the equipment is more expensive. The units are made with impregnating and compound storage tanks measuring 108 in. diameter by 240 in. high as a maximum.

Transformer and magnet coils may be treated in the same manner, and tests made in the author's laboratory demonstrate that tightly wound coils several inches

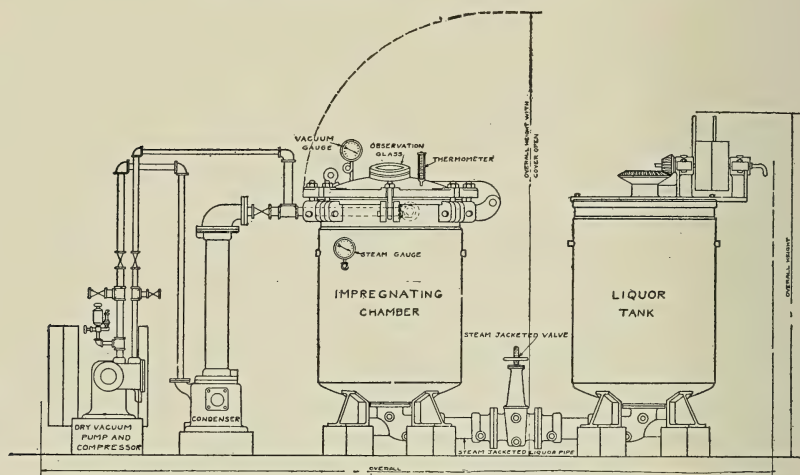

Courtesy of J. P. Devine Co.

FIG. 149.—Vacuum Impregnating Apparatus.

thick, composed of high gauge wire may be thoroughly impregnated. Bituminous compounds should only be used for air-cooled transformer coils, as they will become softened and dissolved in oil-immersion transformers. The method is now being used almost universally in large plants.

Wooden pipes for conveying liquids, wooden storage battery boxes, cotton belting, etc., may be impregnated with bituminous compositions in an apparatus of this type.

Junction-box and Pot-head Compounds. These are used for filling the metal receptacles in underground electrical transmission lines, where feeders branch off from the main wires. The connections are usually made inside of a metal box known as a "junction box" or "pot-head." Asphaltic compounds fusing in the neighborhood of 200° F. (K. and S. method, Test 15a) are melted and poured into the receptacle to her-

metically seal the wires after the junction or connection has been effected.

Battery-box Compounds. These are used for sealing "dry" batteries. After the zinc container is filled with chemicals in paste form, and the rod of carbon introduced, the top is hermetically sealed with the "battery-box compound." This consists of moderately hard coal-tar pitch (fusing at 160 to 170° F. by the cube method, Test 15c) combined with about an equal weight of siliceous filler.

"Carbons" for Batteries, Electric Lights and Armature Brushes. "Carbons" for the electrical industry are formed by heating a mixture of powdered coke and hard coal-tar pitch (fusing above 200° F. by the cube method, Test 15c), in a closed metal mould. Upon subjecting this mixture to a red heat, the coal-tar pitch carbonizes, and consolidates the particles of coke-carbon. Armature carbons are often mixed with a proportion of graphite to reduce their friction against the rapidly revolving armature; and electric light carbons with a proportion of mineral constituents (usually less than 20 per cent) including the rare earth oxides, silicates, fluorides, borates, etc., to increase the luminosity or modify the color of the electric arc.

Bituminous Rubber Substitutes. On account of the high price of pure rubber, it is often adulterated with fusible materials derived from the animal, vegetable or mineral kingdoms. Resins, animal or vegetable oils and fats, animal and vegetable waxes have been used largely for this purpose. Bituminous compounds have also found a ready use, including the following groups:

- (1) Ozokerite and paraffine wax.
- (2) Hard native asphalts.
- (3) Asphaltites either used alone or fluxed.
- (4) Blown petroleum asphalt.
- (5) Wurtzilite asphalt.
- (6) Rosin pitch.
- (7) Fatty-acid pitches.
- (8) Special products including chlorinated naphthalene, etc.

The bituminous materials are regarded mainly as "extenders," diluents or cheapeners, although in some cases they are purposely used to soften the rubber, and in others to increase its weather-resisting properties. These substitutes, known as "mineral rubber" or "factis" are incorporated with the raw rubber on the masticating rollers (consisting of heavy steel rollers revolving at unequal speeds, capable of being heated or cooled by steam or water). One method consists in first

combining the substitute with reclaimed rubber and mineral fillers on the rolls. The raw rubber is then masticated a short time, whereupon the bituminous mixture, still warm from the masticating process, is gradually worked in, small quantities at a time, and the composition finally vulcanized in the usual manner.

The most satisfactory bituminous materials for this purpose include:

(1) Products which of themselves possess "rubber-like" properties (including a certain degree of toughness, resilience, tenacity and ductility), as for example gilsonite combinations, wurtzilite asphalt, blown petroleum asphalts, and certain of the fatty-acid pitches.

(2) Bituminous substances which are capable of being hardened and toughened by the sulphur used in the vulcanization process. To this class belong the gilsonite combinations, wurtzilite asphalt and fatty-acid pitches.

According to the well-known, and often quoted experiment by Heinzerling and Pahl,¹ the use of certain bituminous materials actually *improves* the elasticity and insulative properties of the rubber when added in small percentages, although at best they tend to decrease the tensile strength.

The harder waxes and bituminous materials are used in mixtures of hard rubber (ebonite), and the softer waxes and bituminous materials in soft rubber compositions. Sometimes the bituminous product is partially vulcanized with sulphur before it is combined with the rubber, especially when too soft to be used without further treatment.

Moulding Compositions. *Mixtures for Small Moulded Articles.* Formerly shellac was extensively employed for manufacturing small moulded articles used for electrical fittings, push-buttons, knobs, handles, etc., but this is being substituted by asphalts and asphaltites owing to its scarcity and correspondingly high price.

Such mixtures are composed of three classes of materials, viz.:

(1) *Hard* native asphalts, asphaltites, or wurtzilite asphalt.

(2) Vulcanized rubber or resinous substances, including rosin (used alone or hardened by heating with lime, oxide of zinc, litharge, etc.), shellac (sometimes added in a small proportion), Manila copal, Congo copal, Kauri copal, damar, etc.

(3) Fillers which may be composed of finely divided mineral matter such as calcium carbonate, talc, silica, infusorial earth, clay, slate, carbon black, calcium sulphate or terra alba, barium sulphate or blanc fixe, etc.; fibrous mineral matter such as asbestos, mineral wool (slag wool), etc.; or fibrous vegetable matter such as wood fibres, paper fibres, rag fibres, cotton flock, etc. These may be used either singly or in various admixtures.

Innumerable combinations are used for this purpose, all of which are based upon the following general principles:

As the moulded article is usually subjected to severe usage, it is fundamentally important that the ingredients should possess great tensile strength and toughness. They should be sufficiently hard to withstand deformation under pressure, and

¹ Annals of the Society for the Advancement of Industrial Science, Berlin, 1891-2.

fuse sufficiently high not to soften in the sun or any heat to which they may be subjected in use.

The asphalts and asphaltites used should accordingly have a fusing-point not lower than 190° F., a penetration at 77° F. (Test 9c) of not exceeding 5, and a tensile strength of 77° F. of not less than 10 (Test 11). The function of the resinous matter is to enable the bituminous constituents to melt up freely, and impart gloss to the finished product. The powdered mineral matter hardens and toughens the mass, increasing its tensile strength and making it less susceptible to deformation under pressure. The fibrous matter binds the mass together and enables it to stand sharp blows without fracturing.

The constituents are combined by melting together the bituminous and resinous bodies, and then stirring in the powdered mineral matter with or without the fibres. When the mixture is uniform and while still warm and plastic, it is moulded in a suitable die and maintained under pressure while cooling. Most compositions of this character are naturally dark in color, due to the bituminous matter present and they are often darkened still further by adding a small proportion of black pigment, such as lamp-black or carbon-black. In other cases, the mass may be colored deep shades of red, brown or green by incorporating an intense pigment of the corresponding color. Light colored mixtures, however, are not obtainable.

Pre-formed Joints and Washers. A bituminous product has recently met with considerable success in glazing and sky-light construction,¹ consisting of an asphaltic cushion enveloped in sheets of asbestos, in which the panes of glass are mounted and securely bolted together, as shown in Fig. 150.

A represents a steel T-beam, protected with galvanizing or other rust-proofing. The condensation-gutter is composed of sheet steel joined to a waterproof asbestos envelope by an asphaltic composition (p. 409). The asphaltic cushion and cap-filler *E* are encased in waterproofed asbestos, and forced together in between the two sheets of glass, forming a pliable, resilient, water-tight but firm joint, which prevents the glass from being subjected to injurious strains. The upper cushion is reinforced with a cap of asbestos-protected steel, and fastened with the bolt and nut.

The cushions *B* and *E* are composed of a fluxed asphaltite or a blown petroleum asphalt of high fusing-point (in the neighborhood of 250° F.), low susceptibility factor (under 20) and absence of brittleness (hardness at 77° F. less than 20—Test 9c), mixed with 10–15 per cent of fibrous asbestos, which binds it together in a tough and non-breakable mass. These strips are further protected by being joined to an enveloping sheet of asbestos felt, waterproofed with a vegetable drying oil or bituminous saturant, similar to that used in manufacturing prepared roofing (p. 391).

Bituminated Cork Mixtures. In Europe, sheets have been prepared for insulat-

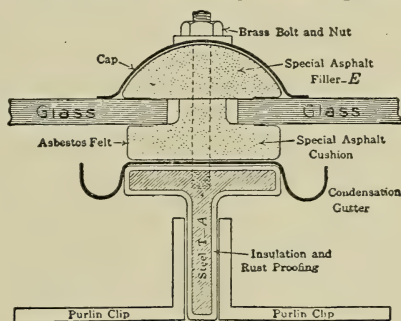

Courtesy of Asbestos Protected Metal Co.

FIG. 150.—Pre-formed Washers for Sky-lights.

¹ U. S. Pats. 1,227,861 of May 29, 1917 and 1,243,020 of Oct. 16, 1917 to W. P. Waugh.

ing rrigigerator plants, ice-chests, cold brine and ammonia pipes,¹ composed of 45 to 50 parts by weight of finely powdered cork and 100 parts of bituminous binder. The composition is prepared in a steam-heated mixing machine similar to that described on p. 351. The binder may consist of asphalt, coal-tar pitch or an aqueous emulsion of soft coal-tar pitch with colloidal clay. The mixture is pressed into various forms, such as plates, slabs or hemi-cylindrical sections suitable for covering pipes. It has a specific gravity between 0.25 and 0.40 and forms a good insulator against heat and cold.

Bituminated cork compositions are also used extensively in the United States under the name of "shoe fillers" for filling the insoles of shoes, and composed of a mixture of coarsely ground cork, with wax tailings, residual asphalts, or an emulsion of asphalt with glutinous substances.²

The mixture is trowelled between the inner and outer soles of shoes while hot and plastic, and allowed to set by cooling. It serves to insulate the bottom of the foot, and incidentally to replace the more expensive leather.

Bituminated Leather Mixtures. Shredded leather waste and asphalt have also been combined in various ways³ and proposed for various purposes, as for example covering floors, but these have only found a limited use owing to the high price of leather.

Briquette Binders. Coal-tar pitch is most generally used for briquetting coal-dust or coke-breeze. The coal or coke powder is mixed with approximately 6-8 per cent of coal-tar pitch. Two methods are in vogue, one in which the powder is mixed with a moderately soft pitch, added in the melted state, and the other, in which it is mixed cold with pulverized hard pitch. In either case, the briquettes are formed at high compression under the influence of heat.⁴ The soft coal-tar pitches have a fusing-point between 140 and 170° F. (cube method) and the hard pitches between 200 and 225° F. (cube method).⁵

Core Compounds. Coal-tar pitch is used similarly as a binder for the sand cores in forming iron and steel castings. A powdered hard pitch, fusing at 225-260° F. (cube method) is mixed with the sand and then compressed under the influence of heat, to form the cores.

Miscellaneous Bituminous Products. *Bituminous Fuels.* The non-asphaltic pyrobitumens constitute the principal source of solid fuels for combustion on a grate. Liquid bituminous fuels are also used as "fuel oil," including crude petroleum, petroleum residues, by-product tars, and distillates of little commercial value produced in refining petroleum and tar. These are atomized under the boiler with a steam jet. The tar distillates have also been successfully used in engines of the Diesel type in this country and abroad. A detailed description of the technology of fuels does not, however, fall within the scope of this treatise.

¹ U. S. Pat. 979,310 of Dec. 20, 1910 to W. C. Kammerer; German Pats. 68,532 of 1891; 122,803 of Sept. 29, 1900; 128,231 of 1902; Köhler & Graefe, *Loc. cit.*, p. 368.

² U. S. Pats. 391,265 of Aug. 25, 1891 to S. H. Howland; 808,224 and 808,227 of Dec. 26, 1905 to W. B. Arnold; 832,002 of Sept. 25, 1906; 855,868 of June 4, 1907; 861,555 of July 30, 1907; 945,294 of Jan. 4, 1910; 1,032,312 of July 9, 1912; 1,036,931 of Aug. 27, 1912; 1,115,988 of Nov. 3, 1914; 1,118,161 of Nov. 24, 1914; 1,121,054 of Dec. 15, 1914; 1,121,688 of Dec. 22, 1914; 1,121,689 of Dec. 22, 1914; 1,134,931 of Apr. 6, 1915; 1,137,679 of Apr. 27, 1915 and 1,227,502 of May 22, 1917, all to Andrew Thoma; 1,258,272 of Mar. 5, 1918 to H. S. Tirrell

³ Ger. Pats. 293,871 of Sept. 1, 1914 and 294,050 of Feb. 13, 1916, both to W. Reiner.

⁴ Rudolf Terhaerst, *J. Gasbel*, 58, 300, 1915.

⁵ "Binders for Coal Briquettes," by J. E. Mills, *Bull. 24*, Bureau of Mines, Wash., D. C., 1911; also "Fuel-Briquetting Investigations, July, 1904 to July, 1912," by C. L. Wright, *Bull. 58*, Bureau of Mines, Washington, D. C., 1913.

Tars and Oils for the Flotation of Ores. During the last few years, the flotation process has become an important factor in the concentration of certain minerals, including sulphides of copper, lead, zinc, silver, iron and other metals, also pure gold, gold telluride, native silver and native copper. The best results are obtained with sulphide ores. Oxide ores are not amenable to it unless they are first converted into the sulphide superficially, by a preliminary treatment with sodium sulphide.

In carrying out the process, the ore is reduced to a fine powder, 50-mesh material being usually the limit of coarseness. This is then beaten into a froth or foam with water and a so-called "flotation oil," which causes the heavier ore-mineral to rise to the surface, forming a pulp with the froth, and the lighter gangue-mineral to settle out. The flotation process has accordingly been aptly termed "concentration upside down." The "pulp" when it becomes thoroughly charged with ore is drawn off, and allowed to subside quietly, whereupon the "concentrate" will settle out and the "flotation oil" decanted from the surface and used over again. The gangue upon being freed from the ore, is run to the dump, and the concentrate is smelted in the usual manner.

The flotation oils may be classified as "frothers" and "collectors," the former being largely responsible for the formation of the froth, and the latter for holding the particles of ore in suspension. The "frothers" or "frothing oils" include commercial pine-oil (obtained from a destructive distillation of coniferous woods, p. 190), crude hardwood tar or "pyroligneous acid" or "wood oil" obtained in the destructive distillation of maple, birch, beech, etc. (p. 185), turpentine, various "essential oils" (p. 37), coal-tar creosote, carbolic or "middle oil," (p. 248), etc. The "collectors" or "collecting oils" include crude petroleum, liquid residual oil (p. 283), heavy mineral oil distillates (p. 268), coke-oven tar (p. 233), water-gas tar (p. 256), etc. The frothing and collecting oils are mixed together in proportions depending upon the character, composition and nature of the ore to be treated. For a very "slimy" ore consisting of fine particles, a larger amount of collecting oil will be required, whereas for granular ores a higher proportion of frothing oil will be needed. A flotation oil extensively used consists of 95 per cent crude coal tar and 5 per cent of pine oil. Another mixture which is claimed to give good results contains: pine oil 10 per cent, coal-tar creosote 80 per cent, and coal tar 10 per cent. Others have suggested the use of: hardwood creosote 40 per cent, coal-tar creosote 50 per cent, and coal tar 10 per cent.¹ The quantity of flotation oil varies from a

¹ R. E. Gilmore and C. S. Parsons, *J. Soc. Chem. Ind.*, **37**, 97-A, 1918.

fraction of a per cent to $3\frac{1}{2}$ per cent by weight of the mineral treated. The basic U. S. patent on the flotation process calls for less than 1 per cent by weight of oil. The addition of such chemicals as caustic soda, and in some cases sulphuric acid or other agents, seems to increase the efficiency of the flotation oil and to decrease the time of treatment.

The frother systems may be classified into the mechanical, pneumatic and vacuum. In the mechanical process air is beaten into the mass; in the pneumatic method bubbles of compressed air or other gas are blown into the mixture; in the vacuum system the water is first charged with gas at atmospheric pressure and bubbles released by subjecting the mixture to reduced pressure. Mechanical froths are more permanent than those produced by pneumatic means, but the former effect a cleaner separation of coarse mineral particles, whereas the latter are better adapted for slimes. Increasing the quantity of air-bubbles in the pulp, permits using less "flotation oil," also a more viscous oil, derived for example from gas-works coal tar.

In general, the following considerations should be carefully observed:¹

- (1) The pulp should be made as thick as possible.
- (2) The proportion of frothing oil to collecting oil should be carefully worked out. The more dilute the pulp or the finer the mineral particles the larger the proportion of frothing oil will be required.
- (3) The greater the aeration, the smaller the proportion of oil necessary.

Wood Preservatives. The method of preserving wood for structural and other purposes is similar to that already described for impregnating wooden paving blocks. Coal-tar creosote is most largely used, but zinc chloride is often employed, especially when the wood is to be subjected to moderately dry conditions. The method of impregnation is similar to that involving the use of creosote.

In 1915, the total output in the United States from 102 plants included the following:

Cross-ties for railroads.....	37,085,585 pieces
Piles.....	9,308,419 linear ft.
Poles.....	125,939 pieces
Paving blocks.....	2,936,370 sq.yds.
Construction timber.....	142,009,041 board ft.
Cross-arms.....	146,219 pieces
Miscellaneous lumber.....	13,937,509 board ft.
Total equivalent to.....	141,858,963 cu.ft.

¹"Bibliography of Recent Literature of Flotation of Ores," Bulletin 135, Bureau of Mines, Washington, D. C., 1917; "Answers to Questions on the Flotation of Ores," by O. C. Ralston, Tech. Paper 149, Bureau of Mines, Washington, D. C., 1917.

The total preservatives consumed for the foregoing included:

Creosote.....	80,859,442 gal.
Zinc chloride.....	33,269,604 lbs.
Miscellaneous.....	1,693,544 gal.

The following pounds of creosote are ordinarily used per cubic foot of wood:

Piles:	
Salt water.....	16-24 lbs.
Fresh water.....	12-16 "
Ground.....	8-12 "
Railway ties.....	5-12 "
Miscellaneous timber.....	8-16 "

When zinc chloride is used, $\frac{1}{4}$ - $\frac{3}{4}$ lb. per cubic foot is injected into the wood. There is a difference of opinion regarding the relative efficiencies of creosote and zinc chloride, but the former is less expensive, and also enables the wood to be used when subjected to moisture.

Waterproofing Compounds for Portland-cement Mortar and Concrete. The method of incorporating various substances with Portland-cement mortar or concrete in the course of their preparation is known as the "integral" system, according to which the waterproofing medium is mixed *throughout* the Portland-cement mortar or mass concrete. This term does not include the application of paints or other coatings to the *surface* of mortar or concrete after it has set.

Innumerable materials have been exploited for the integral waterproofing of Portland-cement mortar and concrete including:¹

- (1) Inert fillers such as finely divided clay, infusorial earth, fuller's earth, silica, talc, etc.
- (2) Active mineral fillers such as hydrated lime, aluminium hydroxide and other inorganic hydroxides, which undergo a chemical change during the setting of the cement.
- (3) Water-soluble mineral salts, such as calcium chloride, sodium silicate, sodium fluorosilicate.
- (4) Soap compounds including, (a) soluble soaps composed of sodium, potassium and ammonium combinations of animal or vegetable oils and fats, also resins; (b) insoluble soaps composed of calcium, magnesium, aluminium, iron, zinc, lead and other metals combined with animal or vegetable fats and oils, or resins.

(5) Bituminous materials. We are concerned with this last group only, as falling within the scope of this treatise. The bituminous mate-

¹"Tests of Damp-proofing and Waterproofing Compounds and Materials," by R. J. Wig and P. H. Bates, Technologic Paper No. 3, Bureau of Standards, Wash., D. C., Aug. 22, 1911; "Electrolytic Corrosion of Iron in Soils," by Burton McCullum and K. H. Logan, Technologic Paper No. 25, Bureau of Standards, Wash., D. C., June 12, 1913; "Modern Methods of Waterproofing," by M. H. Lewis, *Loc. cit.*; "Durability of Stucco and Plaster Construction," by R. J. Wig and J. C. Pearson, Technologic Paper No. 70, Bureau of Standards, Wash., D. C., Jan. 31, 1917.

rials may be divided into two classes, namely, those used in the pure state, and those used in an emulsified form.

Pure Bituminous Materials. Two classes of bituminous substances are included in this group, namely, liquid to semi-liquid coal-tar pitch (i.e., evaporated coal tar¹) and liquid asphalt. The latter may consist of native asphalt,² residual oil,³ semi-liquid sludge asphalt,⁴ etc. These are mixed with the aggregate after first wetting down the cement and sand in preparing Portland-cement mortar; or the cement, sand, gravel or broken stone in preparing concrete. Between 10 and 25 per cent of soft coal-tar pitch or asphalt are added, based on the weight of the dry cement used. As the pure bituminous compounds are naturally water-repellent, it requires *considerable* mixing to distribute them uniformly throughout the mortar or concrete, and especially in large-sized batches. In this connection, the author wishes to lay particular emphasis on the fact that laboratory tests should under no circumstances be taken as a criterion of the ease or thoroughness with which bituminous substances may be disseminated throughout the mixture. At low temperatures, both soft coal-tar pitch and liquid asphalt become almost solid, and under these circumstances it becomes *doubly* difficult to incorporate them. It has also been clearly shown that the introduction of residual oil alone materially decreases the tensile and compressive strength of mortar and concrete.⁵ Assuming, however, that with sufficient effort the mixture can be made uniform, there is no question that the resultant mortar or concrete is improved materially in its water-repellent properties.⁶

Bituminous Materials in Emulsified Form. Bituminous emulsions tend to overcome the foregoing disadvantages, as they are readily miscible with the water used for gauging the sand, cement and crushed stone. Instead of depending upon mechanical means for incorporating the pure bituminous materials with the aggregate, such as the grinding action to which it may be subjected during the process of mixing, bituminous emulsions are first brought into suspension by stirring them

¹ "Tar and Cement Pavement," by R. Grimshaw, *Mun. Eng.*, **43**, 11, 1912.

² Eng. Pat. No. 30,091 of Dec. 28, 1910, to J. Krumpelman, who treats an asphaltic shale composed of liquid asphalt carrying calcium carbonate and clay with hydrochloric acid to separate the former, and then dries the resulting powder.

³ Swiss Pat. 44,284 of Dec. 28, 1907, also Austrian Pat. 33,262 of June 10, 1908, both to Dr. Gottfried Schruf; U. S. Pat. 1,000,545 of Aug. 15, 1911 to L. W. Page.

⁴ U. S. Pat. 1,077,689 of Nov. 4, 1913 to Carleton Ellis, who describes the use of sludge asphalt neutralized with lime and mixed with fuller's earth or the like.

⁵ "Some Experiments with Mortars and Concrete with Asphaltic Oils," by Arthur Taylor and Thomas Sanborn, *Proc. Am. Soc. Civil Eng.*, **39**, 355, 1913.

⁶ "Oil-Mixed Portland Cement Concrete," by L. W. Page, Bull. No. 46, Office of Public Roads, Wash., D. C., Aug. 8, 1912; Bull. No. 230, Office of Public Roads, U. S. Dept. of Agr., Wash., D. C., July 14, 1915.

into the gauging water, which then mixes readily with the aggregate, requiring little to no effort, even at low temperatures.

The efficiency of the bituminous emulsion depends largely upon two factors, viz.: (1) the proportion of bituminous matter carried by the emulsion, and (2) whether or not its addition will interfere with the tensile or compressive strength of the cement mixture when set.

Three classes of emulsifying agents are in use, including plastic clay, a mixture of sodium silicate with barium peroxide, and inorganic hydroxides. These will be considered separately.

(1) Plastic clay is used either for emulsifying coal tar or soft coal-tar pitch,¹ also non-volatile liquid to semi-liquid asphalt, which may either be native or derived from petroleum.² Clay is first made into a paste with water, and then mixed with the asphalt either in the cold or heated state. Forty parts of dry clay will combine with 10 parts of the asphalt, requiring approximately 50 parts of water to convert it into an emulsified state. The finished mixture will accordingly carry but 10 per cent by weight of the active waterproofing constituent, namely the asphalt, the clay merely acting as an inert filler.

(2) Emulsions prepared from a cut-back coal-tar pitch of soft consistency combined with sodium carbonate, sodium silicate and barium peroxide.³ These are formed in the following manner:

Coal tar pitch.....	16.15%
Cut-back with heavy coal-tar oils.....	48.50%
Mixed with calcined sodium carbonate.....	1.95%
Water added.....	4.05%
Sodium silicate (30° Baumé).....	27.50%
Finally add to the mixture: barium peroxide.....	1.85%
Total.....	100.00%

This mixture contains a large per cent of the active waterproofing constituent, but from the author's experience sodium silicate has a decided tendency to delay the setting and reduce the strength of Portland-cement mixtures.

(3) Emulsions prepared by means of inorganic hydroxides capable of forming a plastic mixture with water,⁴ as for example calcium, iron and aluminium hydroxides have given very successful results. Residual oils of definite characteristics, soft coal-tar pitches or evaporated coal tar may be used, and ground up into a paste with a "fat" lime slaked with water. The finished paste is composed of:

Anhydrous calcium oxide.....	21.5%
Bituminous matter.....	38.5%
Water.....	40.0%
Total.....	100.0%

¹ Ger. Pat. 68,532 of July 1, 1891 to Grünzweig and Hartmann; F. Raschig, *Chem. Rev. Fett-Harz-Ind.*, **17**, 169, 1910.

² Ger. Pat. 211,877 of Sept. 5, 1906, also Eng. Pat. No. 15,100 of July 16, 1908, both to Julius Kathe.

³ U. S. Pat. 903,287 of Nov. 10, 1908 to H. V. D. Heide; Ger. Pat. 103,733 of May 6, 1899; also German application 27,653, 80-b, of Apr. 29, 1907 to Hans Wunner.

⁴ U. S. Pat. 1,134,573 of Apr. 6, 1915 to Herbert Abraham and H. W. Haines.

The emulsion contains a large proportion of the active bituminous constituent, mixes readily with the gauging water, and may be used in extraordinarily large proportions (20-30 per cent of the weight of cement used) without interfering with the set and at the same time *increasing* the tensile and compressive strengths of Portland-cement mixtures at least 5-15 per cent. This composition has been marketed extensively and gives excellent results in practice. The manufacturers recommend 2-12 lbs. of the paste per bag of Portland cement for preparing stucco and waterproof-mortar facings, and 1-2 lbs. for Portland-cement concrete. This represents the *only* bituminous waterproofing preparation known to the author which can be used under all conditions, insuring a *uniform* distribution throughout the Portland-cement mixture regardless of the temperature or the means used for preparing the mixture. At the same time it may be added in sufficient quantities to secure *absolute* waterproof properties without detracting from the strength of the structure.

Methods of Use. The integral method differs from the membrane method in that it may be used for waterproofing buildings in the course of erection, as well as for repairing the *inner* surfaces of leaky masonry already constructed. The membrane method on the other hand can *only* be used on structures in the course of erection, since it must necessarily be applied on the *outer* surfaces of foundation walls, to be subsequently covered by the earth fill. Similarly, the integral waterproofing may be readily repaired should by any chance leakage occur later due to settlement or other external causes, whereas it is extremely difficult, and in many cases impossible to repair membrane waterproofing, owing to its inaccessibility.

Integral waterproofing compounds are best adapted for use in a relatively thin layer or "facing" of Portland-cement mortar, and are much more reliable when used in this manner than when incorporated throughout the body of Portland-cement concrete, for the reason that it is a comparatively simple matter to apply a layer or facing without danger of leakage at the joinings, which is not the case with mass concrete construction.

In applying cement-mortar facings waterproofed with integral compounds, it is important to secure a firm bond with the underlying masonry. The old surface should accordingly be firm, rough, clean and wet. If the old surface is too smooth, it should be roughened by chipping; it may be cleaned by scrubbing with stiff brushes, supplemented, if necessary, by washing with muriatic acid; and it should be thoroughly wet down with a hose until it has taken up as much water as possible. The waterproof facing should be trowelled on with pressure in two or more coats. If possible, these coats should be made *continuous* and applied without interruption to avoid joints. If this is not feasible, the day's work should be finished with a bevelled edge which should be roughened or chipped to secure a bond or "key" where the connection is made on the following day. The first coat should be

"scratched" before hardening, and the second coat applied just after the first one reaches its final set. The last coat should be trowelled hard and floated.

Stucco should be $\frac{1}{2}$ – $\frac{3}{4}$ in. thick, trowelled in two coats. Waterproof-mortar facings used on waterproofing below grade, tanks and swimming pools should be applied to the walls in a layer $\frac{3}{4}$ in. thick, in two coats, and to the floors in a layer 1 in. thick in one coat. A 1 : 3 mortar should be used on all exposed work and a 1 : 2 mortar on all work protected from the direct action of the weather. The facing should be sprinkled with water until it has set hard. Great care should be taken to prevent it from drying out prematurely. Interior angles where two walls or where the walls and floor meet, should be finished with a rounded surface. By proper manipulation, waterproof facings may be applied to old leaky masonry surfaces against existing water pressure, which cannot be effectively waterproofed by any other means at present known.

Bituminous emulsions give better results than any other integral waterproofing compounds. Saponifiable oils or fats and soaps (both soluble and insoluble) weaken the cement mortar or concrete, and are not nearly as permanent on exposure to the weather, or capable of continuously resisting the action of moisture.

CHAPTER XXVII

BITUMINOUS PAINTS, CEMENTS, VARNISHES, ENAMELS AND JAPANS

THIS chapter will embrace mixtures of bituminous materials with volatile solvents, ranging from pastes to liquids. Bituminous cements are manufactured in paste form, whereas bituminous paints, varnishes, enamels and japans are prepared in the liquid state, their respective consistencies being regulated by the amount of volatile solvent incorporated.

BITUMINOUS PAINTS

Bituminous paints are composed of a bituminous base, a volatile solvent, with or without the addition of vegetable drying oils, resins, mineral fillers and pigments, and are intended to dry or set by the spontaneous evaporation of the solvent. If any vegetable drying oil is present it will contribute little, if at all, to the drying of the paint, although it will undoubtedly exert a "toughening" effect on the coating, which will become more pronounced in time. These paints are known generally as "solvent paints." The distinguishing characteristic between a bituminous paint and a bituminous varnish is that the former will set to a firm coat upon the evaporation of the solvent, whereas the hardening of the latter is contributed largely by the oxidation of the vegetable drying oil, which is present in the base in substantial proportions.

Nature of the Base Used. Bituminous paints may be divided into four groups, depending upon the composition of the solid ingredients present in the base, viz.:

Group 1. Bases containing a bituminous substance, with or without a mineral filler. The bituminous substances may include: native asphalts, asphaltites, asphaltic petroleums, residual oil, blown petroleum asphalt, residual asphalt, sludge asphalt, wurtzilite asphalt, wax tailings, mineral waxes, tars, wood-tar pitch, rosin pitch, peat- and lignite-tar pitches, water-gas-tar pitch, oil-gas-tar pitch, coal-tar pitch, fatty-acid pitch and bone-tar pitch.

Group 2. Bases containing in addition to bituminous substances, a resin (rosin, rosin esters, damar or sandarac); with or without a mineral filler; with or without a colored pigment.

Group 3. Bases containing in addition to bituminous substances, animal or vegetable oils or fats; with or without a mineral filler; with or without a colored pigment. The animal or vegetable oils or fats may include: linseed oil, china-wood oil, soya-bean oil, fish oil, cotton-seed oil, corn oil, perilla oil, lard oil, mutton fat, stearic acid, oleic acid, etc. The oils may be used either in the raw state or combined with "dryers" (see p. 475), or they may be "bodied" by heating to a high temperature, until they thicken by polymerization.

Group 4. Bases containing in addition to bituminous substances, resins in combination with animal or vegetable oils or fats; with or without a mineral filler; with or without a colored pigment. The "resins" may include: common rosin, rosin esters, the damars (including Borneo damar), sandarac, Kauri copal, Congo copal, pontianak copal and Manila copal.

The following ingredients are rarely included, viz.: rubber, wool grease, rosin oil, insoluble metal soaps, etc.

Among the resins: rosin, rosin esters, the damars and sandarac will readily combine with the bituminous constituents, either by dissolving all of them directly in the cold solvent, or by first fluxing them together with heat, and cutting them in the solvent afterwards. Fossil resins (copals) will not amalgamate directly with the bituminous constituents. They must be melted at a high temperature, and first combined with the animal or vegetable oil, whereupon the resulting oleo-resinous varnish will flux with the bituminous constituents, either in the cold, or upon melting them together. A description of the process for manufacturing oleo-resinous varnishes does not fall within the scope of this treatise.

Since the addition of "vegetable or animal oils or fats" improves the weather-resistance of bituminous substances, they should accordingly be added wherever possible in the role of "flux." The harder the bituminous substance in its raw state, and the higher its fusing-point, the larger can be the percentage of the animal or vegetable oils or fats incorporated. Rosin, the damars, sandarac or rubber, do not add to the weather-resistance of the bituminous materials, as these are of themselves deficient in this respect. They will either serve to lighten the color of bituminous materials when combined with colored pigments, or in other cases to bring about a more perfect union of the constituents, but in either event they should be confined to indoor use. On the other hand, fossil resins are highly weather-resistant, being equivalent to the asphaltites in this respect. They may accordingly be embodied in bituminous paints intended for outdoor use. Paints containing fossil resins may be made to carry a large percentage of animal or vegetable oils or fats, and will accordingly produce brighter colors with pigments, than when oils or fats are used alone.

The foregoing products may be blended together so the base will be soft, medium or hard, with a proportionate range in fusing-point. A base which is naturally soft, may be hardened by adding a suitable quantity of mineral filler or pigment. Where the base is allowed to remain soft, the paint will be limited in usefulness, and adapted only to the painting of *porous* surfaces such as masonry or dried-out composition roofings, which will give it an opportunity of soaking into the pores, and thus mask the soft properties of the coating.

Nature of the Fillers and Pigments Used. All sorts of mineral fillers (p. 393) have been suggested in connection with bituminous paints, for use either alone or in combination with colored pigments. Their function is to harden the base or to cheapen the paint. The fillers should be powdered very finely (so they will pass a

200-mesh sieve), otherwise they will tend to settle out. The more finely they are powdered and the lower their specific gravity, the longer will they remain in suspension.

The colored pigments include the metal oxides (red oxide of iron, yellow ochre, chromium oxide, etc.), chrome yellow, chrome green (composed of chrome yellow mixed with Prussian blue), graphite, etc. Where the color of the finished paint plays an important factor, *intense* pigments should be employed, as these will be required to overcome the dark color of the base. Whites are rarely employed, but will produce shades of buff and tan. Should free acids be present in the binder, as would be the case if fatty-acid pitch, bone-tar pitch, rosin or rosin pitch were used, the range of pigments is narrowed down to certain metal oxides. Pigments such as chrome green, chrome yellow, zinc oxide, etc., will combine with the free acids and form insoluble compounds, causing the paint to solidify, otherwise termed "gelatinizing" or "livering."

Nature of the Solvents Used. The solvents ordinarily used for manufacturing bituminous paints may be divided into four groups, viz.:

(1) Petroleum products, including gasolene, naphtha (benzine) and kerosene are most largely used. Among the naphthas there is a series of products boiling within a small temperature range, termed "close-cut distillates," and sold as turpentine substitutes. The gasolenes have the lowest flash- and boiling-points and the poorest solvent power, whereas the kerosenes have a higher flash- and boiling-point and a correspondingly greater solvent action, the naphthas falling in between the two. The petroleum solvents and their characteristics are included in the following table:

Solvent.	Distillation Range.	Specific Gravity at 15.5° C.	Flash-point ° F. (Abel-Pensky Closed Tester).
Gasolenes:			
Cymogene, rhigolene, etc.....	Approximately 90% at 70° C.	0.600-0.650	About -70
Canadol.....	Approximately 90% at 85° C.	0.625-0.675	About -40
Petroleum spirits.....	Approximately 90% at 100° C.	0.650-0.725	About -30
Naphthas:			
Light benzine (71-62° Bé.).....	Approximately 90% at 125° C.	0.700-0.730	-15 to +10
V. M. and P. naphtha (64-55° Bé.)....	Approximately 90% at 150° C.	0.725-0.760	-5 to +30
Turps. substitute (56-51° Bé.).....	Approximately 90% at 175° C.	0.755-0.775	} 80-105
Turps. substitute (52-48° Bé.).....	Approximately 90% at 225° C.	0.720-0.790	
Kerosenes:			
Illuminating oil (51-35° Bé.).....	Approximately 90% at 300° C.	0.775-0.850	100-120
Gas or fuel oils:			
Commercial grades.....	Approximately 90% at 400° C.	0.825-0.900	150-225

(2) Coal tar distillates, including benzol, toluol, solvent naphtha and heavy naphtha. These evaporate in the orders mentioned, their properties being set forth in the following table¹:

¹ Barrett Company, with additions.

Solvent.	Color.	Distillation Range.	Specific Gravity at 15.5° C.	Flash-point °F. (Abel-Pensky Closed Tester).
Pure benzol*.....	Water white	100% within 2° C.	.875 to .885	-10
100% benzol.....	Water white	{ Approximately and at least 100% at 100° C. }	.875 to .885	-8
90% benzol.....	Water white	{ Approximately and at least 90% at 100° C. }	.870 to .882	-5
50% benzol.....	Water white	{ Approximately and at least 50% at 100° C. Approximately and at least 90% at 120° C. }	.868 to .880	+23
Straw-colored benzol..	Straw	At least 80% at 100° C.	.862 to .882	About 30
Pure toluol.....	Water white	100% within 2° C. { Not over 5% at 100° C. }	.864 to .874	+7
Commercial toluol....	Water white	{ Approximately and at least 90% at 120° C. }	.864 to .874	About 15
Straw-colored toluol..	Straw	At least 80% at 120° C.	.862 to .872	About 17
Pure xylol.....	Water white	100% between 135° and 145° C. { Not over 5% at 130° C. }	.860 to .870	About 85
Solvent naphtha.	Water white	{ Approximately and at least 90% at 160° C. }	.862 to .872	About 78
Crude solvent naphtha	Dark straw	At least 80% at 160° C.	.862 to .882	About 78
High-flash naphtha....	Water white	100% between 150° and 200° C.	.870 to .880	Not below 100
Crude heavy solvent naphtha.....	Amber to red	{ Not over 10% at 160° C. } { At least 90% at 200° C. }	.940 to .986	Not below 90
Heavy naphtha.	Deep amber to dark red	{ Not over 10% at 160° C. } { About 70% at 200° C. }	.925 to .950	About 109

* Pure benzol should crystallize at approximately 5° C.

(3) Solvents derived from wood, including pure spirits of turpentine, wood turpentine, rosin spirits, light wood oil, wood creosote oil, pine oil, acetone oil, etc. (see p. 190). Their properties are shown in the following table:

Solvent.	Distillation Range Deg. C.	Specific Gravity at 15.5° C.	Flash-point ° F. (Abel-Pensky Closed Tester).
<i>From hardwoods:</i>			
Light acetone oil.....	75-160	0.825-0.830	Below 20
Heavy acetone oil.....	100-215	0.883-0.887	Below 50
Light wood oil.....	90% below 150	0.860-0.900	Below 50
Heavy wood (creosote) oil.....	90% below 400	0.930-0.980	Above 160
<i>From soft (resinous) woods:</i>			
Gum turpentine.....	95% below 170	} 0.860-0.870	105-108
Steam-distilled wood turpentine.....	50% below 170		
Destructively distilled wood turpentine	90% below 190	0.850-0.870	Below 25
Pine oil.....	190-240	0.925-0.950	130-170
Rosin spirits.....	80-200	0.900-0.940	Below 50
Rosin oil.....	225-400	0.940-0.990	220-280

(4) Manufactured chemicals, including carbon disulphide, carbon tetrachloride, di-chlor methane, etc. These evaporate very readily, the carbon disulphide being highly inflammable and the vapors explosive. Carbon tetrachloride and di-chlor methane similarly evaporate rapidly, but form non-explosive and non-inflammable solvents,¹ and may be used to raise the flash-point of other solvents susceptible to ready ignition alone.²

The properties of the chemical solvents adapted for use with bituminous substances are included in the following table:

Solvent.	Distillation Range Deg. C.	Specific Gravity at 15.5° C.	Flash-point ° F. (Abel-Pensky Closed Tester).
Carbon disulphide.....	46-47	1.265-1.272	-48
Acetone—C. P.....	56-57	0.790-0.800	} +14
Acetone—commercial.....	56-90	0.845-0.850	
Amyl acetate.....	About 140	0.876	72
Aniline.....	180-183	1.027	170
Nitrobenzol.....	208-215	1.187	194
Di-chlor methane (methylene chloride)	40-41	1.377	None
Chloroform.....	60-62	1.485-1.500	None
Carbon tetrachloride.....	75-77	1.580-1.600	None

Note.—Grain alcohol, wood alcohol, etc., cannot be used for bituminous materials, as they are deficient in solvent properties. Other solvents, including ether, chloroform, etc., possess good properties, but are not generally used on account of their high price.

The following table³ shows the comparative evaporation times of certain commercial solvents, tested by allowing 2 cms. of each material to evaporate under similar conditions from a metal surface 3½ in. square:

Carbon disulphide.....	3½ min.	Crude solvent naphtha.....	121 min.
Carbon tetrachloride.....	4½ "	High-flash naphtha.....	205 "
Pure benzol.....	10 "	Crude heavy solvent naphtha.....	290 "
100% benzol.....	13½ "	Heavy naphtha.....	303 "
90% benzol.....	14 "	Turpentine.....	142 "
Straw-colored benzol.....	18 "	Wood turpentine.....	480 "
50% benzol.....	23 "	80° gasolene.....	4 "
Pure toluol.....	29 "	70° gasolene.....	8 "
Commercial toluol.....	33 "	66° benzine.....	16 "
Straw-colored toluol.....	36 "	62° benzine.....	18 "
Xylol.....	89 "	Petroleum turps substitute (42°)...	346 "
Solvent naphtha.....	107 "	Kerosene.....	475 "

The proportion of solvent used, depends upon three factors: (1) the nature of the bituminous base, (2) the "capacity" of the solvent, and (3) the consistency of the paint desired.

In general, the higher the susceptibility of the base, the lower will be the viscosity of the resulting paint. Upon running parallel tests, with the same percentage by

¹ U. S. Pat. 835,113 of Nov. 6, 1906, to S. G. Penney.

² "Flash, Fire and Explosion Tests on Mixtures of Carbon Tetrachloride and Naphtha," by E. A. Barrier, *Jour. Ind. Eng. Chem.*, 2, 16, 1910.

³ Barrett Co. with additions.

weight in all cases of the respective solvents, it will be found that residual asphalt, sludge asphalt, wood-tar pitch, water-gas-tar pitch, oil-gas-tar pitch and the coal-tar pitches will form paints of lower viscosity than paints prepared from fluxed asphaltites, blown petroleum asphalt, wurtzilite asphalt and the non-susceptible fatty-acid pitches. With bituminous materials having a high susceptibility factor, the fusing-point of the base exerts comparatively little influence on the viscosity of the completed paint. Bases that are hard, and at the same time possess "tough and rubber-like" properties (i.e. a low susceptibility factor, considerable elasticity, resilience and tenacity) when used alone, are apt to gelatinize after they have been dissolved in the volatile solvent. In other words, although the paint when first made up may appear liquid, it will after a time become transformed into a jelly-like mass. This is particularly apt to occur with hard and "rubbery" fatty-acid pitches, wurtzilite asphalt and gilsonite. The specific gravity of the base has also a bearing on the paint's consistency. Since it is customary to measure the base and solvent by *weight*, it follows that the higher the specific gravity of the base, the smaller will be its volume for a given weight. Hence a base of high gravity will form a paint of lower viscosity than an equal weight of a low gravity base, but substantially the same in other respects.

The "capacity" of the solvent also has an important bearing upon the viscosity of the paint. The greater the solvent action of the menstruum, the smaller percentage by weight will be required to produce a paint of a given viscosity. In general, aromatic hydrocarbons are superior in solvent action to aliphatic hydrocarbons. Coal-tar products and those derived from wood distillation constitute better solvents than petroleum products. Similarly, distillates from aromatic petroleum are relatively better solvents than those produced from strictly aliphatic petroleum. In all cases the higher the molecular weight of the hydrocarbons, the better will be the solvent action. Derivatives such as carbon disulphide, carbon tetrachloride, chloroform, di-chlor methane, ether, etc., are generally better solvents than the corresponding pure hydrocarbons from which they originated. For the reason previously explained, the specific gravity of the solvent has a bearing on the consistency of the paint, from the standpoint of percentage expressed by weight.

The weight of solvent in commercial bituminous paints ranges from 20 to 80 per cent. The smaller percentages are used in heavy-bodied paints intended for coating masonry, for sealing the joints of composition roofing, and for application to porous surfaces. Light-bodied paints containing the larger percentages of solvent are used where it is desired to secure great penetration, rapid drying properties, or where the paint is used for "dipping" purposes.

Mineral waxes alone are difficultly soluble in most solvents (see p. 310). Asphaltites and asphalts dissolve in the following solvents, approximately in the order mentioned, viz.: carbon disulphide, carbon tetrachloride, distillates from coal tar, resinous woods and petroleums. Comparing products of the same fusing-point, we find that blown petroleum asphalts are most soluble, then come native asphalts, sludge asphalt, wurtzilite asphalt, and lastly the residual asphalts.

Tar pitches produced from the destructive distillation of bones, wood, peat, lignite and coal are more difficultly soluble than asphaltic materials and pitches not derived from tars (e.g., rosin pitch and fatty-acid pitch). Tar pitches dissolve most readily in the following solvents, approximately in the order mentioned, viz., carbon disulphide, coal-tar distillates and distillates from resinous woods. Of the pitches: rosin pitch, fatty-acid pitch, bone-tar pitch, peat- and lignite-tar pitches

are relatively the most soluble, and oil-gas-tar pitch, water-gas-tar pitch, wood-tar pitch and coal-tar pitch are least soluble, ranging approximately in the sequence stated. The solubility of bituminous substances may be increased by fluxing with such materials as rosin, animal and vegetable oils or fats, wax tailings, fatty-acid pitch, and in some cases residual oil derived from aromatic petroleums.

Methods of Manufacture. When all the ingredients of the base fuse at comparatively low temperatures, the simplest method consists in stirring them with the solvent in a closed steam-jacketed tank provided with an agitator. The temperature should be raised close to the boiling-point of the solvent, and the stirring continued until the solution is complete. When some of the materials melt at high temperatures it is advisable to flux them with the remaining ingredients of the base by direct fire, either in a small tank mounted on wheels, known as a "varnish kettle," heated by coke burning in a pit, on grate bars sunken 8 to 12 in. below the floor level (Fig. 151), or in a

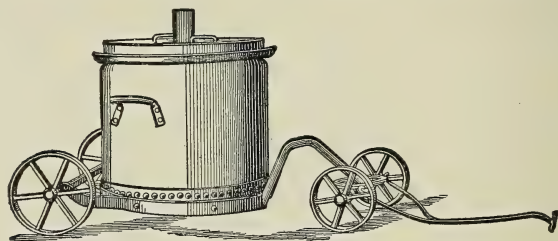
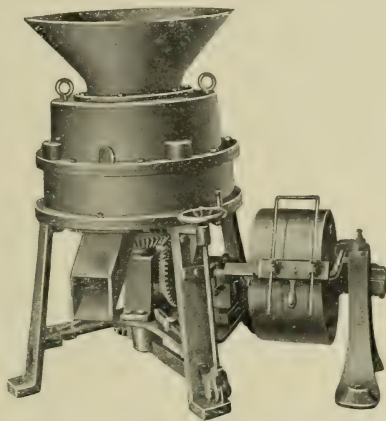

FIG. 151.—Varnish Kettle.

large stationary hemi-cylindrical melting tank (p. 69). When the melting is effected in a varnish kettle, after the ingredients have been fluxed together, it is withdrawn a safe distance from the fire, cooled to slightly under the boiling-point of the solvent, which is then gradually introduced, small quantities at a time, stirring continuously with a paddle. When the base has been melted in a stationary hemi-cylindrical kettle, it is run by gravity or pumped into a closed cylindrical tank equipped with a stirring device, and after cooling sufficiently, the solvent is run in slowly, with continuous stirring until the solution is complete. The second method is used for preparing large quantities of paint in one charge.

Sometimes the bituminous paint is mixed cold in various proportions with oleo-resinous varnishes manufactured in the usual manner, either to increase its weather-resistance or for purpose of lightening its color, when colored pigments are to be incorporated. Pigments and fillers may be mixed with the paint by simply stirring them together

in a tank provided with an agitator, or by grinding the mineral ingredients and sufficient paint to form a paste in an enclosed buhr-stone mill, as illustrated in Fig. 152, and then thinning the paste to brushing consistency with an additional quantity of bituminous paint, or in certain cases with a volatile solvent. Fillers or pigments ground in accordance with the latter procedure are less apt to settle on standing, than if simply stirred into the paint. It should be noted, however, that even under the best conditions, fillers and pigments are more apt to settle from bituminous solvent paints than from oil paints. This is probably due to the better buoying and lubricating properties of the oil on the mineral particles.



Courtesy of Kent Machine Works.

FIG. 152.—Paint-grinding Mill.

Types of Bituminous Paints. *Masonry Paints.* These are used for painting brick, stone, or concrete surfaces, usually above ground, to prevent the inroads of dampness or moisture. Masonry paints often termed "damp-proofing paints," are divided into two classes, viz., clear and black.

Clear damp-proofing paints are used for painting the outside of exposed walls, and are generally made up from a base composed largely of paraffine wax in combination with resinous, oily or fatty constituents. Paraffine wax alone is only slightly soluble in most solvents, and has the disadvantage of crystallizing out at low temperatures. The addition of resins, vegetable or animal oils and fats will prevent this to a certain extent, and also maintain the necessary light color. These paints are intended to penetrate the pores of the masonry, and are therefore made thin in body, containing a large proportion of solvent (60 to 80 per cent by weight). The base is usually prepared of a low fusing-point to augment its solubility; and petroleum distillates, with or without the addition of wood distillates are generally used as solvents. Clear damp-proofing paints spread from 250 to 500 sq.ft. per gallon, depending upon the porosity of the underlying surface.

Black damp-proofing paints are made from asphaltic mixtures, water-gas-tar pitch, oil-gas-tar pitch and the various coal-tar pitches, used either alone or in combination with animal or vegetable fats or

oils. The base is prepared of a fairly low fusing-point (140 to 160° F. by the K. and S. method) and "cut" to a heavy body. Asphaltic bases are dissolved in 40 to 60 per cent of petroleum distillate, figured on the total weight; and bases derived from tars dissolved in 30 to 45 per cent of coal-tar distillate. This class of paints is used for coating the *inside* of exposed masonry walls, and may be plastered upon *directly*, thus dispensing with the furring and lathing. The best practice consists in applying two coats of the damp-proofing paint to the inside of the wall, allowing each to dry about twenty-four hours. The plaster may then be trowelled directly on the paint, with which it forms a good bond. Black damp-proofing paints containing saponifiable materials such as vegetable or animal oils and fats, or resins, bond better with the plaster than those made exclusively of asphaltic or coal-tar mixtures, in which latter case the bond tends to weaken when the paint ages. The paint should spread between 50 and 60 sq.ft. per gallon for the first coat, or 70 and 80 sq.ft. for the second, depending upon the character of the surface to which it is applied.

Paints for Recoating Prepared Roofings. These fall into two groups, namely those intended to repaint prepared roofings composed of asphaltic and coal-tar products respectively. For the former, asphaltic paints are used, and for the latter, paints prepared from pitches, and generally coal-tar pitch. For the cheapest paints, straight-distilled coal tar or crude asphalt-bearing petroleum are used. These form coatings of a nondescript character, due to their variable composition, and they also evaporate and harden slowly.

Higher grade paints of this class are prepared from substantially the same compositions used for the coatings of prepared roofings (p. 392), but of a slightly softer consistency and lower fusing-point (140 to 160, K. and S. method). These are dissolved in approximately an equal weight of solvent. When used as lap-cement, a smaller proportion of solvent is incorporated, and the paint is accordingly made heavier in body. Asphaltic paints should not be used on roofs containing coal-tar products, or vice versa.

In all cases, it is important that the base should be *plastic*, and have the same physical characteristics as the bituminous roofing to which it is applied. Paints containing a preponderance of "vegetable drying oils" such as linseed, china-wood, etc., fail to answer satisfactorily on bituminized roofings, for the following reasons:

- (1) Vegetable drying oils oxidize to an *elastic* substance known as "linoxyn," entirely devoid of plasticity, with the result that such coatings soon crack, check ("alligator"), and in certain cases peel off the roofing, when exposed to the weather.
- (2) Because the dark-colored bituminous constituents have the property of dif-

fusing or drawing through a coating of dried or oxidized vegetable oil, upon being subjected to the sun's heat, thereby causing the paint to assume a badly discolored or mottled appearance.

Bituminous materials interfere with the oxidation of vegetable drying oils, and if an excess of the former is present in the base, the entire composition will assume a "plastic" consistency, and the drying of the oil will be retarded. On the other hand, if the vegetable drying oil is in excess, it will oxidize in spite of the bituminous matters. The following table shows the relation between the consistometer hardness at 77° F. (Test 9c), and the percentage of commercial boiled linseed oil in admixture with gilsonite.

Gilsonite, Per Cent.	Boiled Linseed Oil, Per Cent.	Consistency at 77° F. (Test 9c).	Remarks.
100	0	100.0	} Unsuitable for coating prepared roofings.
95	5	98.0	
90	10	85.5	
85	15	70.0	} } Probable range permissible.
80	20	50.0	
75	25	20.5	
50	50	3.1	} Unsuitable for coating prepared roofings.
25	75	0.0	
15	85	0.0	
0	100	0.0	

Many unsuccessful attempts have been made to adapt linseed-oil-pigment-paints for coating prepared roofings, as for example, by first applying a priming coat of sodium silicate and rosin,¹ surfacing the roofing with fine sand,² etc.

To successfully paint prepared roofings in colors, a weather-proof *plastic* bituminous binder must be selected, having a light brown color in a thin layer (1-2 mils thick) when viewed by transmitted light on glass; otherwise yielding a brown streak on porcelain (Test 6). Gilsonite and certain forms of fatty-acid pitch (Group 1); mixtures of these with certain resins (Group 2); mixtures of these with a small proportion of vegetable oils or fats (Group 3); or mixtures containing both resins and vegetable drying oils (Group 4), will answer satisfactorily for this purpose, since they may be mixed with pigments without obliterating their color, as would be the case if dark-colored bituminous mixtures yielding a black streak were used.³ The base is dissolved in the volatile solvent and finally the colored pigment or mixture of pigments ground in. The ratio of pigment will vary from half to the same weight as the base, depending upon the intensity of the pigment, the opacity of the base, and the color of the paint desired. The percentage of volatile solvent must be increased slightly when pigments are used, due to the fact that these contribute to the body of the paint. A typical mixture will contain 30 per cent base, 20 per cent pigment, and 50 per cent volatile solvent.

¹ Ger. Pat. 219,181, of 1907 to H. Engelhardt.

² U. S. Pats. 291,600 of Jan. 8, 1884 to Josiah Jowitt; 385,057 of June 26, 1888 to Alexander Jones; 791,312 of May 30, 1905 to C. S. Bird.

³ U. S. Pat. 824,898 of July 3, 1906 to Herbert Abraham.

Bituminous Paints for Metal or Wood. All sorts of bituminous paint mixtures have been recommended for painting metal and wooden surfaces.¹

Bituminous paints give better results out-of-doors on metal than on wooden surfaces, although most manufacturers recommend them indiscriminately for both types of construction. However, it should be noted that any resinous constituents in the wood will act deleteriously on the paint after a time, due to their solvent action on the bituminous constituents present. Bituminous varnishes and enamels may safely be recommended under these conditions, since the excess of drying oil on oxidation becomes immune to the resinous constituents. If manufactured according to correct principles, bituminous paints will give fair service on exposed metal work, including metal roofs, corrugated iron, farm implements, etc., and although inferior in weather-resistance to bituminous varnishes and enamels, they are at the same time considerably less expensive. Bituminous paints have been used successfully for resisting the corrosive action of acids, alkaline solutions, cyanide liquors, etc. They are, in fact, more resistant to these chemicals than any other types of paints at present known. When used to withstand acids they will afford better protection to wood than to metal, due to the fact that wooden surfaces are in themselves more resistant to the action of acids, and being porous will absorb a greater quantity of paint, thus insuring a greater "factor of safety."

Bituminous paints will not give satisfaction when exposed to vapors or the direct contact of solvents for bituminous materials, such as petroleum products, illuminating gas, the so-called "gas-drip" condensing out of gas mains, turpentine, exudations of resinous woods, or the like. They may be applied on top of dried coatings of linseed oil paint or varnish, but should not be recoated therewith, as bituminous materials will form an unstable foundation, and for the reasons previously cited will act injuriously on the superimposed coating of dried linseed oil (linoxyn).

Certain bituminous paints, prepared without the use of mineral fillers or pigments are used for electrical insulating purposes where a rapid "air-drying" paint

¹ U. S. Pats. 109,757 of Nov. 29, 1870 to T. C. Rice, composed of coal tar, Venetian red and solvent; 188,646 of Mar. 20, 1877 to A. K. Lee, composed of asphalt alone and solvent; 207,096 of Aug. 20, 1878 to M. B. Bailey and 243,990 of July 5, 1881 to J. S. Smith composed of fatty-acid pitch and solvent; 235,365 of Dec. 14, 1880 to A. K. Lee, composed of asphalt, linseed oil, pigments and solvent; 237,017 of Jan. 25, 1881 to J. F. Hoffman, composed of asphalt, rosin and creosote oil; 240,899 of May 3, 1881 to J. L. Fauss, composed of coal-tar pitch, red iron oxide, ground slate and solvent; 243,990 of July 5, 1881 to J. C. Smith composed of fatty-acid pitch and solvent; 338,868 of Mar. 30, 1886, 348,993, 348,994 and 348,995 of Sept. 14, 1886, all to T. J. Pearce and M. W. Beardsley, composed of residual asphalt dissolved in carbon disulphide; 369,301 of Aug. 30, 1887 to G. W. Swan, composed of residual asphalt and pigments dissolved in benzene; 391,927 of Oct. 30, 1888 to J. A. Titzel composed of gilsonite, a small proportion of rubber, linseed oil, colored pigment and solvent; 394,396 of Dec. 11, 1888 to F. M. Reed, composed of asphalt, rosin, lime, stearine, red iron oxide and solvent; 701,743 of June 3, 1902 to T. L. Lee, composed of coal-tar pitch, dead oil, benzol and yellow ochre; 768,101 of Aug. 23, 1904 to F. M. Whitall, composed of wurtzilite asphalt and solvent; 835,113 of Nov. 6, 1906 to S. G. Penney, composed of blown petroleum asphalt, carbon tetrachloride and petroleum naphtha; 853,354 of May 14, 1907 to August Gross and A. C. Horn, composed of asphalt, Portland cement and pine oil; 967,337 of Aug. 16, 1910 to D. T. Day, containing nitrated asphaltites dissolved in a solvent; 984,477 of Feb. 14, 1911 to M. D. Griffin, et al., containing gilsonite, wurtzilite-asphalt, boiled linseed oil and solvent; Eng. Pats. No. 1932 of June 13, 1868, to Charles Humfrey, containing fatty-acid pitch, coal-tar pitch or residual asphalt dissolved in a volatile solvent; No. 12,632, Nov. 1, 1887, to J. H. Lyman, describing the use of residual asphalt dissolved in benzene.

is required. They are usually marketed under the erroneous term "air drying varnish," but are in reality air-drying paints. The author has examined specimens capable of withstanding 1000 volts per mil in thickness.

For manufacturing inexpensive machinery and farm implements, bituminous paints may be used for dipping purposes, upon thinning with additional solvent.

BITUMINOUS CEMENTS

These are of plastic, trowelling consistency and adapted for repairing metal or composition roofing, damp-proofing the inside of masonry walls above ground, and to a limited extent for waterproofing the outside of foundation walls below ground. The cement may be composed of two or more of the following constituents, viz.:

(1) A base containing one or more bituminous materials with or without the addition of vegetable oils, resins, etc. The ingredients should preferably be blended together in such proportions that the mixture will show a fusing-point (K. and S. method, Test 15*a*) between 135 and 175° F., a consistometer hardness (Test 9*b*) of 5 to 25 at 77° F., a susceptibility factor (Test 9*d*) below 25, and substantially complete solubility in the solvent used.

(2) Mineral fillers are sometimes added, comprising any of the products, such as clay,¹ etc., used for filling the coatings of prepared roofings (p. 393). Occasionally colored mineral pigments are used to impart to the cement, a color other than the inherently dark color of the bituminous materials. Even when employed in moderately large proportions, and of a strong intensity, they will result in comparatively dark hues.

(3) Fibrous matter is often added to bind the base together, and form a tougher mass when set. The fibres may either be of mineral, vegetable or animal origin, including asbestos,² slag wool, cotton flock, shoddy, rag fibres, etc. These are added in percentages not to exceed 15 per cent of the total. The waste product obtained in the manufacture of bituminized roofing or shingles may also be used for this purpose.³

(4) A volatile solvent in which the base will dissolve, consisting of petroleum products (e.g., gasolene, naphtha, or kerosene), distillates from rosin or wood (e.g., turpentine, wood turpentine, pine oil, wood creosote oil, etc.), tar distillates (e.g., benzol, coal-tar naphtha, solvent naphtha, creosote oil, etc.), used singly or in various combinations. The percentage of solvent will range from 10 to 25 per cent in weight, depend-

¹ U. S. Pat. 145,705 of Dec. 16, 1873 to Horace Wheeler.

² U. S. Pats. 76,773 of Apr. 14, 1868; 76,773 Re. 5948A and 5949B of June 30, 1874, all to H. W. Johns.

³ U. S. Pat. 1,253,454 of Jan. 15, 1918 to Herbert Abraham.

ing upon the nature of the base and the desired consistency of the cement.

The cement is manufactured by combining the base with the volatile solvent in one of two ways:

(1) By melting together the constituents in a so-called "varnish kettle" (p. 468) over direct fire heat, cooling until the mass commences to thicken and then gradually stirring in the solvent, small quantities at a time.

(2) By "cutting" the ingredients of the base with the solvent, in a closed steam-heated tank provided with a mechanical stirrer. The components of the base are weighed out separately, then the solvent added, the cover or cap of the tank screwed in place and steam turned on. The stirring is continued until the solution is complete, whereupon the charge is allowed to cool, the cover removed and the contents withdrawn. When mineral fillers, pigments or fibrous matters are to be used, they are incorporated cold, either by hand or with a power mixer.

The cement is ordinarily applied with a trowel in a layer from $\frac{1}{16}$ to $\frac{1}{8}$ in. thick, covering 25 to $12\frac{1}{2}$ sq.ft. respectively per gallon on a fairly smooth surface. The volatile solvent should evaporate within twenty-four hours, leaving the base and any mineral filler or fibrous constituents in the form of a weather-proof coating capable of withstanding the highest sun temperatures without softening or running, and sufficiently tough to withstand walking, attrition of the elements, or any expansive or contractive strains to which it may be subjected.

BITUMINOUS VARNISHES

These correspond to Groups 3 and 4 in the preceding classification (p. 463), but carry a larger percentage of vegetable drying oil, with the fillers and pigments absent. In other words, they consist of a bituminous base, a volatile solvent, animal or vegetable "drying oils" with or without the presence of resins. The proportion of oils should be sufficient so the base will possess a liquid to semi-liquid consistency and harden at room temperature by *oxidation* of the oils. *Hard* bituminous substances *only* are suitable for manufacturing varnishes, including the hard native asphalts, asphaltites, hard residual asphalts, wurtzilite asphalt, hard rosin pitch, hard wood-tar pitch, hard fatty-acid pitch and hard bone-tar pitch. Those ordinarily employed include asphaltites, hard native asphalts, hard fatty-acid pitches, and less frequently wurtzilite asphalt. The oils generally employed include linseed and china-wood, or a mixture of the two.

Asphaltic varnishes are prepared in the same manner as oleo-resinous varnishes, namely, in a varnish kettle. When fossil resins (copals) are to be used, they are first melted up or "depolymerized" at a temperature of 500 to 550° F., and when rendered fusible, the oils are added in the customary manner, then the dryers, and finally the asphalt or asphaltite. When the mixture has been thoroughly melted, it is allowed to cool and thinned with one or more volatile solvents.

When the varnish consists solely of bituminous matter and drying oil, one of three procedures may be followed, viz.:

(1) The oil or mixture of oils in the raw state may be fluxed with the bituminous matter, thereupon "bodied" at 500 to 525° F. until the mass becomes stringy, cooled to 400 to 450° F., then the dryers incorporated, and finally thinned with a volatile solvent.

(2) The oil or mixture of oils may first be bodied alone, then fluxed with the bituminous matter, the heat raised to about 500° F., cooled to 400 to 450° F., the dryers incorporated, and finally thinned.

(3) The oil, or mixtures of oils may first be bodied as in the foregoing, cooled to 400 to 450° F., the dryers incorporated, fluxed with the bituminous matter, cooled and thinned.

Each varnish maker has his own views as to the relative efficiency of these procedures.

Varnishes made from linseed oil alone are more durable on exposure to the weather, but they dry slower than mixtures containing china-wood oil. When china-wood oil is used, it must be heated above 500° F., to prevent the varnish drying with a "flat" or "frosted" appearance, but it should never be heated alone above 500° F., otherwise it will gelatinize and become infusible. The presence of 30 per cent linseed oil, resins or bituminous matter, or a combination of these will retard gelatinization but not prevent it. China-wood oil mixtures containing 50 per cent of one or more of these substances may be heated without danger of gelatinization.

Bituminous varnishes ordinarily contain 15 to 20 gallons of oil per 100 lbs. of bituminous matter, or mixtures of bituminous matter and resin. The durability of the varnish on exposure is in proportion to the quantity of oil present, so-called "long-oil varnishes" being more durable than "short-oil varnishes." Rosin esters have recently been used in combination with asphalts in this class of varnishes with good results, and prove fairly durable on exposure and waterproof.

The following dryers are generally used:

(1) Lead dryers in amounts ranging from 2-4 per cent by weight of the oil. Since the asphaltic varnishes are dark in color, it is unnecessary to use "pale" dryers, and consequently litharge (PbO) or red lead (Pb₃O₄) will answer satisfactorily.

(2) Manganese dryers in percentages of 1-2 per cent, usually in the form of manganese dioxide (MnO₂).

(3) Cobalt dryers in percentages of 1-2 per cent of the oil, and added in the form of cobalt acetate (CoA₂).

The best results are obtained by using combinations of lead and manganese; manganese and cobalt; or lead, manganese and cobalt in approximately the ratios specified. The addition of prepared liquid dryers to the cold varnish will not answer in the case of asphaltic varnishes as with oleo-resinous varnishes.

The following represent typical specifications for this type of varnish:

Specifications (M-L-N-55) issued by the U. S. War Dept., July, 1908, provide that "Asphalt varnish must be made of pure high-grade asphalt of the very best quality, of pure linseed oil and pure turpentine dryers only, and must not contain less than 20 gal. of prepared linseed oil to 100 gal. of varnish. It must not flash below 103° F. (open tester). It must mix freely with raw linseed oil in all proportions; it must be clear and free from sediment, resins and naphtha. When flowed on glass and allowed to drain in a vertical position, the film must be perfectly smooth, of good body, and must equal in this last respect the standard sample. It must set to touch in from 1½-2½ hours, and must dry hard in less than 20 hours at 70° F. When dry and hard it must not rub up and powder under friction of the finger. The application of heat must quicken the time of drying and give a harder film."

Specifications (52V-1a) issued by the U. S. Navy Dept., July 20, 1913, provide that "Black asphalt varnish must be made exclusively from pure high-grade asphalt of the very best quality, pure linseed oil, petroleum spirits, and lead-manganese dryers. It shall contain petroleum spirits, not less than 50 per cent nor more than 55 per cent by volume. The asphalt and linseed oil must be present in such proportions as to yield a film, after thorough drying, which shows no tendency to rub up or powder under friction of the finger. The flash-point by the open tester must not be below 100° F. It must mix freely with raw linseed oil. When flowed on glass and allowed to drain it should dry hard within 20 hours at 70° F., the film to be smooth and to possess full hiding power."

Varnishes containing china-wood oil will harden more rapidly than the foregoing. Bituminous varnishes will withstand exposure to the weather even better than oleo-resinous varnishes, although their use is limited by their inherently dark color, which restricts them for coating metal work either out-of-doors or in-doors. They produce lustrous coatings on drying. Other things being equal the blacker the streak on porcelain of the bituminous base, the more intense will be the color, covering power and opacity of the resulting varnish. If too large a proportion of the resin or oil is used in its manufacture, the varnish will dry with a translucent film possessing a brownish black to deep brown color, having little value for coating structural objects. Such varnishes are sometimes used by artists to produce warm brown tones, and were so employed by the ancient masters, who possessed the secret of preventing them diffusing through and discoloring the light-colored paints in juxtaposition.

BITUMINOUS ENAMELS

These are prepared from bituminous varnishes by grinding in dry pigments sufficiently intense to overcome the inherently dark color of the varnish. The enamels at best can be manufactured in comparatively dark hues only, which limit their scope of usefulness. They have

the advantages of extreme durability and low cost, since bituminous materials are less expensive than the resins otherwise used for this purpose.

The bituminous varnishes to be used for manufacturing enamels are made as translucent as possible to favor the color of the pigment. Bituminous substances showing a *brown* streak are accordingly selected, and combined with substantial amounts of resinous and oily bodies. Gilsonite constitutes the most popular base, since it shows the optimum brown color, possesses the necessary hardness, and at the same time does not tend to gelatinize with lead, zinc and chromium pigments.

The pigments are incorporated in the vehicle by grinding through a paint mill, p. 469. The following pigments may be used:

Red iron oxide to produce deep reds and maroons.

Chrome green to produce deep shades of green and olive.

Yellow ochre to produce browns.

Chrome yellow to produce deep yellows and browns.

Lithopone, zinc white, white lead and sublimed lead to produce tans (without other additions).

Graphite used either alone or in combination with lampblack or carbon black for coating structural steel, and metal roofs.

BITUMINOUS JAPANS

In this treatise the term "japan" is used to designate a dark-colored menstruum applied to metals, wood, fabrics, etc., intended to be hardened by *baking*. Japans are sometimes used for impregnating felted or woven fabrics for electrical insulating purposes. In composition they fall into any of the four groups enumerated on p. 462, the fillers and pigments being omitted. The base of cheap japans is composed solely of bituminous materials blended in the proper proportions, whereas the better grades are made from mixtures of bituminous materials and vegetable drying oils, with or without the addition of resin. They are opaque black to translucent brown in color, and after baking, form coatings which are extremely hard, tough and resistant to abrasion.

Japans are often made from semi-solid native asphalts, and in some cases residual asphalts derived from aromatic-base petroleum having the property of hardening on "baking." Toughness may be imparted by fluxing with a small percentage of blown petroleum asphalt or fatty-acid pitch. Fatty-acid pitches which have been over-heated in their process of manufacture, are especially suitable for this purpose being often used alone. The characteristics of bituminous substances suitable for manufacturing japans are as follows:

(1) They must be homogeneous and free from any fine particles of grit.

(2) They should show a black streak, and be opaque when viewed in a thin layer.

(3) They must not separate, curdle or "gelatinize" on thinning with petroleum naphtha.

(4) They must bake in a reasonable length of time to a tough and permanently glossy coating, without shrivelling or "crazing."

A popular form of japan consists of gilsonite fluxed with a fatty-acid pitch of the type described, and thinned with petroleum naphtha to brushing consistency. If the fatty-acid pitch does not bake sufficiently rapid, a common scheme consists in combining a small percentage of dryer such as manganese dioxide or raw umber, at a temperature of 450° F. Tougher and more elastic japans are prepared by incorporating a proportion of bodied linseed oil, which also serves to improve the gloss.

Since semi-drying vegetable and animal oils will oxidize to tough coatings at elevated temperatures, and are usually less expensive, they may be substituted for the vegetable drying oils, especially if bodied and combined with dryers. Thus cottonseed oil, corn oil, soya bean oil, and fish oil have been used for this purpose, sometimes combined with a small percentage of china-wood oil to accelerate the drying. Another expedient consists in bodying the vegetable oils at 450-475° F. with a small proportion of Prussian blue ($\frac{1}{2}$ -1 ounce per gallon), which serves to convert the oil into a brownish black liquid, thus increasing the opacity of the japan, and at the same time imparting drying properties to the oil. This is the same procedure followed in manufacturing baking varnishes and japans for the patent-leather industry.

Japans are applied to articles by dipping, brushing or spraying, and heated in specially constructed ovens from 1-4 hours at 200-400° F. depending upon their composition. Modern practice favors the use of higher temperatures for shorter periods of time. Wooden and other porous articles must be baked longer than metal. Semi-glossy and flat black japans are prepared by grinding carbon- or lampblack in the foregoing menstrua, and when baked present a surface simulating the appearance of hard rubber. Sometimes a small percentage of oxidized zinc is incorporated to impart a grayish cast. Baked japans form a harder, tougher and more weatherproof coating than those resulting from bituminous varnishes allowed to air-dry at room temperature.¹

Japans containing 10-17 gal. of drying oil per 100 lbs. of solid constituents are employed for insulating armature and field coils of motors and dynamos, also transformer and magnet coils, in small plants where vacuum impregnating apparatus is not available (p. 449). The coils after having been wound with cotton or other fibrous material are heated in an oven until the moisture has been expelled, and while still hot are dipped into the cold japan. After removing and allowing the excess to drain, the coils are baked in an oven at 180-200° F., usually from 8-12 hours. It is advisable to dip and bake the coils twice to insure thorough impregnation. These japans are sold under the trade name of "black baking varnish," and if properly prepared will withstand an alternating current having a potential of 800-1000 volts per mil, after having been baked 300 hours. One of the essential characteristics of the "varnish" is that it shall neither soften nor become brittle when applied to armatures of dynamos or motors subjected to continual vibration, and often becoming heated as high as 190° F. in service. Should the varnish or japan

¹ "The Application of Gas to Japaning and Lacquering," by E. F. Davis, published by the National Commercial Gas Association, Brooklyn, N. Y., 1916.

become brittle, the vibration will soon cause it to crack and pulverize, and result in short-circuiting the machine. This is one of the severest tests to which any form of varnish is subjected. It requires considerable skill to prepare a japan that will retain its pliability on long service when subjected to alternate heating and cooling in contact with air, combined with the vibrating and centrifugal action exerted by the revolving armature. A simple test consists in baking the japan on a small strip of muslin at 195° F. for 300 hours, and then observing whether it can be bent double (flat on itself) without cracking at 77° F. It must also withstand continuous immersion in hot lubricating oil without softening or disintegrating.

Resins are sometimes added to the baking japons, but are not looked upon with favor because of their tendency to make the coating brittle.

PART V

METHODS OF TESTING

CHAPTER XXVIII

PHYSICAL CHARACTERISTICS

CHAPTERS XXVIII, XXIX, XXX and XXXI will be devoted to a description of the most important tests used for examining crude, refined and blended bituminous substances. Certain of the tests have been adopted as standards by technical societies, and particularly the American Society for Testing Materials, whose committees have been active in this field, accomplishing much to clarify what formerly constituted a veritable jumble of rule-of-thumb methods. Other tests appearing in the current literature will be included where they have been found adequate, but in certain cases these have been amplified or elaborated to conform with the practice followed in the author's laboratory. The author, however, assumes full responsibility for any methods described which have not been proposed or adopted as "standard."

The tests which follow are grouped under four headings, viz., physical characteristics, heat tests, solubility tests and chemical tests, a chapter being devoted to each. In general, a test may have one or more objects in view, viz.:

- (1) Serving as a means of identification.
- (2) Ascertaining the value of the substance for a given use.
- (3) Gauging the uniformity of its supply.
- (4) An aid to factory control in its manufacture, refining or blending, and
- (5) As a criterion of its quality.

The last named may serve as an indication of its purity, the care exercised in its preparation, or its intrinsic value. The tests pertaining to bituminous substances fulfil these requirements as shown in Table XXXIV.

TABLE XXXIV

Number.	Description.	For Purposes of Identification.	Adaptability for a Given Purpose.	Gauging the Uniformity of Supply.	Purposes of Factory Control.	As a Criterion of the Quality.*
<i>Physical Characteristics :</i>						
(Test 1)	Color in mass.....	YES
(Test 2)	Homogeneity.....	YES	Yes	Yes	Yes	YES
(Test 3)	Appearance surfaced aged one week....	Yes	YES	YES
(Test 4)	Fracture.....	YES
(Test 5)	Lustre.....	Yes	YES	YES
(Test 6)	Streak on Porcelain.....	YES	Yes
(Test 7)	Specific gravity.....	YES	Yes	Yes
(Test 8)	Viscosity.....	YES	Yes	Yes
(Test 9)	Hardness or consistency.....	YES	YES	YES	YES
(Test 9d)	Susceptibility factor.....	YES	YES	YES	YES
(Test 10)	Ductility.....	YES	Yes	Yes
(Test 11)	Tensile strength.....	YES
(Test 12)	Adhesiveness.....	YES
<i>Heat Tests:</i>						
(Test 13)	Odor on heating.....	YES
(Test 14)	Upon subjecting to heat.....	YES
(Test 15)	Fusing-point.....	YES	YES	YES	YES
(Test 16)	Volatile matter.....	Yes	YES	Yes	Yes
(Test 17)	Flash-point.....	YES	Yes	Yes
(Test 18)	Burning-point.....	YES
(Test 19)	Fixed carbon.....	YES
(Test 20)	Distillation test (for tars).....	Yes	YES	Yes	Yes	YES
<i>Solubility Tests:</i>						
(Test 21)	Solubility in carbon disulphide.....	YES	YES	YES	YES
(Test 22)	Carbenes.....	Yes	Yes	Yes	YES
(Test 23)	Solubility in 88° petroleum naphtha..	YES	Yes	Yes	Yes
(Test 24)	Solubility in other solvents.....	Yes	YES
<i>Chemical Tests:</i>						
(Test 25)	Water.....	Yes	YES
(Test 26)	Carbon.....	YES
(Test 27)	Hydrogen.....	YES
(Test 28)	Sulphur.....	YES
(Test 29)	Nitrogen.....	YES
(Test 30)	Oxygen.....	YES
(Test 31)	Free carbon in tars.....	YES	Yes	Yes
(Test 32)	Naphthalene in tars.....	YES
(Test 33)	Solid paraffines.....	YES
(Test 34)	Saturated hydrocarbons.....	YES
(Test 35)	Sulphonation residue.....	YES
(Test 36)	Mineral matter.....	YES	YES	YES	Yes	YES
(Test 37)	Saponifiable constituents.....	YES	Yes	YES
(Test 38)	Asphaltic constituents.....	YES
(Test 39)	Unsaponifiable matter.....	YES	Yes	YES
(Test 40)	Glycerol.....	YES
(Test 41)	Diazo reaction.....	YES
(Test 42)	Anthraquinone reaction.....	YES
(Test 43)	Liebermann-Storch reaction.....	YES

* (a) Purity; (b) Care exercised in its preparation; (c) Intrinsic value.

TABLE XXXV.—SYNOPTICAL TABLE OF THE MOST IMPORTANT

	Fracture (Test 4).	Streak (Test 6).	Sp.gr. at 77° F. (Non-mineral Matter) (Test 7).	Consistency at 77° F. (Test 9c).	Susceptibility Factor (Test 9d).	Fusibility of (K and S. Method) (Test 15a)
Non-asphaltic petroleum.....			0.75-0.90	Liquid		<0
Mixed-base petroleum.....			0.80-0.95	Liquid		<0
Asphaltic petroleum.....			0.85-1.00	Liquid		<0
Ozokerite.....	Conc. to H	Wh. to Yel.	0.85-1.00	20-40	> 80	140-200
Montan wax.....	Conch.	Yel.	0.90-1.00	> 100	> 100	170-200
Paraffine wax.....	Conc. to H	Wh.	0.85-0.95	15-80	> 100	100-150
Native asphalts (contg. less than 10% mineral matter).....	Variable	Bn. to Bk.	0.95-1.12	0-> 100	15-> 100	60-325
Native asphalts (contg. greater than 10% mineral matter).....	Variable	Bn. to Bk.	0.95-1.15	5-> 100	30-> 100	60-350
Residual oils.....			0.85-1.05	0-7		0-80
Blown petroleum asphalts.....	Variable	Bn. to Bk.	0.90-1.07	2-30	8-40	80-300
Residual asphalts.....	Conch.	Bk.	1.00-1.17	5-100	40-60	80-225
Sludge asphalts.....	Conch.	Bk.	1.05-1.20	5-100	40-60	80-225
Wurtzilite asphalt.....	Conch.	Bn. to Bk.	1.04-1.07	20-50	30-40	150-300
Gilsonite.....	Conch.	Bn.	1.05-1.10	90-120	> 100	250-350
Glance pitch.....	Conc. to H	Bk.	1.10-1.15	90-120	> 100	250-350
Grahamite.....	Conc. to H	Bk.	1.15-1.20	> 150	> 100	350-600
Elaeterite.....		Bn.	0.90-1.05	Rubbery		Inf.
Wurtzilite.....	Conc. to H	Bn.	1.05-1.07	> 150		Inf.
Albertite.....	Conc. to H	Bn. to Bk.	1.07-1.10	> 150		Inf.
Imponite.....	Hackly	Bk.	1.10-1.25	> 150		Inf.
Asphaltic pyrobituminous shales.....	Conch.	Var.	1.50-1.75	> 150		Inf.
Peat (dry).....	Variable	Bn.	0.15-1.05	> 150		Inf.
Lignite (dry).....	Variable	Bn.	1.00-1.25	> 150		Inf.
Bituminous coal.....	Hackly	Bn. to Bk.	1.20-1.40	> 150		Inf.
Anthracite coal.....	Conc. to H	Bk.	1.30-1.60	> 150		Inf.
Non-asphaltic pyrobituminous shales	Conch.	Var.	1.30-1.75	> 150		Inf.
Wax tailings.....		Yel.	1.00-1.10	5-20	20-40	60-100
Oil-gas tar.....			0.95-1.10	0		<0-20
Oil-gas-tar pitch.....	Conch.	Bk.	1.15-1.30	10-100	> 100	80-275
Water-gas tar.....			1.05-1.15	0		<0-10
Water-gas-tar pitch.....	Conch.	Bk.	1.10-1.20	10-100	> 100	80-275
Pine tar.....			1.05-1.10	0		0-50
Pine-tar pitch.....	Conch.	Bn.	1.10-1.15	10-100	> 100	100-200
Hardwood tar.....			1.10-1.20	0		0-20
Hardwood-tar pitch.....	Conch.	Bn. to Bk.	1.20-1.30	10-100	> 100	100-200
Rosin pitch.....	Conch.	Yel. to Bn.	1.08-1.15	50-100	> 100	120-200
Peat tar.....			0.90-1.05	0		40-60
Peat-tar pitch.....	Conch.	Bn. to Bk.	1.05-1.15	10-100	> 100	100-250
Lignite tar.....			0.85-1.05	0		60-90
Lignite-tar pitch.....	Conch.	Bk.	1.05-1.20	10-100	> 100	100-250
Shale tar.....			0.85-0.95	0		60-90
Gas-works coal tar.....			1.15-1.30	0		<0-25
Gas-works coal-tar pitch.....	Conch.	Bk.	1.15-1.40	10-100	> 100	80-300
Coke-oven coal tar.....			1.10-1.30	0		<0-25
Coke-oven coal-tar pitch.....	Conch.	Bk.	1.20-1.35	10-100	> 100	80-300
Blast-furnace coal tar.....			1.15-1.30	0		<0-25
Blast-furnace coal-tar pitch.....	Conch.	Bk.	1.20-1.30	10-100	> 100	80-300
Producer-gas coal tar.....			1.15-1.30	0		<0-25
Producer-gas coal-tar pitch.....	Conch.	Bk.	1.20-1.35	10-100	> 100	80-300
Bone tar.....			0.95-1.05	0		<0-10
Bone-tar pitch.....	Conch.	Bk.	1.10-1.20	10-100	75-100	80-225
Fatty-acid pitch.....	Variable	Yel. to Bk.	0.90-1.10	0-40	8-40	35-225

DISTINGUISHING CHARACTERISTICS OF BITUMINOUS SUBSTANCES

Fixed Carbon (Test 19).	Solubility in Carbon Disulphide (Test 21a).	Non-mineral Matter Insoluble (Test 21b).	Mineral Matter (Test 21c).	Carbenes (Test 22).	Soluble in 88° Naphtha (Test 23).	Oxygen in Non- mineral Matter (Test 30).	Paraffine (Test 33).	Sulphonation Residue (Test 35).	Saponifiable Matter (Test 37).	Diazo Reaction (Test 41).	Antraquinone Reaction (Test 42).
%	%	%	%	%	%	%	%	%	%	No	No
1/2-2	98-100	0-1/2	0-2	0-1/2	98-100	0-2	10-25	90-100	0-2	No	No
2-5	98-100	0-1	0-2	0-1	95-100	0-3	1/2-10	85-95	0-2	No	No
5-10	98-100	0-1	0-2	0-1	90-100	0-5	0-Tr.	80-95	0-5	No	No
1/2-10	95-100	0-1	0-5	0-3	75-95	0-2	50-90	90-100	0-2	No	No
2-10	98-100	0-2	0-2	0-2	80-100	3-6	0-10	0-10	50-80	No	No
0-2	99-100	0-1/2	0-1/2	0	99-100	0-Tr.	95-100	95-100	0	No	No
1-25	60-98	0-40	0-10	0-5	25-95	0-2	0-5	90-100	0-2	No	No
5-25	Tr.-90	0-25	10-95	0-5	Tr.-85	0-2	0-5	90-100	0-2	No	No
2-10	98-100	0-1/2	0-1/2	0-1	80-99	0-3	0-15	90-100	Tr.-5	No	No
5-20	95-100	0-5	0-1/2	0-10	50-90	2-5	0-10	90-100	Tr.-2	No	No
5-40	85-100	0-15	0-1	0-30	25-85	0-2 1/2	0-5	90-100	0-2	No	No
5-30	95-100	0-5	0-1	0-15	60-95	3-7	0-1/2	80-95	0-2	No	No
5-25	98-100	0-1/2	Tr.-2	0-2	50-80	0-2	0-Tr.	90-95	0-2	No	No
10-20	98-100	0-1	Tr.-1	0-1/2	40-60	0-2	0-Tr.	85-95	Tr.	No	No
20-30	95-100	0-1	Tr.-5	0-1	20-50	0-2	0-Tr.	85-95	Tr.	No	No
30-55	45-100	0-5	Tr.-50	0-80	Tr.-50	0-2	0-Tr.	80-95	Tr.	No	No
2-5	10-20	70-90	Tr.-10	Tr.-2	5-10	1-5	0-Tr	80-90	Tr.-15	No	No
5-25	5-10	80-95	Tr.-10	Tr.-2	Tr.-2	0-2	0-Tr.	90-98	Tr.	No	No
25-50	2-10	85-98	Tr.-10	Tr.-2	Tr.-2	0-3	0-Tr.	90-98	Tr.	No	No
50-85	1-6	90-99	Tr.-10	Tr.-2	Tr.-2	0-3	0-Tr.	90-98	Tr.	No	No
2-25*	Tr.-3	15-70	30-85	0-Tr.	0-Tr.	0-3	Tr.-3	90-98	Tr.	No	No
15-35	2-6	15-98	2-80	0-2	0-5	26-44	Tr.-15	No	No
25-50	2-15	65-98	2-25	0-1	5-10	15-28	Tr.-5	No	No
35-75	1/2-2	75-98	2-25	0-1/2	0-1	3-18	Tr.-1	No	No
60-90	0-1/2	75-98	2-25	0	0	1-5	0	No	No
20-45*	0-1	15-70	30-85	0	0-1/2	3-15	Tr.-2	No	No
2-8	98-100	0-2	0-Tr.	0-Tr.	95-100	0-2	Tr.-5	90-100	Tr.	No	Yes
10-25	98-100	0-2	0-1	0-2	50-85	1-2	0-5	20-40	Tr.	Yes	Yes
20-30	85-98	2-15	0-1	2-20	65-85	0-2	0-5	20-40	0-1	Yes	Yes
10-20	98-100	0-2	0-1	0-2	20-75	1-2	0-5	0-15	Tr.-2	Yes	Yes
25-40	85-98	2-15	0-1	2-15	50-80	0-2	0-5	0-15	0-1	Yes	Yes
5-15	98-100	0-2	0-1	0-2	65-95	5-10	0	Tr.-5	10-50	Yes	No
10-25	40-95	2-60	0-1	0-5	25-80	2-8	0	Tr.-3	10-40	Yes	No
5-20	95-100	0-5	0-1	0-2	50-90	2-10	0	Tr.-5	5-25	Yes	No
15-35	30-95	5-70	0-1	2-10	15-50	1-5	0	Tr.-5	5-25	Yes	No
10-20	98-100	0-2	0-1	0-5	90-100	5-10	0	Tr.-5	25-95	Yes	No
5-15	98-100	0-2	0-1	0-2	95-100	5-15	5-15	5-15	5-15	Yes	No
10-30	95-99	0-5	0-1	0-5	65-95	2-8	2-5	5-10	0-5	Yes	No
5-20	98-100	0-1	0-1	0-2	95-100	5-10	10-25	10-20	5-20	Yes	No
10-40	95-99	0-2	0-1	0-5	75-95	2-5	1-5	5-15	0-5	Yes	No
5-10	98-100	0-2	0-1	0-2	95-100	1-5	5-15	15-35	0-2	Yes	No
15-40	60-95	5-40	0-1	0-2	20-40	1-3	0	0-5	2-5	Yes	Yes
30-45	55-90	10-45	0-1	2-10	10-30	Tr.-2	0	0-5	Tr.-1	Yes	Yes
15-40	80-97	3-20	0-1	0-2	20-40	1-3	0	0-5	2-5	Yes	Yes
20-45	60-85	15-40	0-1	2-10	10-30	Tr.-2	0	0-5	Tr.-1	Yes	Yes
5-25	65-80	10-25	10-15	0-2	15-35	1-3	0	5-20	2-5	Yes	Yes
10-30	50-75	15-35	10-20	2-10	5-25	Tr.-2	0	5-20	Tr.-1	Yes	Yes
10-35	75-90	10-25	0-2	0-2	20-40	1-3	0	0-5	2-5	Yes	Yes
25-45	60-85	15-40	0-2	2-10	10-30	Tr.-2	0	0-5	Tr.-1	Yes	Yes
5-15	95-100	0-5	0-Tr.	0-2	95-100	2-8	0	0-5	5-40	Yes	No
15-25	85-95	1-15	0-Tr.	0-10	75-95	0-2	0	0-5	2-25	Yes	No
5-35	95-100	0-5	0-5	0-5	80-100	2-10	Tr.	0-5	5-98	No	No

* Calculated on mineral-free basis.

Table XXXV contains a list of the principal bituminous substances, together with such physical and chemical tests as will enable them to be distinguished one from another. Under each heading the minimum and maximum figures are included, based on the author's experience. His intention has been to make the range sufficiently liberal to cover all the commercial varieties, and at the same time prevent the range being too broad, since this would result in unnecessary overlapping.

Test 1. Color in Mass. This test is used largely for purposes of identification, and consists in examining a freshly prepared surface of the bituminous material in daylight. The colors range from white, through the various shades of yellow, brown and black. Some possess a greenish or reddish cast, and again others may appear fluorescent. Purified mineral waxes appear pure white, wax tailings a bright yellow, asphalts and pitches are generally brownish black, grayish black or black.

Test 2. Homogeneity. This test is used for purposes of identification, for determining the adaptability of the bituminous substance to a given purpose, for gauging the uniformity of supply, for purposes of factory control, as a rough criterion of the purity, and when the bituminous mixture is free from mineral and carbonaceous matter, for ascertaining whether a complete amalgamation of the constituents occur, especially after fluxing (p. 343).

Test 2a. Homogeneity to the Eye at 77° F. With soft materials this may be ascertained by disturbing a freshly prepared surface of the material (cooled to room temperature) with a rod or spatula, and observing whether any dulling occurs. An alternate method consists in drawing a small pellet into a thread between the fingers, and noting whether it dullens while being drawn out. With hard and brittle substances a freshly fractured surface may be examined. Any evidence of dullness is an indication of: (1) the presence of mineral matter, (2) the presence of free carbon (non-mineral matter insoluble in carbon disulphide), (3) an imperfect blending of the bituminous constituents.

Test 2b. Homogeneity under Microscope. This is ascertained by spreading a minute quantity of the bituminous material on a microscope slide in a thin layer and examining it by transmitted light under a magnification of 100 to 250 diameters. With hard bituminous materials, the slide should be warmed and the specimen spread uniformly and thinly, while melted. This test manifests the same characteristics as the preceding, and in addition, permits the detection of the solid paraffines, which separate from the bituminous matrix in crystal-like masses, Paraffine may be identified positively under a microscope equipped with a polariscopic attachment.

Test 2c. Homogeneity When Melted. This constitutes a rough test for detecting the presence of substantial amounts of extraneous matter, such as mineral constituents or free carbon. The bituminous material is simply melted and stirred with a rod. If these constituents are present in large quantities, they will impart a gritty feel to the mass, and will often settle out on standing.

Test 3. Appearance Surface Aged Indoors one Week. A small quantity of the bituminous material is carefully melted at the lowest possible temperature and poured into a tin ointment box or deep seamless can as used for determining the volatile matter (Test 16). The surface should be free from froth or bubbles and allowed to cool in a place free from draughts. When cool, the surface is examined, and then covered to protect it from dust. At the end of a week the cover is removed and the surface re-examined. If bright and lustrous, it will indicate a perfect amalgamation of the constituents, also the absence of oily, greasy and undissolved constituents. A lustreless surface is an indication of the presence of extraneous mineral or carbonaceous matter, or evidence that the constituents do not blend or amalgamate properly. If the surface appears greasy or wax-like, vaseline- or paraffine-like bodies are present, since these have the property of separating or "sweating" from the bituminous matrix on standing. This would prove objectionable where the bituminous material is to be used for surfacing prepared roofings dusted with talc, or for manufacturing bituminous paints, varnishes or japans. This test is accordingly used for purposes of identification, determining the adaptability of the substance for a given purpose and as a criterion of its quality.

Test 4. Fracture. This is ascertained upon cleaving the specimen by subjecting it to a sharp blow, and examining the cleavage surface. Only hard and "brittle" bituminous substances will yield to this test, including the hard asphalts and asphaltites. The fracture may either appear conchoidal (rounded and curved like a shell), or hackly (jagged, irregularly and rough).

Test 5. Lustre. This indicates the manner in which light is reflected from a freshly fractured surface, and may be bright or vitreous—indicating that it has the brilliancy or shine of glass; greasy—indicating that it presents an oily or greasy surface; waxy—indicating that it has the characteristic appearance of wax; or dull—indicating that the surface is without lustre. These manifestations are used for purposes of identification, and for determining the adaptability of the bituminous material for manufacturing paints, varnishes and japans.

Test 6. Streak on Porcelain. This represents the color of the powder which is left behind on drawing a piece of the solid bituminous material across the surface of unglazed porcelain. Hard bituminous materials only will yield to this test. The streak may be classified as white (where no streak is visible), yellowish, yellowish brown, brown, brownish black and black. This test is of value for purposes of identi-

fication, and as an indication of the suitability of the substance for use with colored pigments.

Test 7. Specific Gravity. This test is of value (1) in identifying bituminous materials; (2) for controlling the uniformity of supply, (3) for purposes of factory control, (4) for figuring the weight of a given volume as delivered in tank cars, when stored in tanks or else upon filling into containers, (5) for calculating the volume of the bituminous binder in pavements (p. 364). The specific gravity is of special value when considered in connection with the fusing-point (p. 293) or hardness.

Test 7a. Hydrometer Method for Fluid Materials. Where speed is essential and great accuracy not required, the specific gravity of fluid bituminous materials may be determined with a hydrometer having its scale sub-divided to unity in the third place of decimals. Usually a series of hydrometers are used, ranging respectively from 0.800 to 0.900, 0.900 to 1.000, 1.000 to 1.080, 1.070 to 1.150, 1.150 to 1.230, and in such dimensions as to enable them to be used in a 100 c.c. cylinder 300 mm. long (with a permissible variation of 30 mm.) and 32 mm. in diameter (with a permissible variation of 3 mm.). The hydrometer should be of the form shown in Fig. 153, and have the following dimensions: length of stem 125 mm. (± 12.5 mm.), length of bulb 105 mm. (± 10.5 mm.), length of scale 80 mm. (± 8.0 mm.), diameter of stem 6 mm. (± 0.5 mm.), diameter of bulb 22 mm. (± 2.0 mm.).¹

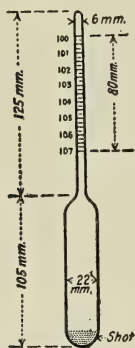

From A. S. T. M. Standards.

FIG. 153.—Hydrometer.

Most hydrometers are adapted to read at 60° F./60° F., or in other words, the instrument is calibrated for water at 60° F. taken as unity. The standard temperature for testing bituminous materials is 77° F., and they should accordingly be brought to this temperature when tested with the hydrometer. For correcting the reading to water at 77° F., it should be multiplied by 1.002, as follows:

$$\text{Sp.gr. at } 77^\circ \text{ F./}77^\circ \text{ F.} = \text{Sp.gr. at } 77^\circ \text{ F./}60^\circ \text{ F.} \times 1.002.$$

In running the test, the bituminous material is brought to a temperature of 77° F., immediately poured into the hydrometer jar, and then the hydrometer slowly allowed to sink into it until it comes to a definite resting-point, whereupon it is raised slightly, and allowed to sink a second time. The reading is then noted. The hydrometer must not be pushed below the point at which it comes to rest until after the second reading has been taken, then it should be pushed a slight distance below the end point to observe whether or not it will rise. If it fails to do so, it is evident that the bituminous material is too viscous to be tested by the hydrometer method, and some other method should be employed. Care should be taken that the hydrometer does not touch the sides or bottom of the cylinder when

¹ "Standard Methods for Sampling and Analysis of Creosote Oil" (Serial Designation: D 38-17) of the Am. Soc. Testing Materials, *A. S. T. M. Standards Adopted in 1917*, 34.

the reading is taken, also that the surface of the liquid is free from froth or bubbles.¹

For converting specific gravity into degrees Baumé and vice versa, the following formulae may be used:²

For liquids lighter than water:

$$^{\circ}\text{Baumé} = \frac{140}{\text{Sp.gr. } 60^{\circ}/60^{\circ} \text{ F.}} - 130$$

$$\text{Sp.gr. } 60^{\circ}/60^{\circ} \text{ F.} = \frac{140}{130 + ^{\circ}\text{Baumé}}$$

For liquids heavier than water:

$$^{\circ}\text{Baumé} = 145 - \frac{145}{\text{Sp.gr. } 60^{\circ}/60^{\circ} \text{ F.}}$$

$$\text{Sp.gr. } 60^{\circ}/60^{\circ} \text{ F.} = \frac{145}{145 - ^{\circ}\text{Baumé}}$$

Test 7b. Westphal Balance Method. This is also adapted to testing fluid bituminous materials. The instrument as supplied by the manufacturer (Fig. 154) is provided with a cylinder of about 50 c.c. capacity, calibrated for use at 60°/60° F. If the test is to be made at 77° F., it is subject to the same correction as in the hydrometer method.

The Westphal balance may be adapted for as little as 8 c.c. of the bituminous material, by using a special plummet small enough to fit into a 10 c.c. cylinder. The plummet may be made from a piece of glass tubing 7 mm. outside diameter, which is sealed at one end with a short platinum wire fused into the glass. Nine to ten grams of mercury are placed in the tube forming a column 35–40 mm. high. The tube is then cut off within 20 mm. of the top of the mercury column, and the open end sealed with a blow-pipe. This plummet should measure 55–60 mm. over all, and weigh from 10 to 12 g. If a represents the weight of the plummet in air, b its weight in water at a definite temperature, and c its weight in the bituminous material at the same temperature, then the specific gravity of the bituminous material at this tem-

$$\text{perature} = \frac{c - a}{b - a}.$$
³

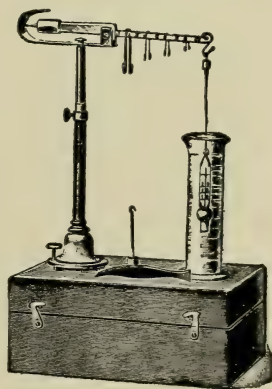

Courtesy of Eimer & Amend.
FIG. 154.—Westphal Balance.

¹ Bulletin No. 314, U. S. Dept. of Agr., Wash., D. C., Dec. 10, 1915; "Laboratory Manual of Bituminous Materials," by Prévost Hubbard, p. 30, N. Y., 1916; "Specific Gravity—its Determination for Tars, Oils and Pitches," by J. M. Weiss, *J. Ind. Eng. Chem.*, **7**, 21, 1915.

² Circular No. 19, Bureau of Standards, "Standard Density and Volumetric Tables," Wash., D. C., 1916; Circular No. 59 Bureau of Standards, "U. S. Standard Baumé Hydrometer Scales," Wash., D. C., 1916.

³ "Standard Methods for Sampling and Analysis of Creosote Oil" (Serial Designation: D 38-17) of the Am. Soc. Testing Materials, *A. S. T. M. Standards Adopted in 1917*, 40.

Test 7c. Pycnometer or Specific-Gravity Bottle Method. Several forms of glass bottles are used for this purpose, with a ground-glass stopper having a small vertical hole bored through to enable it to be completely filled with the bituminous material. These are made in various sizes.

An improvised form which may be used to good advantage when a small quantity of liquid bituminous material is available, consists of a 1 c.c. pipette, and a glass tube sealed at one end, the inside diameter of which is slightly larger than the outside diameter of the lower stem of the pipette. On using this instrument, the liquid is first brought to a definite temperature, then sucked to the upper mark of the pipette by means of a piece of rubber tubing temporarily attached to its upper stem. The outside is carefully wiped dry and the lower stem inserted in the glass tube which serves to retain any liquid which may drain from the pipette. A small piece of wire twisted about the pipette near the top is formed into a ring to hang it from the hook above the balance pan. The pipette is thus supported in a vertical position and weighed.¹

If *a* represents the weight of the pipette with glass tube empty, *b* its weight filled with water at a definite temperature, and *c* its weight filled with the bituminous material at the same temperature, then the specific gravity may be calculated from the following formula:

$$\frac{c-a}{b-a}$$

It is customary to determine the specific gravity of bituminous materials at 77°/77° F., although in special instances it is expressed at 60°/60° F., and in the case of creosote oil at 100°/60° F. For converting the specific gravity of a substance found at a higher temperature to the standard temperature (lower), the following formula should be used:

$$\text{Sp.gr. Substance at } t_1/t_1 = \text{Sp.gr. Substance at } t_2/t_1 + k(t_2 - t_1).$$

in which *t*₂ = the temperature at which the specific gravity of the substance was determined,

*t*₁ = the temperature (lower) at which the specific gravity of the substance is to be calculated, and

k = the coefficient of expansion, which is constant for any particular substance.

If perchance the specific gravity of the substance has been compared with that of water at a higher temperature, then to convert it to a lower temperature compared with water at the same temperature, the following formula should be used:²

$$\text{Sp.gr. Substance at } t_1/t_1 = \text{Sp.gr. Substance at } t_2/t_2 \times \text{Sp.gr. Water at } t_2/t_1 + k(t_2 - t_1).$$

In both of the above formulae, the following values may be taken approximately for *k*, representing the coefficient of expansion per ° F.

Creosote oil from coal tar	0.00044
Residual oil	0.00040
Coal tar	0.00038
Coke-oven tar	0.00033
Semi-solid asphalt	0.00030
Semi-solid coal-tar pitch	0.00030

¹ "Specific Gravity—Its Determination for Tars, Oils and Pitches," by J. W. Weiss, loc. cit.

² For the Specific gravity of water at varying temperatures, see Bureau of Standards, Circular No. 19, p. 43, Mar. 30, 1916.

The pycnometer method may also be used for finding the specific gravity of hard and brittle bituminous substances, including hard asphalts of high fusing-point, asphaltites, asphaltic pyrobitumens, non-asphaltic pyrobitumens and pyrobituminous shales. Approximately 3.5 grams of the material ground to 60-mesh are carefully weighed and introduced into a 50-c.c. pycnometer, with about 30 c.c. of distilled water. A vertical condensing bulb is attached to the pycnometer with a small section of rubber tubing, the open end being connected with an aspirator to maintain a partial vacuum. The pycnometer is then boiled on a water bath to expel all the air from the sample. The inside of the condensing tube is then washed back into the pycnometer, which is cooled to the desired temperature, stoppered, filled to the mark with water at the same temperature and weighed. The specific gravity may then be calculated from the following formula:

$$\frac{(c-a)}{(b-a)-(d-c)}$$

Where a represents the weight of the pycnometer empty, b its weight filled with water, c its weight containing the bituminous substance, and d its weight containing the bituminous substance also filled to the mark with water.¹

Test 7d. Sommer Hydrometer Method. This method is adapted to readily fusible semi-solid to solid bituminous substances. The apparatus is illustrated in Fig. 155 and consists of the small metal cup a holding exactly 10 c.c., a sleeve b threaded on the inside so that it may be attached to the top of the cup, the cover c and the threaded flange d . The cup with the sleeve screwed in place is filled with the melted bituminous substance, and heated a short time slightly above its fusing-point to release any air bubbles or traces of moisture. The cup is then allowed to cool to 77° F., and the sleeve unscrewed. If the bituminous material is hard, the sleeve should first be warmed with a Bunsen burner. The bituminous material extending over the cup is cut off and levelled with a hot knife, the cover and flange fastened in place, and the specific gravity determined by suspending the cup from the special hydrometer illustrated. The specific gravity is read directly and is accurate to the third decimal place.²

Test 7e. Hubbard Pycnometer Method. This method is similarly adapted to semi-solid or solid bituminous materials melting under the influence of heat. The pycnometer is illustrated in Fig. 156 (A and B) which shows two approved forms. It consists of a fairly heavy straight-walled glass tube, 70 mm. long and 22 mm. in diameter, having a neck ground to receive a glass stopper provided with a vertical opening running through its entire length, having a mark etched to indicate a capacity of 24–25 c.c. The bituminous material is melted and carefully poured into the dry pycnometer filling it about half full. After cooling to 77° F. it is weighed, then filled with water to the mark and reweighed. The specific gravity may be calculated from the formula given under test 7c (procedure for testing solid bituminous materials).³

¹ "Methods of Analyzing Coal and Coke," Technical Paper No. 8, Bureau of Mines, Wash., D. C., p. 37, 1913.

² "A New Method and Apparatus for the Determination of the Specific Gravity of Semi-solid Substances," by Albert Sommer, *Proc. Am. Soc. Testing Materials*, **9**, 602, 1909.

³ Bulletin No. 314, U. S. Dept. of Agriculture, Wash., D. C., p. 5; "Laboratory Manual of Bituminous Materials," by Hubbard, p. 34, 1916; "Methods for Testing Coal Tars and Refined Tars, Oils and Pitches Derived Therefrom," by S. R. Church, *J. Ind. Eng. Chem.*, **3**, 228, 1911; **5**, 195, 1913.

Test 7f. Weiss' Specific Gravity Pan Method. This method is both rapid and convenient, being adapted principally to semi-solid or solid bituminous products. The pan as illustrated in Fig. 157 is made of platinum or nickel and weighs about 7 grams. Its dimensions are as follows: diameter of base 20 mm., diameter of top

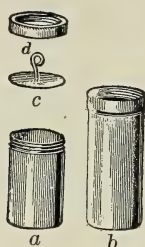

Courtesy of Eimer & Amend.

FIG. 155.—Sommer Hydrometer.



Courtesy A. H. Thomas Co.

FIG. 156.—Hubbard Pycnometer.



From A. S. T. M. Standards.

FIG. 157.—Weiss Specific Gravity Pan.

25 mm., depth 12 mm., diameter of wire 1 mm. The melted bituminous material is poured into the pan without taking particular care to fill it to any prescribed point. It is fastened to a waxed silk thread, weighed in air and then in water at 77° F., by suspending it from the arm of a balance. The specific gravity may be calculated in the following formula:

$$\frac{(c-a)}{(b+c)-(a+d)}$$

Where a represents the weight of the pan in air, b its weight in water, c its weight plus the bituminous substance in air, and d its weight plus the bituminous material in water.

The pan may be readily cleaned after the test by warming it over a burner and pouring out as much of the bituminous substance as possible, then removing the balance with a solvent, and finally igniting it.¹

Test 8. Viscosity. This test is of value in determining the adaptability of the bituminous substance for a given purpose, for gauging the uniformity of supply, and for factory control work. It is used particularly for examining liquid to semi-liquid substances for road purposes, and may also be used to good advantage for predetermining the ability of semi-solid substances to saturate fabrics at elevated temperatures.

Test 8a. Engler Method. The Engler viscosimeter is illustrated in Fig. 158, consisting of a cylindrical vessel a , 105-6 mm. in diameter, with a cover b and a convex bottom, opening into a platinum-lined tube c , 20 mm. long, 2.9 mm. in diameter at the top, and 2.8 mm. at the bottom. The orifice may be opened or closed with the wooden plunger d . Metal projections are fastened to the inside of the vessel 25 mm. from the lowest portion of the cylindrical side-walls and 32 mm. from the upper opening of the orifice. These serve to control the volume of bituminous liquid introduced, which amounts to exactly 240 c.c. The bituminous material is maintained at any desired temperature by the heating-bath consisting of water, glycerine or cotton-seed oil in the cylindrical jacket f , heated by the ring-burner h , and the temperature recorded by the thermometer e . The out-flow of 200 c.c. of distilled water at 68° F. is carefully observed. If the apparatus has been constructed properly, this will require 50-52 seconds.

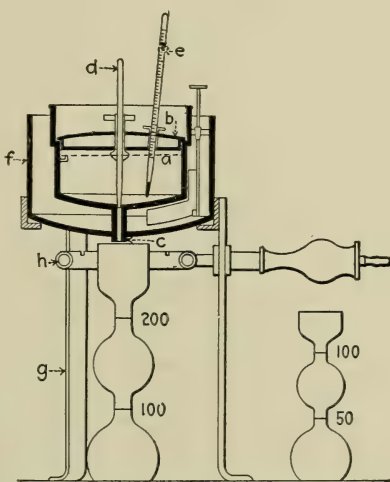

FIG. 158.—Engler Viscosimeter.

The bituminous material is ordinarily tested at 77° F. (25° C.), 172° F. (50° C.), or 212° F. (100° C.) depending upon its consistency. The viscosimeter is filled to the top of the points with bituminous material, brought to the required temperature, and the time noted for 200, 100, 50 or 20 c.c. to flow through the orifice. If 100 c.c. are allowed to flow through the instrument, the reading should be multiplied by 2.35 to calculate the time of flow for 200 c.c. If 50 c.c. are allowed to flow through, the reading should be multiplied by 5, and with 20 c.c. by 11.95 to obtain the time of flow for 200 c.c. These factors are constant. The specific viscosity at

¹ "Specific Gravity—Its Determination for Tars, Oils and Pitches," by J. M. Weiss, *J. Ind. Eng. Chem.*, **7**, 26, 1915; *Am. Soc. Testing Materials, Standards*, p. 41, 1917.

t° F. compared with water at 68° F. is equal to the number of seconds for 200 c.c. of the substance to pass through at t° F. divided by the seconds for 200 c.c. of water to pass through at 68° F. Tables have been worked out showing the factor to be used when the apparatus is filled with smaller volumes of liquid, allowing different amounts to flow through.¹

Test 8b. Hutchinson's Tar Tester. This is illustrated in Fig. 159. It was invented by John Hutchinson² and consists of a metal spindle 9 in. long over all, bearing a conical-shaped disc (C) 2 in. in diameter midway between the ends, with a plumb-shaped weight fastened to its lower end. The instrument is supplied with

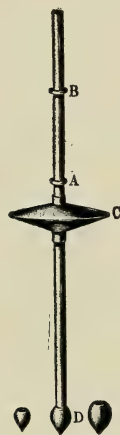
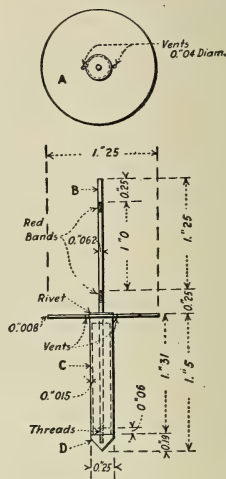

FIG. 159.—Hutchinson's Tar Tester.



From A. S. T. M. Proc.
FIG. 160.—Hubbard's Consistency Tester.

three poises (D) to be used with tars of different consistency or gravity. The spindle bears two rings (A) and (B), 2 in. apart.

The test is conducted by placing the bituminous material in a cylinder at least 9 in. high and 4 in. in diameter, filled to $\frac{1}{2}$ in. of the top. The bituminous material is brought to exactly 77° F., the tester introduced, and the time noted for the spindle to sink from *a* to *b*. Poise No. 1 is recommended for tars having a specific gravity of 1.170–1.195, No. 2 from 1.195–1.215, and No. 3 from 1.215–1.240. The poises do not conform to standard weights or dimensions, and the instrument should not therefore be regarded as a strictly scientific one. It is used extensively in England.³

Test 8c. Hubbard's Consistency Tester. This is an improvement over the Hutchinson Tar Tester, and is illustrated in Fig. 160. It is composed of a circular aluminium disc *A* fastened to a narrow aluminium rod *B*, also to a hollow aluminium rod *C*, of greater diameter, the upper end being made solid except a small

¹ Bulletin No. 314, U. S. Dept. of Agriculture, Wash., D. C., p. 7, 1915; "Untersuchung der Kohlenwasserstofföle und Fette," by D. Holde, Berlin, p. 136, 1913.

² Eng. Pat. No. 22,042 of 1911.

³ "A New English Tar Tester," *Good Roads*, 3, 337, 1912.

hole, large enough to allow the entry of the rod *B*, which is turned and threaded at the bottom and screwed into a conical aluminium weight *D* having a 0.1875 in. taper. The disc *A* carries 2 holes 0.04 in. in diameter, placed at opposite sides, 0.145 in. from the centre. The upper end of the rod *B* carries two scale markings, one 0.25 in., and the other 1.25 in. above the disc *A*. The bottom of the rod *B* is filled with lead dust until the instrument weighs exactly 2.8 g. The bituminous substance is first brought to 77° F. and introduced into a jacketed cylinder, with a hemi-spherical bottom, 3¼ in. deep, and 2 in. in diameter. The tester is then introduced, recording the time required to sink below the surface of the bituminous material from the lower to the upper marking on the rod *B*.

A fairly constant ratio is claimed to exist between the results obtained with this tester and the Engler viscosity (i.e., introducing 240 c.c. into the instrument and noting the time of flow in seconds at 77° F. for 50 c.c. of the bituminous

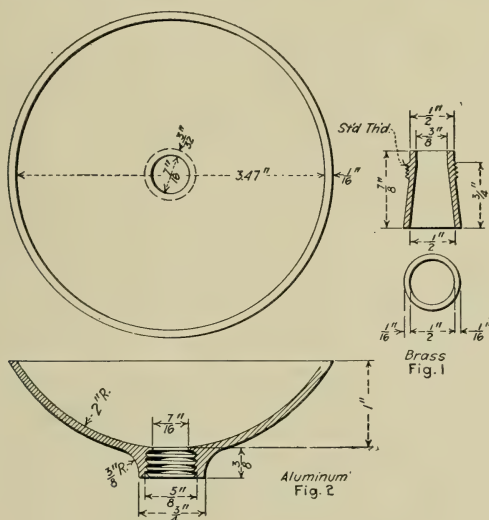

FIG. 161.—Float Tester.

material, divided by the time for 50 c.c. of water). An Engler viscosity of 60 corresponds to approximately 2 seconds on the Hubbard instrument, an Engler viscosity of 120 to approximately 4 seconds, and the Engler viscosity of 240 to approximately 8 seconds at 77° F.¹

Test 8d. Float Test. This instrument is used largely for testing the viscosity or consistency of semi-solid bituminous materials used for road purposes. The range of the float test is limited, and it cannot be used with very fluid bituminous materials or with hard solids. It accordingly fills the gap between the Engler viscosimeter and the Hubbard consistency tester on one hand, and the needle penetrometer and consistometer on the other. The test is not affected by the presence of mineral matter or free carbon.

The instrument is illustrated in Fig. 161. It consists of two parts, viz.: an aluminium saucer-shaped float, and a conical brass collar weighing exactly 50 g.

¹ "A New Consistency Tester for Viscous Liquid Bituminous Materials," by Prévost Hubbard and F. P. Pritchard, *Proc. Am. Soc. Testing Materials*, **17**, 605, 1917.

together. The brass collar is filled with melted bituminous material upon placing it against a brass plate, the surface of which has been amalgamated by treatment with a dilute solution of mercuric nitrate and then with mercury. After cooling, it is levelled, placed in water at 41° F. for 15-30 minutes along with the aluminium float, and then screwed into the float and immediately floated on the surface of water warmed to the desired temperature, with the brass collar downward. No standard temperature has been adopted for making this test, although 90° F. is recommended as the most satisfactory in testing road binders, for which the instrument is intended. Very soft materials are tested at 32° F., and hard bituminous substances at 122° F. or 150° F.

As the heat is transmitted through the brass collar into the plug of bituminous material, the latter softens until it is forced upward and out of the collar by the weight of the instrument. The time elapsing between the placing of the float on the surface of the water, and when the water breaks through the plug is taken as a measure of the viscosity of the material under examination. The author has also found the float test of value for testing bituminous substances at a temperature *exactly* 50° F. higher than the fusing-point by the B. and R. method, thereby furnishing a criterion of the susceptibility to temperature changes (see p. 501), also a means of distinguishing between blown and residual asphalts (p. 293).¹



Courtesy of A. H. Thomas Co.

FIG. 162.—Schutte Viscosity Tester.

Test 8e. Schutte Consistency Tester. This instrument, as illustrated in Fig. 162, operates similarly to the float tester, with the difference, however, that the pressure is applied by a column of water above the plug of pitch. The melted bituminous material is first introduced into a brass collar 1 in. high and $\frac{5}{8}$ in. in diameter. This is placed in water at the required temperature for at least 10 minutes, and then screwed into the tube ($10\frac{3}{8}$ in. long). The apparatus is immersed

in water maintained at the required temperature so the water level just covers the lower shoulder of the tube, which is then completely filled with water at the given temperature, and the time interval recorded between the filling of the tube and the displacement of the plug of bituminous material at the bottom. Check tests are said to agree within 5 seconds.²

Test 9. Hardness or Consistency. This constitutes one of the most important tests for examining bituminous materials, and is employed for purposes of identification, considered either alone or in conjunction with the fusing-point; for determining the adaptability of bituminous materials in connection with certain proposed uses; for gauging the

¹ "Controlling the Consistency of Bituminous Binders," by C. N. Forrest, *Eng. Rec.*, 59, 584, 1909; *J. Ind. Eng. Chem.*, 1, 378, 1909; "Tentative Methods for Analysis of Creosote Oil" (Serial Designation: D 48-17 T) of the Am. Soc. Testing Materials A. S. T. M. *Tentative Standards, proposed in 1917*; *Proc. Am. Soc. Testing Materials*, 17, Vol. I, 826, 1917.

² "Methods for Testing Coal Tar and Refined Tars, Oils and Pitches Derived Therefrom," by S. R. Church, *J. Ind. Eng. Chem.*, 3, 229, 1911.

uniformity of supply; and for purposes of factory control. The Moh's hardness scale is intended for the hardest bituminous materials, whereas the needle penetrometer and the consistometer have a range of usefulness from semi-solids to moderately hard solids.

Test 9a. Moh's Hardness Scale. This test has long been used for recording the hardness of minerals by comparing their resistance to abrasion with substances of known hardness. Ten minerals are used in a graduated scale of units, viz.: (1) talc, (2) gypsum, (3) calcite, (4) fluorite, (5) apatite, (6) orthoclase, (7) quartz, (8) topaz, (9) sapphire and (10) diamond. A pointed fragment of the standard mineral is moved back and forth several times on the same line, a short distance across the surface of the bituminous material under test. If the bituminous material is not scratched, it is harder than the mineral used, whereas if it is scratched, it may be either softer or of the same hardness as the standard mineral. If it is of the same hardness, it will in turn scratch the surface of the standard mineral but if it is softer, it will have no effect. The first four standard minerals are used for this purpose, as the hardest bituminous materials encountered usually do not test higher than 4 on Moh's scale.

Test 9b. Needle Penetrometer. This was originally devised by H. C. Bowen in 1888.¹ This first crude instrument was further improved by A. W. Dow.² The Dow penetrometer as simplified in construction by Richardson and Forrest represents the type in use to-day,³ both forms operating on the same principle and giving the same readings.

The Richardson-Forrest improved penetrometer is illustrated in Fig. 163. The base *A* may be levelled by the thumb screws *B*, and is attached to the standard *C* and also the platen *D*, which by means of a screw-shank raises or lowers the revolving disc *E*, on which is placed the sample of bituminous material to be tested. The standard *C* carries a bracket *F* adjustable as to elevation by a thumb-screw, also the bracket *G*, which on the back carries the clock-work *H* timing the duration of the test by half-second beats, and on the front the dial *J* divided into 360 degrees, with the hand *K*, marking the number of degrees, each of which represents one-tenth millimeter of penetration measured by rack on sliding gauge *L*, engaging in pinion on the shaft which actuates the hand *K*. The bevelled-edge mirror *N* adjustable through universal joints, serves to reflect light on the sample under test. The plunger *O* acts as a brake, which holds the needle bar, representing a weight of 50 g. together with the superincumbent weight in place, until pressed inward, which movement permits the needle and weight to act upon test-block without friction, and is easily operated by grasping the horns *Q* between two fingers and

¹ *S. of M. Quarterly*, 10, 297, 1889; U. S. Pat. 494,974 of Apr. 4, 1893 to H. C. Bowen; "Report of the Operations of the Engineer Department of the District of Columbia," p. 106, for 1889-90; also article by Clifford Richardson in *Eng. Record* of Oct. 31, 1891.

² "Report of the Engineer Dept. of the District of Columbia, for year ending June 30, 1898," p. 127, "Report of the Inspector of Asphalt and Cement of the District of Columbia for the year ending June 30, 1901," p. 158, by A. W. Dow; "Testing of Bitumens for Paving Purposes," by A. W. Dow, *Proc. Am. Soc. Testing Materials*, 3, 354, 1903; "Relation between Some Physical Properties of Bitumens and Oils," by A. W. Dow, *Proc. Am. Soc. Testing Materials*, 6, 497, 1906.

³ "The Development of the Penetrometer as Used in the Determination of the Consistency of Semi-Solid Bitumens," by Clifford Richardson and C. N. Forrest, *Proc. Am. Soc. Testing Materials*, 7, 626, 1907; "A Further Development of the Penetrometer as Used in the Determination of the Consistency of Semi-Solid Bitumens," by C. N. Forrest, *Proc. Am. Soc. Testing Materials*, 9, 600, 1909.

pressing the brake-head *O* with the thumb. *M* represents a weight of predetermined capacity, either 50 or 150 g. A form of penetrometer operated by an electrical timing device has also been constructed.¹ A miniature penetrometer for portable use is illustrated in Fig. 164.

Careful investigations have been made as to the diameter of the holder for the bituminous material;² the method of preparing the specimen;³ the size and shape of the needle;⁴ also other variable factors.⁵ As a result of these, the following standard test has been adopted.⁶

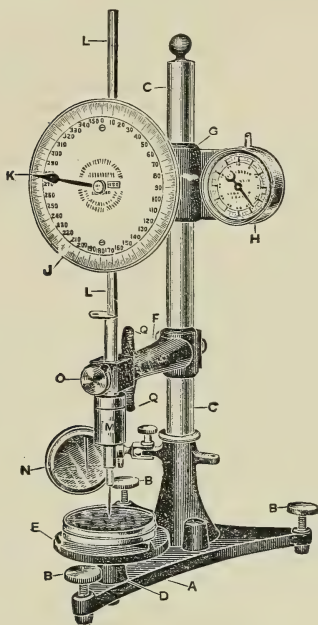

Courtesy of Howard & Morse.

FIG. 163.—Penetrometer.

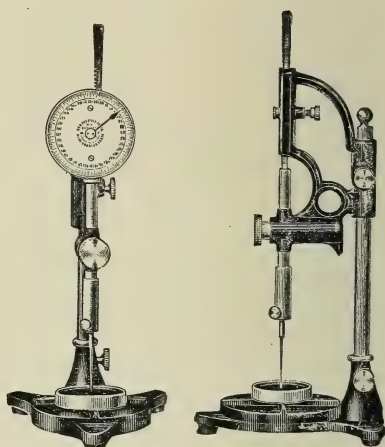

Courtesy of Howard & Morse

FIG. 164.—Miniature Penetrometer.

"Penetration is defined as the consistency of a bituminous material, expressed as the distance that a standard needle vertically penetrates a sample of the material under known conditions of loading, time and temperature. Where the conditions of test are not specifically mentioned, the load, time and temperature are under-

¹ U. S. Pat. 512,687 of Jan. 16, 1894 to A. W. Dow and T. R. Griffith; H. W. Mahr, *J. Ind. Eng. Chem.*, **6**, 133, 1914.

² "Effect of Diameter of Bitumen Holder on the Penetration Test," by C. S. Reeve, *Proc. Int. Assoc. Testing Materials*, Sixth Congress, N. Y., XXV-3, 1912.

³ *Proc. Am. Soc. Testing Materials*, **16**, Part I, 306, 1916; "Revised Standard Test for Penetration of Bituminous Materials," by L. W. Page, *Chem. Eng. Manuf.*, **24**, 32, 1916.

⁴ "A New Penetration Needle for Use in Testing Bituminous Materials," by C. S. Reeve and F. P. Pritchard, *J. Agric. Research*, **5**, 1121, 1916.

⁵ "Effect of Controllable Variables on the Penetration Test for Asphalts and Asphalt Cements," by Prévost Hubbard and F. P. Pritchard, *J. Agric. Research*, **5**, 805, 1916.

⁶ "Standard Test for Penetration of Bituminous Materials" (Serial Designation: D 5-16), *A. S. T. M. Standards Adopted in 1916*, 530.

stood to be 100 g., 5 seconds and 77° F. respectively, and the units of penetration to indicate hundredths of a centimeter.

"The container for holding the material to be tested shall be a flat-bottom cylindrical dish, 55 mm. ($2\frac{1}{8}$ in.) in diameter and 35 mm. ($1\frac{3}{8}$ in.) deep. The needle for this test shall be a cylindrical steel rod 50.8 mm. (2 in.) long, having a diameter of 1.016 mm. (0.04 in.) and turned on one end to a sharp point having a taper of 6.35 mm. ($\frac{1}{4}$ in.). The water bath shall be maintained at a temperature not varying more than 0.2° F. from 77° F. The volume of water shall not be less than 10 litres, and the sample shall be immersed to a depth of not less than 10 cm. (4 in.) and shall be supported on a perforated shelf of not less than 5 cm. (2 in.) from the bottom of the bath. Any apparatus which will allow the needle to penetrate without appreciable friction and which is accurately calibrated to yield results in accordance with the definition of penetration, will be acceptable. The transfer-dish for container shall be a small dish or tray of such capacity as will insure complete immersion of the container during the test. It shall be provided with some means which will insure a firm bearing and prevent rocking of the container. The sample shall be completely melted at the lowest possible temperature and stirred thoroughly until it is homogeneous and free from air bubbles. It shall then be poured into the sample container to a depth of not less than 15 mm. ($\frac{3}{8}$ in.). The sample shall be protected from dust and allowed to cool in an atmosphere not lower than 65° F. for 1 hour. It shall then be placed in the water bath along with the transfer dish and allowed to remain 1 hour.

"In making the test, the sample shall be placed in the transfer dish, filled with water from the water bath at sufficient depth to completely cover the container. The transfer dish containing the sample shall then be placed upon the stand of the penetration machine. The needle, loaded with specified weight, shall be adjusted to make contact with the surface of the sample. This may be accomplished by making contact of the actual needle-point with the image reflected by the surface of the sample from a properly placed source of light. Either the reading of the dial shall then be noted, or the needle brought to zero. The needle is then released for the specified period of time, after which the penetration machine is adjusted to measure the distance penetrated.

"At least three tests shall be made at points on the surface of the sample not less than 1 cm. ($\frac{3}{8}$ in.) from the side of the container, and not less than 1 cm. apart. After each test the sample and transfer dish are returned to the water bath and the needle shall be carefully wiped towards its point with a clean dry cloth to remove all adhering bituminous matter. The reported penetration shall be the average of at least three tests whose values shall not differ more than 4 points between maximum and minimum. When desirable to vary the temperature, time and weight, and to provide for uniform method of reporting results when such variations are made, the sample shall be melted and cooled in air as above directed. It shall then be immersed in water or brine, as the case may require, for 1 hour at the temperature desired. The following combinations are suggested:

32° F.; 200 g. weight; 60 seconds,
77° F.; 100 g. weight; 5 seconds,¹
115° F.; 50 g. weight; 5 seconds."

¹Inserted by author. Not included in the printed method published by the Am. Soc. Testing Materials.

The principal shortcoming of the needle penetrometer is the fact that the readings at various temperatures (115, 77 and 32° F. respectively) must be expressed on *different* scales, and are therefore not comparable. It is difficult and in many cases impossible to interpret the *extent* of the physical change from the range in readings, upon subjecting a bituminous substance to variations in temperature. In addition, the scope of the penetrometer is limited, as it will not answer for either semi-liquid or hard bituminous materials. These objections are overcome in the consistometer.

Test 9c. Consistometer. This instrument is constructed according to scientific principles, and may accurately be duplicated at any time. It registers the degrees hardness on a scale ranging from 0 to 100, and may be used for determining the hardness of substances as soft as vaseline (which will test 0.3 at 77° F.) to substances as hard as gilsonite (testing in the neighborhood of 100 at 77° F.). In all cases, the hardness or consistency is expressed as the cube root of the number of grams which must be applied to a circular flat surface 1 sq.cm. (100 sq.mm.) in area, to cause it to displace the substance at a speed of 1 cm. per minute. Readings for all bituminous substances and at all temperatures (whether 115, 77 or 32° F.) are expressed on a *single* scale. The harder the substance, the greater will be its hardness expressed numerically.

Four mushroom-shaped plungers are used, each having a round flat head with a reduced shank, so the perimeter of the penetrating surface forms a "knife" edge. This entirely eliminates the fractional adhesion of the bituminous substance to the sides of the plungers. The flat heads of the plungers are made in the following dimensions:

Plunger	Diameter in mm.	Area in sq.mm.
No. 1.....	1.13	1
No. 10.....	3.57	10
No. 100.....	11.28	100
No. 1000.....	35.67	1000

The method of testing consists in forcing one of the plungers into the substance at a *uniform* speed of 1 cm. per minute. The force is automatically registered in grams or kilograms. For any plastic substance, the number of grams required to effect this displacement is directly proportional to the *volume* displaced. The volumes displaced per minute by the respective plungers are 0.1, 0.10, 1.00 and 10.0 c.c. respectively. The relation between the plungers is therefore in the direct proportion of 1:10:100:1000.

For the sake of uniformity, all readings are expressed in terms of the number of grams applied to plunger No. 100 (1 sq.cm.). In other words, the readings obtained with plunger No. 1000 are divided by 10, those obtained with plunger No. 10 are multiplied by 10, and those obtained with plunger No. 1 are multiplied by 100. The hardness or consistency is equal to the cube root of this number of grams.

Two interchangeable springs are supplied, one registering in grams on a scale ranging 0 to 1000 g., in 10 g. divisions, and the other for reading in kilograms on a scale ranging from 0 to 10 kgs., in 0.1 kg. divisions. In using plungers No. 1 and No. 10, the kilogram spring only should be employed. In using plunger No. 100 either the gram or the kilogram spring may be employed, depending upon the

hardness of the material. In using plunger No. 1000, the gram spring *only* should be employed. The relations are expressed in the following table:

Plunger.	Spring.	Actual Reading.	Converted to grams per 100 sq.mm. Plunger.	Cube Root grams Applied 100 sq.mm. Plunger.
1000 sq.mm.	G.	{ From 10 g.	1	1.00
		{ to 1000 g.	100	4.64
100 sq.mm.	G.	{ From 100 g.	100	4.64
		{ to 1000 g.	1,000	10.00
10 sq.mm.	Kg.	{ From 1.0 kgs.	1,000	10.0
		{ to 10.0 kgs.	10,000	21.5
1 sq.mm.	Kg.	{ From 1.0 kg.	10,000	21.5
		{ to 10.0 kgs.	100,000	46.4
1 sq.mm.	Kg.	{ From 1.0 kg.	100,000	46.4
		{ to 10.0 kgs.	1,000,000	100.0

Table XXXVI shows the relation between the consistometer readings and degrees hardness, bearing in mind that in every case the hardness is designated as the cube root of the number of grams applied to the No. 100 plunger (area 100 sq.mm.), to cause it to displace the substance at a speed of 1 cm. per minute.

The consistometer is illustrated in Fig. 165. It is first levelled by the four screws *A*. The spring *B* is then attached, selecting the gram spring for soft substances, or the kilogram spring for hard substances. The steel shaft *C* is inserted and screwed firmly into place. The plunger *D* should then be screwed into the lower end of the shaft. Plunger No. 1 is used for hard and brittle substances, plunger No. 10 for moderately hard solid substances, plunger No. 100 for moderately soft semi-solid substances, and plunger No. 1000 for semi-liquid substances.

The scale *E* is graduated in grams on one side, and kilograms on the other, and is reversible. It should be attached so that the graduations will correspond with the spring used, and adjusted so the indicator *F* will rest at the 0 division. The maximum indicator *G* is also brought to the 0 division using the small instrument *H*.

The bituminous substance is melted at the lowest possible temperature and poured into a small receptacle as described for the needle penetration method. The tin box *J* containing the bituminous substance is then supported underneath the machine in a vessel of water (not shown) maintained at the temperature at which the test is to be performed. The pressure is applied to the plunger by turning the hand-wheel *O*, and the speed of displacement

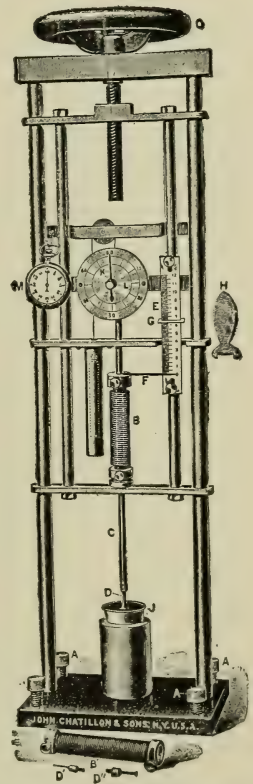

FIG. 165.—Consistometer.

TABLE XXXVI
FOR CONVERTING CONSISTOMETER READINGS INTO POINTS HARDNESS.

PLUNGER No. 1000 (1000 sq. mm.)—GRAM SPRING.

Grams Applied	0	10	20	30	40	50	60	70	80	90
0	0.00	1.00	1.26	1.44	1.59	1.71	1.82	1.91	2.00	2.08
100	2.15	2.22	2.29	2.35	2.41	2.47	2.52	2.57	2.62	2.67
200	2.71	2.76	2.80	2.84	2.88	2.92	2.96	3.00	3.04	3.07
300	3.11	3.14	3.17	3.21	3.24	3.27	3.30	3.33	3.36	3.39
400	3.42	3.45	3.48	3.50	3.53	3.56	3.58	3.61	3.63	3.66
500	3.68	3.71	3.73	3.76	3.78	3.80	3.83	3.85	3.87	3.89
600	3.91	3.94	3.96	3.98	4.00	4.02	4.04	4.06	4.08	4.10
700	4.12	4.14	4.16	4.18	4.20	4.22	4.24	4.25	4.27	4.29
800	4.31	4.33	4.34	4.36	4.38	4.40	4.41	4.43	4.45	4.46
900	4.48	4.50	4.51	4.53	4.55	4.56	4.58	4.59	4.61	4.63

PLUNGER No. 100 (100 sq. mm.)—KILO SPRING

100	4.64	4.79	4.93	5.07	5.19	5.31	5.43	5.54	5.65	5.75
200	5.85	5.94	6.04	6.13	6.21	6.30	6.38	6.46	6.54	6.62
300	6.69	6.77	6.84	6.91	6.98	7.05	7.11	7.18	7.24	7.31
400	7.37	7.43	7.49	7.55	7.61	7.66	7.72	7.775	7.83	7.88
500	7.94	7.99	8.04	8.09	8.14	8.19	8.24	8.29	8.34	8.39
600	8.43	8.48	8.53	8.57	8.62	8.66	8.71	8.75	8.79	8.84
700	8.88	8.92	8.96	9.00	9.045	9.09	9.13	9.17	9.21	9.24
800	9.28	9.32	9.36	9.40	9.44	9.47	9.51	9.55	9.58	9.62
900	9.65	9.69	9.73	9.76	9.80	9.83	9.86	9.90	9.93	9.97

PLUNGER No. 100 (100 sq. mm.)—KILO SPRING

Kilos Applied	0.0	0.1	0.2	0.3	0.4	0.5	0.6	0.7	0.8	0.9
1.0	10.0	10.3	10.6	10.9	11.2	11.4	11.7	11.9	12.2	12.4
2.0	12.6	12.8	13.0	13.2	13.4	13.6	13.75	13.9	14.1	14.3
3.0	14.4	14.6	14.7	14.9	15.0	15.2	15.3	15.5	15.6	15.7
4.0	15.9	16.0	16.1	16.3	16.4	16.5	16.6	16.75	16.9	17.0
5.0	17.1	17.2	17.3	17.4	17.5	17.65	17.8	17.9	18.0	18.1
6.0	18.2	18.3	18.4	18.5	18.6	18.7	18.8	18.85	18.95	19.0
7.0	19.1	19.2	19.3	19.4	19.5	19.6	19.7	19.75	19.8	19.9
8.0	20.0	20.1	20.2	20.25	20.3	20.4	20.5	20.6	20.65	20.7
9.0	20.8	20.9	20.95	21.0	21.1	21.2	21.25	21.3	21.4	21.5

PLUNGER No. 10 (10 sq. mm.)—KILO SPRING

1.0	21.5	22.2	22.9	23.5	24.1	24.7	25.2	25.7	26.2	26.7
2.0	27.1	27.6	28.0	28.4	28.8	29.2	29.6	30.0	30.4	30.7
3.0	31.1	31.4	31.7	32.1	32.4	32.7	33.0	33.3	33.6	33.9
4.0	34.2	34.5	34.8	35.0	35.3	35.6	35.8	36.1	36.3	36.6
5.0	36.8	37.1	37.3	37.6	37.8	38.0	38.3	38.5	38.7	38.9
6.0	39.1	39.4	39.6	39.8	40.0	40.2	40.4	40.6	40.8	41.0
7.0	41.2	41.4	41.6	41.8	42.0	42.2	42.4	42.5	42.7	42.9
8.0	43.1	43.3	43.4	43.6	43.8	44.0	44.1	44.3	44.5	44.6
9.0	44.8	45.0	45.1	45.3	45.5	45.6	45.8	45.9	46.1	46.3

PLUNGER No. 1 (1 sq. mm.)—KILO SPRING

1.0	46.4	47.9	49.3	50.7	51.9	53.1	54.3	55.4	56.5	57.5
2.0	58.5	59.4	60.4	61.3	62.1	63.0	63.8	64.6	65.4	66.2
3.0	66.9	67.7	68.4	69.1	69.8	70.5	71.1	71.8	72.4	73.1
4.0	73.7	74.3	74.9	75.5	76.1	76.6	77.2	77.75	78.3	78.8
5.0	79.4	79.9	80.4	80.9	81.4	81.9	82.4	82.9	83.4	83.9
6.0	84.3	84.8	85.3	85.7	86.2	86.6	87.1	87.5	87.9	88.4
7.0	88.8	89.2	89.6	90.0	90.45	90.9	91.3	91.7	92.1	92.4
8.0	92.8	93.2	93.6	94.0	94.4	94.7	95.1	95.5	95.8	96.2
9.0	96.5	96.9	97.3	97.6	98.0	98.3	98.6	99.0	99.3	99.7
10.0	100.0	100.3	100.7	101.0	101.3	101.6	102.0	102.3	102.6	102.9

controlled by following the pointer *K*, on the dial *L*, which should be caused to revolve at the same speed as the second hand of a chronometer *M*, conveniently suspended alongside. The numbers on the dial *L* correspond with those of the second hand on the chronometer. One revolution of the pointer *K* indicates that the plunger has moved downward exactly one centimeter.

At the termination of 60 seconds, after the pointer on the dial has made one revolution, the pressure on the plunger is relieved. The reading of the maximum indicator *G* on the scale *E* is then noted, and the corresponding degree of hardness ascertained by referring to the table.

When the plunger commences to displace the substance at the specified speed of 1 cm. per minute, a maximum reading is obtained which should remain constant throughout the entire displacement. The consistometer is simple to operate, gives closely concordant results, expresses the readings obtained at all temperatures on one scale and has a sufficiently great range to include all bituminous substances ordinarily encountered.¹

Test 9d. Susceptibility Factor. This factor is a numerical expression representing the susceptibility of a bituminous substance to temperature changes. The more susceptible the material the higher will be its "susceptibility factor." It is calculated from the consistometer hardness and the K. and S. fusing-point (Test 15a) in the following manner:

$$\text{Susceptibility Factor} = \frac{(\text{Hd at } 32^{\circ} \text{ F.}) - (\text{Hd at } 115^{\circ} \text{ F.})}{\text{Fusing-point, K. and S. Method}} \times 100$$

This factor is useful as a means of identification; for predetermining the adaptability of the substance for certain usages; gauging its uniformity of supply; and for purposes of factor control. This factor bears no relation to the hardness or fusing-point, and is substantially constant for bituminous substances derived from the same source or produced by the same general process. In the case of blown petroleum asphalts, it furnishes an indication of the *extent* to which the substance has been blown; the further the process having been continued, the smaller the factor expressed numerically. With residual asphalts derived from any one crude, the susceptibility factor will remain constant, regardless of the extent to which the distillation has progressed.

By means of the susceptibility factor, bituminous materials may be roughly divided into the following groups, viz.:

Susceptibility Factor under 40: Includes blown petroleum asphalts, fatty-acid pitches and fluxed asphaltites (having a factor between 8 and 40); also wurtzilite asphalts (having a factor between 30 and 40).

Susceptibility Factor between 40 and 60: Includes residual asphalts.

Susceptibility Factor over 60: Includes mineral waxes, pitches derived from tars, and asphaltites (of which the susceptibility factor varies from 75 to over 100).

Native asphalts have been excluded from the foregoing groups, since their susceptibility factors vary widely, ranging from 15 to greater than 100. The author has never examined a bituminous material having a susceptibility factor lower than 8.²

¹ "Improved Instruments for the Physical Testing of Bituminous Materials," by Herbert Abraham, *Proc. Am. Soc. Testing Materials*, **9**, 568, 1909; **11**, 676, 1911; U. S. Pat. 989,471 of Apr. 11, 1911 to Herbert Abraham.

² "Improved Instruments for the Physical Testing of Bituminous Materials," by Herbert Abraham, *Proc. Am. Soc. Testing Materials*, **11**, 683, 1911.

Test 10. Ductility. This represents the capacity of the bituminous material for elongating or stretching. The test is of value for identifying the bituminous substance, for indicating its adaptability in connection with certain usages, for gauging its uniformity of supply, and for purposes of factory control. The ductility test often enables us to differentiate between blown petroleum asphalts and native or residual asphalts. Most pitches derived from tars are extremely ductile, but fatty-acid pitches are variable in this respect. The ductility test is useful for predetermining the adaptability of bituminous materials for paving purposes, for adhesive compounds to be used in connection with waterproofing or built-up roofing work, and for manufacturing surface coatings of prepared roofings. Wherever the bituminous material is subjected to extensive changes in temperature or vibration, it is important that it should have high ductility within the particular temperature range to which it will be subjected. With every bituminous substance there exists a certain temperature, usually within 10 to 30° F. of its fusing-point (K. and S. method), at which the ductility attains a maximum. A ductility curve constructed for any bituminous substance over a range of temperature assumes the same form as the probability curve in higher mathematics. It is desirable that the maximum ductility should coincide as closely as possible with the *average* temperature to which the material is to be subjected.

There are two methods in use, depending upon the construction of the moulds, namely one devised by A. W. Dow, and one proposed by the author.

Test 10a. Dow Ductility Test. The Dow mould is constructed of four brass parts as illustrated in Fig. 166, and of the following dimensions: external length 9 cm., internal length 7.5 cm., distance between the ends of clips 3.0 cm., extreme internal width of mould 3.0 cm., internal width at mouth of clips 2.0 cm., internal cross-section half-way between clips 1.0 cm., and thickness of briquette 1.0 cm.¹

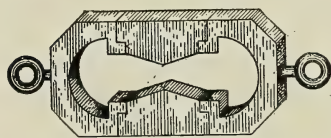

Courtesy of Humboldt Mfg. Co.
FIG. 166.—Dow Ductility Mould.

The two centre pieces should be well amalgamated to prevent the bituminous material from adhering, and the mould assembled on an amalgamated brass plate. The bituminous material is melted at the lowest possible temperature, poured in a steady stream into the centre of the mould, and a slight excess added to allow for shrinkage on cooling. The mould is cooled in air and levelled off with a hot spatula. The two centre pieces are then removed, leaving the briquette of bitumi-

¹ "The Testing of Bitumens for Paving Purposes," by A. W. Dow, *Proc. Am. Soc. Testing Materials*, **3**, 352, 1903; "Report of the Commissioners of the Dist. of Columbia, for the year ending June 30, 1904," p. 42; "Methods for Testing Asphalt," by A. W. Dow, *Chem. Eng.*, **1**, 330, 1905; "Tests of Asphalts for Paving Purposes," by A. W. Dow and F. P. Smith, *Munic. Eng.*, **40**, 437, 1911.

nous material held at either end by the clips, and carefully transferred to a vessel of water maintained within 1 degree of the required temperature for at least 1, but not longer than 2 hours. The clips should then be pulled apart under water maintained within 1 degree of the required temperature, at a uniform rate of speed of 5 cm. per minute. The line of pull should be horizontal or nearly so, and the separation effected without appreciable vibration. Three tests should be averaged.¹

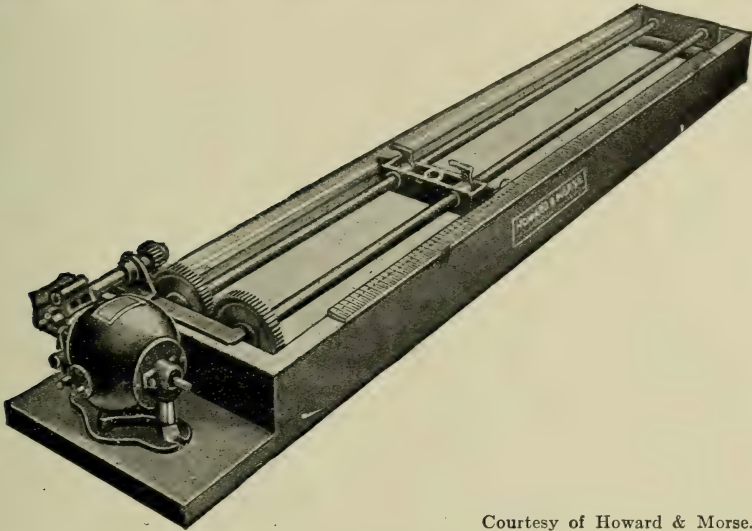

Courtesy of Howard & Morse.

FIG. 167.—Smith Ductility Machine.

It is customary to make this test at three temperatures, viz.: 115, 77 and 32° F. Various machines have been proposed for this purpose, including the one devised by Smith, illustrated in Fig. 167.²

An instrument with a dynamometer attachment adapted to use the Dow mould, measuring both the ductility and "cementitiousness" (tensile strength) has been described by Lester Kirschbraun.³ This device is essentially the same as that which had been previously described by the author in 1910. (See test 10b).

Test 10b. Author's Ductility Test. An improved mould designed by the author, is illustrated in Fig. 168 and shown in cross-section in Fig. 169. It consists of two cylindrical sections constructed of hardened steel, resting together on circular knife-

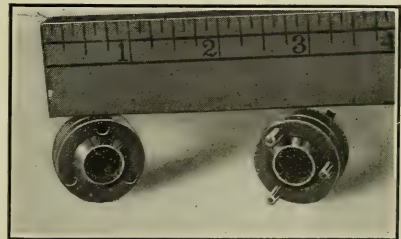

FIG. 168.—Author's Ductility Mould.

¹ "Report of Sub-Committee on Ductility Tests," *Proc. Am. Soc. Testing Materials*, Part I, 15, 349, 1915.

² "Machine for Testing the Ductility of Bituminous Paving Cements," by F. P. Smith, *Proc. Am. Soc. Testing Materials*, 9, 594, 1909.

³ "The Cementing Value of Bituminous Binders," by Lester Kirschbraun, *J. Ind. Eng. Chem.*, 6, 976, 1914; U. S. Pat. 1,180,506 of Apr. 25, 1916.

edges and maintained in that position by three guide pins. It is filled by unscrewing the upper cap and pouring in the melted bituminous substance, which on cooling forms a prismoid, whose altitude is 2.5 cm., the end-areas 1.8 cm. in diameter, with a minimum cross-section at the centre of exactly 1.0 sq.cm. (1.28 cm. in diameter). The upper cap is screwed in place, the mould fastened in the tensometer and the two halves separated at the uniform speed of 5 cm. per minute. The elongation in cms. at the moment the material parts is a measure of its ductility.¹

This mould has a number of advantages over the Dow type, including its adaptability to testing semi-liquid and semi-solid bituminous materials, no amalgamation is necessary, there is no danger of the material breaking in the mould upon being

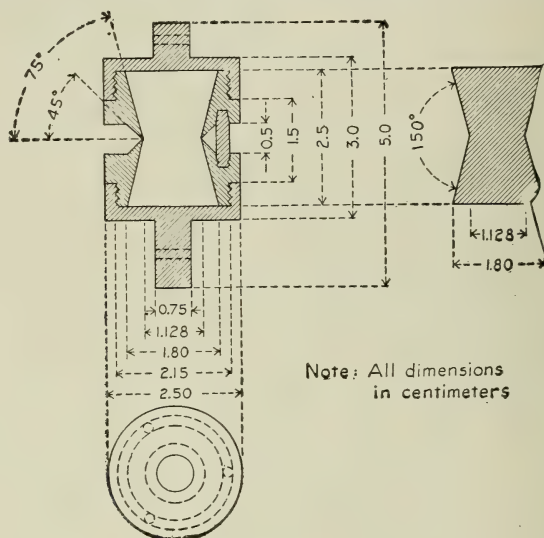

FIG. 169.—Cross-section Author's Mould.

cooled to the proper temperature, the personal equation is eliminated in filling the mould with the assurance that the minimum cross-section will be *exactly* the proper size, and only a small quantity of the material is required in making the test.

The tensometer is illustrated in Fig. 170. The two sections of the mould A-1 and A-2 are clamped between the guides B-1 and B-2, the lower section being fastened to the stationary cross-piece C by the pin D-1, and the upper section to the movable cross-head E by the pin D-2. The cross-head is attached to the chain F which passes over the sprocket-wheel G fastened to the dynamometer H, and then around a suitable winding mechanism I. The specimen is drawn apart by turning the hand-wheel J which operates the endless chain K running on the sprocket wheels L-1 and L-2. The dynamometer is equipped with a trigger M to prevent recoil. The chain F also connects with a train of gears operating the brass pointer N pressing against the dial O which is formed of vulcanite or some other insulating

¹ "Improved Instruments for the Physical Testing of Bituminous Materials," by Herbert Abraham, *Proc. Am. Soc. Testing Materials*, 10, 444, 1910; 11, 679, 1911.

material. Its face is marked in one hundred divisions, each consisting of a metallic contact. As the pointer brushes over these contacts it momentarily closes an

electric circuit which operates the relay *P*, causing a "click." The relay is connected with the batteries *Q* and the switch *R*. One revolution of the pointer indicates that the halves of the mould have been separated a distance of exactly one meter, and a movement of the pointer over one division of the dial corresponds to a centimeter rise in the section *A-2*.

The guides *B-1* and *B-2* are pivoted at *S-1* and *S-2*, which permits the glass reservoir *T* being slipped into place, whereupon they are locked into position by the bolt *U*. The reservoir is filled with water maintained at the desired temperature by the heating coil *Y* in series with the incandescent lamps *V*. The bath may be agitated upon squeezing the bulb *W*, which forces air through the liquid. The valve *X* is for emptying the reservoir. The speed is controlled by a metronome with a bell attachment set to ring every 12 seconds, or 5 times per minute. The speed with which the crank is turned must be regulated so that the "clicks" of the relay are brought into unison with the rings of the metronome.

The reservoir should be filled with a liquid having about the same specific gravity as the bituminous material tested, so the thread of material will neither have a tendency to float nor sink while the moulds are being separated. The operator must watch the specimen as sections *A* and *B* separate, and he should cease turning the crank at the moment the thread parts. The dynamometer indicates the tensile strength of the substance in kilograms (Test 11), and the dial *O* its ductility in centimeters. The substance is usually tested at 115, 77 and 32° F.

Test 11. Tensile Strength by the Author's Method. This is recorded on the tensometer

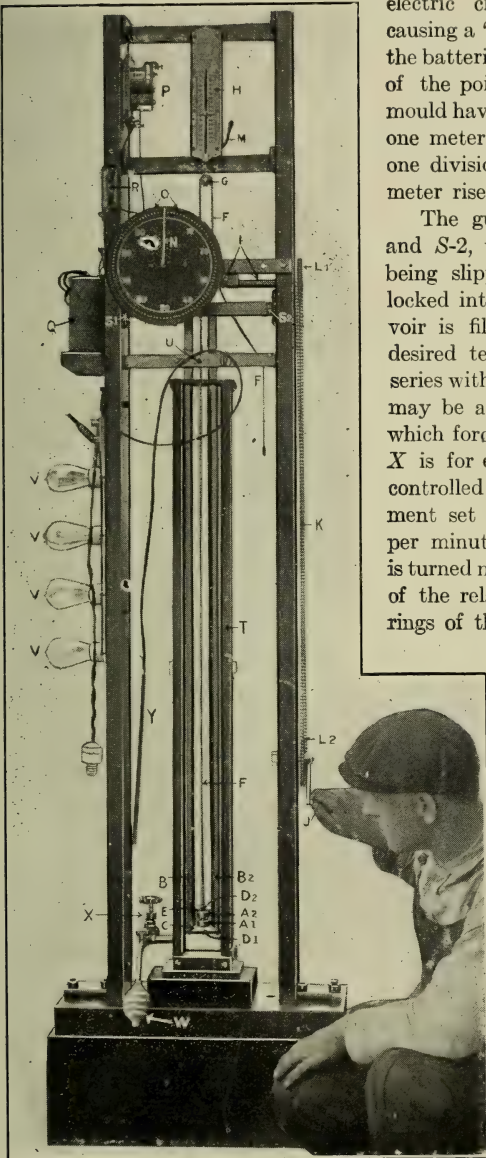

FIG. 170.—Tensometer.

as described in Test 10*b*, and is equal to the maximum reading in kilograms as the two halves of the mould separate. It is a measure

of cohesiveness or cementitiousness and is of value in determining the adaptability of a bituminous substance for certain definite purposes, especially for paving, manufacturing adhesive compounds for waterproofing and built-up roofing work, bituminous substances for electrical insulation, moulded articles, pipe joints, etc. The tensile strength is ordinarily tested at 115, 77 and 32° F. For each bituminous substance, there is a critical temperature at which the tensile strength tests a maximum, and this is generally coincident with the temperature at which the ductility approaches 0. This phenomenon may be explained by the disappearance of plasticity and associated cohesiveness at temperatures when the substance becomes transformed into a brittle solid. The tensile strength curve is also similar in form to the probability curve in higher mathematics. There appears to be no definite relation between the hardness and tensile strength of bituminous substances. With residual asphalts manufactured from the same crude, the tensile strength is reduced after the distillation progresses beyond the hard and brittle stage. Excessive blowing produces the same results, but to a lesser degree.

Test 12. Adhesiveness Test. This test serves as a measure of the adhesiveness of the bituminous material, and it is of primary importance in ascertaining its adaptability for certain definite usages, as, for example, in road building, preparing compounds for water-proofing and built-up roofing work, cements, etc. It represents the capacity of the substance to adhere to solid objects with which it may be brought in contact, and differs entirely from the cohesiveness or tensile strength referred to in Test 11. Various instruments have been proposed for this purpose including those devised by Fulweiler,¹ Osborne, Kirschbraun and others.

Test 12a. Osborne Adhesive Test. This is designed especially for measuring the adhesion of semi-liquid to semi-solid road oils suitable for the construction of carpet or seal coats (p. 367).

The apparatus is illustrated in Fig 171 and is composed of two concentric cylinders. The stationary inner cylinder is hollow and measures exactly 1.995 in. in diameter. It is maintained at 77° F., by a stream of water circulating through it, entering and leaving by the horizontal tubes shown to the right, one bearing a thermometer to register its temperature. The movable outer cylinder or collar, 2.000 in. in diameter and 2 in. wide is caused to revolve on the inner cylinder with a uniform layer of the bituminous material to be tested in between, by being wound with a cord attached to a 3 kg. weight. The thin film of bituminous material between the cylinders offers a resistance of this turning, and the adhesive

¹ "A New Machine for Testing Pitch," by T. Y. Olsen, *Proc. Am. Soc. Testing Materials*, **10**, 592, 1910; "Impact Testing Machine for Pitch," by W. H. Fulweiler, *Am. Assoc. Adv. Sci.*, Wash., D. C., 1911; "Good Roads," **3**, 81, 1912.

value is measured by recording the length of time required for three complete revolutions of the collar.¹ Table XXXVII includes tests reported by the designer of the machine, the float test having been ascertained at 90° F. (Test 8*d*), and the viscosity by the Engler viscosimeter at 212° F. (Test 8*a*).



Courtesy of C. B. Osborne.

FIG. 171.—Osborne Adhesive Tester.

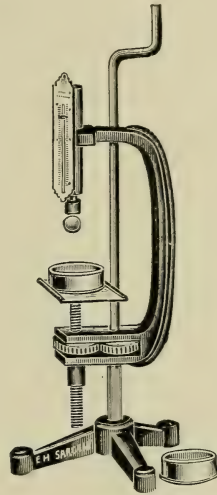

Courtesy of E. H. Sargent Co.

FIG. 172.—Kirschbraun Adhesive Tester.

Test 12b. Kirschbraun Adhesive Test. This is designed for testing semi-solid to solid bituminous materials. The instrument is constructed as illustrated in Fig. 172, consisting of a dynamometer with a maximum-reading indicator having a ball attached to its lower end. A platform with side clips for holding the container of the bituminous material is attached to a threaded bar, geared to a crank for raising or lowering the sample. The container is provided with side flanges by which it is held on the platform. The bituminous material is poured into the cup so as to enclose the ball, and when cooled to the desired temperature, the platform is lowered at a uniform speed until the ball withdraws from the specimen under test. The adhesion is recorded by the dynamometer.

¹ Private communication from Clarence B. Osborne of the California Highway Commission, Sacramento, Cal.

TABLE XXXVII

Sp.gr. at 77° F. Test 7).	Solubility in Carbon Disulphide (Test 21a)	Flash-point °F. (Test 17)	Burning Point °F. (Test 18)	Float Test at 90° F. (Test 8d)	Viscosity Test at 212° F. (Test 8a)	Osborne Adhesive Test at 77° F. (Test 12a)	Loss in 5 Hours 325° F. (Test 16)	Float Test at 90° F. a'ter 5 Hours at 325° F.	% Asphalt (of 80 Penetra- tion at 77° F.) at 400° F.	Hours Heated at 400° F.
0.998	99.74	339	460	390	1312	690	2.68	1113	92.0	9.0
0.935	99.78	216	290	72	427	26	15.37	8055	80.0	3.5
1.001	99.83	277	415	186	584	281	3.48	706	89.1	8.5
0.979	99.91	325	450	93	334	40	3.24	149	86.2	25.0
0.971	99.90	280	355	29	143	5.5	8.01	86	75.6	32.0
0.932	99.93	360	525	187	591	208	0.90	234	92.5	30.0
0.973	99.86	29	129	6.2	12.58	132	70.2	8.0
0.997	99.90	330	420	143	438	125	1.71	225	87.7	14.0
0.996	99.46	651	1573	1,006	0.17	1019	95.5	14.0
0.993	99.94	146	481	119	4.28	315	86.0	10.0
.....	132	413	80
0.995	99.85	280	946	430	3.09	837	91.7	10.0
0.990	99.78	135	443	73	2.43	217	81.3	14.0
0.992	99.78	350	426	130	430	99	4.43	292	84.2	14.0
0.993	99.77	340	428	141	436	110	5.22	368	84.7	14.0
0.998	99.77	181	566	197	1.94	284	90.2	19.0
0.986	99.96	358	480	132	474	141	2.31	214	89.0	20.0
0.984	99.88	444	528	230	724	409	0.27	289	93.0	26.0
0.996	99.95	345	418	133	414	112	5.81	379	85.0	10.0
0.998	99.82	428	518	420	1238	450	0.36	538	94.0	4.5
0.991	99.83	318	410	136	419	104	4.19	277	85.0	13.0
1.027	99.59	304	420	1702	4090	3,960	3.88	115*	92.9	3.0
0.991	99.85	315	405	201	630	315	4.2	591	88.0	8.0
0.984	99.92	320	522	212	727	313	0.6	302	92.3	20.0
0.992	99.91	280	474	147	425	90	2.3	259	88.5	12.0
0.997	99.90	310	418	151	552	161	5.9	496	85.5	7.0
1.007	99.69	250	400	575	2108	590	6.5	89.6	3.0
0.997	99.95	335	428	249	882	218	5.2	720	88.3	6.0
0.992	99.73	235	365	316	1370	9.0	136*	87.0	3.0
0.996	99.96	360	440	454	873	710	1.4	839	90.6	7.0
1.012	99.84	385	494	8490	8342	20,880	1.5	76*	97.2	1.5
0.994	99.77	385	470	308	709	670	2.2	570	88.2	15.0
0.984	99.93	315	525	208	666	310	0.5	226	92.2	28.0
0.986	99.65	420	530	849	900	928	0.6	887	95.0	13.0
1.017	99.84	380	470	147*	9213	10,710	1.7	85*	97.0	2.5
0.991	99.90	405	525	429	925	520	1.0	95.2	20.0
0.998	99.94	210	260	2.8	88.0	11.5
0.997	99.86	320	487	92.0	7.5
1.006	99.67	380	480	142*	8015	15,600	97.8	1.5
0.989	99.93	315	398	137	445	164	84.2	17.0
1.021	99.80	375	485	140*	8220	22,500	98.1	1.5
0.995	99.78	150	150	86.9	13.0

* Penetration at 77° F.

CHAPTER XXIX

HEAT TESTS

Test 13. Odor on Heating. This test serves as a valuable guide for identifying bituminous materials. The following substances in particular may be recognized when present in the pure state or in admixture with other substances, by their characteristic odor evolved upon heating.

Oil-gas-tar Pitch, Water-gas-tar Pitch and Coal-tar Pitches: Odor, acrid, sharp and penetrating.

Wood-tar Pitches: Odor somewhat similar to that of coal-tar pitches, also characteristic but less sharp and intense.

Fatty-acid Pitches: Odor sweetish and bland, also characteristic.

Asphalts (including native and pyrogenous asphalts): Odor oily and some cases slightly sulphurous.

Gilsonite: Odor characteristic but cannot very well be described in words.

Test 14. Subjection to Heat. Certain bituminous substances behave in a characteristic manner upon subjecting them to the influence of heat, which also assists in their identification.

Test 14a. Behavior on Melting. Some bituminous materials pass rapidly from the solid to the liquid state on heating, as for example the mineral waxes, most of the native asphalts, residual asphalts, sludge asphalts, peat-tar pitch, lignite-tar pitch, oil-gas-tar pitch, water-gas-tar pitch, and the coal-tar pitches. On the other hand, many bituminous materials, especially those of a low susceptibility factor (Test 9d) melt sluggishly, and pass through an intermediate "pasty" stage; as for example blown petroleum asphalt, wurtzilite asphalt, asphaltites and the saponifiable fatty-acid pitches. The same is manifested by any bituminous materials containing large proportion of mineral matter, also those which have been sulphurized. Capp and Hull have devised a method for depicting this graphically.¹

Test 14b. Behavior on Heating in Flame. This test is especially useful for hard and solid bituminous materials, and constitutes a rapid method for distinguishing between those which are fusible and infusible. Fusible bituminous substances, including the mineral waxes, asphalts, asphaltites and pitches will behave in one of the following ways: they may simply soften and flow, as proves to be the case with mineral waxes, asphalts, gilsonite, glance pitch and the true pitches. If moisture is present, these substances will decrepitate. Grahamite acts in a characteristic manner, those varieties showing a hackly fracture, soften, split and

¹"A Method for Studying the Effects of Temperature upon the Physical Condition of Asphalts, Waxes, etc.," by J. A. Capp and F. A. Hull. *Proc. Am. Soc. Testing Materials*. **17**, 627, 1917.

burn in the flame, whereas those showing a conchoidal fracture decrepitate violently even when no moisture is present.

The asphaltic pyrobitumens also behave in characteristic manners. They will not fuse in the flame, but when dry, act as follows: elaterite and wurtzilite burn quietly, albertite intumescens, whereas impsomite decrepitates.

Test 15. Fusing ("Melting") Point.¹ This constitutes one of the most valuable all-around tests. It is used for purposes of identification, especially with materials fusing at a high temperature, such as the asphaltites, and is particularly useful in this connection upon taking into consideration the specific gravity and hardness. It is also used for ascertaining the adaptability of a bituminous material for certain definite usages, including its resistance to the sun or artificial heat. The fusing test serves to gauge the uniformity of supply, and on account of its rapidity and accuracy, is used extensively for purposes of factory control. Several methods have been proposed for this purpose, viz.:

Test 15a. Kramer-Sarnow Method. This method is rapid, accurate, and adapts itself either to soft or hard bituminous materials, from residual oils up to grahamite. Its range is greater than that of any other fusing-point method.

It was first proposed by G. Kramer and C. Sarnow.² Various modifications have been suggested from time to time.³ The author has made a careful study of this method, and recommends the following procedure:⁴

Substances Fusing below the Boiling-point of Water. This method consists in heating a plug of the bituminous substance 5 mm. long, in an open glass tube, 6-7 mm. internal diameter, and about 8 cm. long, the plug supporting 5 g. mercury, and the tube being immersed in a vessel of water, the level of which reaches approximately the centre of the mercury column. In making the test, a thermometer is suspended in the liquid, so its bulb will be at the same level as the plug of bituminous material. The thermometer is supported in a separate glass tube of the same thickness and diameter as the other tube, but differing therefrom in having its lower end sealed, and containing sufficient mercury to surround the bulb. The water is heated at a uniform rate of 4° F. per minute, and the temperature at which the mercury drops through the plug of bituminous material recorded as its fusing temperature. The tube containing the bituminous substance may have a mark etched 5 mm. from the end, as a convenient guide for the quantity of bitu-

¹ The term "fusing-point" has been used throughout the text in place of the phrase "melting-point," since the former is more expressive of the behavior of fusible bituminous substances under the influence of heat. They pass *gradually* from the solid to the liquid condition, the transition taking place slowly, owing to the heterogeneous character of the substances present. The phrase "melting-point" is more appropriately applied to chemical substances having a definite composition, which melt sharply, and within a narrow temperature range.

² *Chem. Ind.*, **26**, 55, 1903.

³ B. M. Margosches, *Chem. Rev. Fett-Harz-Ind.*, **11**, 277, 1904; M. Wendriner, *Z. angew. Chem.*, **18**, 622, 1905; E. Graefe, *Chem. Zeit.*, **30**, 298, 1906; Bauert, *Chem. Zeit.*, **29**, 382, 1905; Offermann, *Petroleum*, **6**, 2117, 1910; L. Barta, *Petroleum*, **7**, 158, 1911; V. Abeles, *Chem. Zeit.*, **38**, 249, 1914.

⁴ "Improved Instruments for the Physical Testing of Bituminous Materials," by Herbert Abraham, *Proc. Am. Soc. Testing Materials*, **9**, 575, 1909; **11**, 673, 1911.

minous material to be introduced. The plug of bituminous material may be introduced into the tube by inverting it and inserting from its lower end a well-fitting cork or wooden plug fastened to a stiff wire. The mercury is poured on same, and the plug raised or lowered until the meniscus of the mercury coincides with the mark etched on the tube. The bituminous material is then melted at a temperature slightly above its fusing-point and poured on top of the mercury, to completely fill the tube, which should be warmed slightly. When cool, the bituminous material is levelled off even with the end of the tube, whereupon the tube is inverted and the plug withdrawn. This is illustrated in Fig. 173.

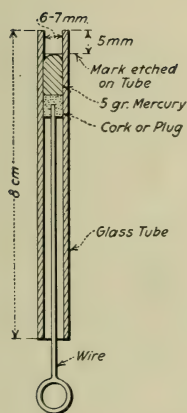

FIG. 173.—Method of Filling K. & S. Fusing-Point Tubes.

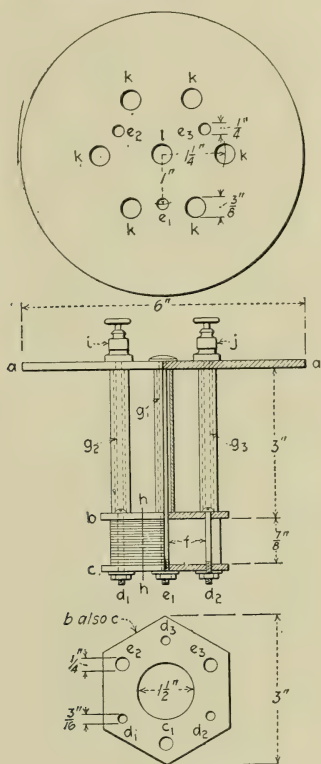

FIG. 174.—Heating Coil for K. & S. Fusing-Point Tester.

The mercury is measured from a heavy-walled capillary tube of 1 mm. bore, terminating in a three-way cock, as illustrated at *j*, Fig. 175, and calibrated to hold exactly 5 g. mercury at room temperature. The short limb of the tube is connected with a movable reservoir containing mercury, the height of which is adjusted so the mercury in the capillary tube exactly reaches the graduation.

The heating is conveniently effected by an electrical device described by the author,¹ illustrated in Fig. 174, composed of a coil of resistance wire to be immersed

¹ *Proc. Am. Soc. Testing Materials*, 9, 577, 1909.

in the liquid bath containing the fusing-point tubes, and connected with a rheostat, by means of which the temperature may be controlled to a nicety. Three slabs of slate or asbestos-cement, *a*, *b* and *c*, are fastened together with three small bronze bolts *d*-1, *d*-2 and *d*-3, also three large bolts, *e*-1, *e*-2 and *e*-3 enclosed in glass tubes *f* and *g* respectively, to prevent short circuiting. The coil *h* consists of 10 yd. of cotton-covered No. 30 nichrome resistance wire wound in a single layer around the tubes, and connected with the bolts *e*-2 and *e*-3, which in turn terminate in binding-posts *i* and *j*. The coil after being assembled is treated with a high-grade insulating

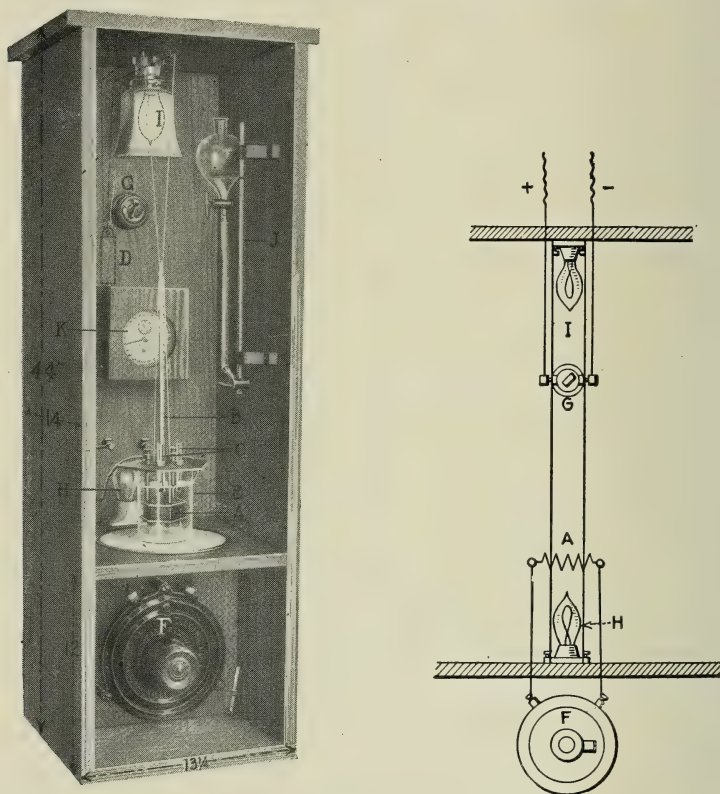

FIG. 175.—K. & S. Fusing-Point Tester.

varnish and baked until hard. Ten holes are drilled in the slab *a*, three *e*, for the large bolts, six *k* for the fusing-point tubes and one *l*, for the thermometer tube. The coil as described offers a resistance of 75 ohms, and allows a passage of approximately 1.5 amperes at a potential of 110 volts. It will raise the temperature of 500 to 600 c.c. of water to the boiling-point in a few minutes, when the full current is applied.

The apparatus is assembled as illustrated in Fig. 175. The heating coil *A* carrying the thermometer *B* and the fusing-point tubes *C* is counterbalanced by the weight *D*, so it may be raised or lowered into the beaker *E* holding 500–600 cc.

of water. The heating coil is connected with a rheostat *F* and a switch *G* in parallel with an 8 c.p. incandescent lamp *H* behind the beaker to illuminate the fusing-point tubes, and a 32 c.p. lamp *I* to light up the interior of the apparatus; *J* represents the mercury measuring-device, and *K* a clock from which the hour hand has been removed, and the dial graduated in 240 divisions representing degrees Fahrenheit. The rise in temperature is synchronized with the minute hand of the clock and controlled by the rheostat to increase *exactly* 4° F. *per minute*. The initial temperature of the water should be at least 25° F. lower than the fusing-point of the material to be examined. Six tests may be run simultaneously.

The heating coil is simple to construct, easy to operate, and insures a perfect temperature control. Owing to its skeleton construction, the heat is rapidly dissipated, and there is no danger of the coil burning out, provided it is kept immersed in the water while the current is on. In the author's laboratory, where the coils are in daily use, they last from 2 to 3 years, and when burnt out, the wiring may be renewed in a few minutes' time.

Substances Fusing above the Boiling-point of Water. In this case the heating is performed by a direct flame, as illustrated in Fig. 176, the water being replaced with castor oil which may be heated safely to about 600° F. This method may be used for determining the fusing-point of asphaltites including grahamite. A small quantity of the high fusing-point bituminous material is powdered and compressed in the lower end of the fusing-point tube, whereupon it is carefully heated above the flame of a burner, until the plug of bituminous material softens and fuses to the tube, which is evidenced by the color changing from a dull to a glossy black. The tube is then stood upright against a block of wood, a snug-fitting glass rod inserted in the upper end, and pressed against the softened bituminous material to compact it into a solid mass 7 to 9 mm. long. On cooling, the plug is then carefully scraped from the lower end of the tube until *exactly* 5 mm. remains, leaving an air space 2 to 4 mm. between the plug and the lower end of the tube. Care should be taken when suspending the fusing-point tube in the heating bath to allow the free space below the plug to remain filled with air, otherwise oil will come in contact with, and prematurely soften the bituminous material. The bath is heated at the uniform speed of 4° F. per minute.¹

Test 15b. Ball and Ring Method. This method has been proposed by the American Society for Testing Materials.² The apparatus is illustrated in Fig. 177, and consists of a "brass ring 15.875 mm. ($\frac{5}{8}$ in.) in diameter, 6.35 mm. ($\frac{1}{4}$ in.) deep, 2.38125 mm. ($\frac{3}{32}$ in.) wall; suspended 25.40 mm. (1 in.) above the bottom of beaker; a steel ball 9.525 mm. ($\frac{3}{8}$ in.) in diameter, weighing between 3.45 and 3.50 g.; a standardized thermometer; a glass beaker of approximately 600 c.c. capacity."

"Carefully melt the sample and fill the ring with the material to be tested. Remove any excess. Place the ball in the centre of the ring and suspend in beaker containing approximately 400 c.c. water at a temperature at least 25° F. lower than the fusing-point of the sample to be tested. Arrange the thermometer bulb within $\frac{1}{2}$ in. of the sample and at the same level. Apply heat *uniformly* over bottom of the beaker in quantity sufficient to raise the temperature exactly 9° F. per

¹"Improved Instruments for the Physical Testing of Bituminous Materials," *Proc. Am. Soc. Testing Materials*, **11**, 674, 1911.

²"Tentative Method for Determination of Softening Point of Bituminous Materials other than Tar Products," (Serial Designation; D 36-167), *Proc. Am. Soc. Testing Materials*, **17**, Part I, 811, 1917.

minute. The rate of heating is *very* important. The softening point is the temperature at which the specimen has dropped 1 in. Separate tests should average within 5° F. For temperatures above 200° F. glycerin should be used instead of water."

The electrical heating coil described in Test 9a may be used to good advantage in the Ball and Ring method, but the length of nichrome wire should be reduced to 6 yd., to provide for the more rapid heating of the bath.

Tests made by the author indicate that the Ball and Ring fusing-points range 15 to 25° F. higher than those obtained by the K. and S. method. This relationship holds true regardless of whether the fusing-point of the material is low or high.

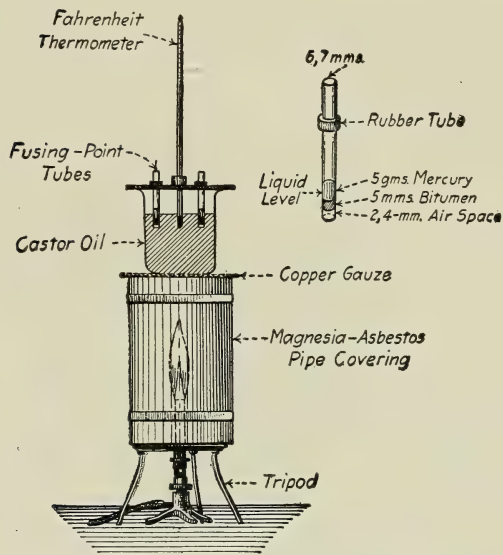
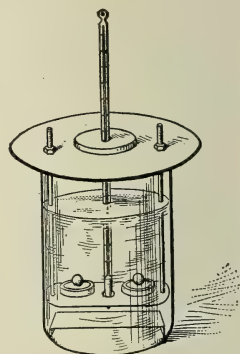

FIG. 176.—K. and S. Tester for High Fusing-Point Substances.



From A. S. T. M. Standards.
FIG. 177.—B. and R. Fusing-Point Tester.

Test 15c. Cube Method. This method is restricted to testing tar-pitches.¹

For Pitches Fusing below 170° F. The following method should be used, with an apparatus as illustrated in Fig. 178. The material is melted by the gentle application of heat until it becomes sufficiently fluid to pour, care being taken that it suffers no appreciable loss by volatilization. It is then poured into the brass mould which has been amalgamated with mercury to prevent it sticking to the sides. After cooling, the cube of bituminous material is levelled, removed from the mould and placed on the hook of No. 12 copper wire as illustrated. It is then suspended in a 600-c.c. beaker containing 400 c.c. water, at least 40° F. lower than the fusing-point of the substance. The bottom of the cube should be 1 in. above the bottom of the beaker, and allowed to remain in it at least 5 minutes before the heat is applied. A sheet of paper weighed down on the bottom will prevent

¹"Methods for Testing Coal Tar, and Refined Tars, Oils, and Pitches Derived Therefrom," by S. R. Church, *J. Ind. Eng. Chem.*, **3**, 230, 1911; **5**, 195, 1913.

the pitch adhering to the beaker when it drops off. Heat is applied in such a manner that the temperature of the water is raised *exactly* 9° F. each minute. The temperature recorded by the thermometer at the instant the cube of pitch touches the bottom of the beaker is taken as its fusing-point.

For Pitches Fusing above 170° F. The heating is performed in an air bath in the apparatus illustrated in Fig. 179. The cube should be suspended in line with the observation windows, and the thermometer bulb brought to the same level. The temperature is raised 9° F. per minute, and recorded by the thermometer when the cube drops 1 in. To make the results obtained by this method correspond approximately with those obtained in water or oil, 12° F. should be added to the observed fusing-point.

Investigations of the relationship between the Cube and the Ball and Ring methods¹ indicate that the results vary considerably, depending largely upon the

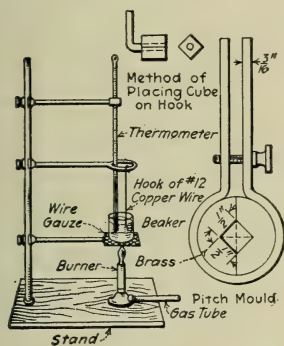

FIG. 178.—Cube Fusing-point Tester.

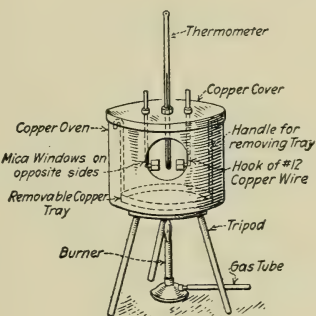

FIG. 179.—Cube Tester for High Fusing-point Substances.

nature of the products tested and their fusing-points. No exact factors can be given. The relation between the fusing-point by the Cube method with the results obtained by the Schutte consistency tester, the Engler viscosimeter and the float test have also been investigated.²

Test 15d. Flowing Temperature. This test has been proposed by Clifford Richardson³ and consists in heating a small cube measuring 1 cu.mm. on a microscopic cover-glass (No. 2-0) floated on the surface of mercury (or solder in the case of the very high fusing-point asphalts or asphaltites), in a deep 3 oz. seamless tin box (American Can Co.) 5.5 cm. in diameter and 3.5 cm. deep, filled to a distance of $\frac{1}{4}$ in. from the top, with mercury or solder. This is covered with an inverted funnel from which the stem has been cut, and a thermometer introduced through the orifice until the bulb is immersed. The heat is increased at the uniform speed of 9° F. per minute, and the temperature recorded when the specimen spreads out in a thin film over the cover-glass. This is designated as its "flowing-point."

¹ "Methods for Determining the Melting-Point of Asphalts," by J. G. Miller and P. P. Sharples, *Proc. Am. Soc. Testing Materials*, **14**, Part II, 503, 1914; "Report of Sub-Committee on Softening Point," *Proc. Am. Soc. Testing Materials*, **15**, Part I, 341, 1915.

² "Relation Between the Melting-Point and the Viscosity of Refined Tars," by P. P. Sharples, *J. Ind. Eng. Chem.*, **6**, 285, 1914.

³ "The Modern Asphalt Pavement," 2nd Edition, 538.

Test 16. Volatile Matter. This test is used for identifying various bituminous materials. Thus in the case of asphalts, the volatilization test will often serve to identify soft native asphalts, which contain larger percentages of volatile matter than soft residual or blown petroleum asphalts. Cut-back products also carry a large percentage of volatile constituents. The test may also be used to determine the adaptability of a bituminous substance for certain definite purposes, where it becomes necessary to heat it to high temperatures, as for example in the paving industry or in manufacturing bituminized roofings and floorings. It likewise serves as a valuable adjunct for gauging the uniformity of supply and for purposes of factory control. It also furnishes an *indication* of the weatherproof properties of the material. Other things being equal, bituminous substances showing the smallest percentage of volatile matter will prove most weatherproof on exposure to the elements. It should be noted, however, that the volatility test alone must not be taken as the final criterion as to whether or not a bituminous substance is weatherproof, since other factors should also be taken into consideration (see p. 345). The volatility test may be regarded as an accelerated test, showing the loss of volatile constituents which will take place upon exposure to the weather in a relatively thin layer, for a long time.

The following method has been proposed by the American Society for Testing Materials.¹

"The amount lost by oils and asphaltic compounds when heated in an oven to 325° F. (within 2° F.), shall be determined by heating 50 g. of the water-free substance (20 g. in the case of tars and pitches) in a flat-bottom dish, the inside dimensions of which are approximately 55 mm. in diameter by 35 mm. deep² for 5 hours.

"The oven in which the substance is to be heated shall be brought to the prescribed temperature before the sample is introduced, and the temperature of the sample under test shall be regarded as that of a similar quantity of the same material immediately adjoining it, in which the bulb of a standardized thermometer is immersed. The oven may either be circular or rectangular in form, and the source of heat either gas or electricity.

"The samples under test shall rest in the same relative position in a single row upon a perforated circular shelf 24.8 cm. (9.75 in.) in diameter, as shown in Fig. 180, suspended by a vertical shaft midway in the oven, which is revolved by mechanical means at the rate of from 5 to 6 revolutions per minute."

The oven ordinarily employed for determining the volatile matter, illustrated in Fig. 181, is composed of a cylindrical vessel with a hinged cover, surrounded by

¹"Standard Test for Loss on Heating of Oil and Asphaltic Compounds," (Serial Designation: D 6-16), of the Am. Soc. Testing Materials, 1916 Book of A. S. T. M. Standards, 533; "Tentative Specifications of Coal-tar Pitch" (Serial Designation, D 42-17 T), *Proc. Am. Soc. Testing Materials*, **17**, Part I, 718, 1917.

² Three-oz. Gill style ointment box, deep pattern, manufactured by the American Can Co.

an insulated jacket, with an air space in between acting as a flue to carry off the hot gases generated by the ring-burner underneath. The oven is equipped with a revolving shelf to support the specimens under examination, and the temperature regulated by a mercury thermostat.

An extension of this test recommended by the author, consists in heating the sample to 500° F. for 4 hours. This is advisable in examining relatively non-volatile asphaltic products, which would show but a fraction of a per cent loss by the foregoing method.

It is customary to find the hardness of the residue after the determination of volatile matter by Method 9b.

Test 17. Flash-point. The flash-point is used primarily for determining the adaptability of bituminous substances for certain definite

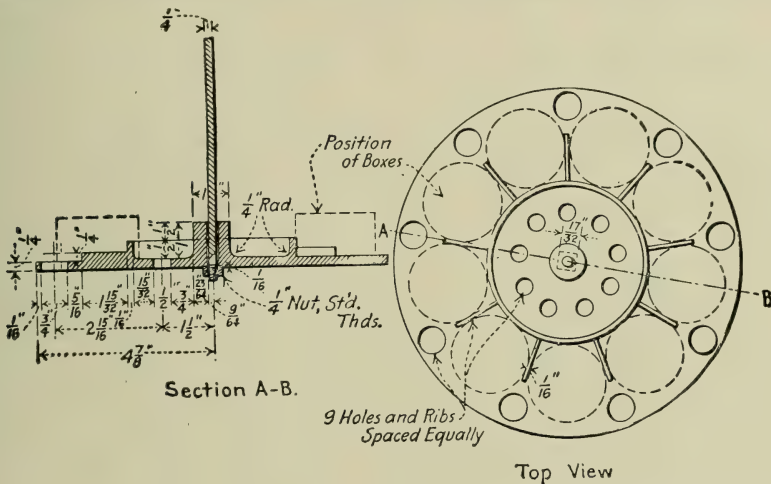

Fig. 180.—Shelf for Volatility Oven.

usages, and serves as a criterion of the fire hazard. It should be at least 50° F. higher than the maximum temperature to which the bituminous substance will be subjected in the process of blending or utilization. This test is also sometimes used for gauging the uniformity of supply and for purposes of factory control.

A number of flash-point testers have been proposed, of which the following are most generally used:

Test 17a. Pensky-Martens Closed Tester. This apparatus has been adopted as standard by the Government of the United States, and foreign governments for testing high flash-point bituminous materials. The instrument is illustrated in Fig. 182, and consists of an oil cup *a*, in a metal heating vessel *b*, surrounded with a flanged top to prevent loss of heat by radiation. An orifice *c* permits the overflow of the oil into the jacket *d* between the oil cup and the heating vessel. It is likewise pro-

vided with a mechanical stirring device *e*, the thermometer *f*, the test flame *g*, burner *i*, wire screen *j*, and spring *k* to work the slide under the test flame.

The approximate flash-point is ascertained by a preliminary test. The melted bituminous substance is poured into the Pensky-Martens tester, which should be perfectly level, taking care not to splash any on the sides of the cup, or to cause any froth on the surface. All bubbles should be pricked with a heated wire. The test flame is then regulated to correspond in size with the ivory bead on the cover (to burn 0.1 cu.ft. coal gas per hour). The burner *i* is lit, and the contents heated rapidly at first until the temperature reaches 50° F. below the expected flash-point, whereupon the rise in temperature should be controlled to increase exactly 5° F. per minute. At each degree the milled head *k* is turned and the flame *g* tilted

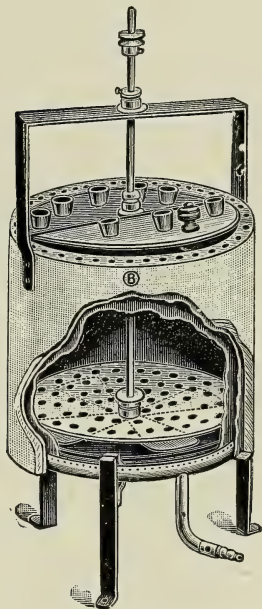

Courtesy of Wm. Boekel & Co.

FIG. 181.—Volatility Oven.

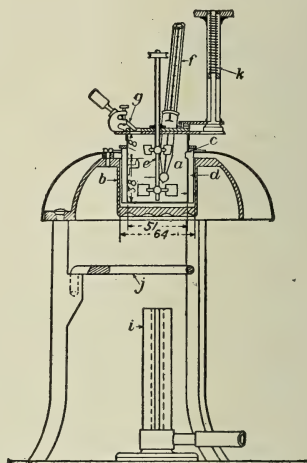

FIG. 182.—Pensky-Martens Closed Flash-point Tester.

into the cup for exactly one second. The test is continued until the flash-point occurs. Any slight flickering or spreading of the flame is ignored. The end point is evidenced by an unquestionable flash. The apparatus should be protected from draughts, and the sample stirred continuously during the test. If the thermometer is graduated to read for total immersion, the stem-correction should be applied. When this is done, it is suggested that "corr." be added to the reading, thus: "Flash 379° F. corr."

A simplified form of Pensky-Martens tester for approximately determining the flash-point, consists of a glass beaker or metal cup having the same dimensions, namely 5.0 cm. in diameter, and 5.5 cm. in depth, filled to within 1.8 cm. of its upper rim with the material to be tested. This is supported on a sand bath and

the thermometer bulb immersed in the bituminous material without, however, touching the sides or bottom. The test flame is adjusted to a 3 mm. cross-section, and the test performed exactly as described for the Pensky-Martens tester.¹

Test 17b. Cleveland Open Tester. This apparatus, illustrated in Fig. 183, consists of a brass cup *a*, holding 100 c.c., supported in an outer vessel *b*, with an air space between. The thermometer *c* is freely suspended in the bituminous material, so the bulb is totally covered. The cup is filled to $\frac{1}{4}$ in. from the top, and the bituminous material heated at the rate of 10° F. per minute. As the flash-point is approached, the test-flame, which should be 5 mm. long, is slowly moved back and forth, so the top of the flame comes 2-3 mm. from the surface of

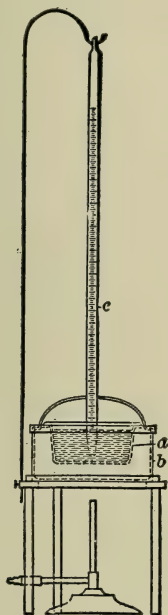

FIG. 183.—Cleveland Open Flash-point Tester.

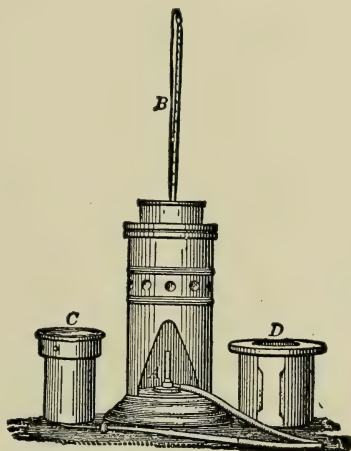

FIG. 184.—New York State Closed Flash-point Tester.

the liquid, without, however, touching it or the sides of the container. This is repeated every 2° F. rise in temperature until the vapors flash.²

Test 17c. New York State or Elliot Closed Tester. This is illustrated in Fig. 184 and consists of a 300-cc. copper container *C*, heated in an oil bath *D*. The cup is provided with a glass cover, carrying the thermometer *B* and a hole for inserting the test-flame, the latter being 5 mm. long. The test is carried out by heating the contents with the burner *A* as in the foregoing, and the rise in temperature carefully regulated to 10° F. per minute.³

¹ "Flash Point of Oils," by I. C. Allen and A. S. Crossfield, Tech. Paper No. 49, Petroleum Technology 10, Dept. of Interior, Bureau of Mines, Wash., D. C., 1913.

² "Laboratory Manual of Bituminous Materials," by Prévost Hubbard, N. Y., 65, 1916.

³ "Petroleum and Its Products," by Boverton Redwood, Volume 2, 577, 1906; "Laboratory Manual of Bituminous Materials," by Prévost Hubbard, N. Y., 66, 1916.

Test 18. Burning-point. The burning-point is used to supplement the flash-point, and is of value in determining the adaptability of bituminous substances for particular purposes, from the standpoint of fire hazard. The test may be performed in any of the apparatus described under flash-point (Test 17). In determining the burning-point, the cover of the tester is removed, and the heating, also exposure to the test-flame continued in the same manner as for the flash-point, until the vapors ignite and continue to burn.

Test 19. Fixed Carbon. This test is used solely for purposes of identification, and is generally restricted to asphaltic products rather than to tars and pitches, since the free carbon in the latter will interfere with the results. Accordingly, if this test is performed on tar products, the free carbon should be ascertained separately (Test 31) and its weight deducted. The percentage of fixed carbon is especially useful in differentiating the asphaltites, the asphaltic pyrobitumens, and the non-asphaltic pyrobitumens.

The test is performed in the following manner:¹ 1 g. of the material is placed in a platinum crucible weighing 20-30 g., having a tightly fitting cover, and heated for exactly 7 minutes, with a Bunsen flame 20 cm. high, the mouth of the burner being 6-8 cm. below the bottom of the crucible. The test should be made in a place free from draughts. The crucible is then transferred to a desiccator, cooled and weighed, whereupon the cover is removed, and the crucible ignited over the full flame of a Bunsen burner, until nothing but ash remains. Any carbon deposited on the cover is also burnt off. The weight of the first residue less the weight of ash gives the weight of fixed carbon, which should be calculated in percentage. If the ash contains carbonates, it should be treated with a few drops of ammonium carbonate solution, and heated a minute or two at red heat, before cooling and weighing.

In the presence of mineral matter, the percentage of fixed carbon should be calculated on the basis of the non-mineral constituents. Mineral matter does not vitiate the results as it merely acts as a diluent. Thus a pure grahamite containing 0.2 per cent mineral matter and 52.22 per cent fixed carbon, when mixed with an equal weight of clay, tested 26.33 per cent, equivalent to 52.7 per cent fixed carbon on the basis of the non-mineral constituents present.

Test 20. Distillation Test. The value of this test is to ascertain the adaptability of bituminous materials for a given use, generally for road treatment; also for gauging the uniformity of supply, for purposes of factory control, and most important of all as a criterion of the quality. This test is generally applied to tar products as an equivalent of the volatility test (Test 16). Two methods are generally employed, one known as the "Flask Method" suitable for bituminous

¹ *J. Am. Chem. Soc.*, **21**, 1116, 1899; "Fixed Carbon in Bituminous Materials, Its Determination and Value in Specifications," by L. Kirschbraun, *Eng. Contr.*, **39**, 172, 1913.

materials intended for road treatment, including both tars and asphaltic products, and another known as the "Retort Method" for testing creosote oil intended for impregnating timber. The bituminous materials must be dehydrated (Test 25), before being subjected to distillation. According to Sharples¹ the distillation test as applied to tars becomes of value in identifying the kind used (upon determining the specific gravity of the fractions distilled), as a means of distinguishing a cut-back tar from a straight-distilled tar (upon determining the specific gravity of the fractions, their viscosity, also the fusing-point of the residue), and for detecting the presence of abnormal amounts of naphthalene.

Test 20a. Flask Method of Distillation. If water is present, the bituminous material must first be dehydrated. This may be conveniently performed by distilling 500 c.c. in an 800-c.c. copper still, provided with a water-cooled condenser, the distillate being caught in a 200-c.c. separatory funnel. When all the water is expelled, the distillate is allowed to settle, the water drawn off and the oils returned to the residue in the still after the contents have cooled below 212° F.

The apparatus as assembled is illustrated in Fig. 185. It consists of 250-c.c. Engler distilling flask of the following dimensions: diameter of bulb 8.0 cm.; length of neck 15.0 cm.; diameter of neck 1.7 cm.; surface of material to lower side of tubulature 11.0 cm.; length of tubulature 15.0 cm.; diameter of tubulature 0.9 cm.; angle of tubulature 75°; with a permissible variation of 3 per cent from the foregoing measurements.

The condenser tube shall have the following dimensions: adapter 70 mm.; length of straight tube 185 mm.; width of tube 12-15 mm.; width of adapter end of tube 20-25 mm.

A carefully standardized thermometer should be used.² The cylinder used for collecting the distillate shall have a capacity of 25 c.c. and be graduated in 0.1 c.c. The burner should be provided with a tin shield 20 cm. long by 9 cm. in diameter, having a small hole for observing the flame. The thermometer bulb should be placed opposite the middle of the tubulature. Pour 100 c.c. of the dehydrated bituminous material into the Engler flask and weigh. Then commence to distil at the rate of 1 c.c. per minute, changing the receiver as the mercury column passes the following fractioning points, reporting the fractions by weight and by volume:

Start to 110° C.; 110-170° C.; 170-235° C.; 235-270° C.; 270-300° C.; and residue.

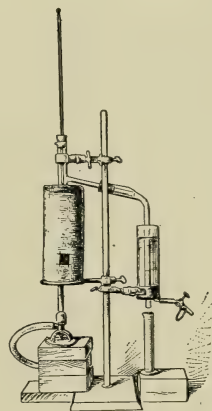

From A. S. T. M. Standards,

FIG. 185.—Flask Method of Distillation.

¹ "Distillation of Tar," *J. Ind. Eng. Chem.*, **5**, 466, 1913.

² *Proc. Am. Soc. Testing Materials*, **17**, Part I, 474, 1917.

The residue is weighed after the distillation is completed and the flask cooled.¹

Test 20b. Retort Method of Distillation. This method is adapted principally for analyzing creosote oils suitable for impregnating timber.² The distillation is performed in a glass retort, having a capacity of 250–290 c.c. (measured by placing the retort with the bottom of the bulb and the end of the offtake in the same horizontal plane and pouring water into the bulb through the tubulature until it overflows through the offtake). The length of the offtake should be 25–30 cm., its internal diameter next to the bulb approximately 2.85 cm., and the diameter at the open end approximately 1.25 cm. The diameter of the tubulature should be approximately 1.9 cm.

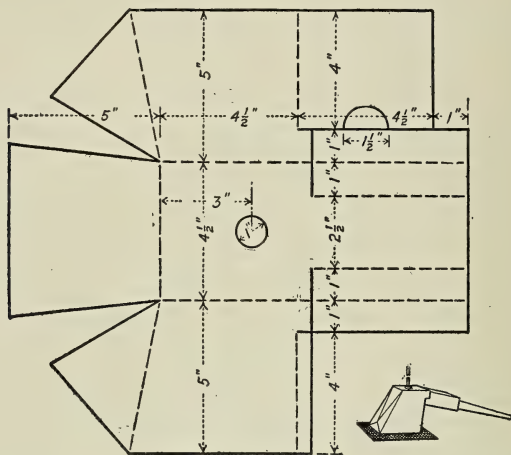

From A. S. T. M. Standards.

Fig. 186.—Asbestos Shield for Retort.

The condenser tube shall have the following dimensions: diameter of small end 12.5 mm. with a variation of 1.5 mm.; diameter of large end 28.5 mm. with a variation of 3.0 mm.; length 360 mm. with a variation of 4.0 mm.

The asbestos shield for the retort shall have the form and dimensions illustrated in Fig. 186. The receiver shall consist of Erlenmeyer flasks of 50–100 c.c. capacity, and the thermometer shall be carefully standardized.³

The apparatus is assembled as illustrated in Fig. 187. Exactly 100 g. of dehydrated creosote oil are distilled at the rate of not less than 1, nor more than 2 drops per second, the distillate being collected and weighed in the receiver. The condenser tube should be warmed whenever necessary to prevent the accumulation of solid distillate, and the receiver changed as the mercury passes the dividing temperatures of the following fractions: 210, 235, 270, 315 and 355° C. When the temperature

¹ "Standard Method for Distillation of Bituminous Materials Suitable for Road Treatment," (Serial Designation; D 20-16) 1916 Book of A. S. T. M. Standards, 540.

² "Standard Method for Sampling and Analysis of Creosote Oil" (Serial Designation; D 38-17) A. S. T. M. Standards Adopted in 1917, 30.

³ "Standard Methods for Sampling and Analysis of Creosote Oil" (Serial Designation; D 38-17) A. S. T. M. Standards Adopted in 1917, 36.

registers 355° C., the flame shall be removed from the retort, and any oil which has condensed in the offtake drained into the 355° fraction. The retort is cooled

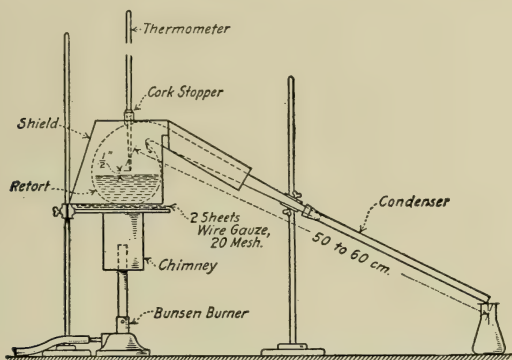

From A. S. T. M. Standards.

FIG. 187.—Retort Method of Distillation.

and reweighed to ascertain the amount of residue, which is generally tested by the float test (Test 8d). The various fractions should be reported by weight and also by volume, and their specific gravities calculated.

CHAPTER XXX

SOLUBILITY TESTS

Test 21. Solubility in Carbon Disulphide. The percentage soluble in carbon disulphide is useful for purposes of identification, for ascertaining the adaptability of a bituminous substance for a given purpose, for gauging its uniformity of supply, and as a criterion of its quality, (i.e., purity, and consequently its intrinsic value). Crude bituminous materials are often purchased on the basis of the percentage soluble in carbon disulphide. The presence of non-mineral matter insoluble in carbon disulphide is an indication that the material has been carelessly prepared and overheated in its process of manufacture. The presence of mineral matter may be regarded as an adulterant. In the case of native asphalts, the larger the percentage soluble in carbon disulphide, the greater their intrinsic value. The percentage and composition of the mineral matter will often indicate the source of the native asphalts. Asphalts derived from petroleum are substantially free from mineral constituents, and with the possible exception of the harder grades, contain little to no non-mineral matter insoluble in carbon disulphide. This test is sometimes employed for determining the value of tars and pitches, although the solubility in hot benzol-toluol is generally used for this purpose (Test 24).

With native asphalt containing over 10 per cent of mineral matter, it is ad isable to separate the portion soluble in carbon disulphide for ascertaining its physical characteristics (Tests 1-12), fusing-point (Test 15), and sometimes fixed carbon (Test 19).

Test 21a. Solubility in Carbon Disulphide. The tests generally employed for this purpose have been devised by the Am. Soc. Testing Materials¹ and are substantially as follows, deviating slightly in phraseology.

The bituminous material should first be freed from moisture. If semi-solid to solid it may be heated in an oven 125° C. for 1 hour, provided it is substantially free from volatile matter at this temperature. If volatile materials are present, it should be dehydrated by distillation at a low temperature, and the water-free distillate returned to the residue, and thoroughly incorporated with it.

¹ "Standard Test for Soluble Bitumen" (Serial Designation D 4-11), *A. S. T. M. Standards Adopted in 1916*, 528; "Tentative Specifications for Asphalt for Use in Damp-proofing and Water-proofing" (Serial Designation: D 40-17 T), *Proc. Am. Soc. Testing Materials*, 17, Part I, 714, 1917.

Sufficient of the dehydrated material to insure the presence of 1-2 g. soluble in carbon disulphide is weighed into a 150-c.c. tared Erlenmeyer flask, and 100 c.c. of c.p. carbon disulphide poured into the flask in small portions, with continuous agitation until all the lumps disappear and nothing adheres to the bottom. The flask is then loosely corked and set aside. From this point on, one of two methods may be followed, depending on whether or not the bituminous material contains a substantial quantity of finely divided insoluble matter.

Procedure Used in the Presence of Substantial Quantities of Finely Divided Insoluble Matter. The flask is set aside to settle for 48 hours, and the solution decanted into a second tared flask, pouring off as much of the solvent as possible without disturbing the residue. The contents of the first flask are again treated with a quantity of carbon disulphide, shaken as before, and both the first and second flasks allowed to settle for another 48 hours. The liquids in both flasks are then carefully decanted upon a weighed Gooch crucible (measuring 4.0 cm. wide at the top, tapering to 3.6 cm. at the bottom, and 2.5 cm. deep), carrying freshly ignited long-fibered amphibole (asbestos) compacted in a layer not over $\frac{1}{8}$ in. No vacuum is to be used in filtering, and the temperature of the liquid kept between 20 and 25° C. The residue remaining on the filter is thoroughly washed with carbon disulphide until the filtrate becomes clear. The flasks are again shaken with fresh carbon disulphide, allowed to settle for 24 hours, or until it is seen that a good subsidence has taken place, and thereupon decanted through the filter. The residues remaining in both flasks are washed until the washings are practically colorless, all washings being passed through the Gooch crucible.

Procedure Followed with Materials Containing Little to no Finely Divided Insoluble Matter. This method is used for rapid work where the bituminous material does not contain insoluble matter which would clog the pores of the filter. After adding the carbon disulphide, the flask is set aside for 15 minutes, whereupon it is filtered through a weighed Gooch crucible. The liquid must be decanted with care, and the decantation stopped at the first sign of sediment coming over. The sides of the flask are washed with a small amount of fresh carbon disulphide, and the sediment caught on the filter, using a "policeman," if necessary, to remove all adhering material. Then wash residue on filter with carbon disulphide until the washings are colorless, and continue the suction until the odor of carbon disulphide is scarcely detectable. The outside of the crucible is cleaned by a cloth moistened with a small amount of the solvent.

In both procedures, the crucible and contents, likewise the two flasks in the first method, are heated for one-half hour at 220° F., cooled in a desiccator and weighed. The difference between the weight of the dehydrated material taken for analysis and the weight of the residue, represents the proportion soluble in carbon disulphide.¹

The author finds that in the presence of large quantities of finely divided insoluble matter, the method may be materially shortened by adding a weighted quantity (about twice the weight of bituminous material) of freshly ignited, long-fibered

¹ For a discussion of the method, see "A Study of Certain Methods for Determining Total Soluble Bitumen in Paving Materials," by S. Avery and R. Corr, *J. Am. Chem. Soc.*, **28**, 648, 1906; "The Proximate Composition and Physical Structure of Trinidad Asphalt, with Special Reference to the Behavior of Mixtures of Bitumen and Fine Mineral Matter," by Clifford Richardson, *Proc. Am. Soc. Testing Materials*, **6**, 509, 1906; "The Determination of Soluble Bitumen," by Hubbard and Reeve, *Proc. Am. Soc. Testing Materials*, **10**, 420, 1910; "The Bitumen Content of Coarse Bituminous Aggregates," by Prévost Hubbard, *Proc. Int. Assoc. Testing Materials*, **XXV-2**, 1912.

amphibole to the bituminous substance in the first flask. On shaking with carbon disulphide, the asbestos serves to dilute the insoluble matter, preventing the latter from clogging the pores of the filter, and accordingly reducing the time of filtration. In many cases this procedure may be adopted to good advantage.

Test 21b. Non-Mineral Matter Insoluble in Carbon Disulphide. The total weight of the insoluble matter obtained in the foregoing test, includes both the non-mineral matter insoluble in carbon disulphide, and the mineral matter. The former is determined by igniting the residue in the Gooch crucible (to which must be added the residues remaining in the flasks) until no carbonaceous particles remain, leaving only the mineral ash. Add a few drops of ammonium carbonate solution to the residue, ignite for a few minutes at a red heat, cool in a desiccator, and weigh. The loss in weight on ignition represents the "non-mineral matter insoluble in carbon disulphide."

Test 21c. Mineral Matter. The residue obtained in the foregoing test represents the mineral constituents. When calcium carbonate is present it is necessary to ignite the residue with ammonium carbonate before finally weighing, as it is claimed that any sulphur present in the bituminous material reacts with the calcium carbonate forming calcium sulphate and calcium sulphide.¹ The loss of any water of hydration from clays, etc., and the oxidation of iron pyrites to ferric oxide, will also affect the results (see p. 534). The mineral matter may be checked by igniting a fresh sample in a platinum crucible to clean ash, adding a few drops of ammonium carbonate, re-igniting and weighing. If the two results do not agree, evaporate the filtrate containing the bituminous matter soluble in carbon disulphide (Test 21a), burn, ignite and weigh the residue. The weight of the ash derived from the bituminous matter soluble in carbon disulphide should be added to the original residue of insoluble mineral matter (Test 21b). This may represent colloidal mineral particles, which are not retained by the filter, or else mineral constituents combined chemically with the bituminous matter (see p. 539).

Test 22. Carbenes. The expression "carbenes" has been applied to that portion of bituminous substances soluble in carbon disulphide but insoluble in carbon tetrachloride. This term was originally proposed by Clifford Richardson.² This test is of value in identifying bituminous substances, gauging their uniformity of supply, for purposes of factory control, and as a criterion of their quality. Certain hard native asphalts and asphaltites, particularly grahamite, normally contain a percentage of carbenes, whereas petroleum asphalts do not show carbenes unless they are overheated, or over-blown. If more than 0.5 per cent is present in petroleum asphalts, their quality is to be regarded as questionable. Carbenes are found in tars and pitches in varying amounts.³

¹ "Analysis of Calcareous Asphaltum and Paving Mixtures," by Prettner, *Chem. Zeit.*, **33**, 917 and 926, 1909.

² "Carbon Tetrachloride and its Use as a Solution for Differentiating Bitumens," by Clifford Richardson and C. N. Forrest, *J. Soc. Chem. Ind.*, **24**, 310, 1905.

³ "Some Relations of the Effect of Overheating to Certain Physical and Chemical Properties of Asphalts," by A. W. Hixson and H. E. Hands, *J. Ind. Eng. Chem.*, **9**, 651, 1917; "The Value of the Carbene Requirement in Asphalt Specifications," by L. Kirschbraun, *Munic. Eng.*, **35**, 349, 1909.

This test is carried out by following the same procedure as in determining the solubility in carbon disulphide (Test 21a), but replacing the latter with carbon tetrachloride. The carbon tetrachloride must be free from carbon disulphide, which may be insured by distilling it under a dephlegmator, discarding any distillate below 76° C. The solvent is then filtered through calcium chloride, and any free hydrochloric acid removed by blowing dry air through it.

The carbon tetrachloride is allowed to act on the bituminous substance overnight, care being taken to keep the vessel in a dark place to protect it from daylight or sunshine.¹ Richardson proposes blowing a gentle current of air through the solution *in the dark* for 1 hour² to coagulate the insoluble matter and assist in the filtration. The difference between the percentages soluble in carbon disulphide and carbon tetrachloride respectively, represents the per cent of "carbenes."

Test 23. Solubility in 88° Petroleum Naphtha. This test is employed mainly for purposes of identification. It is also used to a certain extent for determining the adaptability of a bituminous substance for a given use, for gauging the uniformity of supply, and for purposes of factory control. As a general principle, the harder the bituminous product, the smaller the percentage that will dissolve in 88° naphtha. Asphaltites are relatively insoluble in this menstruum. Mineral waxes, peat-, lignite- and shale tars or pitches are largely soluble. The solubility of native and petroleum asphalts varies, depending largely upon their hardness, and also in the case of petroleum asphalts upon the extent to which the distillation has been driven. Coal-tar pitches are relatively insoluble in 88° naphtha.

The portion soluble in 88° naphtha has been termed "petrolenes" by some, and "malthenes" by others, whereas the non-mineral constituents insoluble in 88° naphtha are generally referred to as "asphaltenes."

It is important that the petroleum naphtha should be derived from petroleum composed entirely of open-chain hydrocarbons, and test exactly 88° Baumé, equivalent to a specific gravity of 0.638 at 60° F./60° F. At least 85 per cent by volume should distil between 95 and 150° F. The density and character of the naphtha is important, since heavy distillates, or products derived from petroleum containing unsaturated or cyclic hydrocarbons will exert a greater solvent action upon the bituminous substance (see p. 467).

This method is performed in the same manner as for determining the portion soluble in carbon disulphide, 88° petroleum naphtha being substituted for the latter. Hard bituminous substances should be powdered; liquid bituminous substances flowed in a thin layer over the bottom of the flask; and semi-solid to semi-liquid substances heated until fluid and distributed in a thin layer to present a greater surface to the solvent. It is advisable not to use a stirring rod, as this causes the bituminous substance to adhere to the inner surface of the flask and to the rod itself. The operation should take place at room temperature, and away

¹ "Studies on the Carbenes," by K. J. Mackenzie, *J. Ind. Eng. Chem.*, **2**, 124, 1910; "On the Formation of Carbenes," by D. B. W. Alexander, *J. Ind. Eng. Chem.*, **2**, 242, 1910.

² "The Modern Asphalt Pavement," 2nd Edition, 546, 1908.

from the direct rays of the sun. The introduction of a weighed portion of long-fibered asbestos to the solution will assist in its filtration.¹

Test 24. Solubility in Other Solvents. Solvents other than those mentioned in the foregoing tests, such as benzol, mixtures of benzol and toluol (Test 31), acetone (see p. 193), etc., are occasionally used for identifying bituminous substances or to investigate their adaptability for a given use. The extraction may be carried out cold or hot, but in either event the method used should be clearly stated in reporting the results. If cold, follow the method described under Test 21*a*, for determining the portion soluble in carbon disulphide. If hot, weigh out approximately 10 g. of the bituminous substance into a paper thimble, and treat with the solvent in a Soxhlet extractor having ground-glass joints. Hard and brittle bituminous substances should be powdered. Medium and soft substances should be mixed with five times their weight of long-fibered amphibole (previously ignited), or ten times their weight of 20- to 30-mesh Ottawa silica to prevent the material fusing together in a solid mass and retard the action of the solvent.

Where the hot extraction is used, the operation is continued for at least 6 hours, and until no further loss in weight is recorded, whereupon the contents of the thimble are dried and weighed.

¹"The Modern Asphalt Pavement," by Clifford Richardson, 2nd Edition, p. 543, 1908; "Laboratory Manual of Bituminous Materials," by Hubbard, 1st Edition, p. 90, 1916.

CHAPTER XXXI

CHEMICAL TESTS

Test 25. Water. The estimation of water is made in some cases for purposes of identification, and in others as a criterion of the quality. Native asphalts and tars are examined in this way to ascertain whether they exist in the crude or the dehydrated state. This test is also used for dehydrating bituminous substances to render them suitable for further examination, where the presence of water would interfere.

Test 25a. Substances Distilling at Low Temperatures. This method is adapted to crude petroleum, tars, creosote oil and other fluid bituminous substances distilling at comparatively low temperatures.¹ The apparatus is set up as shown in Fig. 188. The copper still is provided with a removable flanged top and yoke,

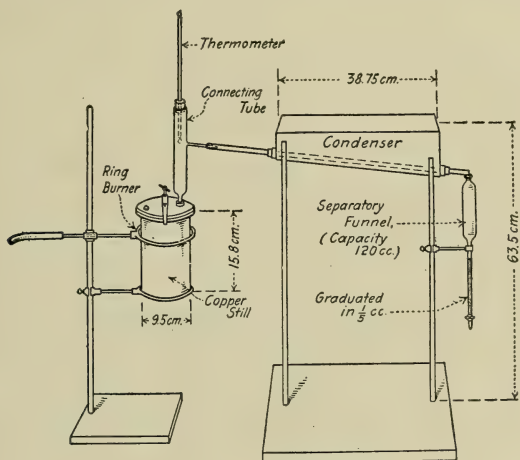

From A. S. T. M. Standards.

FIG. 188.—Still for Determining Water.

which with a paper gasket will form an air-tight joint when clamped into place. The thermometer should be carefully standardized, as provided in the *Am. Soc. Testing Materials Standards*, 1917, p. 37. The condenser consists of a copper trough carrying a straight-walled glass tube. The separatory funnel has a total capacity of 120 c.c. with the outlet graduated in fifths of a cubic centimeter.

¹ "Standard Methods for Sampling and Analysis of Creosote Oil" (Serial Designation: D 38-17), A. S. T. M. Standards, Adopted in 1917, 31.

Pour 200-500 c.c. of the bituminous material into the still and weigh. Clamp the top in place, using a paper gasket moistened with lubricating oil. Apply heat with the ring burner supported just above the level of the bituminous material at the beginning of the test, and then gradually lower it as the water distils over. Continue the distillation until the vapor temperature reaches 205° C. Collect the distillate in the separatory funnel, and let it stand until a clean separation of water takes place. Read off the volume of water, calculate its weight, and figure the per cent present in the crude bituminous material. Draw off the water, and return any light oil to the bituminous matter in the still. The dehydrated material should then be used for further tests.

Test 25b. Substances Distilling at High Temperatures. This method is adapted to asphalts and other bituminous substances comparatively free from volatile constituents, and incapable of distilling without suffering decomposition.

Substances Fusing below 300° F. When it is desired to determine the percentage of moisture without using the residue for other purposes, a convenient method consists in weighing 100 g. into a distilling flask, adding 200 c.c. of kerosene in the case of asphaltic products, or toluol in the case of tar products, and warming gently under a reflux condenser until the bituminous substance mixes with the solvent. Cool, add a quantity of dry pumice-stone to prevent bumping, and distil into a graduate until the liquid comes over clear. The distillate is then allowed to settle by gravity, and the volume of water read off directly; or else the water may be withdrawn with a pipette, and weighed. This method is said to be accurate to approximately 0.033 g. of water per 100 c.c. of toluol or kerosene present in the distillate.¹

Where the hydrated material is to be used for further examination, 25 g. are weighed into an Erlenmeyer flask, through which a current of dry illuminating gas is passed, and maintained at 105° C. for 1 hour. The vapors are led through a return condenser maintained at 50° C., and then into a weighed calcium chloride tube. When all the moisture is driven off, the calcium chloride tube is reweighed and the moisture calculated. If constituents are present volatilizing below 50° C., the return condenser should be maintained at a corresponding lower temperature.

Substances Fusing above 300° F. In this case the material is comminuted by powdering (to about 60 mesh) or shaving, and a weighed quantity spread in a thin layer on glass and maintained in an oven at 125° C. for 1 hour, or until the weight becomes constant. If the substance is oxidizable in air, it should be heated in an atmosphere of illuminating gas. Cool in a desiccator, reweigh and calculate the per cent moisture.

Tests 26. Carbon, and 27. Hydrogen. Carbon and hydrogen are grouped together, because both are generally determined simultaneously. These are of value in establishing the identity of bituminous materials, in connection with the corresponding percentages of sulphur, nitrogen and oxygen.

The electrical combustion method is now used almost exclusively for determining carbon and hydrogen. A weighed quantity of the material is caused to undergo combustion and the gaseous products are thoroughly oxidized by being passed over

¹"Methods for the Determination of Water in Petroleum and its Products," by I. C. Allen and W. A. Jacobs, Tech. Paper 25, Dept. of Interior, Bureau of Mines, Wash., D. C., 1912.

red-hot copper oxide and lead chromate. The water generated is absorbed in a weighed Marchand calcium-chloride tube, and the carbon dioxide in a weighed Liebig bulb containing a 30 per cent solution of potassium hydroxide. A furnace of the Heraeus type (Fig. 189) consisting of electrical heaters *a*, *b*, and *c*; two of which, namely, *a* and *b* are mounted on sheave wheels running on a track so they may be moved along the combustion tube; the third heater *c* being stationary and constructed by winding an alundum or fused quartz tube 12 cm. long with No. 16 nichrome II wire, and enclosed in a cylinder packed with magnesia-asbestos. Heater *c* surrounds the lead chromate in the combustion tube. The movable heaters *a* and *b* have thin platinum foil (weighing about 9 g. in all) wound on a porcelain or fused quartz combustion tube of 30 mm. internal diameter. The large heater *b*, 350 mm. long, surrounds the copper oxide, and the smaller one *a*, 200 mm. long, heats the sample in the boat. The combustion tube *d* of Jena glass or fused silica, measuring 21 mm. external diameter and 900 mm. long, is supported by an asbestos-lined nickel trough *e*. The current through each heater is regulated by separate rheostats *f* and *g*, the heating coils *a* and *b* requiring about 4.5 amperes at 220 volts.

The furnace is arranged so either air or oxygen may be passed through the combustion tube, and is equipped with two purifying trains in duplicate (of which but one is shown in the figure) connected to the combustion tube by a Y-tube, the joint being made tight by a rubber stopper. The purifying apparatus *H* contains the following reagents in order of the passage of the air or oxygen through them: sulphuric acid *i*, for removing any traces of ammonia; a 30 per cent potassium hydroxide solution *j*; granular soda-lime *k*; and granular calcium chloride *l*. One of the purifying trains is connected directly with an oxygen tank provided with a reducing valve for regulating the pressure, and the other being used for purifying the air supply, which is drawn through the apparatus by an aspirator connected with the other end of the combustion tube.

The first 30 cm. of the combustion tube are empty; then comes an asbestos plug (acid-washed and ignited); the next 40 cm. are filled with copper oxide gauze; then a second asbestos plug; then 10 cm. of fused lead chromate; and finally another asbestos plug 20 cm. from the end of the tube.

The absorption train consists of a 4-in. U-tube *m* filled with granular calcium chloride (previously saturated with carbon dioxide) to absorb the moisture. This in turn is connected to a Vanier potash bulb *n* containing a 30 per cent potassium hydroxide solution and granular calcium chloride. The potash bulb is connected with an aspirator through the guard-tube *o* containing granular calcium chloride and soda-lime. A Mariotte flask *p*, serves to keep the suction constant.

It is important to see that all connections are made tight. Before starting a

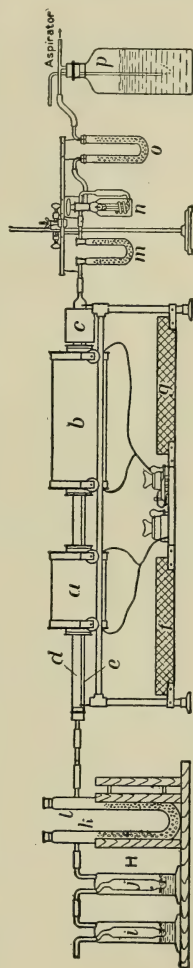

Fig. 189.—Combustion Furnace for Ultimate Analysis.

determination or after any changes in chemicals or connections, a blank test should be run by aspirating 1 liter of air through the apparatus, which is heated in the same manner as though a determination were being made. If the Vanier bulb *n* or the calcium chloride tube *m* show a change in weight of less than 0.5 mg. each, the apparatus may be considered in a satisfactory condition.

Approximately 0.25 g. of the bituminous substance is carefully weighed into a porcelain or platinum boat and transferred to the combustion tube which should be cool for the first 30 cm., the copper oxide at a bright-red heat, and the lead chromate at a dull-red heat. The boat should be introduced rapidly near the asbestos plug at the beginning of the copper oxide, the stopper connecting with the purifying train replaced and pure oxygen passed through at the rate of 3 bubbles per second. The current is *gradually* turned on heating coil *a*, which at the start should be at the right of the boat. By manipulating the rheostat, and gradually pushing the coil towards the boat, the evolution of volatile matter is carefully controlled to prevent too rapid an evolution of gas and tar, which may either escape complete combustion or be driven back into the purifying train. The heat should accordingly be increased slowly by manipulating the rheostat, until the sample ignites, whereupon the temperature may be increased rapidly. Any moisture collecting in the end of the combustion tube or in the rubber connection joining it to the calcium-chloride tube *m* is driven into the latter by carefully warming with a hot tile. After the sample ceases to glow, the oxygen is continued for 2 minutes, whereupon the heat is turned off, and 1200 c.c. air aspirated through the train. The absorption bulbs are disconnected, wiped clean, allowed to cool and weighed. The percentage of carbon is equal to the increase in weight of the KOH bulb (*n*) multiplied by 27.27 and divided by the weight of the sample. The percentage of hydrogen is equal to the increase in weight of the CaCl_2 tube (*m*) multiplied by 11.19 and divided by the weight of the sample.¹

Test 28. Sulphur. This test is also used for differentiating and identifying bituminous substances.

A number of methods have been proposed for this purpose, but the most rapid and accurate one consists in igniting about 1 g. of the material in an approved form of bomb calorimeter, preferably of the Berthelot type (500–600 c.c. capacity), containing 10 c.c. of water and filled with oxygen under a pressure of 30 atmospheres. The bituminous substance is weighed on a small lump of chemically pure cotton (free from sulphur) and placed on a small platinum cone, which in turn is suspended from a copper wire. The cotton is connected with a thin platinum wire forming a short-circuit between the suspended copper wire and the return conductor.

After the combustion has taken place, the bomb is allowed to cool for 15 minutes, then opened up and its contents washed into a beaker. If the bomb has a lead washer, 5 c.c. of a saturated solution of sodium carbonate should be added, and the contents boiled for 10 minutes to decompose any lead sulphate emanating from the washer. The solution is then filtered, washed, acidified with 5 c.c. of dilute hydrochloric acid (1 : 2), boiled to expel any carbon dioxide, and precipitated with 20 c.c. of a hot 5 per cent solution of barium chloride. The solution is allowed

¹ "Methods of Analyzing Coal and Coke," by F. M. Stanton and A. C. Fieldner, Tech. Paper 8, Dept. of Interior, Bureau of Mines, Wash., D. C., 1913. "Standard Methods for Laboratory Sampling and Analysis of Coal" (Serial Designation: D 22-16), A. S. T. M. Standards, Adopted 1916, 565.

to stand for at least 2 hours at a temperature just below its boiling-point, and the following day is filtered through an ashless paper and washed with pure hot water until a drop of the filtrate shows no precipitate with silver nitrate solution. The test for excess of barium chloride is made by adding a few drops of sulphuric acid to the filtrate. The precipitate is then ignited in a weighed fused silica crucible, cooled and weighed. The weight of the barium sulphate multiplied by 13.74, divided by the weight of the sample is equal to the percentage of sulphur present.¹ The Eschka method for determining sulphur is not recommended for bituminous materials.

A rapid test for detecting the presence of sulphur qualitatively,² consists in dissolving 10 g. of the substance in 25 c.c. benzol with gentle heating, cooling and adding 30 c.c. N/2 alcoholic potash, shaking, and then rapidly diluting with 200 c.c. 96 per cent alcohol. After standing a short time, the liquid (which should test alkaline to phenolphthalein) is decanted. The residue is washed with alcohol, dried on a water bath and finally at 105° C. It is then heated with 100 cc. of ether under a reflux condenser, and a few lumps of granular calcium chloride are added. After cooling, the liquid is filtered into a test tube to remove any insoluble matter present, and the solution mixed with 20 c.c. 2 per cent mercuric bromide in ether, and allowed to stand overnight. If a precipitate forms, it is filtered off, washed with ether, and dissolved from the filter paper with warm benzol. If any sulphur-bearing bituminous substances are present, including petroleum or native asphalts, the precipitate will dissolve in the benzol forming a dark brown solution (any mercuric bromide present remaining undissolved). On evaporating the benzol, the mercuric-bromide-sulphur-compound is deposited as a dark brown to black brittle mass.

Test 29. Nitrogen. This determination is also used for identifying bituminous products, and the procedure ordinarily employed constitutes the well-known Kjeldahl-Gunning method.³

One gram of the bituminous material, which should be finely powdered when sufficiently hard, is boiled with 30 c.c. of concentrated sulphuric acid, 7-10 g. of potassium sulphate, and 0.6-0.8 g. of metallic mercury in a 500-c.c. Kjeldahl flask until the material is completely oxidized and the solution becomes clear. The boiling should be continued at least two hours after the solution reaches the straw-colored stage, the total time required ranging from 3 to 4 hours. After the solution has cooled, a few crystals of potassium permanganate are added to insure complete oxidation. When thoroughly cool, the solution is diluted to 200 c.c. with cold water, again cooled, and the following solutions added: 25 c.c. of a 4 per cent

¹"The Sulphur Content of Fuels, and Especially Petroleum Products," by I. C. Allen and I. W. Robertson, Tech. Paper 26, Bureau of Mines, Dept. of Interior, Wash., D. C., 1912; "Sulphur in Tar Residues," by Prévost Hubbard and C. S. Reeve, *Proc. Am. Soc. Testing Materials*, **11**, 666, 1911; "The Detection and Determination of Sulphur in Petroleum," by C. K. Francis and C. W. Crawford, *J. Ind. Eng. Chem.*, **9**, 479, 1917.

²"J. Marcusson, "The Composition and Examination of Residues from Fat Distillation," loc. cit.

³"Methods of Analyzing Coal and Coke," by F. M. Stanton and A. C. Fieldner, Tech. Paper 8, Bureau of Mines, Dept. of Interior, Wash., D. C., 1913; "Determination of Nitrogen in Coal," by A. C. Fieldner and C. A. Taylor, Tech. Paper 64, Bureau of Mines, Dept. of Interior, Wash., D. C., 1915. "Standard Methods for Laboratory Sampling and Analysis of Coal" (Serial Designation: D 22-16); *A. S. T. M. Standards, Adopted 1916*, 570.

solution of potassium sulphide to precipitate the mercury; 1-2 g. of granular zinc to prevent bumping; and finally enough saturated sodium hydroxide (usually 80-100 c.c.) to make the solution distinctly alkaline. The danger of losing ammonia may be minimized by holding the flask in an inclined position while the sodium hydroxide solution is being added and carefully running the alkaline solution down the side of the flask so it will form a layer below the acid solution. The flask should then be at once connected with the condensing apparatus, and the solution mixed by gently rotating the flask.

The ammonia is then distilled into 10 c.c. of standard sulphuric acid solution at the rate of 100 c.c. per hour, until 150-200 c.c. of distillate have passed over. The distillate is then titrated with standard ammonia or caustic soda solution, using cochineal as indicator with the former, or methyl orange with the latter (20 c.c. standard ammonia or caustic soda solution are equal to 10 c.c. of standard sulphuric acid, and also equivalent to 0.05 g. nitrogen).

Test 30. Oxygen. There being no satisfactory direct method for determining oxygen, it is computed by subtracting the sum of the percentages of hydrogen, carbon, nitrogen, sulphur, water and ash from 100 per cent. The result so obtained is affected by all the errors incurred in the other determinations, and especially by the change in weight of the ash-forming constituents on ignition. Iron pyrites will absorb oxygen from the air and change to ferric oxide, increasing the weight of ash, and thereby causing a negative error in the oxygen, equivalent to three-eighths of the pyritic sulphur. Any calcium carbonate present will tend to absorb sulphur combined with the bituminous constituents (p. 526). On the other hand, there is always a loss on ignition of "water of composition" from the clayey and shaley constituents, also carbon dioxide from carbonates, etc., which tend to compensate for the absorption of oxygen.¹

Test 31. Free Carbon in Tars. This represents an adaptation of Test 24 suitable for testing tars and pitches for the presence of non-mineral matter insoluble in hot toluol-benzol, which has been found the most satisfactory menstruum for this purpose.² This test is of value for purposes of identification, for ascertaining the adaptability of the tar or pitch for a given purpose, and for gauging the uniformity of supply. Tars and pitches containing large percentages of free carbon are objectionable for certain purposes of manufacture, since the free carbon acts as so much inert matter, and furthermore is insoluble in all solvents.

¹ "Standard Methods for Laboratory Sampling and Analysis of Coal" (Serial Designation: D 22-16), *A. S. T. M. Standards, Adopted 1916*, 571.

² "Free Carbon in Tars," by J. M. Weiss, *J. Ind. Eng. Chem.*, **6**, 279, 1914; "Some Effects of Certain Solvents on Tars in the 'Free Carbon' Determination," by G. S. Monroe and H. J. Broderson, *J. Ind. Eng. Chem.*, **9**, 1100, 1917.

The apparatus used was devised by H. J. Cary-Curr¹ and is illustrated in Fig. 190. The filtering medium may consist either of a paper thimble or two thicknesses of Schleicher & Schuell's No. 575 hardened filter paper, 15 cm. in diameter, arranged in the shape of a cup by folding symmetrically around a stick 1 in. in diameter. It should be soaked in benzol to remove any grease, dried in an oven, desiccated and weighed.

Tars must be dehydrated before extracting, and pitches if sufficiently hard, ground to a fine powder. In testing materials containing more than 5 per cent of free carbon, 5 g. should be used, and 10 g. with smaller percentages. Weigh a suitable amount in a 100-c.c. beaker and digest with 50 c.c. c.p. toluol on a steam bath with constant stirring for not exceeding 30 minutes. Place the prepared filter paper in a carbon filter-tube and decant the toluol extract through it. Wash with hot c.p. toluol until the filtrate is clear, using a policeman unaffected by toluol for detaching any free carbon adhering to the beaker. Finally wash the filter with hot c.p. benzol, and after draining, cover it with a cap of filter paper or alundum ware, and extract it in the apparatus with c.p. benzol until the drippings become colorless. This will take at least 2 hours. The filter is then removed, the cap taken off, the paper dried in a steam oven, cooled in a desiccator and weighed. With pitches it is well to examine the free carbon for foreign matter, such as wood slivers, pieces of bagging, etc. If such foreign matter is present, the test should be rejected.²

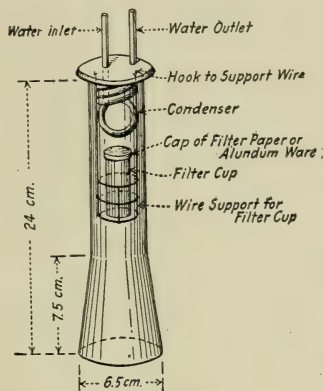

From A. S. T. M. Standards.

FIG. 190.—Cary-Curr Extraction Apparatus.

Test 32. Naphthalene in Tars. Naphthalene is present in tars and pitches generated at high temperatures, including those derived from coal. It is produced by the condensation of two or more hydrocarbon molecules accompanied by the elimination of hydrogen. (See p. 227.) The following test is used solely for purposes of identification:

One hundred c.c. of tar, or 100 g. of pitch are weighed into a tared Engler flask, and distilled by the flask method (Test 20a, p. 521). With tars the distillation is continued until 95 per cent has been distilled off, and in the case of pitches it is stopped when the temperature reaches 355° C. The time of distillation should occupy about 20 minutes, and the condenser tube heated to prevent the distillate from solidifying in it. The distillate is caught in a separatory funnel, the lower portion of which is graduated. This is immersed in water at 60° C. and a reading taken, whereupon 50 c.c. of a 10 per cent caustic soda solution are added, shaken, allowed to settle, and the clear soda drawn off. The contents are warmed again to 60° C., and the loss in volume noted. Shake with another 30 c.c.

¹ *J. Ind. Eng. Chem.*, **4**, 535, 1912.

² "Tentative Specifications for Coal-tar Pitch for Use in Damp-proofing and Waterproofing," (Serial Designation: D 42-17 T), *Proc. Am. Soc. Testing Materials*, **17**, Part I, 719, 1917.

of soda, and observe whether there is any further diminution in volume. If so, repeat until no further shrinkage occurs. The total shrinkage represents the *tar acids* present in the distillate.

The oil which is unacted upon is placed in a copper beaker maintained at 60° F. for 15 minutes, and the separated naphthalene filtered on a paper in a perforated funnel, using suction. The naphthalene is pressed between several sheets of filter paper in a letter press to remove the adhering oil, weighed, and its percentage calculated.

Test 33. Solid Paraffines. Until recently, it was considered that the presence of paraffine was an indication of the quality of asphaltic products, and many specifications stipulated the maximum percentage permissible. It is now generally conceded, however, that there is no rational bearing between the solid paraffines in asphaltic products and their quality. The determination of paraffine is therefore of value only for purposes of identification. Solid paraffines are never found in asphaltites, rarely in natural asphalts, and only traces in asphalts produced from strictly asphalt-base petroleums. On the other hand, more or less paraffine is present in asphalts derived from non-asphaltic and mixed-base petroleums. It is absent in tars and pitches derived from high temperature distillation processes (see table p. 483).

The following method does not give absolute figures, since it merely discloses the paraffine hydrocarbons which are *solid* at room temperature, without taking the liquid paraffines into consideration; nevertheless the results are of value for purposes of comparison.¹ Weigh 50 g. of the material in a tared 6-oz. glass retort, and slowly distil until nothing but a residue of coke remains. The distillation should take in the neighborhood of 45 minutes from the time the first drop comes over. The distillate is caught in an Erlenmeyer flask, and weighed. Either 5 or 10 g. of the well mixed distillate, depending upon the quantity of solid paraffines present in the crude material, are transferred into a large test tube and dissolved in 25 c.c. of absolute ethyl ether and 25 c.c. of absolute ethyl alcohol. A similar mixture containing 25 c.c. each of ether and alcohol is made up, and this together with the oil solution is cooled separately to exactly 0° F. for $\frac{1}{2}$ hour in a mixture of ice and salt (to which if necessary calcium chloride may be added). The oil solution is then rapidly filtered through a weighed Gooch crucible, similarly maintained at 0° F. by a jacket of ice and salt, and washed with 50 c.c. of the cooled ether-alcohol mixture. A simple and convenient apparatus consists of an inverted bottle 6 in. in diameter, having the bottom cut off, and attached to the same rubber stopper which supports the funnel holding the Gooch crucible. The space between the bottle, the crucible, and the supporting funnel is packed with the ice and salt mixture. The Gooch crucible is then removed, the outside wiped clean, placed on a tared glass and dried in an oven at 80° C. until the last traces of ether and alcohol

¹ "The Modern Asphalt Pavement," by Clifford Richardson, 2nd Edition, 558, 1908; "Untersuchung der Kohlenwasserstofföle und Fette," by D. Holde, Berlin, 45, 1913; "Laboratory Manual of Bituminous Materials," by Prévost Hubbard, N. Y., 100, 1916.

are evaporated. The residue is weighed, and the percentage of solid paraffines calculated in the original 50 g. of substance taken for analysis.¹

According to Holde (*loc. cit.*), the *refractive index* of the solid paraffines will indicate whether the original substance was ozokerite or paraffine, or a mixture of the two. An alcoholic extract is tested at 90° C. on the Zeiss butyro-refractometer. The residue from ozokerite will show a refractive index of 11.5–17.0, whereas the solid paraffines derived from petroleum, shale, lignite, etc., will test between 1.6 and 6.8.

Test 34. Saturated Hydrocarbons. This method was devised by Richardson,² and serves to distinguish between various asphaltic products, including native asphalts, asphaltites and petroleum asphalts. It is used for purposes of identification.

The portion soluble in 88° petroleum naphtha, separated as in Test 23, is brought to exactly 100 c.c. either by adding more 88° naphtha or else by evaporation. This is then shaken in a 500-c.c. separatory funnel at 77° F. for *exactly* 3 minutes, with 30 c.c. of a mixture of concentrated sulphuric acid and fuming sulphuric acid, having a specific gravity of 1.84 at 77° F. The funnel is allowed to stand quietly overnight, whereupon the acid is drawn off and the oils unacted upon treated with another 30 c.c. of the acid. This time a few hours' standing should effect a sharp separation. If the second acid layer is strongly colored, the treatment should be repeated a third time. The naphtha solution is washed successively with water, a 5 per cent solution of sodium carbonate and finally with water. The solution is evaporated to dryness over a steam bath and the residue weighed. This is equal to the saturated hydrocarbons present in the portion soluble in 88° petroleum naphtha. As a guide in evaporating the last traces of naphtha from the saturated hydrocarbons, a blank test should be run on 100 c.c. of the 88° naphtha, whereupon the portion unacted upon is mixed with 0.75 g. of a non-asphaltic petroleum residuum and evaporated on the steam bath alongside of the sample under test, until the former is reduced to exactly its original weight.

The results are expressed as the percentage of saturated hydrocarbons present in the portion soluble in carbon disulphide (Test 21*a*). This is calculated in the following manner: If *a* represents the percentage soluble in carbon disulphide, *b* the percentage soluble in 88° naphtha and *c* the percentage of saturated hydrocarbons in *b*; then the saturated hydrocarbons present in the portion soluble in carbon disulphide will equal $\frac{bc}{a} \times 100$.

Test 35. Sulphonation Residue. This test expresses the percentage of saturated hydrocarbons in the distillate between 315 and 355° C. obtained upon subjecting the bituminous substance to the flask method of

¹An alternate method used with success by the author, consists in dissolving 10 g. of the substance in the smallest amount of benzol, applying heat if necessary, adding 200 c.c. of 88° naphtha, filtering through dried fuller's earth and washing with additional 88° naphtha until the filtrate is clear. This removes the dark colored asphaltic substances. The filtrate containing the paraffine is distilled to a small bulk, evaporated to dryness on the water bath, the residue dissolved in 25 c.c. of ether and 25 c.c. of alcohol, and treated as described above.

²"The Modern Asphalt Pavement," 2nd Edition, N. Y., 544, 1908.

distillation (Test 20a). It is used to differentiate tars and pitches among themselves as well as from mineral waxes, asphalts (native and pyrogenous) and asphaltites. The figures for coal-tar pitches have already been given on p. 252. The author cites the following additional figures: wood-tar pitch 0 per cent, saponifiable fatty-acid pitches 0 per cent, unsaponifiable fatty-acid pitches 0 per cent, residual asphalt from Mexican asphaltic petroleum 86 per cent, wurtzilite asphalt 87 per cent and gilsonite 85 per cent.

The method of determining the sulphonation residue as proposed by Dean & Bateman,¹ consists in distilling sufficient of the material under examination by the flask method (Test 20a) to obtain at least 10 c.c. of distillate between 315 and 355° C. Exactly 10 c.c. of this fraction are measured into a Babcock milk bottle, and 40 c.c. of 37 normal sulphuric acid added, 10 c.c. at a time. The bottle and its contents are shaken for 2 minutes after each addition, and when all the acid has been added, the bottle is kept at a constant temperature of 98–100° C. for one hour, during which it is shaken vigorously every 10 minutes. At the end of the hour, the bottle is removed, cooled, filled to the top of the graduations with ordinary sulphuric acid, and whirled for 5 minutes in a Babcock separator. The unsulphonated residue multiplied by 2 gives the per cent by volume directly (each graduation being equal to $\frac{1}{200}$ of a c.c.).

It is important that the acid should be of the proper strength. A mixture of fuming sulphuric acid and ordinary concentrated sulphuric acid should be prepared to contain exactly 80.07 per cent of SO₃, which constitutes 37 normal acid. If the sulphonation residue is dark in color, it should be treated with an excess of a 10 per cent sodium hydroxide solution, and if soluble in this reagent, the test is regarded as negative.

The "dimethyl sulphate test"² was originally proposed for this purpose, but has been since disregarded on account of its unreliability.

Test 36. Mineral Matter. Under this heading we will consider in detail the examination of the mineral matter, including the portion present in the uncombined state; the portion combined with non-mineral constituents; a qualitative or quantitative chemical analysis; also microscopic and granulometric analyses. The distribution of the mineral matter, its chemical analysis and microscopic examination are of value for purposes of identification. Its granulometric and in some cases its chemical analysis serve as an indication of its adaptability

¹ "The Analysis and Grading of Creosotes," Forest Service Circular 112, Wash., D. C.; "Modification of the Sulphonation Test for Creosote," Forest Service Circular 191, Wash., D. C.; "Methods for Testing Coal Tar and Refined Tars, Oils and Pitches Derived Therefrom," by S. R. Church, *J. Ind. Eng. Chem.*, **3**, 233, 1911; **5**, 196, 1913; "Paraffin Bodies in Coal Tar Creosote and their Bearing on Specifications," by S. R. Church and J. M. Weiss, *J. Ind. Eng. Chem.*, **6**, 396, 1914.

² "Methods of Asphalt Examination," by Albert Sommer, *J. Ind. Eng. Chem.*, **2**, 181, 1910; "Application of the Dimethyl Sulphate Test for Determining Small Amounts of Petroleum or Asphalt Products in Tars," by C. S. Reeve and R. H. Lewis, Congress of Applied Chemistry, **25**, 727, 1912; *J. Ind. Chem.*, **5**, 293, 1913.

for a given purpose, particularly where it is desired to determine the resistance to acids or alkalis, etc. The percentage and distribution of the mineral matter and its granulometric analysis are used for gauging the uniformity of supply. The percentage of mineral matter present, and its granulometric analysis serve as a criterion of the quality for paving purposes.

Test 36a. Uncombined Mineral Matter. This includes the non-mineral matter insoluble in carbon disulphide, and corresponds to the results obtained by Test 21b (p. 526). Any uncombined mineral matter, or colloidal particles fine enough to pass through an asbestos filter would not be included in this determination.

Test 37b. Mineral Matter Combined with Non-Mineral Constituents. This is ascertained by evaporating the carbon disulphide extract of the bituminous aggregate (Test 21a), burning the residue and ascertaining the weight of the ash thus obtained. It will include: (1) the mineral constituents chemically combined with the bituminous matter; (2) colloidal mineral constituents which pass through an asbestos filter.

The appearance of the ash on ignition will indicate which of these two classes is present. If the ash appears as a gossamer-like froth, it will indicate that the mineral matter is chemically combined with the bituminous constituents. If the ash forms a fine powder, it is an indication that it exists in the form of colloidal particles.

Test 36c. Chemical Analysis of Mineral Matter. This may include a qualitative or a quantitative analysis, by any of the methods ordinarily used for this purpose. If a quantitative analysis is to be made, the reader is referred to the following sources, viz.:

Mineral Constituents Naturally Present and Added Fillers: "Tentative Methods for Ultimate Chemical Analysis of Refractory Materials," Serial Designation: C 18-17 T), *Proc. Am. Soc. Testing Materials*, 17, Part I, 671, 1917; "Standard Specifications and Tests for Portland Cement" (Serial Designation: C 9-17), *A. S. T. M. Standards, Adopted 1916*, 432.

Added White Pigments. "Standard Methods for Routine Analysis of White Pigments," *A. S. T. M. Standards, Adopted in 1917*, 18.

Added Yellow, Red or Brown Pigments. "Tentative Methods for Routine Analysis of Yellow, Orange, Red and Brown Pigments Containing Iron and Manganese," (Serial Designation: D 50-17 T), *Proc. Am. Soc. Testing Materials*, 17, Part I, 802, 1917.

Test 36d. Microscopic Examination. This is performed by examining a small quantity of the mineral matter on a microscope slide under a magnification of 100 diameters. The method is adapted only to finely divided mineral matter, and in many cases serves to identify the various forms, such as infusorial earth, clay, silica, etc. This test will also give an idea as to the relative fineness of the particles.

Test 36e. Granulometric Analysis. The methods which follow have been standardized by the American Society for Testing Materials¹ for mineral aggregates

¹Standard Method for Making a Mechanical Analysis of Sand or Other Fine Highway Material, Except for Fine Aggregates Used in Cement Concrete" (Serial Designation: D 7-16); "Standard Method for Making a Mechanical Analysis of Broken Stone or Broken Slag, Except for Aggregates Used in Cement Concrete" (Serial Designation: D 18-16); "Standard Method for Making a Mechanical Analysis of Mixtures of Sand or Other Fine Material with Broken Stone or Broken Slag, Except for Aggregates Used in Cement Concrete" (Serial Designation: D 19-16), *A. S. T. M. Standards, Adopted in 1916*, 535, 537 and 538.

used in connection with highways. The following three methods have been adopted:

For Sand or Other Fine Highway Material. The method consists of: (1) drying at not over 230° F. to a constant weight a sample weighing 50 g.; (2) passing the sample through each of the following mesh sieves.

Meshes Per Linear Inch (2.54 cm.).	Diameter of Wire.	
	In.	Mm.
200	0.00235	0.05969
100	0.0045	0.1143
80	0.00575	0.1460
50	0.009	0.22865
40	0.01025	0.26035
30	0.01375	0.34925
20	0.0165	0.4191
10	0.027	0.6858

The order in which the sieves are to be used in the process of sifting is immaterial and shall be left optional; but in reporting results, the order in which the sieves have been used shall be stated; (3) determining the percentage by weight retained on each sieve, the sifting being continued until less than 1 per cent of the weight retained shall pass through the sieve during the last minute of sifting; and (4) recording the mechanical analysis in the following manner:

Passing 200-mesh sieve.....	%
Passing 100-mesh sieve and retained on a 200-mesh sieve.....	%
Passing 80-mesh sieve and retained on a 100-mesh sieve.....	%
Passing 50-mesh sieve and retained on a 80-mesh sieve.....	%
.....	%
Total.....	100.00%

For Broken Stone or Broken Slag. The method shall consist of: (1) drying at not over 230° F. to a constant weight a sample weighing in pounds 6 times the diameter in inches of the largest holes required; (2) passing the sample through such of the following size screens having circular openings as are required or called for by the specifications, screens to be used in the order named: 3½, 3, 2½, 2, 1½, 1¼, 1, ¾, ½ and ¼ in.; (3) determining the percentage by weight retained on each screen; and (4) recording the mechanical analysis in the following manner:

Passing ¼-in. screen.....	%
Passing ½-in. screen and retained on a ¼-in. screen.....	%
Passing ¾-in. screen and retained on a ½-in. screen.....	%
Passing 1-in. screen and retained on a ¾-in. screen.....	%
.....	%
Total.....	100.00%

For Sand or Other Fine Material with Broken Stone or Broken Slag. The method shall consist of: (1) drying at not over 230° F. to a constant weight, a sample weighing in pounds 6 times the diameter in inches of the largest holes required; (2) separating the sample by the use of a screen having circular openings ¼ in. in diameter; (3) examining the portion retained on the screen in accordance with the method for broken stone or broken slag; (4) examining the portion passing the screen in accordance with the method for sand or other fine highway material; and (5) recording the mechanical analysis in the following manner:

Passing 200-mesh sieve.....	%
Passing 100-mesh sieve and retained on a 200-mesh sieve.....	%
Passing 80-mesh sieve and retained on a 100-mesh sieve.....	%
.....	%
Passing 10-mesh sieve and retained on a 20-mesh sieve.....	%
Passing ¼-in. screen and retained on a 10-mesh sieve.....	%
Passing ½-in. screen and retained on a ¼-in. screen.....	%
Passing ¾-in. screen and retained on a ½-in. screen.....	%
.....	%
Total.....	100.00%

Elutriation Test for Sand or Fine Filler. This test is adapted to fine mineral particles passing a 200-mesh sieve. Place 5 g. in a beaker about 120 mm. high, holding 600 c.c., and fill almost to the top with distilled water at exactly 70° F. Agitate with compressed air until the mineral particles are brought into suspension, and in such a manner that no whirling results. Stop the blast and allow the liquid to stand exactly 20 seconds, whereupon the water above the sediment is immediately decanted through a 200-mesh sieve without, however, pouring off any of the sediment. The operations of agitation, sedimentation, and decantation are repeated with fresh water three times. The particles caught on the 200-mesh sieve are washed back into the sample remaining in the beaker, which is dried to constant weight and weighed. The difference represents the amount removed by elutriation, which should be expressed in percentage.¹

Test 36f. Specific Gravity of Mineral Matter. Two methods are recommended, depending upon whether the particles are finer or coarser than 1 in. in diameter.

For Aggregates Whose Particles are Less than ¼ In. The U. S. Bureau of Standards' Modification of Le Chatelier's flask is

¹ "Standard Forms for Specifications, Tests, Reports and Methods of Sampling for Road Materials," Bulletin No. 555, U. S. Dept. Agriculture, Wash., D. C., p. 32, Nov. 26, 1917.

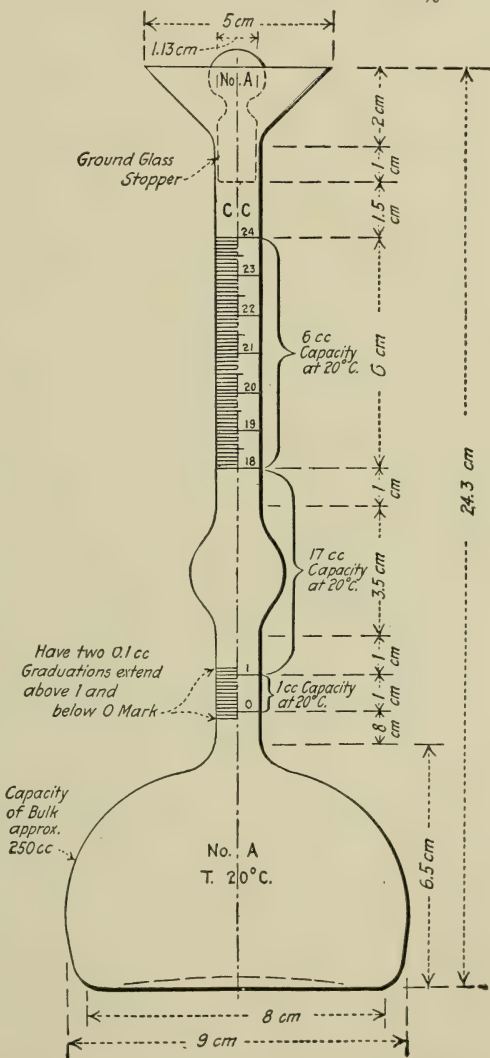

From A. S. T. M. Standards.
 FIG. 191.—Bureau of Standards' Modification of Le Chatelier's Specific Gravity Flask.

used¹ as illustrated in Fig. 191. It is first filled with kerosene to a point on the stem between 0 and 1 c.c., and 57 g. of the aggregate at the same temperature as the liquid slowly introduced, and freed from air by rolling the flask in an inclined position. After all the aggregate has been introduced, the level of the liquid will rise to some division on the graduated neck, the difference between the readings being equal to the volume displaced. The flask during the operation shall be immersed in water at a definite temperature. The specific gravity at this temperature is equal to the weight of the aggregate in grams divided by the volume displaced in cubic centimeters.

For Aggregates Composed of Fragments Larger than $\frac{1}{4}$ In. The Goldbeck apparatus² illustrated in Fig. 192 is used for this purpose; 1000 g. of aggregate are dried to constant weight, weighed to the nearest 0.5 g., and immersed in water for 24 hours. The pieces are then individually surface-dried with a towel, the sample reweighed and immediately introduced into the cylinder, which has previously been filled to overflowing with water at 77° F. The displaced water is caught in a tared beaker, and weighed. If the weight of the dry aggregate in air is *a*, and the weight of the displaced water *b*, then the apparent specific gravity is equal to *a* divided by *b*. The difference between the original weight of the specimen and its weight after 24 hours' immersion is used to determine the percentage of absorption. If *c* equals the weight of the water absorbed by the dry specimen in 24 hours, then the true specific gravity at 77° F. is equal to *a* divided by (*b* - *c*).

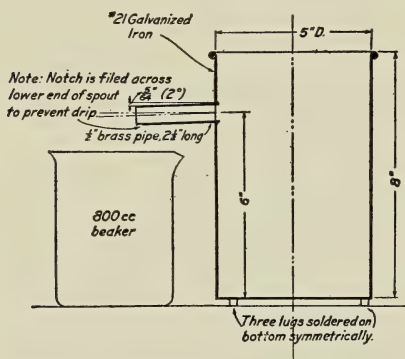

FIG. 192.—Goldbeck's Specific Gravity Apparatus.

absorption. If *c* equals the weight of the water absorbed by the dry specimen in 24 hours, then the true specific gravity at 77° F. is equal to *a* divided by (*b* - *c*).

Test 37. Saponifiable Constituents. Under this heading will be included tests applicable to oils, fats and resins, including the acid value, lactone value, ester value, and saponification value, also the separation of fatty and resin acids. These tests are adapted to certain bituminous substances for purposes of identification, also for gauging the uniformity of supply. They are especially suitable for examining: montan wax, wood tar and wood-tar pitch, rosin pitch and fatty-acid pitch, and to determine the quality of the last named.

The relation between the acid, lactone, ester and saponification values, also the unsaponifiable and saponifiable constituents is shown in the following table:

¹ Circular No. 33, Bureau of Standards, p. 27; "Standard Specifications and Tests for Portland Cement" (Serial Designation: C. 9-17), A. S. T. M. Standards, Adopted in 1916, 436. "Specific Gravity of Non-Homogeneous Aggregates," by Prévost Hubbard and F. H. Jackson, Jr., *Proc. Am. Soc. Testing Materials*, 16, Part II, 380, 1916.

² "Standard Forms for Specifications, Tests, Reports and Methods of Sampling for Road Materials," Bull. No. 555, U. S. Dept. of Agriculture, Wash., D. C., p. 31, Nov. 26, 1917.

Saponification Value (Saponifiable Matter)	Acid Value	Free Fatty Acids	
		Free Resin Acids	
	Lactone Value	Anhydrides and Lactones	
	Ester Value	Neutral Fats	[Glycerol]
Fatty Acids			
Waxes		Fatty Acids	
	Higher Alcohols		
Unsaponifiable Matter	Free Higher Alcohols		
	Hydrocarbons		

The saponification and acid values have been used for distinguishing between native and petroleum asphalts (p. 298), in accordance with the method proposed by J. Marcusson (see p. 545).¹

Test 37a. Free Acids ("Acid Value"). Boil 5.00 g. of the material with 50 c.c. of carefully neutralized 95 per cent ethyl alcohol for 20 minutes.² The liquid is decanted from the insoluble residue while hot, the latter boiled with another 50 c.c. of alcohol, and the process repeated, until the extract no longer reacts acid with alkali blue 6-B (or phenolphthalein). The residue is then disregarded. To the combined extracts, add 10 c.c. of a 25 per cent barium chloride solution and 6 drops of a 3 per cent alcoholic solution of alkali blue 6-B (or an equivalent amount of 1 per cent alcoholic phenolphthalein), and titrate *cold* with standard N/10 caustic potash.³ As the free acids are neutralized by the alkali, the barium soaps are precipitated, and at the same time the unsaponified substances are thrown out by the water contained in the N/10 caustic potash, until at the close of the titration the solution becomes almost clear, rendering the end-point sharp. The acid value is equivalent to the number of milligrams of potassium hydroxide required to neutralize the free fatty acids in 1 g. of the substance.

Test 37b. Lactones and Anhydrides ("Lactone Value"). These are determined as follows: (1) Find the acid value (Test 37a), and the ester value (Test 37c) of the original substance. (2) Find the acid value (Test 37a) and the ester value (Test 37c) of a weighed quantity of the free acids liberated from the substance after saponification (Test 39). If acid and ester values (1) are equal to respective acid and ester values (2); then lactones *only* are present. If acid value (1) is less than acid value (2), and ester value (2) is equal to 0; then glycerides *only* are present. If acid value (1) is less than acid value (2), and ester value (1) is greater than ester value (2); then *both* glycerides and lactones are present.

The true ester value is equal to ester value (1) minus ester value (2); and the true lactone value is equal to ester value (2).

¹ *Z. angew. Chem.*, 24, 1297, 1901.

² Bituminous materials with high fusing-points should be fluxed to semi-liquid consistency with a given weight of neutral paraffine oil.

³ Prepared by dissolving 5.612 g. pure caustic potash in 500 c.c. 95 per cent alcohol, diluting to exactly 1 litre with water at 60° F. and carefully standardizing against sulphuric acid of known strength.

The foregoing results may be checked by finding the acid values of the original substance and the liberated acids. The true ester value equals the acid value of the free acids minus the acid value of the original material. Similarly, the lactone value is equal to the saponification value minus the sum of the acid and ester values.

Test 37c. Neutral Fats ("Ester Value"). The ester value corresponds to the number of milligrams of potassium hydroxide consumed in saponifying esters (neutral fats, otherwise known as triglycerides). If lactones or anhydrides are absent, the ester value may be *calculated* by subtracting the acid value from the saponification value. If lactones and anhydrides are present, then the ester value may be calculated by subtracting the sum of the acid and lactone values from the saponification value.

Test 37d. Saponification Value. The saponification value represents the number of milligrams of potassium hydroxide consumed in the *complete* saponification of 1 g. of the substance. It represents the sum of the acid, lactone and ester values, and is ascertained in the following manner:

Prepare a 5 per cent solution of caustic potash dissolved in equal volumes of 95 per cent ethyl alcohol and 90 per cent thiophene-free benzol, and standardize against sulphuric acid of known strength.¹ Saponify 5 g. of the substance with 50 c.c. of this solution by boiling under a reflux condenser $\frac{1}{2}$ to 1 hour, depending upon the rapidity with which the substance goes into solution. Evaporate the benzol on a water bath, add 100 c.c. water, boil, decant from the residue, add 50 c.c. more water, boil, decant and repeat until all the alkali has been removed (tested by adding a drop of phenolphthalein). Combine the extracts, add 20 c.c. of 25 per cent barium chloride solution ($\text{BaCl}_2 \cdot 2\text{H}_2\text{O}$), and 3 c.c. each of a 1 per cent alcoholic phenolphthalein solution and a 3 per cent alcoholic solution of alkali blue 6-B.² Titrate the warm solution with N. sulphuric acid. As the barium hydroxide becomes neutralized, a copious precipitate of barium sulphate forms which renders the end-point distinct. When the color changes, boil, and if necessary run in more sulphuric acid until the color remains green on boiling. Calculate the quantity of caustic potash required for saponification.

Test 37e. Estimation of Fatty and Resin Acids. If both fatty and resin acids are present in the mixture, it is not a simple matter to separate them quantitatively. The method of procedure consists in first saponifying *a* grams of the substance, sufficient to yield about 5 g. of the mixed acids, and separating the saponifiable matter as described in Test 39. The fatty acids are then separated from the resin acids by the Twitchell-Gladding process as follows:

Dissolve the mixed acids in 50 c.c. absolute alcohol adding any insoluble matter to the separated resin acids subsequently obtained. Cool to 10° C., pass in a stream of dry hydrochloric acid gas for 1 to 2 hours, let stand $\frac{1}{2}$ hour at room temperature, dilute with five volumes of water, boil for 15 minutes under a reflux condenser, cool, and extract the fatty-acid esters and resin acids with benzol. Neutralize the aqueous solution, evaporate to a small bulk, acidify, and again

¹ Approximately 45 c.c. of N. sulphuric acid will be required to neutralize 50 c.c. of the 5 per cent caustic potash solution.

² Marcusson finds that by using the two indicators together, the end point of the titration is sharper, being evidenced by a change in color from red to green.

extract with benzol to remove any traces of acids not previously removed. Combine the extracts, now containing all the fatty-acid esters and resin acids, add 50 c.c. of caustic potash solution (10 g. caustic potash, 10 c.c. ethyl alcohol, and 100 c.c. water) to saponify the free resin acids, and draw off the aqueous layer together with any intermediate layer between the aqueous and benzol layers (containing resin soaps difficultly soluble in the alkaline liquor). Exhaust the aqueous soap solution with benzol to recover any fatty acid esters. The combined benzol extracts are washed in turn with water, twice with 10 c.c. of the potash solution, and finally again with water. The benzol solution containing most of the fatty acids in the form of esters is evaporated to a small bulk, saponified, the free fatty acids liberated with hydrochloric acid, separated and weighed as a check.

The resinous soap solution is united with the various aqueous and alkaline extracts, evaporated to a small bulk, acidified with dilute hydrochloric acid, and extracted with ether to remove the free resin acids. These are evaporated to dryness at 105° C. and weighed. The residue consists of the resin acids contaminated with more or less fatty acids which failed to become esterified. Dissolve in 25 c.c. of 95 per cent alcohol in a 100-c.c. stoppered measuring cylinder, add 2-4 drops of a 1 per cent alcoholic solution of alkali blue 6-B, and neutralize with aqueous caustic soda solution (1 : 2). Heat on a water bath for 15 minutes, cool, dilute to 100-c.c. with ether, agitate, add 1 g. of finely pulverized silver nitrate (dry), and continue the agitation for 15 minutes to convert the fatty-acid soaps into their corresponding silver salts. Settle overnight, decant 75 c.c. of the clear liquid into a separatory funnel, and shake with 20 c.c. dilute hydrochloric acid (1 : 2). Draw off the ether layer, and extract the aqueous solution with two 20 c.c. portions of ether. Combine the ether extracts, wash with 20 c.c. water, filter into a tared crucible, evaporate to dryness at 105° C., weigh and add to the residue insoluble in alcohol mentioned above. The total residue consists of the practically pure resin acids (*b* grams).

Per cent resin acids in original substances = $\frac{4b}{3a} \times 100$. Since resins carry an average of 8 per cent unsaponifiable constituents, their percentage may be approximately calculated as follows:

$$\text{Per cent resin in original substance} = \frac{144b}{a}.$$

Test 38. Asphaltic Constituents. The methods which follow have been proposed by J. Marcusson¹ for differentiating between native and petroleum asphalts (p. 298). They also give an insight into the composition of asphalts themselves, and in this respect the author regards them of special merit. The value and possibilities of these determinations do not appear to be generally appreciated, but as time goes on they will certainly be recognized. The figures in table on page 546 will illustrate their utility; the results for crude Trinidad and refined Bermudez asphalt are reported by Marcusson, the balance having been obtained by the author.

¹ *Z. angew. Chem.* **29**, 346, 1916,

	Non-mineral Constituents of Crude Trinidad Asphalt.	Refined Bermudez Asphalt.	Fluxed Graham- ite.*	Residual Asphalt from Mex- ican Petroleum.	Blown Asphalt from Asphaltic Petroleum.	Hard Sludge Asphalt.	Residual Oil from Mixed- base Petroleum.
Fusing-point (K. and S. method)...	132° F.	135° F.	161° F.	160° F.	165° F.	180° F.	80° F.
Free asphaltous acids	6.4%	3.5%	0.90%	0.61%	1.87%	0.81%	0.92%
Asphaltous acid anhydrides.....	3.9%	2.0%	1.28%	Trace	0.25%	1.61%	0.46%
Asphaltenes.....	37.0%	35.3%	17.28%	5.81%	Trace	27.01%	Trace
Asphaltic resins...	23.0%	14.4%	30.75%	26.72%	16.66%	25.68%	25.34%
Oily constituents..	31.0%	39.6%	48.50%	65.45%	80.57%	44.09%	74.59%

* Composed of 15 per cent grahamite and 85 per cent residual oil derived from asphaltic petroleum.

Test 38a. Free Asphaltous Acids. Dissolve 5.00 g. of the asphalt in 25 c.c. benzol by boiling under a reflux condenser. Add 200 c.c. ethyl alcohol, let settle, decant the solution from the pitchy residue, and titrate the former cold with N/10 alcoholic sodium hydroxide, using phenolphthalein as indicator. Dilute with an equal volume of water and extract the unsaponifiable constituents by shaking with successive portions of benzol until the extract becomes clear. Evaporate the alcoholic soap solution to a small bulk, liberate the asphaltous acids by acidifying with hydrochloric acid, extract with benzol, evaporate the extract to dryness at 100° C. and weigh. The free asphaltous acids appear as a tar-like to resinous mass, soluble in alcohol, benzol and chloroform, but nearly insoluble in 88° petroleum naphtha. When heated to 120° C. they are converted into the corresponding anhydrides.

Test 38b. Asphaltous Acid Anhydrides. In the foregoing test, the unsaponified portion is united with the pitchy substances precipitated by alcohol from the original benzol solution. These are saponified by boiling under a reflux condenser for 1 hour with N-alcoholic caustic potash in the presence of benzol, the solution is diluted with an equal volume of water, and the unsaponified constituents extracted with successive portions of benzol. The alcoholic soap solution is then evaporated to a small bulk, the asphaltous acid anhydrides liberated by acidifying with hydrochloric acid, extracted with benzol, evaporated to dryness at 105° C. and weighed. These are very similar in appearance to the free asphaltous acids. On heating to high temperatures, they are converted into unsaponifiable products similar in appearance to the asphaltenes.

Test 38c. Asphaltenes. After separating the saponifiable constituents according to Tests 38a and 38b, the bodies which have not combined with alkali are dissolved in the smallest possible quantity of benzol (not exceeding 10 c.c.), and the solution poured into 200 c.c. of 88° petroleum naphtha.¹ The insoluble matter is filtered on a Gooch crucible as described in Test 23, washed with 88° naphtha, dried and weighed. This represents the asphaltenes, which appear as a dark brown to black powder similar to grahamite in characteristics. On heating it does not melt, but swells and decomposes into a compact and hard coke. Asphaltenes are supposed to be formed by the addition of oxygen or sulphur to petroleum resins, also to inter-molecular changes taking place on heating them in air. They are soluble in

¹ Of which at least 85 per cent by volume should distil between 35 and 65° C.

benzol, chloroform and carbon disulphide, almost completely insoluble in alcohol and 88° petroleum naphtha, and sparingly soluble in ether and acetone. They are characterized by a high percentage of sulphur (7-13 per cent) and under the influence of light are converted into an insoluble modification (p. 574). The asphaltenes and their parent substances, the asphaltic resins, are regarded as saturated polycyclic compounds containing sulphur or oxygen, either of which can replace the other.

Test 38d. Asphaltic Resins. The solution of 88° petroleum naphtha obtained from Test 38c is evaporated to about 25 c.c., distributed over 25 g. fuller's earth in a paper thimble, and extracted hot in a Soxhlet with 88° petroleum naphtha. If the first extract is dark colored, it is concentrated to about 25 c.c., poured over more fuller's earth, and the process repeated. The extract should have a straw or light yellow color. The asphaltic resins are retained by the fuller's earth, from which they may be extracted by carbon disulphide, evaporated to dryness at 100° C., and weighed. These form the first stage in the conversion of petroleum hydrocarbons into asphaltenes, and consist of solid, reddish-brown to brownish-black substances fusing below 100° C., completely soluble in 88° naphtha, chloroform, carbon disulphide, benzol, but only sparingly soluble in hot or cold acetone. After absorption by fuller's earth they become insoluble in 88° petroleum naphtha. The asphaltic resins are formed by heating the oily constituents for some time to 120° C. accompanied by a darkening in color and absorption of atmospheric oxygen.

Test 38e. Oily Constituents. The 88° petroleum naphtha extract from the fuller's earth in Test 38d, is distilled to a small bulk, and evaporated to dryness at 100° C. until the odor of petroleum naphtha is no longer apparent. The oily constituents remaining as residue are weighed. These appear as a viscous oil, and constitute the most inert bodies contained in asphalts. As a general rule, the softer the asphalt, the larger will be the percentage of oily constituents. Marcusson reports that Trinidad petroleum contains 42 per cent of oily constituents, Trinidad asphalt 17 to 19 per cent (figured on the crude dry substance containing the mineral ingredients) and grahamite 2 to 3 per cent.

Test 39. Estimation of Unsaponifiable and Saponifiable Matters. In the case of bituminous materials, the estimation of the unsaponifiable and saponifiable matters is of value for purposes of identification. Certain bituminous substances, such as montan wax, rosin pitch, and fatty-acid pitch are often composed largely of saponifiable constituents. Others, including pine tar, pine-tar pitch, hardwood tar, hardwood-tar pitch, peat tar, lignite tar, bone tar, bone-tar pitch and other forms of fatty-acid pitches contain smaller percentages. This test is also used for gauging the uniformity of supply, and in the case of fatty-acid pitches, as a criterion of the quality.

The following procedure has been devised by the author for specifically examining bituminous materials or admixtures of bituminous materials with animal or vegetable oils and fats, since the customary methods do not adapt themselves especially well, due to the formation of troublesome emulsions. The bituminous material is first freed from insoluble constituents, including any mineral matter, by boiling with benzol under a reflux condenser, cooling and filtering through a

Gooch crucible, following the precautions described in Test 21a. The insoluble constituents are dried at 100° C. and weighed. Sufficient of the bituminous substance should be taken to yield approximately 5.0 g. of extract. The benzol solution is evaporated or distilled to 50 c.c., and 50 c.c. of the saponifying liquid added from a pipette. This should consist of a 10 per cent solution of caustic potash, prepared by dissolving 100 g. of anhydrous potash in 500 c.c. of 95 per cent ethyl alcohol, and diluting to a litre with 90 per cent benzol. The liquid is allowed to stand overnight to permit any carbonate to settle, and the clear solution decanted. After the saponifying agent is added, the mixture is boiled under a reflux condenser, for $\frac{1}{2}$ -1 hour, and the contents of the flask while still warm poured in a separatory funnel containing 150 c.c. of boiling water and 25 c.c. of a 10 per cent solution of potassium chloride. Add 250 c.c. of benzol, agitate vigorously, and allow the funnel to rest quietly in a warm place until the solvent separates. If an emulsion forms which refuses to separate on standing, add 200 c.c. more benzol and 100 c.c. 95 per cent ethyl alcohol and stand in a warm place overnight. This will invariably effect a more or less complete separation of the solvent. From this point on the method is illustrated by the following tabular outline:

Saponify as described:

Draw off the soap solution as completely as possible.

Decant the benzol layer, leaving the intermediate layer in the separatory funnel.

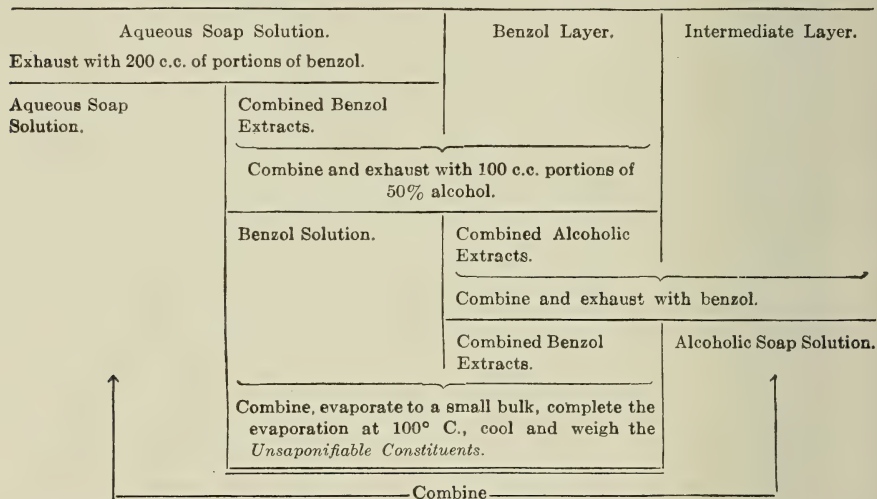

Transpose with dilute hydrochloric acid, warm and exhaust with benzol. Separate the aqueous solution containing the glycerol and mineral salts. Evaporate the combined benzol extracts to a small bulk, and then complete the evaporation of solvent at 100° C. Cool and weigh. Weight equals the free acids derived from the saponifiable constituents.

In the case of bituminous materials that are more or less completely saponifiable, the intermediate layer is apt to be absent. In this case the process will simplify itself considerably. The foregoing procedure will separate the unsaponifiable constituents in practically an ash-free state.

Test 39a. Hydrocarbons. Boil 2 g. of the unsaponifiable matter with 4 c.c. of acetic anhydride under a reflux condenser for 1 hour. Add 25 c.c. of 95 per cent

ethyl alcohol, heat to boiling, decant through an asbestos Gooch crucible, and remove all traces of acetic anhydride by washing with successive portions of warm alcohol. Dry the residue on the Gooch at 100° C. Its weight is equal to the hydrocarbons present.

Test 39b. Higher Alcohols ("Cholesterol"). The filtrate from the foregoing (Test 39a) is evaporated to dryness, then dissolved in the smallest possible quantity of hot absolute ethyl alcohol and allowed to cool. The cholesterol and phytosteryl (sometimes termed sitosteryl) will crystallize as acetates. Filter and wash with 95 per cent alcohol. Find the melting-point by the capillary tube method as ordinarily used for pure organic substances. Cholesterol acetate will melt between 114.3 and 114.8° C., whereas phytosteryl acetate will melt above 125° C. Recrystallize several times from hot absolute alcohol and redetermine the melting-point. If the fifth to seventh crop of crystals tests below 115–116° C., then phytosteryl is absent.

Cholesterol may also be detected by boiling 1 g. of the substance with 2 c.c. of chloroform and 20 drops of acetic anhydride. The solution is allowed to cool and the clear liquid decanted into a porcelain crucible. Then 1 drop of concentrated sulphuric acid is added to the liquid. If cholesterol is present, a violet-pink to reddish coloration will be obtained. (For the behavior of resin acids in the foregoing test, see Test 43.)

Cholesterol indicates the presence of *animal* oils, fats or waxes (such as wool grease), whereas phytosteryl indicates *vegetable* oils, fats or waxes. This test is therefore of value in detecting which class of substances is present in admixture with bituminous material.

Test 40. Glycerol. Glycerol indicates the presence of animal and vegetable oils or fats (triglycerides). Certain fatty-acid pitches also contain a small percentage of glycerol (see p. 331). This test is of special importance in the examination of bituminous paints, cements, varnishes and japons (p. 572.)

Saponify 5–10 g. of the substance under examination, weighing exactly, and using 25 c.c. of the saponifying agents described in Test 39. Extract the unsaponifiable constituents with benzol as described, and then transpose the soap solution with a *slight* excess of dilute sulphuric acid (instead of using hydrochloric acid). Warm the liquid and extract the fatty acids with benzol.

Evaporate the aqueous solution to a small bulk, and make slightly alkaline with dilute caustic soda. Cool, dilute to about 100 c.c. and determine glycerol by any of the standard methods proposed for this purpose.¹

Test 41. Diazo Reaction. This test is used for identifying bituminous substances carrying phenols, including wood tar and wood-tar pitch, oil-gas- and water-gas-tars and pitches, shale tar, peat- and lignite-tars and pitches, bone tar, bone-tar pitch and the various coal-tar pitches.

This reaction was devised by E. Graefe.² It is carried out by boiling 2 g. of

¹ "Aids in the Commercial Analysis of Oils, Fats, etc.," by G. F. Pickering, London, 1917; "Analysis of Crude Glycerin," by the International Standard Methods, *J. Soc. Chem. Ind.*, **30**, 556, 1911.

² "Distinction between Lignite Pitch and other Pitches," *Chem. Zeit.*, **30**, 298, 1906; Marcusson and Eickmann, *Chem.-Zeit.*, **32**, 965, 1908.

the bituminous substance with 20 c.c. N. aqueous caustic soda, for approximately 5 minutes. After cooling, the liquid is filtered. If the filtrate is dark colored, it may be lightened by adding finely pulverized "salt." It is then cooled in ice, and a few drops of freshly prepared diazobenzolchloride solution (prepared by treating anilin with hydrochloric acid and sodium nitrite) added. If phenols are present a red coloration will result, sometimes accompanied by a reddish precipitate.

Assuming that the bituminous substance gives the diazo reaction, the question will often arise whether the product is a straight-distilled pitch, or an asphalt "cut-back" with a high boiling-point distillate containing phenolic bodies, derived from coal tar, lignite tar, etc. Marcussen has worked out a method applicable under these circumstances,¹ which consists in dissolving 10 g. of the bituminous substance in 15 c.c. of benzol, and pouring the solution into 200 c.c. of 88° petroleum naphtha. The resulting precipitate is washed with petroleum naphtha and dried. It is then boiled for 15 minutes with N/2 alcoholic caustic potash under a reflux condenser to extract the phenols. The liquid is cooled and filtered, the alcohol evaporated, and the residue dissolved in water. Sodium chloride is added to clarify the liquid and remove any substances imparting a dark color, the solution is filtered and the filtrate treated for the diazo test described above. If a straight distilled pitch containing phenols is present, a positive reaction will be obtained. If the original substance gives the diazo test, but the residue treated in the above way does not, then the admixture of high boiling-point oils containing phenolic bodies with a substance free from phenols (e.g. asphalts, etc.) is established. It is claimed that the presence of 10 per cent asphaltic substances may be detected in this manner.

Where bituminous substances contain calcium carbonate, the phenolic bodies present combine with the lime, forming insoluble calcium phenolate which yields but a faint diazo reaction. However, on treating such substances with a solvent in the presence of hydrochloric acid, the calcium phenolate is decomposed, and the diazo reaction becomes much more delicate.

Test 42. Anthraquinone Reaction. The anthraquinone reaction is used for detecting anthracene in tar products produced at high temperatures, including oil-gas-tar and pitch, water-gas-tar and pitch, and the various coal-tar pitches. This test is therefore valuable for purposes of identification.

The tar or pitch is first subjected to distillation in accordance with the retort method (Test 20b), the ofttake and condensing tube being kept warm to prevent the accumulation of any solid distillate. The distillate passing over between 270 and 355° C. is caught separately and examined for anthracene in the following manner. The fraction is heated until it is thoroughly fluid to secure a uniform sample, and 5 g. weighed out, while hot. After cooling, 10 c.c. of absolute ethyl alcohol are added, the solids allowed to crystallize and the liquid decanted. The solid substances containing the anthracene are dried on a water bath, transferred to a 500-c.c. flask connected with a return condenser, 45 c.c. of glacial acetic acid added, and the contents boiled for 2 hours. The following mixture is then added drop by drop through a separatory funnel, viz.: 15 g. of anhydrous chromic acid dissolved in 10 c.c. of glacial acetic acid, and 10 c.c. of water. The boiling is

¹ *Chem. Rev. Fett-und Harz-Ind.*, 18, 47, 1911.

continued for another 2 hours, the flask cooled, and 400 c.c. cold water added. This treatment oxidizes the anthracene to anthraquinone, which on cooling separates as a solid mass. This is filtered, washed with hot water, then with a hot 1 per cent solution of caustic soda and again with hot water. The residue of anthraquinone is then dried and its weight multiplied by 0.856 to obtain the corresponding weight of anthracene. From 0.25 to 0.75 per cent of anthracene is found in coal tars, and a corresponding larger percentage in coal-tar pitches.

A color reaction for establishing the presence of anthracene consists in boiling the crystals of anthraquinone with zinc dust and caustic soda solution, whereupon an intense red colored solution is obtained, which on filtering in contact with air becomes decolorized.

Test 43. Liebermann-Storch Reaction. This is a rapid qualitative test for detecting the presence of rosin, rosin oil, or cholesterol. One gram of the substance is dissolved in 3 c.c. of acetic anhydride at a gentle heat, cooled and the clear liquid decanted into a porcelain crucible. Add 1 or 2 drops of sulphuric acid sp.gr. 1.53 (containing 62.53 per cent of pure sulphuric acid, prepared by diluting 34.7 c.c. of concentrated sulphuric acid with 35.7 c.c. of water). Rosin and rosin oil will produce a fugitive violet coloration turning to a brown, whereas cholesterol will produce a fugitive rose color turning rapidly to a dark green. If rosin or rosin oil is present in conjunction with cholesterol, the test becomes valueless.

Fossil resins (copals, etc.) also fatty-acid pitches give a permanent brown color and do not interfere with the foregoing test. Linseed, cotton-seed, china-wood and corn oils give a permanent greenish-brown coloration, whereas palm oil, bone tar, and crude olein give a permanent brownish-yellow coloration.

CHAPTER XXXII

METHODS OF TESTING MANUFACTURED PRODUCTS

THIS chapter will include methods for analyzing and testing manufactured products, containing in addition to bituminous substances, materials of a non-bituminous character, such as mineral aggregates, mineral, animal or vegetable fibres, fabrics, water in the form of emulsion, volatile solvents, animal and vegetable fats or oils, colored pigments, etc. The tests about to be described will accordingly supplement those embodied in Chapters XXVIII to XXXI inclusive, which were restricted to examining crude, refined or blended bituminous substances, without other additions.

BITUMINIZED MINERAL AGGREGATES

Products falling into this class include native and artificial mixtures of bituminous matter with mineral aggregates, viz: bituminous macadam pavements, bituminous concrete pavements, sheet asphalt pavements, asphalt block pavements, asphalt mastic floorings, bituminous expansion joints (containing mineral matter but not felt), pipe-sealing compounds, moulding compositions and products used for electrical insulation.

Effect of Moisture. Various methods have been suggested from time to time for ascertaining the water absorption of paving materials.¹ It is recognized that all pavements absorb more or less moisture, but no standard method has been proposed for this purpose. Richardson suggests the use of cylinders of the same dimensions as used for the impact test (p. 555) namely 1.25 in. in diameter, by 1 in. high, having the greatest possible density, which in the case of surface mixtures for sheet asphalt pavements, will weigh about 50 g. They are immersed in water for 3 months, and the gain in weight noted at various intermediate periods. This same method will adapt itself for testing asphalt block pavements and asphalt mastic floorings.

The following tentative methods have been proposed for testing the water absorption of moulded insulating materials.² One-half of the standard briquette

¹ Whipple & Jackson, *Eng. News*, 47, 1900; "The Testing of Bitumens for Paving Purposes," by A. W. Dow, *Proc. Am. Soc. Testing Materials*, 3, 368, 1903; *Eng. News*, 51, 520, 1904; "The Modern Asphalt Pavement," 2nd Edition, Chapter XXIV, 461.

² "Tentative Tests for Molded Insulating Materials" (Serial Designation: D 48-17 T), *Proc. Am. Soc. Testing Materials*, Part I, 790, 1917.

used for ascertaining the tensile strength of moulded insulating materials (Fig. 193) shall be used for this purpose. All loose particles are removed, and the specimen dried for 24 hours either in a desiccator or in an oven at 100° C. It is then cooled, reweighed, and immersed in distilled water for 100 hours at 77° F. At the end of this time, the specimen is removed, wiped dry with a cloth and reweighed. The following figures should be recorded; viz.: the original weight of the specimen; its dry weight; the saturated weight in grams after 100 hours' immersion; the percentage of moisture as received; the percentage of moisture absorbed during the

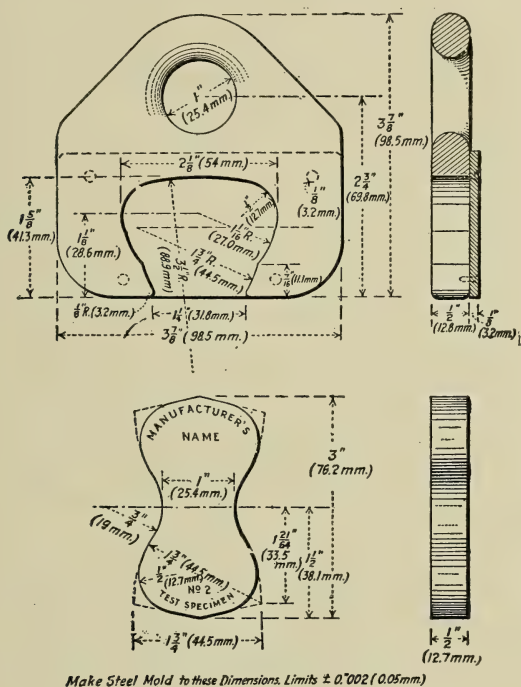

From A. S. T. M. Tent. Standards.
 Fig. 193.—Mould for Ascertaining the Tensile Strength of Bituminized Aggregates.

100 hours, taking the dry weight as 100 per cent. The average for three specimens is reported.

Tensile Strength. The following tentative test has been proposed for moulded insulating materials,¹ but may also be adapted to testing the surface course of sheet asphalt pavements, asphalt mastic floorings, expansion joints (not containing fabric), pipe-sealing compounds, etc. The specimen is cast under pressure to obtain the greatest possible density, in a hardened and ground steel mould of the dimensions shown in Fig. 193, then immersed in distilled water for 48 hours at 77° F., removed, wiped dry and pulled apart on any standard testing machine in air at 77° F.,

¹ "Tentative Tests for Molded Insulating Materials" (Serial Designation: D 48-17 T), *Proc. Am. Soc. Testing Materials*, Part I, 778, 1917.

at a speed that will enable the beam to be well balanced. The results of the test shall be reported in the following order, viz.: the breaking load in kilograms or pounds; the thickness in centimeters or inches as measured by a micrometer at the point of fracture; the ultimate tensile strength in kilograms per square centimeter or in pounds per square inch as calculated from the actual area of the specimen at the point of fracture; the speed in centimeters or inches per minute at which the jaws travel during the test. Three such tests should be averaged.

Compressive Strength. This test has likewise been proposed for moulded insulating materials,¹ and is adapted to all bituminized mineral aggregates in which the particles do not measure over $\frac{1}{4}$ in. in diameter. A 1-in. cube is moulded under pressure in a hardened steel mould to attain the greatest possible density, and immersed in distilled water at 77° F. for 48 hours. Wipe the surface dry and place sheets of lead $\frac{1}{16}$ in. thick both above and below the specimen to adjust irregularities. Any standard testing machine may be used, and the load shall be applied at such a rate of speed as will permit the beam to be kept well balanced. The results of the test shall be reported as follows, viz.: the dimensions of the specimen in millimeters or inches; the breaking load in kilograms or pounds at the first sign of failure; the average ultimate compressive strength in kilograms per square centimeter or pounds per square inch, calculated from the measured area of the specimen before the load is applied; the speed in centimeters or inches per minute at which the jaws travel during the test. Three such tests are averaged.

Transverse Strength. This test is similarly intended for moulded insulating materials,² but may also be applied to bituminized aggregates containing finely divided mineral matter, as in the tensile strength test.

The material shall be compressed to the greatest possible density in a hardened steel mould, ground so its internal dimensions will measure exactly $\frac{1}{2}$ in. by $\frac{1}{2}$ in. by 5 in. The specimen is tested at 77° F. after immersion in distilled water at 77° F. for 48 hours, all surface water having been removed with a dry cloth, and supported on two steel blocks with corners rounded to $1\frac{1}{2}$ mm. radius, spaced exactly 100 mm. apart, and at equal distances from the ends of the specimen. The load is applied by a wedge-shaped pressure piece, the edge of which is rounded to a 3 mm. radius, extending across the specimen with the edge parallel to the edges of the two supports. The angle of the wedge shall be approximately 45°, and the load applied as slowly as possible at right-angles to the specimen, midway between the supports. The results shall be reported in the following manner, viz.: the thickness of the specimen in millimeters or inches; the actual breaking load in kilograms or in pounds at the first sign of failure; the maximum fibre stress in kilograms per square centimeters or in pounds per square inch calculated by the formula

$$S = \frac{3PL}{2BD^2},$$

where S represents the maximum fiber stress, P the load applied, L the distance between the supports, B the width of the specimen, and D the depth of the specimen. The rate at which the load is applied is also recorded, also the amount of deflection in millimeters or inches.

¹ "Tentative Tests for Molded Insulating Materials" (Serial Designation: D 48-17 T), *Proc. Am. Soc. Testing Materials*, Part I, 780, 1917.

² "Tentative Tests for Molded Insulating Materials" (Serial Designation: D 48-17 T), *Proc. Am. Soc. Testing Materials*, Part I, 782, 1917.

Impact Test. This test was originally devised by L. W. Page for testing the toughness of rock for road building,¹ having since been adapted by Richardson for testing bituminous aggregates.² The bituminous mixture is heated to the lowest possible temperature that will permit it being manipulated, and formed by compression into a cylinder 25 mm. high by 24–25 mm. in diameter, the ends of which shall be plane surfaces at right angles of its axis. The hot bituminous mixture is compressed in a hollow cylindrical steel mould, 24–25 mm. in diameter by 50 mm. long, having an accurately fitting steel plunger. The mould is loosely filled with the hot bituminous mixture and compressed with the plunger by sharp blows of a heavy hammer from the top and bottom respectively, until it is thoroughly compacted. The cylinder of bituminous material is then knocked from the mould and sawed off or ground down until it measures exactly 25 mm. high. The density of the specimen should be noted and reported. It shall be maintained in water at 77° F. for 48 hours, wiped dry, and tested in air at a temperature of 77° F. on any form of impact machine which will comply with the following essentials:³

(a) A cast-iron anvil weighing not less than 50 kg. firmly fixed upon a solid foundation.

(b) A hammer weighing 2 kg. arranged to fall freely between suitable guides.

(c) A plunger of hardened steel weighing 1 kg. arranged to slide freely in a vertical direction in a sleeve, the lower end of the plunger being spherical, with a radius of exactly 1 cm.

(d) Means for raising the hammer and dropping it upon the plunger from any specified height from 1 to not less than 75 cm.

(e) Means for holding the cylindrical test-specimen securely on the anvil without rigid lateral support, and under the plunger in such a way that the centre of its upper surface shall, throughout the test, be tangent to the spherical end of the plunger at its lowest point.

The test shall consist of a 1 cm. fall of the hammer for the first blow; a 2 cm. fall for the second blow; and an increase of 1 cm. for each succeeding blow, until failure of the test specimen occurs. The number of blows required to shatter the test-piece is taken to represent the toughness, three such tests being averaged. Tests are performed at three temperatures, viz.: 32° F., 77° F. and 115° F.

Distortion under Heat. This test is applicable to bituminized mineral aggregates whose particles do not exceed $\frac{1}{4}$ in. in diameter, the same test specimen being used as in the transverse test (p. 554).⁴

The apparatus used for this purpose is illustrated in Fig. 194. The specimen should rest on steel supports 100 mm. apart, and the load applied on top of the specimen vertically and midway between the supports, as in the transverse strength test. The machine shall be arranged to apply two different loads, viz.: 2.5 kg. and 5.0 kg. The specimen is placed in an air bath surrounded by an oil bath, the temperature of which is increased at a rate of exactly 1° F. per minute. The deflection of the specimen at its centre between the supports is measured on a

¹ Bulletin No. 79, Bureau of Chem., U. S. Dept. of Agr., Wash., D. C.; Bulletin No. 44, Office of Public Reads, U. S. Dept. of Agr., Wash., D. C., June 10, 1912.

² "The Modern Asphalt Pavement," 2nd Edition, 1908, pp. 428 and 585.

³ "Tentative Tests for Molded Insulating Materials" (Serial Designation: D 48-17 T), *Proc. Am. Soc. Testing Materials*, **17**, Part I, 773, 1917.

⁴ "Tentative Tests for Molded Insulating Materials," (Serial Designation: D 48-17 T), *Proc. Am. Soc. Testing Materials*, **17**, Part I, 787, 1917.

scale in millimeters or mils. The distortion point shall be considered the temperature at which the specimen has deflected 10 mils. The results of the test are reported as follows, viz.: the distortion point in degrees F.; the time required for the specimen to deflect 10 mils starting at 77° F.; curves are plotted, showing the minutes horizontally, and the corresponding deflection, also the temperature at given intervals vertically.

Softening-point. An ingenious apparatus for determining the softening-point of moulded insulating materials, which is likewise adapted to testing pavements, asphalt mastic floorings, expansion joints and pipe-sealing compounds, has been

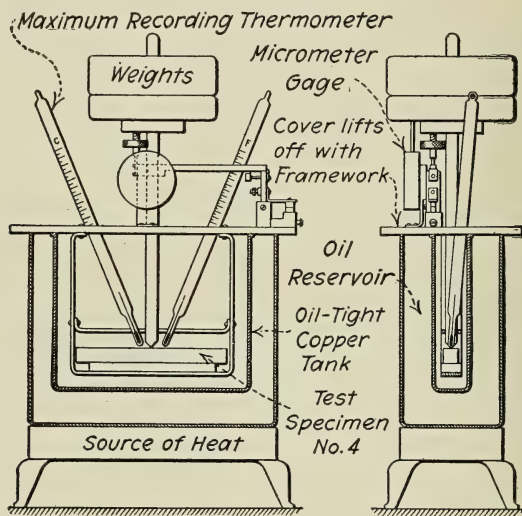

From A. S. T. M. Tent. Standards.

FIG. 194.—Apparatus for Recording Distortion of Bituminized Aggregates under Heat.

devised by H. R. Edgecomb¹ as illustrated in Fig. 195. The underlying principle consists in comparing the expansion with the tendency to soften as the temperature increases. The apparatus consists of an electrical heater 1, a plate or slab 2 above the heater, a hood 3 for retaining the heat, a rod 4 having a relatively large lower face resting loosely on the specimen, a rod 5 having a relatively small lower face (0.01 sq.in. in area) actuated by a weight 6 of either 2.5 or 5.0 kg., and an opening 7 for the thermometer 8. The rods and thermometer rest upon the insulating material 9 to be tested, and each of the rods 4 and 5 is provided with a scale 10 operating in conjunction with stationary vernier scales 11, for recording the movement.

It is important that the sample 9 be provided with two plane faces, also that the temperature is increased at the uniform speed of 1° F. per minute. The positions of the rods 4 and 5 are noted at periodic intervals, and two curves plotted with the temperature as abscissas and the movement of the rods respectively in thousandths

¹ U. S. Pat. 1,184,837 of May 30, 1916, "Device for Testing Plastic Materials."

of an inch as ordinates. These curves will be identical as the material expands throughout a certain range in temperature, but when it begins to soften rod 5 will change its direction of travel, and instead of moving upward will embed itself in the sample. The point at which the two curves diverge represents the softening-point of the material. This is shown at 60° F. in the chart illustrated in Fig. 195.

Separation of the Bituminous Matter and Mineral Aggregate. Bituminized aggregates are often separated into their bituminous and mineral components for the combined purposes of ascertaining the percentage and nature of the mineral constituents, and for examining the physical and chemical characteristics of the bituminous binder, with the object of its identification or duplication. Two methods are used, including the hot extraction process devised by Forrest, and the centrifugal extraction method.

Forrest's Hot Extraction Method.

The bituminous mixture should first be warmed until it may be broken apart without fracturing the mineral particles. The extraction is performed in an apparatus illustrated in Fig. 196, consisting of a cylindrical brass jacket surrounding an incandescent-light bulb to supply the necessary heat, and enclosing a brass vessel for holding the solvent, which in turn carries a cylindrical basket composed of 80 mesh-wire cloth for retaining the sample. Cold water is circulated through the inverted conical condenser, which also serves to cover the apparatus. Weigh out 500 g. of material if the mineral particles are coarser than $\frac{1}{2}$ in., or 300 g. if they are finer than $\frac{1}{2}$ in. Place it in the basket and cover with a pad of cotton or felt $\frac{1}{4}$ – $\frac{1}{2}$ in. thick. Pour 175–200 c.c. of carbon disulphide into the inner vessel, insert the cover and start the extraction by turning on the incandescent light. The extraction is usually completed in 3 hours' time, whereupon the apparatus is cooled, the basket containing the mineral aggregate removed, dried in an oven and weighed. Any fine mineral particles passing through the 80-mesh sieve constituting the basket are recovered by filtering the extract through a weighed asbestos Gooch filter as described in Test 21a, washed clean with carbon disulphide, dried and weighed. This method is used where the bituminous matter is to be separated in a pure state for further examination. An alternate method consists in measuring the extract in a glass graduate, thoroughly agitating it and pouring an aliquot portion into a tared crucible or dish, evaporating the solvent,

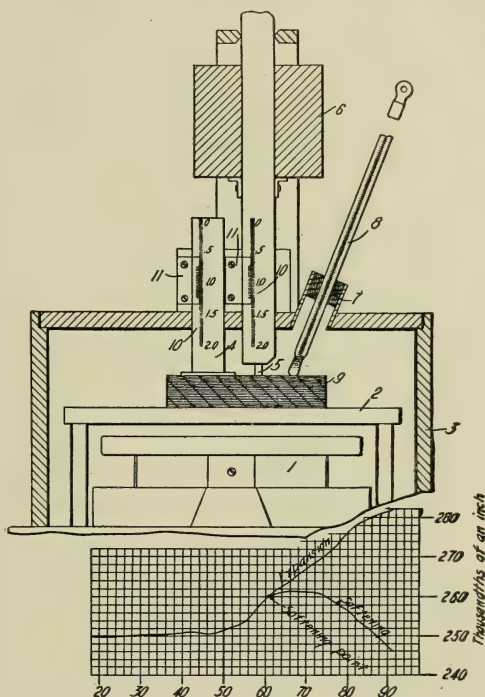
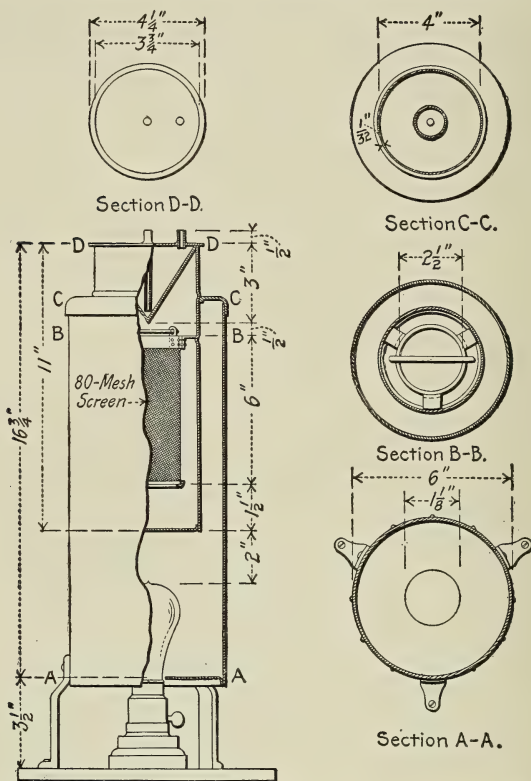

FIG. 195.—Apparatus for Determining the Softening-point of Bituminized Aggregates.

burning the residue and igniting to ash. The fine mineral matter present in the entire extract may be calculated from the ash derived from the portion ignited.



From A. S. T. M. Proc.

FIG. 196.—Forrest's Hot-extraction Apparatus.

The total should be added to the coarser mineral aggregate previously separated, to arrive at the percentage present.¹

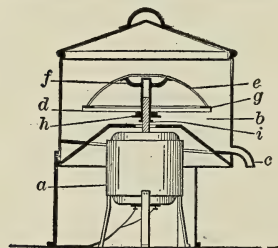

FIG. 197.—Centrifugal Extractor.

Centrifugal Method. The most efficient apparatus of this type was designed by C. S. Reeve,² as illustrated in Fig. 197. It consists of a $\frac{1}{8}$ h.p. vertical motor *a*, capable of making 1100 revolutions per minute at 110 volts, with either direct or alternating current. Its shaft projects into a cylindrical copper vessel *b*, having a concave bottom and draining into the spout *c*. A circular brass plate *d*, 9 $\frac{1}{2}$ in. in diameter supports an inverted iron bowl *e*, 8 $\frac{1}{2}$ in. in diameter by 2 $\frac{5}{16}$ in. high, having a 2 in. circular hole at the top. A brass cup *f* is fastened to the inner side of the bowl, having

¹ "Extractor for Bituminous Paving Mixtures," by C. N. Forrest, *Proc. Am. Soc. Testing Materials*, **13**, 1069, 1913.

² "Laboratory Manual of Bituminous Materials," 1st Edition, N. Y., 1916, p. 108.

a circle of $\frac{1}{8}$ in. holes for the admission of solvent, and terminating in a hollow axle which fits snugly through a hole in the centre of the brass plate *d*. A felt ring *g*, $\frac{3}{4}$ in. wide and about 0.090 in. thick (cut from No. 80 roofing felt) is firmly pressed against the bowl by the milled nut *h* for which the hollow axle is suitably threaded. The axle in turn fits snugly over the shaft of the motor, to which it is secured by a slot and cross-pin.

Weigh 300–500 g. of the bituminous mixture, broken up as previously described, into the bowl *e*, place the felt ring on the rim of the plate *d*, and bolt them together with the nut *i*. After assembling the apparatus, pour 150 c.c. of carbon disulphide into the bowl through the small holes, place the cover over the copper box *b*, and slowly start the motor, gradually increasing its speed until the carbon disulphide extract flows in a thin stream from the spout *c* into an empty flask underneath. When the first charge has drained, the motor is stopped, fresh carbon disulphide added, and the operation repeated 4 to 6 times until the extract runs clear. The bowl is then removed, inverted, the nut unscrewed, and any carbon disulphide retained by the mineral matter allowed to evaporate spontaneously. The mineral matter is then dried and weighed. It is well to filter the extract through a Gooch crucible to recover any mineral matter which may have worked its way through the felt ring, adding same to the balance of the mineral matter.

Recovery of Extracted Bituminous Matter.

From the weight of the extracted mineral matter, calculate the bituminous matter by difference, and evaporate the carbon disulphide extract to exactly this weight. This may be conveniently performed by distilling and condensing most of the carbon disulphide over an incandescent light or an electric stove. The concentrated solution is transferred to a tared dish, evaporated dry on a steam bath, and the last traces of solvent removed in an oven at 105° C. until the residue attains the calculated weight. The bituminous matter may then be examined further, according to any of the tests described in Chapters XXVII to XXXI inclusive. Due allowance should be made for the fact that any non-mineral matter insoluble in carbon disulphide (Test 21*b*) will be retained mechanically by the extracted mineral matter, which with asphaltic products is relatively unimportant, but will amount to a considerable item in the case of tar products (see table p. 483).

Examination of the Recovered Mineral Aggregate. The presence of any non-mineral matter insoluble in carbon disulphide will be revealed by the discoloration

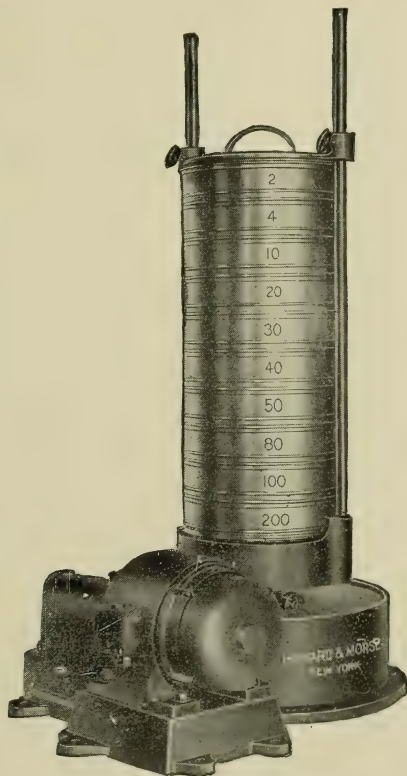

Courtesy of Howard & Morse.

FIG. 198.—Mechanical Sifting Apparatus.

of the mineral particles. In this case, the weight of the latter should be corrected by igniting it until all carbonaceous matter is destroyed, and then reweighing. The mineral matter may be examined further by Tests 36c, 36e and 36f (page 539). A convenient apparatus for the granulometric analysis (Test 36e) is illustrated in Fig. 198, designed by Forrest.¹

BITUMINIZED FABRICS

The finished products falling in this class include sheet roofings, floor coverings, waterproof membranes, sheathing and insulating papers, expansion joints involving the use of woven or felted fabrics, electrical insulating tape, and certain types of wall board (p. 386). As these are constructed in many different ways, it will obviously be impracticable to describe in detail the analytical methods applicable to each. The ones which follow have been devised by the author specifically for examining prepared roofings,² but with these as a starting-point, others may readily be evolved for testing floor coverings, waterproof membranes, sheathing and insulating papers, etc.

For all practical purposes, prepared roofings may be divided into the six types illustrated in Fig. 199.

Type A represents a layer of felt saturated and coated with bituminous matter. The surface coatings may be either finished plain or dusted with very fine mineral matter, and they may be either applied smooth and level or with a veined appearance (Fig. 122).

Type B is similar to Type A, but surfaced on *both* sides with moderately coarse mineral matter embedded superficially in the coatings (Fig. 124).

Type C is similar to Type A, but surfaced on *one* side with coarse mineral matter embedded in the coating (Figs. 125-127).

Type D is composed of a layer of saturated felt and a layer of burlap or cotton duck cemented together and coated on top and bottom with bituminous matter. Its surface is finished similar to Type A.

Type E is composed of two layers of saturated felt cemented together and coated with bituminous matter, being finished on the surface similar to Type A.

Type F is composed of two layers of saturated felt, cemented together with a layer of burlap in between, and coated with bituminous matter. Its surface is finished as in Type A.

Where burlap is used, it is usually embedded in the bituminous cementing or coating material without previously being saturated, due to the fact that burlap, on account of its structure, does not absorb the bituminous saturation in the same manner as felt.

Physical Tests of the Finished Fabric. The finished material is tested for pliability, weight, thickness and tensile strength.

Pliability is tested by cutting lengthwise from the centre of the roll a strip

¹ "A New Device for the Mechanical Analysis of Concrete Aggregates," by C. N. Forrest, *Proc. Am. Soc. Testing Materials*, 6, 458, 1906.

² "Analysis and Testing of Prepared Roofings," *J. Ind. Eng. Chem.*, 9, 1048, 1917.

1 in. wide, and commencing with the largest, successively bending it around various cylinders under water at temperatures of 77 and 32° F., respectively, recording the cylinder on which the surface cracks. Five cylinders are used in the test, meas-

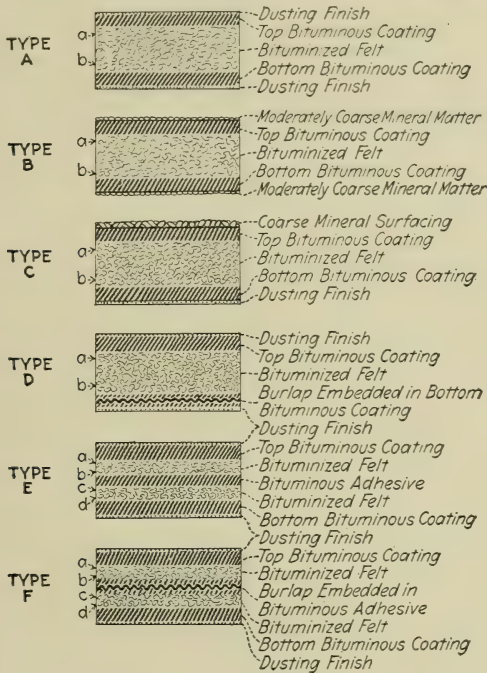

FIG. 199.—Types of Prepared Roofings.

uring 2½, 2, 1½, 1 and ½ cm. in diameter, respectively. A convenient apparatus for this purpose is shown in Fig. 200. The roofing should be bent parallel to itself, through an arc of 180°, at a uniform speed, and in exactly 2 seconds time.

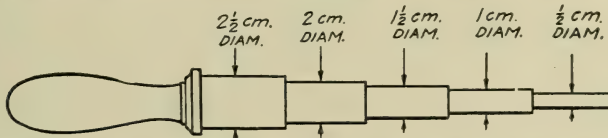

FIG. 200.—Mandrels for Testing the Pliability of Prepared Roofings.

The pliability is expressed in figures from 1 to 10, as follows:

- 1 May be bent through an arc of 180° in one direction (i.e., flat on itself), and then through an arc of 360° in the other direction (i.e., flat on itself) without cracking the surface coatings.
- 2 May be bent flat on itself (i.e., through an arc of 180°) without cracking the surface coatings, but will crack when bent through an arc of 360° in the other direction.
- 3 Surface cracks when bent through an arc of 180° (flat on itself).
- 4 Surface cracks on the ½-cm. cylinder.
- 5 Surface cracks on the 1-cm. cylinder.

- 6 Surface cracks on the $1\frac{1}{2}$ -cm. cylinder.
- 7 Surface cracks on the 2-cm. cylinder.
- 8 Surface cracks on the $2\frac{1}{2}$ -cm. cylinder.
- 9 Both the surface and the interior of the sheet crack on the $2\frac{1}{2}$ -cm. cylinder without, however, cracking *entirely* through the sheet.
- 10 The sheet cracks entirely through on the $2\frac{1}{2}$ -cm. cylinder.

Weight, in lbs. per 100 sq. ft., is determined in accordance with the method to be described later.

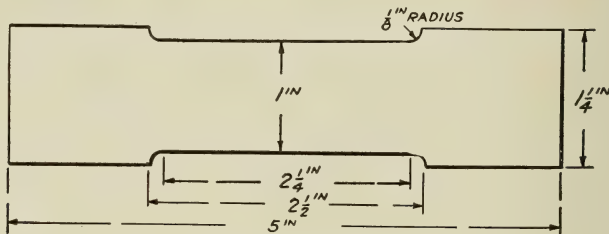

FIG. 201.—Tensile Strength Specimen.

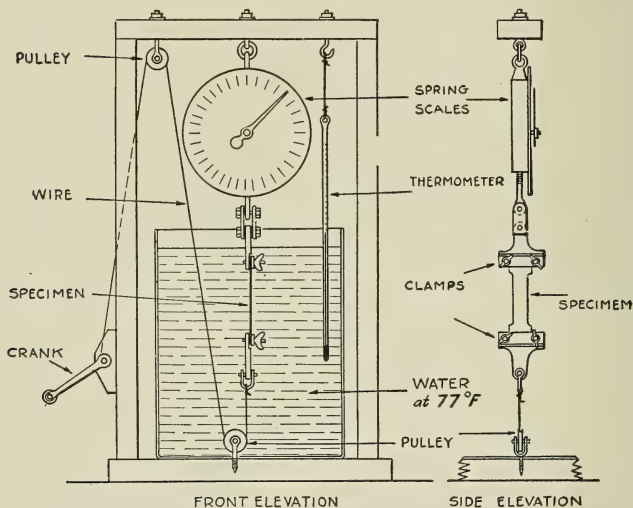

FIG. 202.—Instrument for Testing the Tensile Strength of Prepared Roofings.

Thickness, in mils (thousandths of an inch), is determined with a micrometer caliper, having flat bearing surfaces about $\frac{1}{2}$ in. in diameter.

Tensile Strength is determined by subjecting a specimen cut in the direction of the length of the roll and of the dimensions shown in Fig. 201 to a tension which is increased at a uniform speed of 3 lbs. per second, the specimen being maintained at a uniform temperature of 77° F. during the test. A simple and effective instrument for finding the tensile strength is shown in Fig. 202. Ten such tests are averaged.

The author has found that the following three tests will throw considerable light on the probable behavior of the bituminized fabric upon exposure to the elements.

(1) *Heating to 125° F. for 100 Hrs.*—A strip of the roofing is cut exactly 12 in. × 12 in., care being taken not to disturb any of the detached mineral matter on the surface, and suspended in an oven from a thin wire fastened through holes in the upper edge of the strip. The piece of roofing should be allowed to hang freely and maintained at a temperature of 125° F. for 100 hrs. At the end of this time the roofing is allowed to cool. The pliability, weight, thickness and strength are redetermined and the changes from the original figures expressed in percentages. Any change in the appearance of the surface should also be noted, e.g., sliding of the mineral matter, absorption of the coating by the felt, any yellowing of the surface blistering, etc.

Heating Test No. 1 shows the susceptibility of the roofing to the heat of the sun. The loss in weight is equivalent to the volatile matter; a decrease in thickness would indicate that the surface coatings have too low a fusing-point and are absorbed by the saturant; a large increase in tensile strength and decrease in pliability would indicate that the roofing has a tendency to dry out rapidly on exposure to the elements. Any yellowing of the mineral matter on the surface would indicate the presence of unstable oils in the bituminous coating or saturation.

(2) *Exposure to Air Saturated with Moisture at 77° F. for 100 Hrs.*—Accurately cut a strip of roofing 18 in. × 18 in., and weigh. Remove the detached mineral particles from both sides of the sheet with a moderately stiff brush, and reweigh (area equals 2½ sq. ft.). Suspend in a tight box containing sufficient water at the bottom to saturate the air with moisture. Cover tightly and allow the specimen to remain in the moist air for 100 hours at 77° F. As the moisture enters more readily through the cut edges of the sheet than through the surface itself, 6 in. should be trimmed from the edges at the termination of the test, leaving a strip measuring exactly 12 in. × 12 in., representing the central portion of the original specimen, and weighing $\frac{4}{9}$ of the latter. Ascertain the weight, thickness and tensile strength of the 12×12 portion at the end of the test, and calculate any variation in percentage from the original figures. The increase in weight should be figured on the basis of the original material *including* the detached mineral matter.

(3) *Immersion in Water at 77° F. for 100 Hrs.* This test is run exactly the same as the preceding, only in this case the specimen should be immersed entirely in water at 77° F. for 100 hours. An 18 in. × 18 in. sheet of roofing should be used in making the test, and trimmed to 12 in. × 12 in. before redetermining its weight, thickness or strength.

Tests Nos. 2 and 3 show the susceptibility of the roofing to the action of dampness and water.

A skeleton of the physical tests just described is shown in Table XXXVIII.

A variation of these tests consists in first subjecting a specimen of the roofing to the action of moist air or water for 100 hrs., then drying at 125° F. for 100 hrs., re-subjecting to the action of moist air or water for another 100 hrs., and finally repeating the drying process for 100 hrs.

Although these tests throw considerable light on the behavior of the roofing towards atmospheric heat and moisture, nevertheless they fail to record one very important factor, namely, the effect of atmospheric *oxidation*. At the present time we know of no accelerated test by which this can be accurately measured. The effect of oxidation can be recorded only by actually submitting the roofing to an exposure test for a lengthy period of time. (See p. 577.)

TABLE XXXVIII—PHYSICAL TESTING OF PREPARED ROOFINGS

	Original Material	After Heating to 125° F. for 100 hrs.	After Exposing to Air Saturated with Moisture at 77° F. for 100 hrs.	After Immersing in Water at 77° F. for 100 hrs.
Pliability at 77° F.	<i>P</i>	<i>P</i> ₁
Pliability at 32° F.	<i>p</i>	<i>p</i> ₁
Weight in lbs. per 100 sq.ft.	<i>w</i>	<i>w</i> ₁	<i>w</i> ₂	<i>w</i> ₃
% Decrease in Weight	$\frac{w-w_1}{w} \times 100$
% Increase in Weight	$\frac{w_2-w}{w} \times 100$	$\frac{w_3-w}{w} \times 100$
Thickness in Mils.	<i>t</i>	<i>t</i> ₁	<i>t</i> ₂	<i>t</i> ₃
% Decrease in Thickness	$\frac{t-t_1}{t} \times 100$
% Increase in Thickness	$\frac{t_2-t}{t} \times 100$	$\frac{t_3-t}{t} \times 100$
Tensile Strength at 77° F.	<i>s</i>	<i>s</i> ₁	<i>s</i> ₂	<i>s</i> ₃
% Decrease in Strength	$\frac{s-s_2}{s} \times 100$	$\frac{s-s_3}{s} \times 100$
% Increase in Strength	$\frac{s_1-s}{s} \times 100$

Separating Prepared Roofing into Its Component Parts. The mineral matter, bituminous matter and fibrous matter are distributed in the following manner:

MINERAL MATTER

- | | | |
|---|--|--|
| <p>1—Detached</p> <p>2—Embedded in the top surface coating</p> <p>3—Embedded in the bottom surface coating</p> <p>4—Admixed with the top surface coating (Types A, B, C, D, E and F)</p> <p>5—Admixed with the bottom surface coating (Types A, B, C, D, E and F)</p> <p>6—Admixed with the cementing layer (Types E and F)</p> | <p><i>Very Fine Mineral Matter</i> (e.g., finely ground talc, mica or silica) Types A, D, E and F (on top and bottom) also Type C (on bottom only).</p> <p><i>Moderately Coarse Mineral Matter</i> (e.g., sand, coarsely ground talc, and coarse mica flakes) Type B (on top and bottom).</p> <p><i>Coarse Mineral Matter</i> (e.g., crushed slate, crushed brick or tile, crushed feldspar or granite, small pebbles or gravel) Type C (on top only).</p> | <p>May or may not be present. If present, consists of very fine mineral matter (e.g., clay, silica, limestone, shale, colored mineral oxides, etc.).</p> |
|---|--|--|

BITUMINOUS MATTER

- 1—Contained in the top surface coating (all types).
- 2—Contained in the bottom surface coating (all types).
- 3—Contained in the cementing layer (Types D and F).
- 4—Contained in the felt, present in either one layer (Types A, B, C and D) or distributed in several layers (Types E and F).

FIBROUS MATTER

- 1—One or more layers of felt (all types).
- 2—Burlap or other fabric (Types E and F).

The separation of prepared roofing into its component parts is carried out as follows:

Weight Per 100 Sq. Ft. Carefully unpack the roll, taking care not to detach any of the mineral surfacing or dusting finish. Weigh the roofing after removing the wrapper, ends, nails and lap-cement packed in the core of the roll. Measure the length and breadth of the roll with a steel tape, recording the dimensions to $\frac{1}{16}$ in. Calculate the area in square feet.

Figure the weight of the finished roofing in lbs. per 100 sq. ft. (1)
Cut several strips *exactly* 3 in. wide *across* the sheet.

NOTE.—With roofing 36 in. wide, these strips will measure exactly $\frac{3}{4}$ sq. ft., and with roofing 32 in. wide, they will measure $\frac{2}{3}$ sq. ft. Find the weight of each strip in grams.

Calculate the weight of the roofing in lbs. per 100 sq. ft. (2)

NOTE.—With 36 in. roofing, wt. in lbs. per 100 sq. ft. = $0.294 \times \text{wt. 3 in. strip in grams}$.

With 32 in. roofing, wt. in lbs. per 100 sq. ft. = $0.331 \times \text{wt. 3 in. strip in grams}$.

CHECK—Result (1) should equal result (2).

Detached Mineral Matter. Remove the detached mineral particles from both sides of the 3-in. strips with a moderately stiff brush or cloth and reweigh in grams.

Calculate the weight detached mineral matter in lbs. per 100 sq. ft. (3)

Dry Felt and Burlap; Total Embedded and Admixed Mineral Matter; Total Bituminous Matter. Extract one of the 3-in. strips in a Soxhlet extractor with benzol. Dry the extracted fabric together with any adhering mineral matter at 110° C. Cool in a desiccator and weigh the felt as rapidly as possible before it has an opportunity to absorb moisture from the air. Repeat the drying, until the weight is constant. Carefully brush off, weigh and set aside the adhering mineral matter.

Calculate the weight of each layer dry felt or burlap in lbs. per 100 sq. ft. (4)

NOTE.—Use the separated felt or burlap for examining its physical and chemical characteristics according to the methods to be described later.

Separate the mineral matter from the benzol extract by filtering or centrifuging; wash clean with successive portions of benzol, dry and weigh. Combine with the mineral matter brushed off the extracted felt.

Calculate the weight of the total embedded and admixed mineral matter in lbs. per 100 sq. ft. . . . (5)

Screen through a set of standard sieves of different mesh. A mere inspection of the particles retained by the various screens will enable one to distinguish the moderately coarse or coarse embedded mineral matter from any very fine admixed mineral matter present in Types B and C.

Calculate the weight of moderately coarse or coarse embedded mineral matter in lbs. per 100 sq. ft.

for Types B and C; or calculate the combined weight of very fine embedded mineral matter and admixed mineral matter in lbs. per 100 sq. ft. for Types A, D, E and F. (6)

Calculate the total weight of bituminous matter in lbs. per 100 sq. ft., i.e., $[1] - [(3) + (4) + (5)]$. . . (7)

Bituminous Saturation in the Felt. Warm a strip about 2 in. wide cut lengthwise from the roll, and tear off the coatings as shown in Fig. 203, taking care that in so doing as little as possible of the saturated felt is removed with the coatings, and, on the other hand, that *none* of the coatings or cementing layer remain adhering to the strip of saturated felt. The small arrows to the left of the various types of roofing illustrated in Fig. 199 indicate approximately where the layers

should be separated. This can readily be accomplished with a little practice and dexterity. Where the roofing is composed of one layer of felt, as in Types A, B, C and D, the zone between the arrows *a* and *b* should be separated. Where the roofing is composed of two layers of felt, as in Types E and F, separate the zones between the arrows *a* and *b*, also *c* and *d*, respectively. In this manner, about 25 g. of the saturated felt (free from the coating or cementing layers) are obtained from each layer. Weigh and extract each portion separately in a Soxhlet with benzol. Dry the extracted felt at 110° C. to constant weight, desiccate and weigh. Calculate the weight of bituminous saturation by difference, and evaporate the benzol extract to exactly this weight.

NOTE—Use the residue of bituminous saturation recovered from each layer of felt for examining its physical and chemical characteristics, according to the methods described later.

Calculate the per cent of bituminous saturation carried by each layer of dry felt. (8)

Calculate the weight of bituminous saturation present in each layer of the felt in lbs. per 100 sq. ft. [i.e. (8) × (4)]. (9)

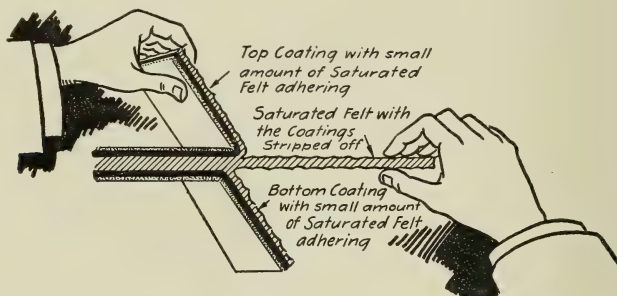

FIG. 203.—Method of Stripping the Coatings from the Saturated Felt.

Weights of Bituminous Matter in the Coatings and Cementing Layer.—In types A, B, C and D. The combined weights of bituminous matter in the top and bottom coatings in lbs. per 100 sq. ft. may be calculated by subtracting (9) from (7). To find the respective weights of bituminous matter in the top and bottom surface coatings, take a 3-in. strip cut across the sheet of roofing, from which the detached mineral matter has been removed, and split it lengthwise by tearing the felt midway between the points *a* and *b* (Fig. 199). Weigh and extract each section separately in a Soxhlet. Desiccate and weigh the dry felt in each section (and the burlap in Type D), also separate and weigh the total embedded and admixed mineral matter. Calculate the weight of bituminous saturation present [i.e., weight of dry felt × (8)]. From the original weight of each section subtract the combined weights of dry felt, bituminous saturation, embedded and admixed mineral matter. The difference represents the weight of bituminous matter in the surface coating carried by that particular section.

Calculate the weights of bituminous matter in the top and bottom coats, respectively, in lbs. per 100 sq. ft. (10)

In Types E and F. Take a 3-in. strip freed from the detached mineral matter as previously described, and split it into three sections, by tearing through the felt midway between the points *a* and *b*, also *c* and *d*, respectively (Fig. 199). Weigh and extract each of the three sections separately in a Soxhlet. Separate,

and in each case weigh the dry felt (also the burlap in Type F) and the total mineral matter. Following the method previously described:

- Calculate weights of bituminous matter in the top and bottom coats respectively in lbs. per 100 sq. ft. (11)
- Calculate weight of bituminous matter in the cementing layer in lbs. per 100 sq. ft.
- Calculate weight of very fine mineral matter admixed with the cementing layer in lbs. per 100 sq. ft.

Very Fine Embedded Mineral Matter also Admixed Mineral Matter, in the Top and Bottom Coatings Respectively. Types A, D, E and F. Take another 3-in. strip from which the detached mineral matter has been brushed off, and remove the outer layer of the top and bottom coatings respectively, by means of moderately rough sand paper. Enough of the surface should be scraped to remove every vestige of the very fine embedded mineral matter, and at the same time care should be taken *not* to cut completely through the surface coatings into the saturated felt underneath.

With Types A and D, split the scraped sheets lengthwise midway between the points *a* and *b*. With types E and F, split the scraped sheets lengthwise midway respectively, between the points *a* and *b*, also *c* and *d*, discarding the central section. Extract the scraped outer sections separately with benzol as before, recovering and weighing:

- The dry felt present in the respective scraped sections. (12)
- The admixed mineral matter present in the scraped sections. (13)
- The total bituminous matter present in the surface coating and saturating the felt in the respective scraped sections. (14)
- The dry burlap (in Type D).
- Calculate the bituminous matter present in the felt in the respective scraped sections [(8) ÷ 100 × (12)]. (15)
- Hence the bituminous matter present in the surface coating remaining on the respective scraped sections = (14) - (15). (16)
- The proportion of very fine mineral matter admixed with the bituminous matter in each coating = (13) ÷ (16). (17)
- Total weight of very fine mineral matter *admixed* with the respective coatings in lbs. per 100 sq. ft. = (17) × (10) [in Types A and D] or (17) × (11) [in Types E and F]. (18)
- And weight of very fine mineral matter *embedded* in the surface of the respective coatings in lbs. per 100 sq. ft. = (6) - (18).

Nature of the Bituminous Matter in the Coatings and Cementing Layer. Brush off the detached mineral matter from a surface about 2 sq. ft. in area. Then scrape

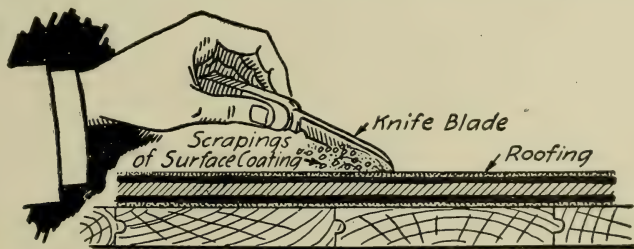

FIG. 204.—Method of Removing the Coatings.

off the outer portion of the surface coating with a sharp knife. This is accomplished by holding the knife at right angles to the sheet of roofing resting on a firm, level surface, and rapidly drawing the blade sideways under moderate pressure (Fig. 204). Care should be taken to avoid scraping entirely through the surface coating. This is

important. Weigh and then dissolve the scrapings in benzol. Separate the mineral matter by filtering or centrifuging, and wash with successive portions of benzol. Dry and weigh the mineral matter. Calculate the weight of bituminous matter in the scrapings by difference, and evaporate the combined benzol extracts on the water bath to exactly this weight, completing the evaporation if necessary in an oven. Both surface coatings should be treated separately in this manner. In Type D the bottom coating may readily be removed by cooling the specimen in an ice-chest and *rapidly* tearing off the burlap, which will carry most of the bottom coat with it. This should be extracted, filtered and the extract evaporated to obtain the pure bituminous matter present.

With Type F the central web of burlap may be torn out, and the bituminous matter contained in the cementing layer separated in the same manner.

With Type E the bituminous matter may be separated from the cementing layer between the sheets of felt, by cooling in an ice-chest, rapidly tearing the specimen in two along the plane of the cementing layer, scraping and separating the bituminous matter as described for the surface coatings.

Use the separated bituminous matter for examining its physical and chemical characteristics.

Testing the Raw Felt. Ash. The ash is determined by incineration and calculated in percentage.

Fibres Present. The percentage composition of the fibres is determined microscopically by staining them with a solution of zinc-chlor-iodide (prepared by dissolving 4 g. of potassium iodide and 0.1 g. of iodine in 12 c.c. of water, and then adding 20 g. of zinc chloride), and counting under a microscope having a magnification of about 100 diameters. The individual fibres are recognized by their characteristic shapes and the colors they are stained by the zinc-chlor-iodide solution. The percentages are ascertained by counting the fibres in a number of fields and finding their average. The following classes of fibres are reported:

Rag Fibres	{	Cotton fibres—stained wine-red
		Wool fibres—unstained by the solution
Paper Fibres	{	Jute and manila fibres—stained a yellowish brown
		Mechanical wood pulp—stained lemon-yellow
		Chemical wood pulp (sulphite and sulphate)—stained grayish purple to purple

The following solution has been suggested for distinguishing the different kinds of chemical wood pulp, including unbleached and bleached sulphite pulps.¹ The fibres are first moistened with a 5 per cent solution of ammonium molybdate and then with a solution of paranitroaniline (200 mg. dissolved in 80 c.c. of distilled water, to which are added 20 mg. sulphuric acid, sp.gr. 1.767). This stains the fibres as follows:

Mechanical wood pulp.....	bright reddish orange
Unbleached sulphite pulp.....	faint dull orange to faint brownish
Bleached sulphite pulp.....	colorless.

Another reagent recently proposed for this purpose² is prepared by mixing equal volumes of N/10 ferric chloride and N/10 potassium ferricyanide solutions. The moist fibres are immersed for 15 minutes at a temperature of 35° C., removed and washed thoroughly with water. They are then immersed in a freshly prepared

¹ "Paper Reagent," by W. J. Schepp, *Chemist Analyst*, p. 20, September, 1917.

² "A Method to Distinguish between Bleached and Unbleached Sulphite Pulps," by C. G. Bright, *J. Ind. Eng. Chem.*, 9, 1044, 1917.

red stain composed of: benzopurpurin 4-B extra (Bayer & Co.) 0.4 g.; oxamine brilliant red BX (Badische Co.) 0.1 g.; and distilled water 100 c.c. This is maintained at 45° C. for 5-6 minutes, the fibres thereupon removed, washed immediately with water, and examined under a microscope. Unbleached sulphite pulp, ground wood, jute, or any lignified fibres are stained a deep blue (the depth depending upon the lignin content); whereas bleached sulphite pulp, soda pulp, rags, wool or any thoroughly bleached fibres are stained a brilliant red.

"Number." This is an arbitrary figure adopted by the trade, corresponding to the weight in pounds of a ream consisting of 480 sheets, each measuring 12 in. × 12 in.

Thickness. This is expressed in mils.

Mullen Strength. Since the raw felt is not susceptible to changes in temperature (as is the case with the finished roofing) it may be tested for tensile strength by means of the Mullen tester.¹ The specimen is accordingly tested at room temperature by increasing the tension at a *uniform* speed of 2 lbs. per second until it ruptures.

Thickness Factor. This is equal to the thickness in mils divided by the "number" of the felt.

Strength Factor. This is equal to the Mullen strength in pounds divided by the "number" of the felt.

Testing the Raw Burlap or Duck. *Weight.* In the case of burlap and cotton duck, the weight is figured as explained on p. 390.

Thickness. Expressed in mils.

Mullen Strength. Determined as described for testing the raw felt.

Bituminous Coating, Saturation and Cementing Compounds. These should be examined by the methods described in Chapters XXIX to XXXI inclusive.

Mineral Surfacing and Admixed Mineral Matter. These may be examined by the methods outlined in Test 36 (p. 538).

BITUMINOUS EMULSIONS

These include bituminous emulsifying oils used for laying dust ("dust palliatives" p. 353), also bituminous emulsions used for waterproofing Portland-cement mortar and concrete (p. 457). The following products are likely to be present, viz.: water, ammonia, various chemicals, bituminous matter, animal and vegetable oils or fats, other forms of non-bituminous organic matter and mineral matter.

Water is determined as described for Test 25. Ammonia is liberated by rendering alkali with caustic potash and heating. If present, it is detected by its odor, and may be determined quantitatively by distilling into a standard solution of sul-

¹The tensile strength of the dry felt is increased materially by extracting with solvents, but it may be made to correspond closely with its original figures, by exposing the desaturated felt for 3 days to air at 77° F. completely saturated with moisture, prior to its being tested. The following figures will illustrate this point, viz.: strength original felt (before extraction), 23.3 lb. (average of 10 tests); original felt upon heating to 265° F. for 5 minutes, cooling in a desiccator and testing immediately, 26.9 lb.; original felt upon extracting with benzol in Soxhlet for 5 hours, cooling in desiccator and testing immediately, 36.4 lb.; extracted felt exposed 3 days to air at 77° F. carrying 30 per cent moisture, 33.6 lb.; extracted felt exposed 3 days to air at 77° F. completely saturated with moisture, 27.6 lb.

phuric acid and retitrating with alkali. The presence of chemicals may be detected by boiling with water, acidifying with hydrochloric acid and extracting the bituminous and fatty substances with benzol. The chemicals remain in the aqueous layer and may be determined by a qualitative or quantitative analysis. Bituminous matter is determined by saponifying the material and then extracting the unsaponifiable constituents as described in Test 39a. The non-bituminous organic matter and the chemicals are separated from the bituminous and fatty matters as previously described, and the non-bituminous organic matter in turn separated from the chemicals by suitable methods. Mineral matter is determined by incinerating a weighed quantity of the material and examining the ash as described in Test 36. Animal and vegetable oils or fats are examined by Tests 37, 39 and 40 respectively.

BITUMINOUS PAINTS, CEMENTS, VARNISHES AND JAPANS

As pointed out in Chapter XXVII, bituminous paints, cements, varnishes, enamels and japans are all characterized by the presence of a volatile solvent with a bituminous base, combined in the form of "vehicle." Depending upon whether or not the bituminous paints and cements contain a pigment or filler, they may be divided into two general classes, viz.:

- (1) Pigment or filler absent: including bituminous varnishes and japans, also certain bituminous paints and cements.
- (2) Pigment or filler present: including bituminous enamels, also certain bituminous paints and cements.

The first class consists of a vehicle made up of a solvent and base. The second consists of a pigment or filler combined with a vehicle, the latter similarly being made up of a solvent and base. The bituminous base may be composed of bituminous matter, with or without the presence of animal and vegetable oils or fats, resins or metallic dryers. In making an analysis of the paint, cement, varnish, enamel or japan, the following components are separated and examined viz.: (1) solvent, (2) pigment or filler, (3) base.

Estimation of Solvent. *Rapid method used for determining the percentage of solvent present:*

The method devised by A. L. Brown is rapid and gives accurate results, but does not recover the solvent for further examination.¹ Deliver 3-4 c.c. of the well-mixed material (cements as well as paints of a heavy body should first be thinned to fluid consistency with a weighed quantity of pure benzol) from a 10-c.c. pipette into a weighed glass flask of 50 c.c. capacity, as rapidly as possible. Stopper the flask immediately, weigh, and dilute to the mark with pure benzol. Deliver exactly 10 c.c. of the well-mixed material from the pipette upon a weighed ground-glass plate, 10 by 15 cm. and 1.5-3.0 mm. thick, supported in a level position.

¹ "Quantitative Determination of Body and Solvent in Varnish," by A. L. Brown, *Proc. Am. Soc. Testing Materials*, 14, Part II, 467, 1914; "Determination of Volatile Thinner in Oil Varnish," by E. W. Boughton, Technologic Paper No. 76, Bureau of Standards, Wash., D. C., June 21, 1916.

The diluted material should be flowed gradually on the plate, the object being to cover it entirely, without causing the solution to creep over the edges. It is recommended that 7 c.c. be delivered first, and the remainder, a few drops at a time during the ensuing 2 minutes. The evaporation of the benzol will carry most of the solvent with it, and the film is so thin that the solvent will evaporate in $1\frac{1}{2}$ - $2\frac{1}{2}$ hours, the plate being weighed every half hour to follow the course of evaporation. Should the material contain a drying oil, the plate must be placed in an atmosphere of illuminating gas after the first half hour, replacing it after each weighing. The solvent has entirely evaporated when a constant weight is obtained. From this calculate the percentage of solvent by weight. An idea of the drying qualities of the film may be gained by placing the glass in a free circulation of air after the solvent is eliminated, and weighing it every hour as the film oxidizes, until it no longer *increases* in weight. If the coating has a tendency to dry unevenly, a weighed quantity of 50-mesh sea sand, previously dried and ignited, may be sifted over the paint in a very thin layer, but so the paint will be visible between the grains of sand. This will insure a uniform evaporation of the solvent.

Method Used for Recovering the Solvent for Its Examination and Identification. Distil 100 g. paint in a 500-c.c. flask, connected with a spray-trap and a vertical condenser, and pass through it a current of dry steam, the flask being heated in an oil bath to 100° C. As the steam passes through, gradually raise the temperature of the bath to 130° C. Catch the distillate in a separatory funnel, continuing the distillation until the funnel contains 400 c.c. of water. To prevent frothing and bumping, it is advantageous to weigh a small piece of broken glass or pumice-stone into the flask. Let the distillate stand until it separates into two layers, then draw off the water and determine the volume and weight of solvent recovered. Weigh out another 100 g. into a 250-c.c. flask and distil without steam over an electric stove. Continue the distillation until the residue in the flask reaches a temperature of 200° C. This gives somewhat lower results than the first method, but the distillate should be tested for water soluble substances to correct the results obtained by the previous method. Turpentine dissolves to the extent of 0.3 g. for each 100 c.c. of water condensed.¹

Pigment and Filler. Dilute 100 g. of the well-mixed material with 500 c.c. of benzol in an 800-c.c. stoppered flask. Let stand in a warm place until the pigment or filler has settled, then carefully decant the supernatant liquid into a clean flask of large capacity. The pigment or filler is shaken up with 250 c.c. more benzol, allowed to stand in a warm place until it settles, and the supernatant liquid decanted into the second flask. Repeat the treatment with benzol until the vehicle has been completely extracted from the pigment. The combined extracts are allowed to stand quietly to recover any pigment that may have been carried over with the benzol, and then carefully decanted through a weighed Gooch crucible provided with an asbestos filter. The residues in the flask and on the Gooch crucible are washed with benzol as before, and combined with the balance of pigment or filler which is then dried at 110° C. and weighed. The pigment or filler thus extracted is used for a qualitative or quantitative analysis (Test 36c).²

Examination of the Base. The combined extracts of the preceding test are distilled to a small bulk, transferred to a tared dish, and evaporated in an oven at

¹ "Some Technical Methods of Testing Miscellaneous Supplies," by P. H. Walker, Bulletin No. 109, Revised, Bureau of Chem., U. S. Dept. of Agri., Wash., D. C., Feb. 28, 1910.

² "Analysis of Paints and Painting Materials," by H. A. Gardner and J. A. Schaeffer, N. Y., 1911.

110° C. *exactly* to the calculated weight of the base, by subtracting the weights of solvent and pigment or filler from the original weight of material taken for examination. When oxidizable substances are present, the final evaporation should take place in an atmosphere of illuminating gas.

The base recovered in this manner will contain the bituminous material (with the exception of the "free carbon" which will be separated with the pigments), animal and vegetable oils or fats, resins and metallic bases and dryers. It should be tested by the methods described in Chapters XXVIII and XXIX, to identify the materials used in its manufacture, or to aid in its duplication. It may be separated into its component parts as follows:

Method of Analyzing the Separated Base

Dissolve 50 g. in 150 c.c. benzol. Add 10 c.c. dil. nitric acid (1 : 1) and boil under a reflux condenser for ½ hour to decompose any metallic bases (i.e. driers, etc.). Add 150 c.c. water, boil under reflux condenser, transfer to a separatory funnel, draw off the aqueous layer, boil with another 100 c.c. water, and repeat if necessary until all the metals are removed.

Benzol Solution:

Distil to 100 c.c., add 300 c.c. of the saponifying liquid (Test 39), boil under reflux condenser for 1 hour, and separate the unsaponifiable and saponifiable constituents as described in Test 39.

Aqueous Extract:

Contains the metallic bases as nitrates. Examine qualitatively and then quantitatively for lead, manganese, cobalt, zinc, calcium, and magnesium.

Unsaponifiable Matter:

Examine a small portion by Test 43. If higher alcohols are present, separate the balance by Test 39. into:

Saponifiable Matter:

Separate the fatty and resin acids as described in Test 37e.

Aqueous Layer:

Determine percentage glycerol by Test 40. Multiply this by 10 to estimate percent of vegetable or animal oils or fats (triglycerides) present in the original substance. (Note "C").

Hydrocarbons:

Contain the bituminous substances (i.e. asphalt coal-tar pitch unsp. matter derived from fatty-acid pitch, etc.).

Examine by the methods included in Chaps. XXVIII to XXXI inclusive.

Higher Alcohols

Etc.:
Contain cholesterol etc. derived from wool grease, also the unsaponifiable constituents originally present in resins (4 to 8%).

Fatty Acids:

Include acids derived from vegetable and animal oils or fats, also from fatty-acid pitch. (Note "A").

Resin Acids:

Include acids derived from rosin and the fossil resins. (Note "B").

(N.B.—The last three used for hardening rosin. The metallic dryers should *not* be found by ignition, since the lead will be reduced to metal by the organic matter, and volatilized.)

Note "A"

The following means are used to distinguish between the fatty acids derived from oxidized vegetable or animal oils and fatty-acid pitch respectively:

	<i>Fatty Acids Derived From Vegetable or Animal Oils.</i>	<i>Fatty Acids Derived From Fatty-acid Pitch.</i>
Lactone Value (Test 37b)	Less than 25	Greater than 25
K. and S. Fusing-point (Test 15a)	Less than 80° F.	Greater than 80° F.
Hardness at 77° F. (Test 9c)	Less than 5.0	Greater than 5.0
Color in Mass (Test 1)	Translucent yellow to brown ..	Opaque brown to black

(Note "B")

Test qualitatively for rosin by the Liebermann-Storch reaction (Test 43). Fossil resins may be distinguished from rosin by determining the saponification, acid and ester values of the mixed resin acids. The following figures have been reported on the resin acids separated as described: ¹

¹ "The Determination of Rosin in Varnishes," by A. H. Gill, *J. Am. Chem. Soc.*, **28**, 1723, 1906; "Shellac Analysis," by E. F. Hicks, 8th Intern. Cong. of Applied Chem., **12**, 115, 1912.

	Saponification Value.	Acid Value.	Ester Value.
Straight Rosin Varnish.....	182-185	160-162	22-24
Rosin $\frac{1}{2}$; Kauri $\frac{1}{2}$ Varnish.....	122-135	44-62	72-78
Rosin $\frac{1}{3}$; Kauri $\frac{2}{3}$ Varnish.....	143.5	88	55.5
Straight Kauri Varnish.....	130	45	85
Untreated Rosin.....	165-180	155-170	0-13
Untreated Kauri Gum.....	124	41	83

Other resins may be examined in a like manner, although unfortunately, figures are not at present available.

Note "C"

If this corresponds with the total saponifiable matter present (Test 39), then fatty-acid pitch and resins are absent.¹

The following is an outline of a method devised by the author for examining the dry films of paints, cements, varnishes, enamels, or japans which have been applied to surfaces of metal wood, masonry, or prepared roofing. It often happens that none of the original material is available, and it becomes necessary to examine the paint after it has been applied to the object intended, and allowed to harden or oxidize in the air, either at normal or elevated temperatures. The method has been found to yield fairly accurate results.

Carefully scrape 50.00 g. of the paint or varnish film from the surface to which it has been applied, and avoid including any of the underlying surface.² From this point on the method is outlined in the following table:

Method of Analyzing Dried Paint Films

Boil 50 g. scrapings with 350 c.c. of the saponifying liquid (Test 39) under a reflux condenser for 1 hour. Add 300 c.c. benzol-alcohol (1 : 1), boil, let settle and decant the supernatant liquid into a large flask. Repeat the treatment with benzol-alcohol (1 : 1) until most of the soluble constituents have been extracted, then combine the extracts and let stand quietly to recover any further settlings, which after decantation and washing are added to the main portion of the residue.

Benzol-Alcohol (1 : 1)	<i>Residue:</i>	
<i>Extracts:</i>	Dry in an oven at 100° C., pulverize finely, transfer to a paper thimble and extract in a Soxhlet with benzol-alcohol (2 : 1) for 12 hours.	
	Benzol-Alcohol (2 : 1) Extract:	<i>Residue:</i>
Combine the benzol-alcohol (2 : 1) and (1 : 1) extracts, evaporated to a small bulk, and separate the unsaponifiable and saponifiable constituents as described in Test 39.		Dry, ignite and weigh. This includes pigments and fillers, free carbon from tars or pitches, also any metallic dryers present (Note "A").
Unsaponifiable Matter: Examine as described p. 572.	Saponifiable Matter: Examine as described p. 572.	Aqueous Layer: Examine as described p. 572.

Note "A"

This should be examined microscopically (Test 36d) for fillers, and subjected to a qualitative or quantitative chemical analysis. Note that any chrome green, chrome yellow, Prussian blue, etc., are transposed by the alkali, and these, also lampblack or carbon blacks are decomposed on ignition, for which due allowance must be made.

¹"Determination of Oil and Resin in Varnish," by E. W. Boughton, Technologic Paper No. C5, Bureau of Standards, Wash., D. C., Feb. 19, 1916.

²The blade of a safety razor held at right-angles to the surface scraped, and drawn across it slowly but firmly has been found convenient for this purpose.

CHAPTER XXXIII

WEATHERING TESTS

Effects of Weathering. All substances undergo a change on being exposed to air, moisture and sunlight. Metals undergo corrosion, rocks disintegrate, wood decays and animal or vegetable fibres decompose by hydrolysis. Bituminous substances are not immune from such action. On exposure to the weather (i.e., air, sunlight and moisture) they will change physically and chemically.

In the early days of photography, solutions of asphalt in etherial oils such as turpentine, oil of lavender, etc., were used for preparing the sensitized photographic film. On exposure to light under the lens of a camera, certain changes took place in the asphaltic coating, as evidenced by the fact that upon subjecting it to the action of turpentine, those portions which had been in contact with light became insoluble, but those protected from its action readily dissolved in the solvent, bringing the photographic image into relief. It took rather a long exposure to produce satisfactory images, since asphalt is only moderately sensitive to light in comparison with some of the high-speed photographic plates in use at the present time. Nevertheless very artistic results have been produced by this crude method. It was soon observed that certain forms of asphalt were more sensitive than other, and Syrian asphalt in particular (p. 135) became very popular on account of its purity, solubility, hardness and sensitiveness to the light's rays.¹ It was subsequently found that the addition of sulphur chloride increased the sensitiveness of native asphalts,² but petroleum asphalts were apparently rendered inert in its presence. Further investigations revealed the fact that petroleum asphalts free from paraffine are relatively the most sensitive towards light.³

Maximilian Toch noted that bituminous materials on exposure to sunlight decomposed with the liberation of "free carbon."⁴ His experi-

¹ "Syrian Asphaltum for Printing Plates," C. Fleck, *J. Soc. Chem. Ind.*, **23**, 268, 1904.

² "Increase of Sensitiveness of Asphalt," E. Valenta, *Phot. Korr.*, **47**, 236, 1910; "Sensitiveness of Asphalt to Light," by A. Rosinger, *Chem. Ztg.*, **36**, 243, 1913; "Chemistry of Asphalt and Especially Photo-chemical Properties," by Paul Gödrich, *Monatsh.*, **36**, 535, 1915.

³ "The Light-Sensitiveness of Petroleum Asphalt," by Paul Gödrich, *Chem. Ztg.*, **39**, 832, 1915.

⁴ "The Influence of Sunlight on Paints and Varnishes," by Maximilian Toch, *J. Soc. Chem. Ind.*, **27**, 311, 1908.

ments indicated that this action was inhibited by incorporating an opaque pigment. He pointed out further that animal and vegetable oils (triglycerides) are not affected in this manner, and when blended with bituminous materials, apparently retard the action.

Investigations of the weathering of bituminous substances have been conducted by Hubbard and Reeve,¹ Church and Weiss,² Reeve and Anderton³ and Reeve and Lewis.⁴ The changes brought about upon exposure to the elements are quite complicated, involving one or more of the following reactions:

Evaporation. This represents the gradual loss of volatile constituents on exposure to air and the sun's heat. Certain bituminous materials evaporate quite rapidly, and especially the tars. With any bituminous substance the rate of evaporation depends almost entirely upon the temperature. Other things being equal, the higher the temperature the greater the volatilization. The determination of volatile matter (Test 6) is usually regarded to be an accelerated evaporation test, which is supposed to show in a relatively short time at an elevated temperature, what takes place over a lengthy period when exposed naturally to the air and sun. This is not, however, strictly correct, as will be explained below.

Oxidation. This takes place on exposure to air and progresses more rapidly at high than at low temperatures. The effect of oxidation is twofold, and involves the direct union of oxygen with the bituminous substances, also the elimination of a portion of the hydrogen in the form of water. These two reactions may be expressed roughly as follows:

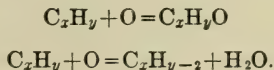

The absorption of oxygen is accompanied by a *gain* in weight whereas the elimination of hydrogen is accompanied by a *loss* in weight. At low temperatures, these reactions are probably induced to a large extent by the actinic light rays.

It is recognized that bituminous substances behave differently when heated in an inert atmosphere such as illuminating gas or nitrogen, than when heated under similar conditions in air or oxygen. In the former instance evaporation only takes place, whereas in the latter, evaporation occurs as before, but this at the same time is accompanied by a loss in weight due to elimination of hydrogen, also by a gain in weight caused by the absorption of oxygen. The extent and nature of these reactions will depend upon the substance itself, and also on the conditions to which it is subjected.

Carbonization. This represents the formation of "free carbon" in the bituminous material, and is induced by an extensive elimination of hydrogen as indicated by the following reaction:

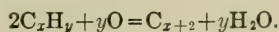

¹"The Effect of Exposure on Bitumens," by Prévost Hubbard and C. S. Reeve, *J. Ind. Eng. Chem.*, **5**, 15, 1913.

²"Some Experiments on Technical Bitumens," *Proc. Am. Soc. Testing Materials*, **15**, 275, 1915.

³"The Effects of Exposure on Tar Products," by C. S. Reeve and B. A. Anderton, *J. Franklin Inst.*, 463, Oct. 1916.

⁴"The Effects of Exposure on Some Fluid Bitumens," by C. S. Reeve and R. H. Lewis, *J. Ind. Chem.*, **9**, 743, 1917.

In other words, it represents the elimination of hydrogen carried to an extreme. As a matter of fact, the deposit of free carbon generally contains a small percentage of hydrogen, and is rarely composed of pure carbon. (See Hubbard, loc. cit.). This reaction progresses most rapidly in sunlight (p. 574) but will similarly take place upon subjecting the bituminous substance to a high temperature (see "Overheating," p. 549).

Polymerization. This is due to a condensation or polymerization of the molecules, and manifests itself by a hardening or "setting" of the substance.¹ This polymerization has also been termed "spontaneous hardening" and is comparable, in a way, to the hardening or setting of Portland cement. The reaction may be expressed as follows:

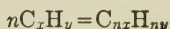

Bituminous materials after being freshly melted will appear softer and show a lower fusing-point than upon standing a day or two. For this reason it is recommended that the hardness and fusing-point be determined on the freshly melted material. Polymerization also takes place to a greater or lesser extent on heating bituminous materials to a high temperature, and is especially noticeable in fatty-acid pitches, some of which set and become infusible in the same manner as china-wood oil upon being heated in the neighborhood of 300° C.

Effects of Moisture. All bituminous substances are more or less affected upon exposure to moisture, which manifests itself in two ways, namely by the actual absorption of water and by the gradual leaching out of soluble constituents. These actions become intensified when the substance has oxidized, since oxygenated substances seem to have a greater affinity for moisture than the hydrocarbons themselves.

The moisture-absorbing properties of bituminous substances may be demonstrated optically by pasting a postage stamp on a piece of glass and coating it with a film of the bituminous substance applied in the form of paint. After the solvent has evaporated, the sheet of glass is immersed in water. Within 24 to 48 hours the water will be observed to have permeated the paint film, loosening the postage stamp, and forming a blister underneath.

Exposure to the weather affects the physical and chemical characteristics of bituminous substances in the following manner, viz.:

(Test 1)	Color in mass	Becomes lighter;
(Test 2)	Homogeneity	Destroyed by the formation of free carbon;
(Test 5)	Lustre	Disappears, the surface becoming dull;
(Test 6)	Streak	Often changes from a black to a brown, and sometimes to a yellow;
(Test 7)	Sp. gr. at 77° F.	Increases;
(Test 8)	Viscosity	Increases;
(Test 9)	Hardness or consistency	Increases;
(Test 10)	Ductility	Decreases;
(Test 11)	Tensile strength	Decreases;
(Test 12)	Adhesiveness	Decreases;
(Test 15)	Fusing-point	Increases;
(Test 16)	Volatile matter	Decreases;
(Test 17)	Flash-point	Increases;
(Test 18)	Burning-point	Increases;
(Test 19)	Fixed carbon	Increases;

¹"The Testing of Bitumens for Paving Purposes," by A. W. Dow, *Proc. Am. Soc. Testing Materials*, 3, 359, 1903.

- (Test 21a) Solubility in carbon disulphide. Decreases;
- (Test 21b) Non-mineral matter insoluble. Increases;
- (Test 22) Carbenes. Variable;
- (Test 23) Solubility in 88° petroleum naphtha. Decreases;
- (Test 31) Free carbon. Increases;
- (Test 37) Saponifiable constituents. Unchanged;
- (Test 39) Unsaponifiable matter. Unchanged;
- (Test 40) Glycerol. Unchanged.

The weather-resisting properties of bituminous substances are of primary importance in the case of bituminized roof coverings, bituminous paints, cements, varnishes and enamels, on account of the relatively *thin* layers in which these products are customarily employed.

NUMBER.....		DATE EXPOSED.....	
Name		Ply	Manufacturer
Cump'n Coat'g			
Cump'n Sat'n			
Date Manufactured		Received	
Observations When Exp'd	Predom Color		Remarks
	Fixed S'pst'n - Amount		Char.
	Top Coating - Amount		Char.
	Size	Thickness	Weight
	Pliability at 25C 		Tens. Streng.

Date Examined	A			D		E	F	G			H			Remarks
	B	C	a	b	a			b	a	b	c			

FIG. 205.—Exposure Test Card.

Conducting Weathering Tests on Bituminized Fabrics. The following system has been adopted by the author for conducting exposure tests on bituminized roof coverings, viz.:

Sections 18 in. by 36 in., or 18 in. by 32 in. depending upon whether the roofing is 36 or 32 in. wide, are taken across the sheet, the cutting being sharp and square. These are exposed on a platform, composed of $\frac{7}{8}$ in. tongued and grooved boards, preferably pine, having a 2 in. slope to the south, the samples being nailed with large-headed galvanized barbed roofing nails at the four corners, midway across the 18 in. edges, and at three intermediate points along the 36 or 32 in. edges, a total of 12 nails being used. A convenient card for recording data both initially and after exposure is illustrated in Fig. 205.

The predominating color is expressed numerically as follows: 1—white, 2—fairly white, 3—somewhat yellowish, 4—yellow, 5—light gray, 6—dark gray, 7—black, 8—becoming lighter, 9—becoming darker, 10—glossy, 11—dull, 12—iridescent.

The amount of soapstone is also recorded in digits, as follows: 1—much, 2—considerable, 3—little, 4—very little, 5—none.

The character of the soapstone is recorded by: 1—coarse, 2—granular, 3—medium, 4—fine.

The amount of the top coating by: 1—much, 2—considerable, 3—little, 4—very little, 5—none.

The character of the top coating: 1—coarse veining, 2—moderate veining, 3—fine veining, 4—very veined, 5—smooth.

The dimensions are recorded in inches measured lengthwise and across the specimen, the thickness in mils, the weight in grams, the pliability expressed as on p. 561, and the tensile strength as on p. 562.

Both the indoor and exposed samples are examined at the following intervals, viz.: $\frac{1}{2}$ year, 1, 2, 3, 4, 5 and 10 years, and the data recorded on the reverse side of the card, in columns A to H inclusive. The condition of the surface is expressed in digits as follows:

- (A) the amount of fixed soapstone remaining, expressed as 1—much, 2—considerable, 3—little, 4—very little, 5—none.
- (B) the amount of weather-coating remaining, expressed as 1—intact, 2—considerable, 3—little, 4—very little and 5—none.
- (C) the condition of the exposed surface, expressed as 1—unchanged, 2—homogeneous, 3—mottled, 4—smooth, 5—rough, 6—few fine checks, 7—covered with fine checks, 8—few coarse checks, 9—covered with coarse checks, 10—checks disappearing, 11—few blisters, 12—covered with blisters, 13—pitted, 14—few hair cracks, 15—covered with hair cracks, 16—covered with coarse cracks, 17—felt exposed in spots, 18—felt largely exposed.
- (Da) the predominating color of the indoor sample, and
- (Db) the predominating color of the exposed sample expressed as noted previously.
- (E) the amount of "dusting" determined by rubbing the surface with a white cloth and observing the amount of weathered bituminous coating removed, designated as 1—none, 2—very little, 3—little, 4—considerable, 5—very much.
- (F) the influence of rubbing on the color, designated as 1—none, 2—becomes dull, 3—becomes rusty, 4—becomes lighter, 5—becomes darker, 6—becomes glossy.
- (Ga) the pliability of the indoor sample at 77° F. (see p. 561), and
- (Gb) the pliability of the exposed sample at 77° F.
- (Ha) the tensile strength of the indoor sample at 77° F., and
- (Hb) the tensile strength of the exposed sample at 77° F., and
- (Hc) the percentage increase or decrease in the tensile strength of the exposed sample over that of the indoor sample.

The 8 specimens illustrated in Fig. 206 represent typical surface conditions as recorded in column C. The appearance of specimen A may be expressed as 1-2 (unchanged and homogeneous); that of specimen B as 7 (covered with fine checks); specimen C as 9 (covered with coarse checks); specimen D as 10 (checks disappearing, meaning that they existed when the previous observation was made, but have since largely disappeared); that of specimen E as 11 (showing a few blisters); that of specimen F as 15 (covered with hair cracks); that of specimen G as 16 (covered with coarse cracks); specimen H as 18 (felt largely exposed). These photographs were taken after the specimens were exposed to the weather for five years. Fig. 207 shows specimens A and H enlarged $3\frac{1}{2}$ diameters. The veined surface of A shows up very distinctly, and also the characteristic uneven appearance of the roofing when the weather-coating has worn off and the felt fibres exposed, as in H.

"Checking" is distinctly a surface phenomenon which manifests itself with certain substances on exposure. The checks rarely extend entirely through the bituminous coating, and are seemingly caused by the hardening and contraction of the upper stratum, resulting in a tension which is sufficient to cause it to crack

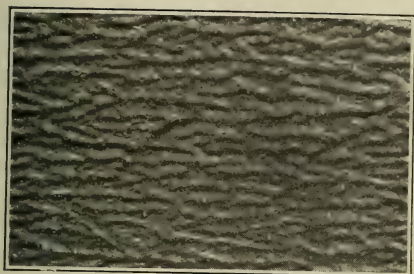

(A)

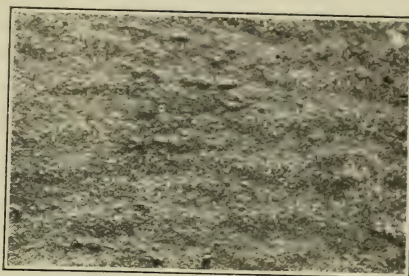

(E)

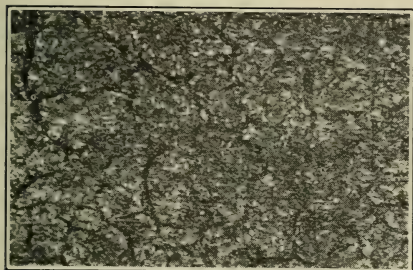

(B)

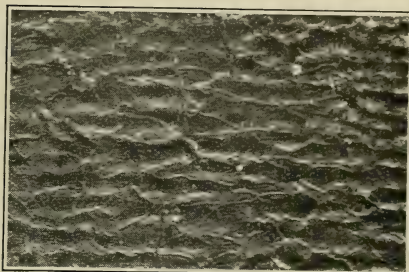

(F)

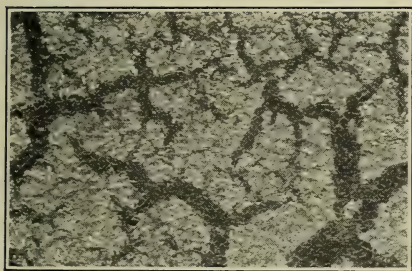

(C)

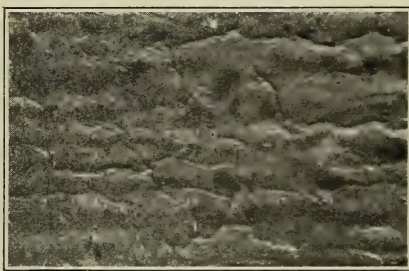

(G)

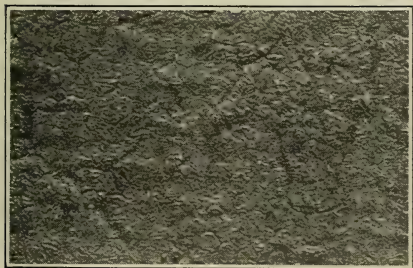

(D)



(H)

FIG. 206.—Effects of Exposure on Smooth-surfaced Prepared Roofings.

and slide over the softer sub-stratum. Bituminous substances which are largely influenced by changes in temperature (in other words having a high susceptibility factor) are likely to check. As the "spontaneous hardening" (p. 576) progresses downward into the lower layers, the checks gradually disappear.

Blistering is caused either by the accidental inclusion of globules of moisture underneath the bituminous coating, or by using a saturating material carrying an abnormally large proportion of volatile constituents. The heat of the sun will cause these to gradually vaporize, and the pressure exerted on the weather coating forms blisters.

Hair cracks are caused by the contraction of the bituminous material, and take place with substances which are hard, brittle, and devoid of elastic properties. The

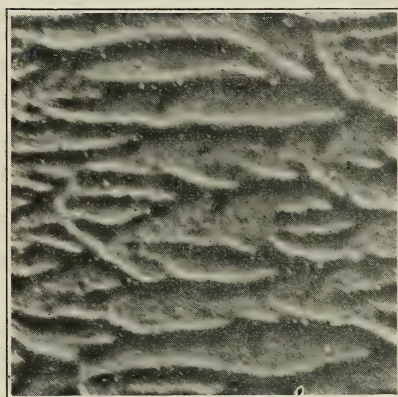

(A)

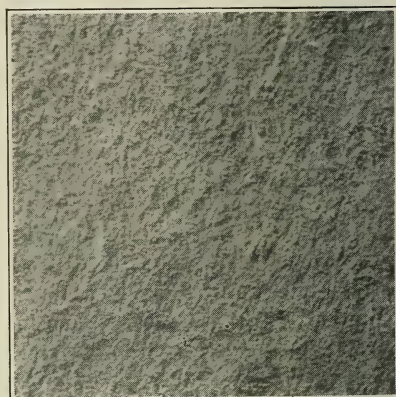

(H)

FIG. 207.—Enlargements of Specimens A and H in Fig. 206.

action is aggravated by the use of soft plastic saturating materials in conjunction with a hard and brittle coating. The cracks usually extend all the way through the bituminous coating, and will neither seal up nor disappear in time, as is the case with the checks.

The predominating color is a criterion of the rapidity with which the soapstone or mineral matter on the surface disappears, and the "dusting" furnishes an indication of the rate with which the bituminous coating weathers away on exposure. As bituminous substances weather, they form a pulverulent chalk-like mass having but little coherence, and which is therefore easily removed by wiping with a cloth. This corresponds to "chalking" of linseed-oil paint films. The influence of rubbing on the color is of supplemental value, furnishing an indication of how deep the weathering has progressed.

The pliability of the roofing shows to what extent the roofing has "dried out," bearing in mind that when the pliability decreases to a certain extent, the sheet can no longer fulfil its function properly, but will break upon being subjected to a severe vibratory strain.

The tensile strength indicates the extent to which the weathering has weakened the roofing, also an approximation of its residual wearing qualities. By constructing a curve of the tensile strength of the sheet at different intervals, some idea may be

gained of its probable durability. As the roofing ages indoors, it gradually gains in strength, until it finally remains constant. A similar sheet exposed out doors, rapidly gains in strength up to a certain point, which corresponds to the disappearance of its weather coating. The tensile strength will thereupon decrease until it falls below the corresponding strength of the indoor sample. The roofing reaches its "mean effective life" when the strength curve of the outdoor sample crosses the curve of the indoor sample. This will be made clear by Fig. 208 showing the strength curves of representative high-grade 1, 2 and 3 ply smooth-surfaced prepared roofings weighing 32, 42 and 52 lb. net per 108 sq.ft. The solid lines represent

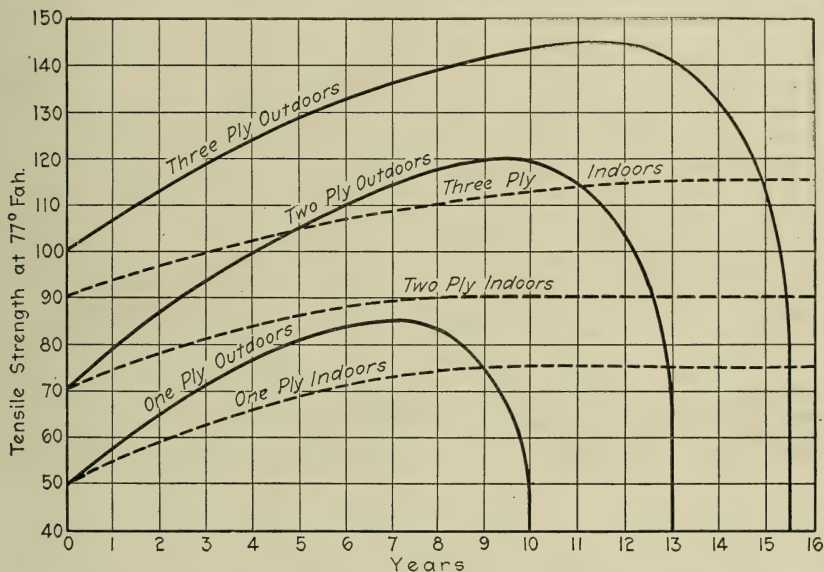

FIG. 208.—Tensile Strength Curves of Prepared Roofings on Exposure.

the strength of the outdoor samples, and the dotted lines the corresponding strength of samples aged indoors. The following figures will interpret the diagram, viz.:

	One-ply.		Two-ply.		Three-ply.	
	Years.	Lbs.	Years.	Lbs.	Years.	Lbs.
Original strength.....	0	50	0	70	0	90
Maximum strength outdoor sample.....	7	85	10	120	12	145
Outdoor sample same strength as indoor.....	9	75	12½	90	15	115
Outdoor sample same strength as originally.....	10	50	13	70	15½	90

The mean effective lives of the roofings in question may be taken as 9, 12½ and 15 years respectively, and the maximum effective lives as 10, 13 and 15½ years. The life of the roofing may be prolonged by painting it with a high-grade bituminous paint, before the weather coating has entirely worn away.

Conducting Weathering Tests on Bituminous Paints, etc. Bituminous paints may similarly be tested by applying them in one or more coats to steel sheets or wooden panels, and observing their appearance at regular intervals. The following features should be recorded:

- (1) Loss of lustre.
- (2) Condition of the exposed surface.
- (3) Amount of dusting.
- (4) Influence of rubbing on the color.
- (5) Any chipping of the paint and exposure of the underlying surface.
- (6) Any corrosion in the case of the steel plates.

Items 2, 3 and 4 are recorded as in the foregoing tests on prepared roofings, and items 1, 5 and 6 in accordance with any convenient scale of measurement.

Much has been written concerning the methods for performing exposure tests on paints, and for further information on this subject, the reader is referred elsewhere.

FINIS

BIBLIOGRAPHY

DATE.	AUTHOR.	TITLE.	PUBLISHER.	CITY.
1847	Isidore Huguenet	"Asphaltes"	Libraire Scientifique-Industrielle Baudry & Co.	Paris
1863	Léon Malo	"Note sur l'asphalte, son origine, sa préparation, ses applications; suivie de divers documents sur la matière"	Eugene Lacroix	Paris
1866	Léon Malo	"Guide pratique pour la fabrication et l'application de l'asphalte et des bitumes"	Bernhard Friedrich Voigt Pub. Co.	Weimar
1867	W. Jeep	"Der Asphalt"	Weisenhauses Book Pub. Co.	Halle a. S. Washington, D. C.
1872	L. Meyn	"Digest of United States Patents for Paving and Roofing Compositions to Jan. 1, 1875, and English Paving Compositions to Jan. 1, 1874"	—————	London London
1875	L. W. Sinsabaugh	"The Application of Asphalt"	—————	Nürnberg
1878	Chabrier	"Asphalt and Its Application to Street Paving"	Fr. Korn Pub. Co.	Berlin
1879	Ellice Clark	"Untersuchung über natürliche Asphalt"	Polytechnic Book Co. (A. Seidel)	Zürich
1880	R. Kayser	"Der Asphalt, seine Geschichte, Gewinnung und Verwendung"	Orell Füssli & Co.	Minden
1880	Franz Wons	"Der Asphalt"	J. C. C. Bruns	Berlin
1881	J. T. Zetter	"Petroleum and Asphalt in Deutschland"	Julius Bohne	Berlin
1881	V. Dücker	"Die Baumaterialien der Asphaltstrassen"	—————	Berlin
1881	E. O. Schubarth	"Ueber Asphaltstrassen"	—————	Vienna, Budapest and Leipzig
1881	E. Dietrich	"Die Asphalt-Strassen"	A. Hartleben's Pub. Co.	Munich Paris
1882	E. Dietrich	"Die Fabrication der Dachpappe und der Anstrichmasse für Pappdächer"	—————	Berlin
1883	Dr. E. Luhmann	"Asphalt und Asphaltstrassen"	Baudry & Co.	Berlin
1888	E. O. Schubarth	"L'asphalte, son origine, sa préparation, ses applications"	Ernest Toeche Pub. Co.	London and New York
1888	Léon Malo	"Städtisches Strassenwesen und Städreingung"	Spon & Co.	Troy, N. Y.
1890	R. Baumeister	"Twenty Years' Practical Experiences of Natural Asphalt and Mineral Bitumen"	Rensselaer Society of Eng's Bailliere & Co.	Paris
1893	W. H. Delano	"Natural Asphaltum and Its Compounds"	—————	—————
1894	J. W. Howard	"Le pétrole, l'asphalte et le bitume"	—————	—————
1895	A. Jaccard	"Das Erdwachs, Ozokerite und Cerasin"	—————	—————
1897	Berlinerblau	—————	—————	—————

DATE.	AUTHOR.	TITLE.	PUBLISHER.	CITY.
1897	Letouze and Loyeau	"Traité pratique des travaux en asphalte"	E. Bernhard & Co.	Paris
1898	Clifford Richardson	"On the Nature and Origin of Asphalt" (Bull. No. 2)	Barber Asphalt Paving Co.	Long Island City, N. Y.
1898	Philippe Narcy	"Les bitumens"	P. Vicq-Dunod et Cie.	Paris
1899	A. S. Cooper	"The Genesis of Petroleum and Asphaltum in California" (Bull. No. 16)	Cal. State Mining Bureau	Sacramento
1899	E. Nöthling	"Der Asphalt"	22nd Annual Report of the U. S. Geol. Survey	Leipzig Washington, D. C.
1901	Geo. H. Eldridge	"The Asphalt and Bituminous Rock Deposits of the United States" (Part I, pp. 210-464)		
1901	Dr. Jenő Kovács	"Ueber Asphalt, sein Vorkommen, seine Verwendung und einschlägige Untersuchungen"	Pester Book Printing Co.	Budapest
1903	J. Muek	"Der Erdwachsbergbau in Boryslaw"	Julius Springer Book Co.	Berlin
1904	Willy Peterson-Kinberg	"Wie eine Moderne Teerdestillation mit Dachpappenfabrik eingerichtet sein Muss"	A. Hartleben's Pub. Co.	Vienna and Leipzig
1904	S. F. Peckham and O. H. Klein	"Asphalt Paving"	Report of the Commissioners of Accounts	New York City
1904	J. Swoboda	"Der Asphalt under seine Verwendung"		Hamburg and Leipzig
1904	V. Křepelka	"Ueber Methoden der Untersuchung der natürlichen von den künstlichen Asphalte"	Inaugural-Dissertation	Zürich
1906	Dr. Ed. Graefe	"Die Braunkohlenteer-Industrie"	Wilhelm Knapp Pub. Co.	Halle a. S.
1907	Dr. Theodor Posewitz	"Petroleum und Asphalt in Ungarn"	Printery of Franklin Co.	Budapest
1908	Clifford Richardson	"The Modern Asphalt Pavement"	John Wiley & Sons, Inc.	New York
1908	Rudolf Gregorius	"Mineral Waxes"	Scott Greenwood & Son	London
1908	Geo. W. Tillson	"Street Pavements and Paving Materials"	John Wiley & Sons, Inc.	New York
1908	William P. Judson	"Road Preservation and Dust Prevention"	Engineering News Pub. Co.	New York
1908	Dr. Ed. Graefe	"Laboratoriumsbuch für die Braunkohlenteer-Industrie"	Wilhelm Knapp Pub. Co.	Halle a. S.
1908	Wilhelm Friese	"Die Asphalte- und Teerindustrie"	Dr. Max Janécke Book Co.	Hanover
1908	T. Hugh Boorman	"Asphalts"	Wm. T. Comstock	New York
1908	Felix Lindenberg	"Die Asphalt-Industrie"	A. Hartlebens Verlag	Vienna and Leipzig
1908	Dr. A. Spiker	"Kokerei und Teerprodukte der Steinkohle"	Wilhelm Knapp Pub. Co.	Halle (Saale)
1909	S. F. Peckham	"Solid Bitumens"	Myron C. Clark Pub. Co.	New York and Chicago

DATE.	AUTHOR.	TITLE.	PUBLISHER.	CITY.
1909	C. Engler & H. Höfer	"Das Erdöl," Vol. I—1913; Vol. II—1909; Vol. III—1911	S. Herzel Pub. Co.	Leipzig
1910	Prévost Hubbard	"Dust Preventatives and Road Binders"	John Wiley & Sons, Inc.	New York
1910	Siegfried Franz Weil	"Ueber Asphalt und verwandte Industrien"	J. Eisenstein & Co., Publishers	Vienna and Leipzig
1911	L. L. Hutchison	"Asphalt and Petroleum in Oklahoma"	Bull. No. 2, Okla. Geol-Survey, Leader Printing Co.	Guthrie, Okla.
(Mar.)				
1911	K. Wernicke	"Die Isoliermittel der Elektrotechnik"	McGraw Hill Book Pub. Co., Inc.	Braunschweig New York
1913	Clifford Richardson	"Asphalt Construction for Pavements and Highways"	Frederich Viewig & Son	Braunschweig
1913	Dr. Hippolyt Köhler and Dr. Edmund Graefe	"Die Chemie und Technologie der natürlichen und künstlichen Asphalte"	D. Van Nostrand Co.	New York
1913	Arthur Danby	"Natural Rock Asphalts and Bitumens"	Dr. Francesco Vallardi, Pub.	Milan
1913	Ernesto Ascone	"L'industria dell'asfalto"	Scott, Greenwood & Son	London
1913	Dr. W. Scheithauer	"Shale Oils and Tars"	D. Van Nostrand Co.	New York
1914	Arthur R. Warnes	"Coal Tar Distillation"	John Wiley & Sons, Inc.	New York
1914	Arthur H. Blanchard and Henry B. Drowne	"Text Book on Highway Engineering"		
1914	S. C. Eells	"Preliminary Report on the Bituminous Sands of Northern Alberta"	Dept. of Mines, Canada	Ottawa
1914	Myron H. Lewis	"Modern Methods of Waterproofing"	The Norman W. Henley Pub. Co.	New York
1915	P. Hubbard and C. S. Reeve	"Methods for the Examination of Bituminous Road Materials"	U. S. Dept. Agri. Bull. No. 314	Washington, D. C.
1916	T. R. Agg	"The Construction of Roads and Pavements"	McGraw-Hill Book Co., Inc.	New York
1916	The Engineering Standards Committee	"British Standard Nomenclature of Tars, Pitches, Bitumens and Asphalts, and British Standard Specifications for Tar and Pitch"	Crosby Lockwood & Son	London
1916	Prévost Hubbard	"Laboratory Manual of Bituminous Materials"	John Wiley & Sons, Inc.	New York
1916	R. F. Bacon and W. A. Hamor	"The American Petroleum Industry"	McGraw-Hill Book Co., Inc.	New York
1917	A. W. Blanchard	"Highway Engineers' Pocketbook" (Section 12)	John Wiley & Sons, Inc.	New York
—	Dr. George Thenius	"Die technische Verwertung des Steinkohlenters"	A. Hartlebens Pub. Co.	Vienna, Budapest and Leipzig
—	Ludwig Sedna	"Das Wachs und seine technische Verwendung"	A. Hartlebens Pub. Co.	Vienna, Budapest and Leipzig

TEMPERATURE CONVERSION TABLE

FAHRENHEIT TO CENTIGRADE

F.°	0	10	20	30	40	50	60	70	80	90	Fractional Parts	
	C.	C.	C.	C.	C.	C.	C.	C.	C.	C.		
0	-17.7	-12.2	-6.6	-1.1	+4.4	+10.0	+15.5	+21.1	+26.6	+32.2		
100	37.7	43.3	48.8	54.4	60.0	65.5	71.1	76.6	82.2	87.7	F.°	C.°
200	93.3	98.8	104.4	110.0	115.5	121.1	126.6	132.2	137.7	143.3	1	0.5
300	148.8	154.4	160.0	165.5	171.1	176.6	182.2	187.7	193.3	198.8	2	1.1
400	204.4	210.0	215.5	221.1	226.6	232.2	237.7	243.3	248.8	254.4	3	1.6
500	260.0	265.5	271.1	276.6	282.2	287.7	293.3	298.8	304.4	310.0	4	2.2
600	315.5	321.1	326.6	332.2	337.7	343.3	348.8	354.4	360.0	365.5	5	2.7
700	371.1	376.6	382.2	387.7	393.3	398.8	404.4	410.0	415.5	421.1	6	3.3
800	426.6	432.2	437.7	443.3	448.8	454.4	460.0	465.5	471.1	476.6	7	3.8
900	482.2	487.7	493.3	498.8	504.4	510.0	515.5	521.1	526.6	532.2	8	4.4
1000	537.7	543.3	548.8	554.4	560.0	565.5	571.1	576.6	582.2	587.7	9	5.0

CENTIGRADE TO FAHRENHEIT

C.°	0	10	20	30	40	50	60	70	80	90	Fractional Parts	
	F.	F.	F.	F.	F.	F.	F.	F.	F.	F.		
-0	+32	+14	-4	-22	-40	-58	-76	-94	-112	-130		
+0	32	50	68	86	104	122	140	158	176	194	C.°	F.°
100	212	230	248	266	284	302	320	338	356	374	1	1.8
200	392	410	428	446	464	482	500	518	536	554	2	3.6
300	572	590	608	626	644	662	680	698	716	734	3	5.4
400	752	770	788	806	824	842	860	878	896	914	4	7.2
500	932	950	968	986	1004	1032	1040	1058	1076	1094	5	9.0
600	1112	1130	1148	1166	1184	1202	1220	1238	1256	1274	6	10.8
700	1292	1310	1328	1346	1364	1382	1400	1418	1436	1454	7	12.6
800	1472	1490	1508	1526	1544	1562	1580	1598	1616	1634	8	14.4
900	1652	1670	1688	1706	1724	1742	1760	1778	1796	1814	9	16.2
1000	1832	1850	1868	1886	1904	1922	1940	1958	1976	1994		

Black figures indicate recurring decimals

Examples: 567° F. = 293.33 + 3.888 = 297.22° C.; -85° C. = -112 - 9.0 = -121° F.

Met. Chem. Eng. 11, 394, 1913; 8, 123, 1910.

SUBJECT INDEX

A

- Absorption test of:
 bituminized roofings, 563
 bituminous compositions, 552, 576
 insulating papers, 438
 paints, 576
- Acetone, 41, 188, 466
 solubility in, *see* "solubility"
- Acetone oils, 188, 189, 465
- Acetylenes, 33
- Acid asphalt, *see* "sludge asphalt"
- Acid oil distillate, 304
- Acids:
 asphaltous, *see* "asphaltous acids"
 fatty, *see* "fatty acids"
 free, *see* "free acids"
 resin, *see* "resin acids"
 tar, *see* "tar acids"
- Acid sludge, *see* "sludge"
- Acid-sludge asphalt, *see* "sludge asphalt"
- Acid value, 543
- Adhesive compositions, 392
- Adhesive compounds for:
 built-up roofing, 442, 444
 waterproofing, 442
- Adhesive or adhesiveness test, 481, 506:
 Kirschbraun's, 507
 Osborne's 506
- Aegerite, 151
- Aeonite, 151
- Africa:
 albertite in, *see* "albertite"
 asphalts in, *see* "asphalt"
- Aged surface of bituminous materials, 485
- Aggregate, *see* "mineral aggregate"
- Agitators, 303;
- Air condensers, 174
- Air-drying paints, 472
- Air-drying varnish, 473
- Albania, asphalt in, *see* "asphalt"
- Alberta, asphalts in, *see* "asphalt"
- Albert coal, 16, 153
- Albert shale, 162, 221
- Albertite, 153, 482:
 characteristics of, 149
 classification of, 26
 depolymerization of, 56, 314
 discovery of, 16
 distillation of, 221
 metamorphosis of, 56
- Albertite in:
 Australia, 156
 Canada, 153
 United States, 155
 Utah, 155
 West Africa, 156
- Albertite shales, 159
- Alcohols, 41, 185, 188, 189, 466:
 higher, *see* "higher alcohols"
- Algeria, asphalts in, *see* "asphalts"
- Alsace-Lorraine, asphalts in, *see* "asphalts"
- Ammonia, 42, 208, 220, 231, 233, 245
- Ammonium sulphate, 200, 221
- Analysis of:
 bituminized fabrics, 560
 bituminized mineral aggregates, 552
 bituminous cements, 570
 bituminous emulsions, 569
 bituminous paints, 570
 bituminous japans, 570
 bituminous varnishes, 570
 dried paint films, 573
- Analysis, ultimate, 42
- Anhydrides, 543:
 asphaltous acid, *see* "asphaltous acid anhydrides"
- Animal charcoal, 337
- Animal fats, 317, 341, 549
- Animal oils, 317, 341, 549
- Animal theories, *see* "theories"
- Animal waxes, 317, 549
- Anthracene, 41, 169, 245, 248, 550
- Anthracene oil, 231, 246, 248
- Anthracite coal, 60, 61, 226, 238, 482:
 classification of, 26
 metamorphosis of, 58, 60
- Anthracoxenite, 59
- Anthraquinone reaction, 481, 550
- Arabia, asphalts in, *see* "asphalts"
- Arcadian shale, 162, 221
- Argentine, asphalts in, *see* "asphalts"
- Argulite, 102
- Aristotle on asphalts, 10
- Arkansas, imponite in, *see* "imponite"
- Armature-carbons, 451
- Armored bituminized fabrics, 385
- Artificial asphalts, *see* "petroleum asphalts"
- Asbestos felt, 390
- Ash in felt, 389, 390, 568
- Asia, asphalts in, *see* "asphalts"
- Asiatic Russia:
 asphalts in, *see* "asphalts"
 elaterite in, *see* "elaterite"
- Asphalt:
 acid, *see* "acid asphalt"
 acid-sludge, *see* "acid-sludge asphalt"
 associated minerals, 47
 Barbados, *see* "Barbados asphalt"
 Bermudez, *see* "Bermudez asphalt"
 blown, *see* "blown petroleum asphalt"
 chemistry, of 15, 28
 classification of, 14, 26, 82
 compositon of, 42

Asphalt—*Continued*:

- condensed, *see* "blown petroleum asphalt"
- consumption in U. S., 67
- cracking of, 56, 277
- cut-back, *see* "cut-back asphalt"
- definition, of, 23⁷
- discovery in Cuba, 12
- discovery in Trinidad, 12
- distinguishing from fatty-acid pitch, 336
- Dubb's, *see* "Dubb's asphalt"
- exports from U. S., 66
- extraction of, *see* "extraction"
- for waterproofing, 442, 443
- geology of, 46
- heating of, 58
- imports into U. S., 66
- LaBrea, *see* "LaBrea asphalt"
- lakes, 48
- Limmer, *see* "Limmer asphalt"
- liquid, 82, 268
- Lobsann, *see* "Lobsann asphalt"
- Maracaibo, *see* "Maracaibo asphalt"
- metamorphosis of, 55
- native, *see* "native asphalt"
- Neuchatel, *see* "Neuchatel asphalt"
- origin of, 14, 55
- origin of word, 1
- oxidized, *see* "blown petroleum asphalt"
- oxidized petroleum, *see* "blown petroleum asphalt"
- oxygenized, *see* "blown petroleum asphalt"
- petroleum, *see* "petroleum asphalt"
- production of, 62, 63, 65
- properties of, 22
- pyrogenous, *see* "pyrogenous asphalts"
- Ragusa, *see* "Ragusa asphalt"
- residual, *see* "residual asphalt"
- rock, *see* "rock asphalt"
- seepages, 48
- Seyssel, *see* "Seyssel asphalt"
- sludge, *see* "sludge asphalt"
- springs, 8, 48
- straight-run, *see* "straight-run asphalt"
- sulphurized, *see* "sulphurized asphalt"
- Tataros, *see* "Tataros asphalt"
- Trinidad, *see* "Trinidad asphalt"
- use by Babylonians, 6
- use by Egyptians, 5
- use by Persians, 4
- use by Sumerians, 1
- use in Biblical times, 6
- Val de Travers, *see* "Val de Travers asphalt"
- veins, 50
- wurtzilite, *see* "wurtzilite asphalt"
- Asphalt-bearing shales, *see* "shales"
- Asphalt block pavements, 7, 373
- Asphalt broken stone pavement, 360
- Asphalt cement, *see* "asphaltic cement"
- Asphalt-cork composition, 453
- Asphaltenes, 527, 546
- Asphaltic cement, 370
- "Asphaltic coal," 16
- Asphaltic constituents, 481, 545
- Asphalt fillers, 382
- Asphaltic limestones, 26
- Asphaltic petroleum, *see* "petroleum"
- Asphaltic pyrobitumen, 149
 - classification of, 26
 - composition of, 43
 - definition of, 24

Asphaltic pyrobitumen—*Continued*

- heating of, 58
- metamorphosis of, 52, 55, 57
- origin of, 52
- production of, 62, 64
- properties of, 22
- veins of, 50
- Asphaltic pyrobituminous shales, 56, 158, 159, 482:
 - classification of, 26
 - metamorphosis of, 56, 57
- Asphaltic resins, 547
- Asphaltic sands, 71, 94
- Asphaltic shales in Colorado, 66
- Asphalt in:
 - Africa, 126
 - Albania, 10, 90
 - Alberta, 105
 - Algeria, 126
 - Alsace-Lorraine, 118
 - Arabia, 126
 - Argentina, 116
 - Asia, 91, 125
 - Asiatic Russia, 125
 - Austria, 120
 - Baku, 12
 - California, 66, 83, 102
 - Canada, 105
 - Cuba, 12, 86, 107
 - Dead Sea, 6, 11, 51, 125
 - Eastern Siberia, 91
 - Europe, 90, 116
 - France, 13, 90, 116
 - Germany, 13, 119
 - Greece, 90, 123
 - Indiana, 93
 - Italy, 122
 - Japan, 125
 - Kentucky, 66, 82, 92
 - Louisiana, 100
 - Mesopotamia, 8, 126
 - Mexico, 85, 107
 - Missouri, 93
 - Nigeria, 126
 - North America, 82, 92
 - Oklahoma, 66, 82, 93
 - Oregon, 85
 - Persia, 5, 8, 13
 - Philippines, 91
 - Portugal, 124
 - Rhodesia, 126
 - Russia, 124
 - Siberia, 91
 - Sicily, 123
 - South America, 86, 108
 - Spain, 124
 - Switzerland, 14, 117
 - Syria, 91, 125
 - Texas, 66, 100
 - Trinidad, 12, 108
 - United States, 82, 92
 - Utah, 66, 82, 101
 - Venezuela, 17, 86
- Asphaltites, 127, 340:
 - classification of, 26
 - composition of, 41, 43
 - definition of, 23
 - geology of, 46, 50
 - heating of, 58
 - metamorphosis of, 55, 57

- Asphaltes—*Continued*
 production of, 62, 64
 veins of, 50
 weather-resistance of, 340
- Asphaltes, Lake, 11, 12
- Asphalt-leather mixtures, 454
- Asphalt macadam, *see* "bituminous macadam"
- Asphalt mastic, 15, 374, 434
- Asphalt mastic floors, 374
- Asphalt mastic foot-pavements, 374
- Asphaltous acid anhydrides, 546
- Asphaltous acids, 546
- Asphalt paints: *see* "bituminous paints":
 use by Romans, 12
- Asphalt pavements, stone-filled, *see* "stone-filled sheet-asphalt pavements"
- Asphalt-saturated felt, 397, 429
- Asphalt saturator, 396
- Asphalt tiles, 374
- Asphaltum, *see* "asphalt"
- Asphaltum oil, *see* "residual oil"
- Austria:
 asphalt in, *see* "asphalt"
 pyrobituminous shales in, *see* "pyrobituminous shales"
- Australia:
 albertite in, *see* "albertite"
 elaterite in, *see* "elaterite"
 pyrobituminous shales in, *see* "pyrobituminous shales"
- Automobile oil, 268
- B
- Babylonians, use of asphalt by, 6
- Baffle-plate separator, 181
- Baffle scrubbers, 175
- Bagga, 76
- Baking japans, 477, 478
- Baking varnishes, 478
- Ball and ring fusing-point method, *see* "fusing-point"
- Barbados glance pitch, *see* "glance pitch"
- Base course, 360, 362, 367
- Base of bituminous paints, 462
- Base of paints, examination of, 571
- Bathvillite, 160
- Battery-box compound, 451
- Battery carbons, 451
- Baumé scale, 487
- Bedding course, 373
- Benzenes, 38
- Benzine, 211, 267, 281, 464, 466
- Benzol, 38, 227, 232, 245, 250, 465, 466
- Benzol, solubility in, *see* "solubility in benzol"
- Benzoline, 267
- Bermudez asphalt, 17, 86
- Biblical times, use of asphalt in, 6
- Bibliography, 583
- Binary mixtures, 342
- Binder:
 bituminous, *see* "bituminous binder"
 close, *see* "close binders"
 of briquettes, *see* "briquette binders"
 of sand cores, 251
 open, *see* "open binders"
- Binder course, 368
- Bitulithic specifications, 364
- Bitumen:
 definition of, 21
- Bitumen—*Continued*:
 early definition of, 13
 "elastic," 13
 origin of term, 1
- Bitumens:
 classification of, 26
 composition of, 42
 geology of, 46
 metamorphosis of, 52
 movement of, 50
 occurrence of, 47
 origin of, 46, 52
 properties of, 22
- Bituminated cork mixtures, 453
- Bituminated leather mixtures, 454
- Bituminized fabrics, 386, 560, 577
- Bituminized floor covering, 426
- Bituminized mineral aggregates, 352, 552
- Bituminized tapes, *see* "electrical insulating tapes"
- Bituminized wall board, 440, 560
- Bituminous:
 definition of, 21
- Bituminous adhesive composition, *see* "adhesive compositions"
- Bituminous binder, 357, 360, 365
- Bituminous broken stone pavements, 360
- Bituminous carpets, *see* "carpet coat"
- Bituminous cement, 365, 370, 462, 473
 analysis of, 570
- Bituminous coal, 60, 61, 168, 225, 482:
 classification of, 26
 coking, 226
 destructive distillation of, 227
 metamorphosis of, 58
 solubility of, 226
 volatile matter in, 168
- Bituminous coal shales, 159
- Bituminous coating compositions, 392, 437
- Bituminous compositions, 442
- Bituminous concrete pavements, 362
- Bituminous dust-laying oils, 268, 353
- Bituminous emulsions, 351, 354, 458, 569
- Bituminous enamels, 462, 476, 570
- Bituminous expansion joints, 383, 560
- Bituminous fillers, 7, 382
- Bituminous fuels, 454
- Bituminous gravel pavements, 360
- Bituminous japans, 462, 477, 570
- Bituminous lignite, 204
- Bituminous macadam, 360
- Bituminous materials, physical characteristics of
see "physical characteristics"
- Bituminous matter:
 discovery of in N. Y. State, 16
 discovery of in U. S., 16
 extraction of, 557
 in roofings, 564
 recovery of, 559
 separation from mineral aggregate, 557
- Bituminous mixtures, 338:
 classes of, 348
- Bituminous paints, 462:
 analysis of, 570
 resistance to moisture, 576
 weathering of, *see* "weathering tests"
- Bituminous paving materials, 352
- Bituminous rubber substitutes, 451
- Bituminous saturating compositions for:
 electrical insulating tape, 439

- Bituminous saturating compositions for—*Cont'd*:
 flooring fabrics, 426
 insulating and sheathing papers, 437
 prepared roofings, 390
 waterproofing membranes, 429
- Bituminous substances:
 blending of, 338, 348
 chemical composition of, 42
 chemistry of, 28
 classification of, 12, 19, 26
 consistency of, 338
 definition of, 21
 emulsification of, 351, 354, 458
 fluxing of, 339, 340, 348
 fusibility of, 339, 340, 482
 hardening of, 343
 hardness of, 339, 340
 heating of, 349
 improving amalgamation of, 344
 increasing tensile strength of, 345
 making more weatherproof, 345
 overheating of, 350
 preparing mixtures of, 338
 reducing susceptibility of, 344
 rendering war-like, 347
 softening of, 343
 terminology of, 19
 volatility of, 339, 340
 weatherproof properties of, 339, 340
- Bituminous surfacings, 357, 358
- Bituminous varnishes, 462, 474, 570
- Black grease, 326
- Black oil, 268
- Blast-furnace coal tar, 27, 166, 238, 242, 243, 482
- Blast-furnace coal-tar pitch, 27, 252, 482
- Blau gas, 261
- Blending, methods of, 338, 348
- Blistering, 580
- Blocks, asphalt, *see* "asphalt block pavements"
- Blower wax, 77
- Blowing, effects of, on asphalt, 290
- Blown asphalt, *see* "blown petroleum asphalt"
- Blown coal-tar pitches, 255
- Blown Oklahoma asphalts, 100
- Blown petroleum asphalt, 17, 18, 269, 287:
 carelessly prepared, 291
 classification of, 27
 composition of, 43, 289
 from asphaltic petroleum, 294
 from mixed-base petroleum, 294
 from non-asphaltic petroleum, 294
 properties of, 292, 341, 482
 relation between fusing-point and hardness, 293
 relation between fusing-point and sp.gr., 293
 weather-resistance of, 294, 341
- Blue-gas, 257
- Boghead cannel coal, 160
- Boiled tar, 188
- Bombiccite, 59
- Bone charcoal, 337
- Bone fat, 319, 320, 327
- Bone-fat pitch, 317, 328, 332, 335
- Bone grease, refining of, 327
- Bone oil, 337
- Bone tar, 27, 166, 317, 336, 337, 482
- Bone-tar pitch, 27, 317, 336, 337, 341, 482
- Bottom peat, 197
- Boussingault on asphalts, 15
- Branchite, 59
- Brazil, pyrobituminous shales in, *see* "pyrobituminous shales"
- Breaking weight, 390
- Brightening of petroleum products, 278
- Briquette binders, 454
- Briquetting, use of coal-tar pitch for, 251
- Browncoal, *see* "lignite"
- Burgundy pitch, 196
- Burlap, 390, 569
- Burning oil, 267
- Burning point, 481, 520
- Bursting strength, *see* "Mullen strength"
- Butyrellite, 59
- Byerlite, 18, 287, 289

C

- Cable pitch, 80
- California, asphalt in, *see* "asphalt"
- California residual asphalt, *see* "residual asphalt"
- Canada:
 albertite in, *see* "albertite"
 asphalt in, *see* "asphalt"
 pyrobituminous shales in, *see* "pyrobituminous shales"
- Canadol, 267, 464
- Candle pitch, 317
- Candle stock, 318
- Candle tar, 317
- Cannel coal, 60, 160, 169, 225
- Cannel coal shales, 159, 160
- Canneloid coal, 60
- Capillarity, 51
- Carbenes, 342, 481, 526
- Carbolic oil, 248
- Carbon, 28, 45, 481, 530
- Carbon disulphide, 466:
 non-mineral matter insoluble in, *see* "non-mineral matter"
 solubility in, *see* "solubility"
- Carbonization of bituminous substances, 350, 575
- Carbon oil, 267
- Carbons:
 for armatures, *see* "armature carbons"
 for batteries, *see* "battery carbons"
 for electric-lights, *see* "electric-light carbons"
- Carbon tetrachloride, 466, 527
- Carbureting oil, 258
- Carcass-rendering grease, refining of, 327
- Carpet coat, 357
- Carpeting medium, 269
- Cement:
 asphaltic, *see* "asphaltic cement"
 bituminous, *see* "bituminous cement"
- Cement waterproofing compounds, 434, 457
- Centrifugal deflector, 178
- Centrifugal method:
 for dehydrating, 182
 for separating bituminous matter, 558
- Centrifugal scrubbers, 177:
 Feld type, 177
 Reading type, 177
 Thiesen type, 177
- Ceresine, 26, 75
- Checking, 578
- Cheese pitch, 115
- Chemical tests, 481, 529
- China-wood oil, 463, 475, 478, 551
- Chloroform, 466
- Cholesterol, 331, 549, 551
- Cholesterol pitch, 317, 329

Classification of:

- asphalt, 14
- bituminous substances, 12, 19, 26
- Clay, collidal, *see* "colloidal clay"
- "Clay pigeons," coal-tar pitch used for, *see* "coal-tar pitch"
- Cleaning oil, 211, 213, 267
- Cleats, roofing, *see* "roofing cleats"
- Cleveland open tester, *see* "flash-point"
- Close binder, 368
- Coal:
 - Albert, *see* "Albert coal"
 - anthracite, *see* "anthracite coal"
 - asphaltic, *see* "asphaltic coal"
 - bituminous, *see* "bituminous coal"
 - cannel, *see* "cannel coal"
 - canneloid, *see* "canneloid coal"
 - coking, *see* "coking coal"
 - gas, *see* "gas coal"
 - geology of, 46
 - glance, *see* "glance coal"
 - parrot, *see* "parrot coal"
 - pitch, *see* "pitch coal"
 - subcannel, *see* "subcannel coal"
- Coal gas, 14, 31, 227
- Coal oil, 267
- Coal shales, 26, 58, 159
- Coal tar, 225:
 - blast-furnace, *see* "blast-furnace coal tar"
 - coke-oven, *see* "coke-oven coal tar"
 - composition of, 33, 38, 40, 44, 227, 245, 246
 - dehydration of, 246
 - discovery of, 13
 - distillation of, 246
 - distilled *see* "distilled coal tar"
 - distinguishing from oil-gas tar, 262
 - for saturating purposes, 251
 - gas-works, *see* "gas-works coal tar"
 - oxidizing of, 17
 - oxidized, *see* "oxidized coal tar"
 - producer-gas, *see* "producer-gas coal tar"
 - production of, 14, 225
 - products from, table facing 245
 - properties of, 242, 482
 - recognition of, 245
 - refined, *see* "refined coal tar"
 - refining of, 14, 245
 - solvents from, 15, 465, 466
 - stills used for, 246
- Coal-tar creosote, *see* "creosote"
- Coal-tar distillates, 464
- Coal-tar naphtha, *see* "naphtha"
- Coal-tar pitch, 225:
 - blast-furnace, *see* "blast-furnace coal-tar pitch"
 - blown, *see* "blown coal-tar pitch"
 - characteristics of, 253
 - classification of, 27
 - coke-oven, *see* "coke-oven coal-tar pitch"
 - cut-back, *see* "cut-back coal-tar pitch"
 - discovery of, 13
 - for battery-carbons, 251
 - for briquetting, 251
 - for clay pigeons, 251
 - for electric-light carbons, 251
 - for joint fillers, 251
 - for plastic compositions, 251
 - for sand cores, 251
 - for waterproofing, 251, 442
 - gas-works, *see* "gas-works coal-tar pitch"
 - hard, 251

Coal-tar pitch—*Continued*:

- medium, 251
- producer-gas, *see* "producer-gas coal-tar pitch"
- properties of, 252, 341, 482
- soft, 251
- straight-run, *see* "straight-run coal-tar pitch"
- water-resistance of, 255, 429
- weather resistance of, 255, 341
- Coal-tar saturated felt, 397, 429
- Coal-tar solvents, 15, 465, 466
- Coating compositions, 392, 437
- Coatings, *see* "bituminous coatings"
- Coefficient of expansion, 244, 259, 336, 488
- Coke, 200, 212, 232, 269, 279, 282
- Coke-oven coal tar, 166, 225, 233:
 - classification of, 27
 - production of, 233
 - properties of, 243, 244, 245, 482
- Coke-oven coal-tar pitch:
 - classification of, 27
 - properties of, 252, 482
- Coke ovens:
 - beehive, 233
 - Koppers, 237
 - Otto-Hoffman, 235
 - Semet-Solvay, 235
 - United-Otto, 236
- Cokey pitch, 115
- Coking coal, 60, 226
- Colloidal clay, 55, 113, 351, 354, 370, 459
- Colombia, glance pitch in, *see* "glance pitch"
- Color:
 - in mass, 481, 484
 - of roofing, 580
- Colorado:
 - gilsonite, in, *see* "gilsonite"
 - grahamite, in, *see* "grahamite"
 - shale in, *see* "shale"
- Combustion partial, *see* "partial combustion"
- Complex mixtures, 347
- Compositions or compounds:
 - adhesive, *see* "adhesive compositions"
 - battery-box, *see* "battery-box compound"
 - bituminous, *see* "bituminous compositions"
 - cement-waterproofing, *see* "cement-waterproofing compounds"
 - chemical, *see* "chemical composition"
 - coating, *see* "bituminous coating compositions"
 - core, *see* "core compounds"
 - electrical, *see* "electrical insulating compounds"
 - insulating, *see* "electrical insulating compounds"
 - junction-box, *see* "junction-box compound"
 - moulding, *see* "moulding compositions"
 - pipe-sealing, *see* "pipe-sealing compounds"
 - pot-head, *see* "pot-head compound"
 - saturating, *see* "bituminous saturating compositions"
 - vacuum, *see* "vacuum-impregnating compounds"
 - waterproofing, *see* "waterproofing compounds"
- Composition roofings, *see* "roofings"
- Compressive strength of bituminized aggregates, 554
- Compressor oil, 268
- Concrete, bituminous, *see* "bituminous concrete"
- Condensed asphalt, *see* "blown petroleum asphalt"
- Condensers, 174:
 - air, *see* "air condensers"
 - primary, *see* "primary condensers"

- Condensers—*Continued*:
 secondary, *see* "secondary condensers"
 water, *see* "water condensers"
- Condensing system, 171
- Congo copal, 452, 463
- Consistency test, 481, 494
- Consistency tester, 492, 494
- Consistometer, 498
- Continuous distillation of:
 coal tar, 249
 fatty acids, 319
 lignite tar, 210
 petroleum, 273
 shale tar, 222
- Coorongite, 150
- Coorongitic shale, 164, 221
- Core compounds, 454
- Cork, bituminated, *see* "bituminated cork mixtures"
- Corn oil, 463, 478
 refining of, 327
- Corn-oil-foots pitch, 317, 332
- Corn-oil pitch, 317, 327
- Cotton-oil pitch, 326
- Cotton pitch, 317, 326
- Cotton-seed foots, 326
- Cotton-seed-foots pitch, 317, 332
- Cotton-seed oil, 463
 refining of, 325
- Cotton-seed-oil-foots pitch, 326
- Cotton-seed-oil pitch, 317, 326
- Cotton-seed stearin, 319
- Cotton-stearin pitch, 317, 326
- Course:
 base, *see* "base course"
 bedding, *see* "bedding course"
 binder, *see* "binder course"
 foundation, *see* "foundation course"
 intermediate, *see* "intermediate course"
 surface, *see* "surface course"
 wearing, *see* "wearing course"
- Covering, bituminized floor, *see* "bituminized floor covering"
- Cracked distillate, 282
- Cracking, 56, 165, 173, 272, 282
- Cracking distillation, 272, 282
- Cream-separator oil, 268
- Creosote or creosote oil:
 from coal tar, 248, 379, 430
 from lignite tar, 208, 212, 214
 from peat tar, 200, 201
 from wood tar, 189, 465
- Creosote preservatives, 16, 379
- Crude scale wax, 308
- Crude wax, 308;
- Cuba:
 asphalts in, *see* "asphalt"
 discovery of asphalt in, 12
 grahamite in, *see* "grahamite"
- Cube method for fusing-point, *see* "fusing-point"
- Cushion, 373, 380
- Cushion layer, 380
- Cut-back asphalt, 277
- Cut-back coal-tar pitch, 251
- Cyclic hydrocarbons, *see* "hydrocarbons"
- Cyclo-olefines, 37
- Cyclo-paraffines, 34
- Cylinder oil, 268, 278
- Cylinder stock, 278, 280
- Cymogene, 267, 464
- D
- Damar, 452, 463
- Damp-proofing methods, 434
- Damp-proofing paint, 434, 469
- Dead oil, 248
- Dead Sea:
 asphalt in, *see* "asphalt"
 glance pitch in, *see* "glance pitch"
- Definition of:
 asphalt, *see* "asphalt"
 asphaltite, *see* "asphaltite"
 bitumen, *see* "bitumen"
 bituminous, *see* "bituminous"
 pitch, *see* "pitch"
 pyrobitumen, *see* "pyrobitumen"
 pyrogenous, *see* "pyrogenous"
 tar, *see* "tar"
 wax, *see* "wax"
- Deflectors, 174, 178
- Degras, *see* "wool degras"
- Degras oil, 329
- Degras stearin, 329
- Dehydration of:
 asphalts, 68
 petroleum, 269
 tars, 180
- Density, *see* "specific gravity"
- Depolymerization, 56, 58, 313, 475:
 of albertite, *see* "albertite"
 of elaterite, *see* "elaterite"
 of wurtzilite, *see* "wurtzilite"
- Deposits of asphalt, *see* "asphalt"
- Deposit:
 primary, *see* "primary deposit"
 secondary, *see* "secondary deposit"
- Destructive distillation, 165, 167
- Diacetylenes, 34
- Diazo reaction, 481, 549
- Dimethyl sulphate test, 538
- Dinite, 59
- Diodorus Siculus on asphalt, 11
- Diolefines, 33
- Dioscorides on asphalt, 11
- Dippel oil, 337
- Disintegrator, 178
- Distillate oil, 379
- Distillates:
 coal-tar, *see* "coal-tar distillates"
 petroleum, *see* "petroleum distillates"
 pyrogenous, *see* "pyrogenous distillates"
- Distillation:
 continuous, *see* "continuous distillation"
 destructive, *see* "destructive distillation"
 dry, *see* "destructive distillation"
 of coal tar, 246
 of hardwood, 185
 of lignite tar, 210
 of ozokerite, 75
 of peat, 200
 of petroleum, 270,
 of rosin, 193
 of shale tar, 222
 of soft wood, 189
 of wood, 184
 fractional, *see* "fractional distillation"
 intermittent, *see* "intermittent distillation"
 steam, *see* "steam distillation"
 vacuum, *see* "vacuum distillation"
- Distillation olein, 321
- Distillation stearin, 321

Distillation test, 421, 520:
 flask method, 520
 retort method, 522
 Distilled coal tar, 251
 Distilled-grease olein, 329
 Distortion under heat, 444, 555
 Dopplerite, 59
 Dow ductility test, *see* "ductility test"
 Dried paint films:
 analysis of, 573
 Dryers, 463, 475
 Dubb's asphalt, 269, 294
 Duck, 390, 569
 Ductility test, 481, 502,
 Durability of:
 paints, 582
 roofings, 408, 581
 Dust, *see* "fillers"
 Dust catchers, 238
 Dusting, 578
 Dust-laying oils, 268, 353
 Dust palliatives, 353
 Dust preventatives, 353
 Duxite, 59
 Dynamo oil, 268
 Dysodile, 59

E

Earth, fullers', *see* "fullers' earth"
 Earth wax, *see* "mineral wax"
 Earthy peat, 198
 Eastern Siberia, asphalts in, *see* "asphalts"
 Ebano, 289
 Egypt, glance pitch in, *see* "glance pitch"
 Egyptians, use of asphalt by, 5
 "Elastic bitumen," 13
 Elaterite, 149, 150, 482:
 classification of, 26
 depolymerization of, 56
 discovery of, 13
 distinguishing characteristics of, 149, 482
 metamorphosis of, 56
 Elaterite in:
 Asiatic Russia, 150
 Australia, 150
 England, 150
 Electrical insulating compounds, 447, 448
 Electrical insulating japans, *see* "japans"
 Electrical insulating tape, 439, 560
 Electrical insulation:
 bituminized papers for, 438
 montan wax for, *see* "montan wax"
 Electrical method for dehydrating petroleum, *see*
 "petroleum"
 Electrical precipitators, 174, 180
 Electric-light carbons, 451
 Elements in bituminous substances, 42
 Elliot closed tester, *see* "flash point"
 Elutriation test, 363, 541
 Emulsification, 351, 354, 459
 Emulsions, *see* "bituminous emulsions"
 Enamels, bituminous, *see* "bituminous enamels"
 Engine distillate, 267
 Engine oil, 268
 England:
 elaterite in, *see* "elaterite"
 hatchettite in, *see* "hatchettite"
 pyrobituminous shales in, *see* "pyrobituminous
 shales"

Engler viscosity, 491
 Enriching oil, 258
 Esterification, 545
 Ester value, 544
 Euosmite, 59
 Europe, asphalts in, *see* "asphalt"
 Evaporation of bituminous materials, 575
 Examination of, *see* "analysis of":
 aggregates, *see* "aggregates"
 broken slag, *see* "slag"
 broken stone, *see* "stone"
 filler, *see* "filler"
 sand, *see* "sand"
 Expansion, coefficient of, 244, 259, 336, 488
 Expansion joints, *see* "bituminous expansion
 joints"
 Export oil, 281
 Exposure test, 345, 577, 582
 Extraction with solvents, of
 California sand asphalt, 73
 Extraction with water of:
 Alberta asphaltic sand, 71, 72
 Alsace-Lorraine asphaltic limestone, 72
 Bastennes asphaltic limestone, 72
 Mexican asphaltic sand, 71
 Oklahoma asphaltic sand, 71, 72, 99
 ozokerite, 72, 75
 San Valentino asphaltic limestone, 72
 Seyssel asphaltic limestone, 72
 Tataros asphaltic limestone, 72, 121
 Texas asphaltic limestone, 72
 Extractors, 72, 178, 180

F

Fabrics:
 armored, *see* "armored bituminized fabrics"
 asbestos, *see* "asbestos felts"
 bituminized, *see* "bituminized fabrics"
 felted, *see* "felted fabrics"
 flooring, *see* "flooring fabrics"
 insulating, *see* "insulating fabrics"
 roofing, *see* "roofing fabrics"
 sheathing, *see* "sheathing fabrics"
 waterproofing, *see* "waterproofing fabrics"
 woven, *see* "woven fabrics"
 Fastening devices for roofings, 415
 Fat:
 animal, *see* "animal fat"
 bone, *see* "bone fat"
 neutral, *see* "neutral fat"
 Fat pitch, 317
 Fats and oils:
 hydrolyzing of, 318
 refining of, 317
 Fatty-acid pitch, 317, 320, 341, 482:
 behavior on heating, 332
 characteristics of, 333
 classification of, 27
 coefficient of expansion, 336
 distinguishing from asphalts, 336
 for baking japans, 332, 477, 478
 for varnishes, 333
 from bone-fat, 332, 335
 from cotton-seed-oil foots, 332, 335
 from corn-oil foots, 332, 335
 from garbage, 332, 335
 from lard, 332, 334
 from packing-house refuse, 332, 335

- Fatty-acid pitch—*Continued*:
 from palm oil, 332, 335
 from tallow, 332, 335
 from sewage, 332, 335
 from wool-grease, 332, 335
 properties of, 330, 333
 weather-resistance of, 332, 336, 341
- Fatty acids, 41, 543, 544, 572:
 distillation of, 319
- Feld system of cooling, 249
 analysis of, 568
- Felt:
 asbestos, *see* "asbestos felt"
 asphalt-saturated, *see* "asphalt-saturated felt"
 coal-tar-saturated, *see* "coal-tar-saturated felt"
 microscopic examination of, 568
 rag, *see* "rag felt"
 roofing, *see* "roofing felt"
 slaters', *see* "slaters' felt"
 tarred, *see* "tarred felt"
- Felted fabric, 386
- Fibre stress, 554
- Fibres in felt: 568
- Fibrous matter, 452, 564
- Fibrous peat, 198
- Fibrous wax, 76
- Fichtelite, 59.
- Fillers, 346, 393, 402, 452, 463, 539:
 asphaltic, *see* "asphaltic fillers"
 bituminous, *see* "bituminous fillers"
 examination of, 541, 571
 incorporation of, 350
 joint, *see* "joint fillers"
 mineral, *see* "mineral fillers"
 pitch, *see* "pitch fillers"
- Filters, 174, 180
- Fish oil, 463, 478
- Fixed carbon, 481, 520
- Flash-point, 464, 481, 517:
 Cleveland open tester, 519
 Elliot closed tester, 519
 N. Y. State closed tester, 519
 Pensky-Martens closed tester, 517
- Flask method of distillation, *see* "distillation test"
- Flavius Josephus, on asphalt, 11
- Float test, 493
- Flooring fabrics, *see* "bituminized floor coverings" 426:
 testing of, 560
- Floor oil, 268
- Floors, asphalt mastic, *see* "asphalt mastic"
- Flotation oils, 189, 455
- Flotation process, 455
- Flowing temperature, 444, 515
- Flow point *see* "flowing temperature"
- Flux, 268, 285, 343:
 Pittsburgh, *see* "Pittsburgh flux"
 Ventura, *see* "Ventura flux"
- Fluxing, 339, 343
- Fluxing oil, 274
- Flux oil, 268, 282
- Foot paths, *see* "asphalt mastic"
- Foot pavements, *see* "asphalt mastic"
- Foots oil, 278, 279, 308
- Forrest's hot extraction method, 557
- Fossil resins, 56, 463, 475, 551, 572
- Foundation course of:
 asphalt block pavements, 373
 bituminous concrete, 362
- Foundation course of—*Continued*:
 bituminous macadam, 360
 sheet asphalt pavements, 367
 wood-block pavements, 378
- Fractional cooling, *see* "Feld system"
- Fractional distillation, 270
- Fracture, 481, 485
- France, asphalts in, *see* "asphalt"
- Free acids, 543
- Free carbon, 342, 481, 534, 575
- Free mineral matter, *see* "mineral matter"
- Fuel lignite, 204
- Fuel oil, 267, 277, 278, 279, 280, 281, 283, 454, 464
- Fuel ratio, 60
- Fuels, bituminous, *see* "bituminous fuels"
- Fullers' earth, 278, 281, 308, 393
- Fullers' grease, 329
- Fullers'-grease pitch, 317, 329
- Fusing-point, 481, 510:
 ball and ring method, 513
 cube method, 514
 Kramer-Sarnow method, 510
- G
- Galicia, ozokerite in, *see* "ozokerite"
- Garbage grease, refining of, 328
- Garbage pitch, 317, 328, 332, 335
- Gas:
 Blau, *see* "Blau gas"
 coal, *see* "coal gas"
 illuminating, *see* "illuminating gas"
 marsh, *see* "marsh gas"
 natural, *see* "natural gas"
 oil, *see* "oil gas"
 oil-water, *see* "oil-water gas"
 Pintsch, *see* "Pintsch gas"
 water, *see* "water gas"
- Gas coal, 226
- Gas-engine oil, 268
- Gas liquor, 232
- Gas oil, 173, 211, 213, 223, 257, 258, 267, 277
 278, 279, 280, 281, 283, 464
- Gasoline, 267, 277, 278, 279, 280, 281, 283, 464
- Gas pressure, 51
- Gas-works coal tar, 166, 227, 242, 482:
 classification of, 27
 coefficient of expansion of, 244
 composition of, 244, 245, 253
 distillation of, 246
 from horizontal retorts, 242
 from inclined retorts, 242
 from vertical retorts, 242
 properties of, 243, 482
 recovery of, 230
 refining of, 245
 separation of, 230
 yield of, 231
- Gas-works coal-tar pitch, 482:
 characteristics of, 253
 classification of, 27
 properties of, 252, 482
- Gas-works retort, 227:
 continuously operating, 229
 horizontal, 227, 229
 inclined, 227, 229
 vertical, 227, 229
- Geological formations, 46
- Geology of:
 asphaltites, *see* "asphaltites"
 asphalts, *see* "asphalts"

Geology of—Continued:

- bitumens, *see* "bitumens"
- coals, *see* "coals"
- mineral waxes, *see* "mineral waxes"
- non-asphaltic pyrobitumens, *see* "non-asphaltic pyrobitumens"
- petroleum, *see* "petroleum"
- pyrobitumens, *see* "pyrobitumens"
- Geomyricite, 59
- Germany:
 - asphalts in, *see* "asphalt"
 - pyrobituminous shales in, *see* "pyrobituminous shales"
- Gilsonite, 127, 482:
 - characteristics of, 128
 - classification of, 26
 - discovery of, 17
 - "firsts," 129
 - for manufacturing paints, 129, 471, 478
 - mining methods, 133
 - mixtures with linseed oil, 471
 - mixtures with residual oil, 129
 - production in U. S., 64
 - "seconds," 129
 - "selects," 129
- Gilsonite in:
 - Colorado, 127
 - United States, 130
 - Utah, 66, 127, 130
- Glance coal, 59
- Glance pitch, 133, 482:
 - characteristics of, 127, 133
 - classification of, 26
 - for manufacturing varnishes, 135
- Glance pitch in:
 - Barbados, 134
 - Colombia, 135
 - Dead Sea, 135
 - Egypt, 136
 - Mexico, 134
 - South America, 135
 - Syria, 135
 - West Indies, 134
- Glycerine, *see* "glycerol"
- Glycerol, 481, 543, 549
- Goudron, 317
- Grahamite, 136, 482:
 - characteristics of, 127, 136
 - classification of, 26
 - discovery of, 16
 - distillation of, 221
 - fluxing of, 349
 - mixtures with residual oil, 141, 147
 - production in U. S., 64
- Grahamite in:
 - Colorado, 143
 - Cuba, 144
 - Mexico, 144
 - Oklahoma, 140
 - Texas, 139
 - Trinidad, 146
 - United States, 137
 - West Virginia, 137
- Granularmetric analysis, *see* "mineral matter"
- Gravitation, 51
- Gravity, *see* "specific gravity"
- Grease:
 - bone, *see* "bone grease"
 - carcass-rendering, *see* "carcass-rendering grease"

Grease—Continued:

- garbage, *see* "garbage grease"
 - packing-house, *see* "packing-house grease"
 - refuse, *see* "refuse grease"
 - sewage, *see* "sewage grease"
 - wool, *see* "wool grease"
 - yellow, *see* "yellow grease"
 - Greese, asphalt in, *see* "asphalt"
 - "Greek fire," 10
 - Green oil, 222
- H
- Hair cracks, 580
 - Hannibal on asphalt, 10
 - Hardening, spontaneous, *see* "spontaneous hardening"
 - Hardness scale, 495
 - Hardness test, 481, 494
 - Hard wax, 76
 - Hardwood, distillation of, *see* "distillation"
 - Hardwood tar, 191, 482:
 - characteristics of, 191
 - classification of, 27
 - Hardwood-tar pitch, 192, 482:
 - characteristics of, 192
 - classification of, 27
 - Hartine, 59
 - Hartite, 59
 - Harvester oil, 268
 - Hatchettine, *see* "hatchettite"
 - Hatchettite, 15, 78
 - Hatchettite in:
 - England, 79
 - Scotland, 79
 - Head-light oil, 267
 - Heat, effect of, 52, 58
 - Heating in flame, behavior on, 509
 - Heat tests, 481, 509, 555:
 - of bituminized fabrics, 563
 - Heavy acetone oils, 189, 465
 - Heavy oils:
 - from coal-tar, table facing 245
 - from wood, 188
 - Herodotus on asphalt, 8
 - Higher alcohols, 543, 549
 - Hill peat, 197
 - Hippocrates on asphalt, 10
 - Historical review, 1
 - Hofmannite, 59
 - Homogeneity test, 481, 484
 - Horizontal retort, 171, 227
 - Hubbard consistency tester, 492
 - Hubbard pycnometer method, 489
 - Hurdle scrubbers, 175
 - Hutchison tar tester, 492
 - Hydraulic main, 174, 230, 231, 260
 - Hydrocarbons, 28, 543, 548:
 - acetylene series, 33
 - aliphatic, *see* "open chain"
 - aromatic, *see* "cyclic"
 - benzenes, 38
 - cyclic, 30, 34
 - cyclo-olefines, 37
 - diacetylene series, 34
 - diolefine series, 33
 - naphthene series, 34
 - olefine series, 32
 - olefine-acetylene series, 33
 - open chain, 29, 30
 - paraffine series, 30

Hydrocarbons—*Continued*:

- polycyclic polymethylenes, 37
- polycyclic polynaphthenes, 38
- ring, 30, 34
- terpenes, 37
- Hydrogen, 28, 45, 481, 530
- Hydrolene, 289
- Hydrolysis of oils and fats by:
 - ferments, 324
 - mixed process, 322
 - sulpho-compounds, 322
 - sulphuric acid, 321
 - Twitchell's process, 323
 - water, 318
- Hydrolyzing fats and oils, 318
- Hydrometer method, 486
- Hydrostatic pressure, 51, 431

I

- Ice-machine oil, 268
- Ichthyol, 121
- Identification of, *see* "analysis of"
- Illuminating gas:
 - discovery of, 13
 - enriching of, 231, 258
 - manufacture of, 227, 254
 - yield of, 232, 258
- Illuminating oil:
 - from lignite tar, 213
 - from petroleum, *see* "kerosene"
 - from shale tar, 223
- Immersion test, *see* "absorption test"
- Impact test, 555
- Imports of asphalts into U. S., *see* "asphalts"
- Impregnating compounds, *see* "bituminous saturating compounds"
- Impsonite, 149, 156, 482:
 - characteristics of, 149, 156
 - classification of, 26
 - metamorphosis of, 56
- Impsonite in:
 - Arkansas, 157
 - Nevada, 157
 - Oklahoma, 157
 - United States, 157
- Inclined retort, 171, 227
- Indiana asphalts in, *see* "asphalts"
- Individual shingles, *see* "shingles"
- Inorganic theories, *see* "theories"
- Insulating:
 - compounds, *see* "electrical insulating compounds"
 - fabrics, 386, 560
 - japans, *see* "japans"
 - papers, 433, 438, 560
 - tape, *see* "electrical insulating tape"
- Insulation:
 - cold, *see* "insulating papers"
 - cold-storage, *see* "insulating papers"
 - electrical, *see* "electrical insulating compounds"
 - heat, *see* "insulating papers"
- Integral waterproofing:
 - compounds, 457
 - method, 434, 457
- Intermediate course, 368
- Intermediate oil, 223, 267
- Intermittent distillation processes, 210, 222, 247, 270, 319

- Ionite, 59
- Iron pitch, 115
- Italy, asphalt in, *see* "asphalt"

J

- Japan, asphalts in, *see* "asphalt"
- Japans, *see* "bituminous japans"
- Jelly, petroleum, *see* "petroleum jelly"
- Jet, 60
- Joadja shale, 164
- Joint filler, 382
- Joints, *see* "bituminous expansion joints":
 - preformed, *see* "preformed joints"
- Junction-box compound, 450

K

- Kabaite, 79
- Kapak, 313
- Kaumazite, 203
- Kauri gum, 452, 463, 573
- Kauri varnish, 573
- Kentucky, asphalts in, *see* "asphalt"
- Kerosene, 267, 277, 278, 279, 280, 281, 282, 283, 303, 464, 466
- Kerosene shales, 164
- Kettles, *see* "melting tanks"
- Keltte, varnish, *see* "varnish kettle"
- Killed foots, 326
- Kimmeridge shales, 163, 221
- Kindebal, 77
- Kirschbraun adhesive test, *see* "adhesive test"
- Köflachite, 59
- Kontakt, 323
- Korite, 289
- Kramer-Sarnow method for fusing-point, *see* "fusing-point"

L

- LaBrea asphalt, 89
- Lactones, 330, 331, 543
- Lactone value, 543
- Lake Asphaltites, 11, 12
- Lakes, 48
- Lake, Trinidad, *see* "Trinidad Lake asphalt"
- Laminated roofings, *see* "roofings laminated"
- Lamp oil, 267
- Land asphalt, *see* "Trinidad land asphalt"
- Lard oil, 463
- Laying roofings, *see* "roofings"
- Laying shingles, *see* "shingles"
- Lep, 77
- Leather, bituminated, *see* "bituminated leather mixtures"
- Leucopetrin, 59
- Leucopetrite, 59
- Libollite, 156
- Liebermann-Storch reaction, 481, 551
- Light acetone oils, 189, 465
- Light oil:
 - from coal tar, table facing 245, 246, 248
 - from wood, 188
- Light petroleum, 267
- Lignite, 59, 61, 204:
 - bituminous, *see* "bituminous lignite"
 - briquetting of, 205, 209
 - classification of, 26
 - distillation of, 211
 - fuel, *see* "fuel lignite"
 - metamorphosis of, 58 59

- Lignite—*Continued*:
 non-bituminous, *see* "non-bituminous lignite"
 properties of, 482
 retort, *see* "retort lignite"
 volatile matter in, 168
- Lignite shales, 58, 159
- Lignite tar, 166, 203:
 classification of, 27
 composition of, 41
 discovery of, 14
 properties of, 209, 482
 refining of, 210
- Lignite-tar pitch, 203, 341:
 characteristics of, 214, 550
 classification of, 27
 properties of, 215, 482
 weather-resistance of, 341
- Lignitic shales, 26, 159, 161, 164
- Ligroin, 267
- Limestone, asphaltic, *see* "asphaltic limestone"
- Limmer asphalt, 13, 119
- Linseed, oil, 463, 471, 475, 478
- Liquid paraffine, 269
- Livingston, process for refining petroleum, 274
- Lobsann asphalt, 118
- Lothian shale, 163, 221
- Louisiana, asphalt in, *see* "asphalt"
- Lubricating oil:
 from lignite-tar, 211
 from peat-tar, 201
 from petroleum, 268, 277, 278, 279, 280, 281,
 283, 303
 from shale tar, 223
- Lustre, 481, 485
- M
- Macadam, *see* "bituminous macadam"
- Machine oil, 268
- Magma oil, 329
- Maltha, 25
- Malthenes, 527
- Manila copal, 452, 463
- Manjak, 63, 134, 146
- Manufactured products, testing of, 552
- Maracaibo asphalt, 89
- Marble wax, 76
- Marco Polo on asphalt, 12
- Marcus Vitruvius on asphalt, 11
- Marsh gas, 31, 53
- Masonry paints, 469
- Mastic, asphalt, *see* "asphalt mastic"
- Matka, 77
- Mechanical analysis of aggregates, *see* "mineral aggregate"
- Mechanical scrubbers, 174, 177
- Melanchyme, 59
- Mellite, 59
- Melting, behavior on, 509
- Melting point, 510
see also "fusing-point"
- Melting tanks, 69
- Membrane waterproofing, 428, 434, 560
- Mesopotamia, asphalts in, *see* "asphalt"
- Metamorphosis of:
 anthracite coal, *see* "anthracite coal"
 asphalt, *see* "asphalt"
 asphaltic pyrobitumen, *see* "asphaltic pyrobitumen"
 asphaltic pyrobituminous shales, *see* "asphaltic pyrobituminous shales"
- Metamorphosis of—*Continued*:
 asphaltites, *see* "asphaltites"
 bituminous coal, *see* "bituminous coal"
 bitumens, *see* "bitumens"
 coal shales, *see* "coal shales"
 elaterite, *see* "elaterite"
 imponite, *see* "imponite"
 lignite, *see* "lignite"
 lignite shales, *see* "lignite shales"
 mineral waxes, *see* "mineral waxes"
 peat, *see* "peat"
 ozokerite, *see* "ozokerite"
 wurtzilite, *see* "wurtzilite"
- Methods of examination, *see* "analysis"
- Mexico:
 asphalt in, *see* "asphalt"
 glance pitch in, *see* "glance pitch"
 grahamite in, *see* "grahamite"
- Microscopic examination of:
 bituminous substances, 484
 fibres, 568
 mineral matter, 539
- Middle oil, table facing 245, 246, 248
- Middletonite, 59
- Middlings, 267
- Mill, paint, *see* "paint grinding mill"
- Mineral aggregate:
 bituminized, *see* "bituminized mineral aggregate"
 examination of, 539, 559
 granulometric analysis of, 539, 559
 of asphalt mastic, 377
 of bituminous concrete pavements, 362
 of bituminous macadam, 360
 of bituminous surfacings, 358
 of sheet asphalt pavements, 369
 separation from bituminous matter, 557
- Mineral colza oil, 268
- Mineral fillers, 346, 393, 436, 539
- Mineral matter, 481, 538:
 admixed, 393, 567
 chemical analysis of, 539
 combined with non-mineral constituents, 539
 granulometric analysis of, 539, 559
 microscopic examination of, 539
 separation from bituminous matter, 557
 specific gravity of, *see* "specific gravity"
 surfacings of, *see* "surfacings"
 uncombined, 539
- Mineral oil, *see* "petroleum"
- Mineral seal oil, 268
- Mineral sperm oil, 268
- Mineral surfacings, *see* "surfacings"
- Mineral waxes, 74, 307, 340, 482:
 behavior on heating, 58
 classification of, 26
 composition of, 32
 definition of, 23
 geology of, 46
 metamorphosis of, 55, 56, 57
 properties of, 22
 solubility of, 467
- Missouri, asphalts in, *see* "asphalts"
- Mixed-base petroleum, *see* "petroleum"
- Mixers, 350, 372
- Mixtures of bituminous substances:
 binary, *see* "binary mixtures"
 complex, *see* "complex mixtures"
 tertiary, *see* "tertiary mixtures"
- Moh's hardness scale, 495

- Moisture, *see* "water"
- Moisture, effect on:
- bituminized fabrics, 438, 563
 - bituminized mineral aggregates, 552
 - bituminized substances, 576
- Montan wax, 79, 161, 205, 207
- classification of, 26
 - for electrical insulation, 81
 - in Saxony, 80
 - properties of, 340, 482
 - weather-resistance of, 340
- Moulding compositions, 452
- Muckite, 59
- Mullen strength of:
- burlap or duck, 569
 - felt, 390, 569
 - paper, 436, 438
- Multiple shingle strip, *see* "shingle strip"
- Mummies, 5, 11, 12
- N
- Naphtha from:
- coal tar, table facing 245, 248, 465, 466
 - lignite tar, 211, 213
 - peat tar, 201
 - petroleum, 267, 277, 279, 280, 281, 282, 303, 464
 - shale tar, 222, 223,
- Naphtha, solubility in 88° petroleum, *see* "solubility"
- Naphtha, solvent, *see* "solvent naphtha"
- Naphtha, V. M. & P., *see* "V. M. & P. naphtha"
- Naphthalene, 40, 169, 227, 231, 245, 248, 481, 535
- Naphthenes, 34
- Native asphalts:
- behavior on heating, 58
 - classification of, 26
 - composition of, 43
 - distinguishing from residual asphalts, 298, 545
 - impure, 92
 - metamorphosis of, 55, 57
 - production in U. S., 64
 - properties of, 340, 482
 - pure, 82
 - weather-resistance of, 340
- Native mineral waxes, *see* "mineral waxes"
- Natural asphalts, *see* "native asphalts"
- Natural gas, 25, 31
- Nebuchadnezzar on asphalt, 7
- Needle penetrometer, *see* "penetrometer"
- Neft-gil, 59
- Neuchatel asphalt, 13, 14, 118
- Neudorfite, 59
- Natural fats, 544
- Neutral oil, 268
- Nevada, impsomite in *see* "impsomite"
- New York, discovery of bituminous matter in, *see* "bituminous matter"
- New York State flash-point tester, *see* "flash-point"
- Nigeria, asphalts in, *see* "asphalts"
- Nigrite, 155
- Nitrogen, 42, 232, 481, 533
- Nitrogenous bodies, 42
- Nomenclature, *see* "terminology"
- Non-asphaltic petroleum, *see* "petroleum"
- Non-asphaltic pyrobitumens:
- classification of, 26
 - composition of, 41, 43
 - definition of, 24
 - geology of, 46
- Non-asphaltic pyrobitumens—*Continued*:
- heating of, 58
 - metamorphosis of, 58
 - origin of, 58
 - properties of, 22
 - veins of, 50
- Non-asphaltic pyrobituminous shales, 158, 159, 482
- Non-bituminous lignite, 204
- Non-mineral matter insoluble in carbon disulfide, 526
- North America, asphalt in, *see* "asphalt"
- "Number" of:
- burlap, 390
 - duck, 390
 - felt, 389, 569
 - paper, 436
- O
- Obispo, 289
- Odor on heating, 481, 509
- Oil or oils:
- acetone, *see* "acetone oils"
 - animal, *see* "animal oils"
 - bone, *see* "bone oil"
 - creosote, *see* "creosote oil"
 - degras, *see* "degras oil"
 - Dippel, *see* "Dippel oil"
 - dust-laying, *see* "bituminous dust-laying oils"
 - export, *see* "export oil"
 - flotation, *see* "flotation oils"
 - gas, *see* "gas oil"
 - illuminating, *see* "illuminating oil"
 - magma, *see* "magma oil"
 - palm, *see* "palm oil"
 - pine, *see* "pine oil"
 - residual, *see* "residual oils"
 - rosin, *see* "rosin oil"
 - seek, *see* "seek oil"
 - shale, *see* "shale tar"
 - vegetable, *see* "vegetable oils"
 - wool, *see* "wool oil"
- Oil-bearing shales, *see* "shales"
- Oil-forming shales, *see* "shales"
- Oil gas, 259
- Oil-gas tar, 166, 173, 259:
- classification of, 27
 - distinguishing from coal tar, 262
 - properties of, 262, 482
 - refining of, 263
- Oil-gas-tar pitch, 263:
- classification of, 27
 - distinguishing from coal-tar pitch, 264
 - properties of, 263, 341, 482,
 - weather-resistance of, 341
- Oilite, 162
- "Oil shales," 154, 158
- see* also "pyrobituminous shales"
- Oil-water gas, 260
- Oily constituents, 547
- Oklahoma:
- asphalts in, *see* "asphalt"
 - grahamite in, *see* "grahamite"
 - impsomite in, *see* "impsomite"
- Oklahoma asphalts:
- blown, *see* "blown Oklahoma asphalts"
 - extraction of, *see* "extraction with water"
 - for paving purposes, *see* "paving"
- Olefinaetylenes, 33
- Olefines, 32

- Oleo-resin, 193
 Once-run oil, 222
 Open binder, 368
 Open-chain hydrocarbons, *see* "hydrocarbons"
 Orchard heating oil, 280
 Orchard oil, 268
 Orepuhi shale, 164, 221
 Origin of the expression:
 asphalt, 1
 bitumen, 1
 Ornamental roofings, *see* "roofings"
 Osborne adhesive test, *see* "adhesive test"
 Oven for volatility test, 516
 Oxidation of bituminous materials, 575
 Oxidized asphalt, *see* "blown petroleum asphalt"
 Oxidized coal tar, 17, 255, 287
 Oxidized petroleum asphalt, *see* "blown petroleum asphalt"
 Oxygen, 44, 481, 534
 Oxygenated bodies, 41
 Oxygenated asphalt, *see* "blown petroleum asphalt"
 Ozokerite, 32, 74:
 classification of, 26
 discovery of, 15
 distillation of, 75
 extraction with water, 72, 75
 metamorphosis of, 56
 properties of, 75, 77, 340, 482
 weather-resistance of, 340
 Ozokerite in:
 Galicia, 76
 Rumania, 77
 Russia, 77
 Texas, 78
 United States, 77
 Utah, 66, 77
- P
- Packages, roofing *see* "roofing packages"
 Packing-house grease, 327
 Packing-house pitch, 317, 332, 335
 Paints:
 air-drying, *see* "air-drying paints"
 analysis of, *see* "analysis"
 analysis of dried films, *see* "analysis"
 bituminous, *see* "bituminous paints"
 damp-proofing, *see* "damp-proofing paint"
 for masonry, 469
 for metal, 472
 for roofings, 470
 for wood, 472
 grinding, mill for, 469
 use by Romans, 12
 use of gilsonite in, *see* "gilsonite"
 use of shale-tar pitch in, 224
 weathering of, *see* "weathering tests"
 Palliatives, dust, *see* "dust palliatives"
 Palm oil, 319, 320
 Palm-oil pitch, 317, 332, 335
 Paper or papers, 436:
 electrical insulating, *see* "electrical insulation"
 insulating, *see* "insulating papers"
 sheathing, *see* "sheathing papers"
 Paraffinaceous mass, 211, 212, 307
 Paraffinaceous petroleum, *see* "non-asphaltic petroleum"
 Paraffine, *see* "paraffine wax"
 Paraffine distillate, 280, 282
 Paraffine flux, 268
 Paraffine liquid, *see* "liquid paraffine"
 Paraffine oil, 211, 213, 214, 268
 Paraffines, *see* "hydrocarbons"
 Paraffine solid, *see* "solid paraffines"
 Paraffine scale, 268
 Paraffine wax:
 classification of, 27
 composition of, 32
 discovery of, 15
 from lignite tar, 208, 210, 211, 214, 307
 from peat tar, 201, 307
 from petroleum, 268, 278, 279, 281, 283, 307
 from shale tar, 223, 307
 origin of name, 15
 properties of, 309, 482
 weather-resistance of, 310, 340
 Parolite, 289
 Parrot coal, 160
 Partial combustion, 165, 172
 Particles, size of, 363, 369, 399, 540
 Pavements, 352:
 asphalt block, *see* "asphalt block pavements"
 asphalt mastic, *see* "asphalt-mastic foot pavements"
 bituminous concrete, *see* "bituminous concrete pavements"
 first asphalt block, 7
 first use in London, 15
 first use in Paris, 16
 first use in United States, 16, 17
 sheet asphalt, *see* "sheet asphalt pavements"
 stone-filled sheet asphalt, *see* "stone-filled sheet asphalt"
 wood-block, *see* "wood-block pavements"
 Paving blocks, *see* "asphalt block pavements"
 Paving materials, bituminous, *see* "bituminous paving materials"
 Peat, 59, 61, 197:
 bottom, *see* "bottom peat"
 briquetting of, 199
 classification of, 26
 dehydrating of, 199
 distillation of, 200
 earthy, *see* "earthy peat"
 fibrous, *see* "fibrous peat"
 metamorphosis of, 58, 59
 pitchy, *see* "pitchy peat"
 properties of, 482
 turfy, *see* "turfy peat"
 volatile matter in, 168
 Peat tar, 27, 166, 197, 202, 482
 Peat-tar pitch, 27, 197, 201, 203, 341, 482
 Penetration test, 495
 Penetrometer, 495
 Pensky-Martens closed flash-point tester, *see* "flash-point"
 Perilla oil, 463
 Persia, asphalt in, *see* "asphalt"
 Persians, use of asphalt, by 4
 Petrol, 267
 Petrolatum, 269
 Petrolenes, 527
 Petroleum:
 asphaltic, 26, 37, 265
 brightening of distillates, *see* "brightening"
 classification of, 26
 composition of, 32, 38, 42, 43
 continuous distillation of, 273, 274
 cracking of, 272

Petroleum—Continued:

- definition of, 23
- dehydration of, 269, 270
- destructive distillation of, 272
- dry distillation of, 272, 279, 282
- fractional distillation of, 272
- geology of, 46
- heating of, 58
- heating under pressure, 269
- intermittent distillation, 270
- mixed-base, 26, 37, 58, 265
- non-asphaltic, 26, 32, 58, 265
- paraffinaceous, *see* "non-asphaltic"
- products obtained from, 266
- properties of, 22, 340, 482
- refining of, 270
- settling of, 269
- steam-distillation of asphaltic, 272, 277, 278
- steam-distillation of mixed-base, 278, 280
- steam-distillation of non-asphaltic, 278, 280
- steaming of distillates, *see* "steaming"
- straight-distillation of, 272
- topping process of refining, *see* "topping process"
- tower system of distilling, 273
- varieties of, 265
- weather-resistance of, 340

Petroleum asphalts, 265:

- blown, *see* "blown petroleum asphalt"
- composition of, 32
- production of in U. S., 64
- refineries in U. S. producing, 266

Petroleum distillates, 267

Petroleum ether, 267

Petroleum jelly, 269

Petroleum residues, 268:

- composition of, 41

Petroleum solvents, 464

Petroleum spirits, 267, 464

Petroleum springs, 48

Petroleum tailings, 268

Phenols, 41, 201, 214, 222, 226, 245, 248, 550

Philippines, asphalt in, *see* "asphalt"

Physical characteristics of bituminous materials, 480

Physical tests of bituminized fabrics, 560

Phytocollite, 59

Phytosteryl, 549

Pianzite, 59

Pigments, 393, 453, 463, 477, 539, 571

Pine oil, 190, 465

Pine tar, 27, 190, 191, 482

Pine-tar pitch, 192, 482

Pinoline, 194

Pintsch gas, 259

Pipe-dips, 224, 445

Pipe-sealing compounds, 445, 447

Pissasphaltum, 11

Pitch:

- blast-furnace coal-tar, *see* "blast-furnace-coal-tar pitch"
- bone-fat, *see* "bone-fat pitch"
- bone-tar, *see* "bone-tar pitch"
- Burgundy, *see* "Burgundy pitch"
- cable, *see* "cable pitch"
- candle, *see* "candle pitch"
- cheese, *see* "cheese pitch"
- cholesterol, *see* "cholesterol pitch"
- classification of, 27
- coking, *see* "coking pitch"

Pitch—Continued:

- coke-oven coal-tar, *see* "coke-oven coal-tar pitch"
 - composition of, 41, 42, 43, 44
 - corn-oil, *see* "corn-oil pitch"
 - corn-oil-foots, *see* "corn-oil-foots pitch"
 - cotton, *see* "cotton pitch"
 - cotton-oil, *see* "cotton-oil pitch"
 - cotton-seed-foots, *see* "cotton-seed-foots pitch"
 - cotton-seed-oil, *see* "cotton-seed-oil pitch"
 - cotton-stearin, *see* "cotton-stearin pitch"
 - definition of, 24
 - fat, *see* "fat pitch"
 - fatty-acid, *see* "fatty-acid pitch"
 - fuller's-grease, *see* "fuller's-grease pitch"
 - garbage, *see* "garbage pitch"
 - gas-works coal-tar, *see* "gas-works coal-tar pitch"
 - glance, *see* "glance pitch"
 - hardwood-tar, *see* "hardwood-tar pitch"
 - iron, *see* "iron pitch"
 - lignite-tar, *see* "lignite-tar pitch"
 - oil-gas-tar, *see* "oil-gas-tar pitch"
 - packing-house, *see* "packing-house pitch"
 - palm-oil, *see* "palm-oil pitch"
 - peat-tar, *see* "peat-tar pitch"
 - pine-tar, *see* "pine-tar pitch"
 - producer-gas coal-tar, *see* "producer-gas coal-tar pitch"
 - properties of, 22
 - rosin, *see* "rosin pitch"
 - seek-oil, *see* "seek-oil pitch"
 - sewage, *see* "sewage pitch"
 - shale-tar, *see* "shale tar pitch"
 - stearin, *see* "stearin pitch"
 - stearin-wool, *see* "stearin-wool pitch"
 - Voges, *see* "Voges pitch"
 - water-gas-tar, *see* "water-gas-tar pitch"
 - wood-tar, *see* "wood-tar pitch"
 - wool, *see* "wool pitch"
 - wool-fat, *see* "wool-fat pitch"
 - wool-grease, *see* "wool-grease pitch"
 - wurtzilite, *see* "wurtzilite pitch"
- Pitch coal, 59, 85
- Pitch fillers, 382
- Pitch Lake, *see* "Trinidad Lake"
- Pitch still, 320
- Pitchy peat, 198
- Pittsburgh flux, 269, 295
- Plastic compositions, 251, 442, 473
- Pliability of roofing, 560, 580
- Pliability test, 444, 560
- Pliny the Elder on asphalts, 12
- Plutarch on asphalts, 11
- Polycyclic, *see* "hydrocarbons"
- Polymerization of bituminous substances, 56, 576
- Pontianak copal, 463
- Poole, subterranean, 48
- Portugal, asphalt in, *see* "asphalt"
- Pot-head compound, 450
- Power distillate, 268
- Precipitators, electrical, *see* "electrical precipitator"
- Preformed joints, 453
- Preformed washers, 453
- Premoulded strips, 383
- Prepared roofings, *see* "roofings"
- Preservatives:
- creosote, *see* "creosote preservatives"
 - wood, *see* "wood preservatives"

Pressed oil, 307
 Preventatives, dust, *see* "dust preventatives"
 Primary condensers, 230
 Primary deposit, 50
 Producer:
 Fairbanks-Morse, 241
 Körting, 201
 Loomis-Pettibone, 241
 Mond, 242
 types of, 239
 Westinghouse, 242
 Producer gas, 172, 209
 Producer-gas coal tar, 27, 166, 239, 242, 243, 482
 Producer-gas coal-tar pitch, 27, 252, 482
 Production of:
 asphalt, *see* "asphalt"
 asphaltic pyrobitumens, *see* "asphaltic pyrobitumens"
 asphaltites, *see* "asphaltites"
 elaterite, *see* "elaterite"
 gilsonite, *see* "gilsonite"
 grahamite, *see* "grahamite"
 Purifiers, 231
 Pycnometer method for specific-gravity, 488
 Pyridine, 42, 200, 226, 236, 245
 Pyrobitumen:
 asphaltic, *see* "asphaltic pyrobitumens"
 associated minerals, 47
 classification of, 26
 composition of, 42, 43
 definition of, 21
 geology of, 46
 non-asphaltic, *see* "non-asphaltic pyrobitumen"
 occurrence of, 47
 origin of, 46
 properties of, 21
 Pyrobituminous shales, 155, 158
 Pyrobituminous shales in:
 Australia, 164
 Austria, 164
 Brazil, 163
 California, 161
 Canada, 162
 Colorado, 161, 221
 England, 163
 Germany, 164
 Kentucky, 161
 Missouri, 161
 Montana, 161
 Nevada, 161
 Scotland, 163
 Spain, 164
 United States, 161, 221
 Utah, 161, 221
 Virginia, 161
 Wyoming, 161, 221
 Pyrogenous, definition of, 21
 Pyrogenous asphalts, 27, 340
 Pyrogenous distillates, 27, 340
 Pyrogenous residues, 27, 340
 Pyrogenous waxes:
 classification of, 27
 properties of, 340
 Pyropissite, 73, 79, 160, 205, 221:
 in Saxony, 79, 205
 Pyropissitic shales, 164
 Pyroretin, 59

Q

Quinoline, 42, 226, 236, 245

R

Rag felt, 389
 Ragusa asphalt, 123
 Rain scrubbers, 175
 Raleigh, Sir Walter, on asphalt, 12
 Ready roofings, *see* "roofings"
 Red oil, 211, 212
 Refikite, 59
 Refined coal tar, 251
 Refined cylinder oil, 281
 Refined paraffine wax, 268, 309
 Refined scale wax, 309
 Refined tar, table facing 245
 Refined wax, 281
 Refining of:
 bone grease, *see* "bone grease"
 carcass-rendering grease, *see* "carcass-rendering grease"
 coal tar, *see* "coal tar"
 corn oil, *see* "corn oil"
 cottonseed oil, *see* "cottonseed oil"
 fats and oils, *see* "fats and oils"
 garbage grease, *see* "garbage grease"
 lignite tar, *see* "lignite tar"
 packing-house grease, *see* "packing-house grease"
 petroleum, *see* "petroleum"
 refuse greases, *see* "refuse greases"
 sewage grease, *see* "sewage grease"
 shale tar, *see* "shale tar"
 vegetable oils, *see* "vegetable oils"
 water-gas tar, *see* "water-gas tar"
 woolen-mill waste, *see* "woolen-mill waste"
 Refractive index, 537
 Refuse greases, refining of, 327
 Reservoirs, subterranean, 48
 Residual asphalt, 268, 277, 278, 280, 295:
 California grades, 299
 carelessly prepared, 296
 classification of, 27
 composition of, 43
 distinguishing characteristics, 297
 differentiating from native asphalts, 298, 545
 from asphaltic petroleum, 301
 from mixed-base petroleum, 300
 properties of, 297, 341, 482
 weather resistance of, 302, 341
 Residual oil, 268, 274, 277, 282, 283:
 classification of, 27
 composition of, 43
 from asphaltic petroleum, 283, 286
 from mixed-base petroleum, 284, 286
 from non-asphaltic petroleum, 284, 286
 mixtures with gilsonite, 129
 mixtures with grahamite, 141, 147
 properties of, 285, 340, 482
 weather-resistance of, 285, 340
 Residual pitch, *see* "residual asphalt"
 Residue, sulphonation, *see* "sulphonation residue"
 Residues, petroleum, *see* "petroleum residues"
 Residues, pyrogenous, *see* "pyrogenous residues"
 Residium, 279, 282, 283
 Resin acids, 41, 543, 544
 Resins, 452, 463, 573:
 asphaltic, *see* "asphaltic resins"
 fossil, *see* "fossil resins"
 Retinasphaltum, 59
 Retinite, 59

- Retort:
 construction of, 170
 Del Monte, 219
 gas-works, *see* "gas-works retort"
 Henderson, 219
 horizontal, *see* "horizontal retort"
 inclined, *see* "inclined retort"
 Pumpherton, 217
 Rolle, 206
 rosin, 193
 shale, 216
 vertical, *see* "vertical retort"
 Young & Fyfe, 218
- Retort lignite, 204
- Retort method of distillation, *see* "distillation test"
- Retort tar, 188
- Rhigolene, 267, 464
- Rhodesia, asphalt in, *see* "asphalt"
- Road binders, 251, 268
- Road oil, 268, 274, 280, 283, 285
- Rochlederite, 59
- Rock asphalt, 16, 95, 99
- Rocks, impregnated, 48
- Roll roofing, *see* "roofing"
- Romans, use of asphalt paints by, 12
- Roofing or roofings, 386:
 analysis of, 564
 built-up, 419
 color of, 580
 discovery of, 14
 fastening devices for, 415
 laminated, 408
 laying, 418
 multiple-layered, *see* "laminated"
 ornamental, 410
 pliability of, *see* "pliability test"
 production of, 425
 single-layered, 398
 tensile-strength of, *see* "tensile strength"
 testing of, 560
 types of, 560
 weathering tests of, 577
- Roofing cleats, 416
- Roofing fabrics, 386
- Roofing felt, 387
- Roofing packages, 417
- Roofing shingles, *see* "shingles"
- Rosin, 193, 341, 452, 463, 551, 573
- Rosin esters, 463, 475
- Rosin oils, 190, 194, 465, 551
- Rosin pitch, 27, 193, 195, 341, 482
- Rosin spirits, 190, 194, 195, 465
- Rosin varnish, 573
- Rubber, 448, 452
- Rubber substitutes, *see* "bituminous rubber substitutes"
- Rumania, ozokerite in, *see* "ozokerite"
- Russia:
 asphalt in, *see* "asphalt"
 ozokerite in, *see* "ozokerite"
- S
- Sand, 363, 401, 540
- Sandarac, 463
- Saponifiable constituents, 481, 542
- Saponifiable matter, 542, 547
- Saponification olein, 320
- Saponification stearin, 320
- Saponification value, 544
- Sarco, 289
- Saturated hydrocarbons, 30, 481, 537
- Saturating compositions, *see* "bituminous saturating compositions"
- Saturator, 404:
 asphalt, *see* "asphalt saturator"
 tar, *see* "tar saturator"
- Saxony:
 montan wax in, *see* "montan wax"
 pyropissite in, *see* "pyropissite"
- Scale wax, 268, 278, 279, 309:
 refined, *see* "refined scale wax"
 yellow crude, *see* "yellow crude scale wax"
- Scheererite, 15, 79:
 in Switzerland, 79
- Schleretinite, 59
- Schutte consistency tester, 494
- Scotland:
 hatchettite in, *see* "hatchettite"
 pyrobituminous shales in, *see* "pyrobituminous shales"
- Scrubbers:
 baffle, *see* "baffle scrubbers"
 centrifugal, *see* "centrifugal scrubbers"
 hurdle, *see* "hurdle scrubbers"
 mechanical, *see* "mechanical scrubbers"
 rain, *see* "rain scrubbers"
 static, *see* "static scrubbers"
- Seal-coat, 269, 357, 367
- Secondary condenser, 231
- Secondary deposit, 50
- Seconds, gilsonite, *see* "gilsonite"
- Sedimentation, 70
- Seek oil, 329
- Seek-oil pitch, 329
- Seepages, 48
- "Selects," gilsonite, *see* "gilsonite"
- Semi-bituminous coal, 60
- Semi-pyrobitumens, 161
- Semi-pyrobituminous shales, 161
- Settling tanks, 181
- Sewage grease, refining of, 328
- Sewage pitch, 317, 332
- Sewage sludge, 328
- Seysel asphalt, 13, 15, 116
- Shale, *see* "pyrobituminous shale"
- Shale oil, *see* "shale tar"
- Shales:
 Albert, *see* "Albert shales"
 albertite, *see* "albertite shales"
 Arcadian, *see* "Arcadian shales"
 asphalt-bearing, 158
 asphaltic, *see* "asphaltic shales"
 asphaltic pyrobituminous, *see* "asphaltic pyrobituminous shales"
 bituminous coal, *see* "bituminous coal shales"
 cannel coal, *see* "cannel-coal shales"
 coal, *see* "coal shales"
 coorongitic, *see* "coorongitic shales"
 distillation of, 216
 joadja, *see* "joadja shales"
 kerosene, *see* "kerosene shales"
 Kimmeridge, *see* "Kimmeridge shales"
 lignite, *see* "lignite shales"
 lignitic, *see* "lignitic shales"
 Lothian, *see* "Lothian shales"
 non-asphaltic, *see* "non-asphaltic pyrobituminous shales"
 oil, *see* "oil shales"
 oil-bearing, 158

- Shales—*Continued*:
 oil-forming, 158
 Orepuki, *see* "Orepuki shales"
 pyrobituminous, *see* "pyrobituminous shales"
 pyropissitic, *see* "pyropissitic shales"
 semi-pyrobituminous, *see* "semi-pyrobituminous shales"
 stellarite, *see* "stellarite shales"
 wurtzilite, *see* "wurtzilite shales"
- Shale tar, 166, 216, 220:
 classification of, 27
 discovery of, 13
 properties of, 221, 482
 refining of, 222
- Shale-tar pitch, 216:
 classification of, 27
 discovery of, 13
 properties of, 224
- Shea butter, 319, 320
- Sheathing fabrics, 386
- Sheathing papers, 433, 560
- Sheet asphalt pavements, 367
- Sheet roofings, *see* "roofings"
- Sherwood oil, 267
- Shingles:
 individual, 412
 laying, 418
 prepared-roofing, 412
 strip, 414
 wide-spaced, 414
- Shoe fillers, 454
- Sicily, asphalt in, *see* "asphalt"
- Sieburgite, 59
- Sieves, 540, 559
- Signal oil, 267
- Sitosteryl, 549
- Slack wax, 278, 279, 307
- Slag, examination of broken, 540
- Slaters' felt, 397
- "Slime," 6, 13
- Sludge, 278, 279, 374:
 sewage, *see* "sewage sludge"
- Solid asphalt, 269, 278, 279, 303:
 classification of, 27
 composition of, 43
 distinguishing characteristics of, 305
 properties of, 304, 341, 482
 weather-resistance of, 306, 341
- Smudge oil, 268, 280
- Soap stock, 318
- S. O. binder, 289
- Softening point, 556
- Solid paraffines, 31, 32, 481, 536
- Solubility in:
 acetone, 193, 528
 benzol, 57, 79, 528
 benzol and toluol, 528, 534
 carbon disulphide, 524
 carbon tetrachloride, 526
 petroleum naphtha (88° Bé.), 527
 various solvents, 528
- Solubility test, 481, 524
- Solvent naphtha, table facing 245, 465
- Solvents, 464:
 chemical, 466
 coal-tar, 15, 464
 evaporation of, 466
 examination of, 570
 flash-point of, 464, 465, 466
 from wood, 465
- Solvents—*Continued*:
 petroleum, *see* "petroleum solvents"
 Sommer hydrometer, 489
- South America:
 asphalt in, *see* "asphalt"
 glance pitch in, *see* "glance pitch"
- Soya-bean oil, 463, 478
- Spain, asphalt in, *see* "asphalt"
 pyrobituminous shales in, *see* "pyrobituminous shales"
- Specifications for:
 asphalt for waterproofing, 443
 asphalt mastic floors, 375
 asphalt-saturated felt, 429
 bitulithic pavements, *see* "bitulithic specifications"
 bituminous expansion joints, 384
 bituminous varnishes, 476
 coal-tar pitch for waterproofing, 442
 coal-tar saturated felt, 429
 creosote priming coat, 430
 creosote preservative for wood blocks, 379
 insulating tape, 440
 roofing felt, 390
 roofings, 424
 Topeka pavements, *see* "Topeka specifications"
 wooden paving blocks, 378
- Specific gravity test, 481, 486, 541:
 for bituminous matter, 486
 for mineral aggregates, 541
- Spindle oil, 268
- Spirits, petroleum, *see* "petroleum spirits"
- Spirits, rosin, *see* "rosin spirits"
- Spontaneous hardening, 576
- Springs, 8, 48
- Static scrubbers, 174, 175
- Steam distillation, 210, 222, 246, 272, 319
- Steaming of petroleum products, 278
- Stearin, degrass, *see* "degrass stearin"
- Stearin pitch, 317
- Stearin-wool pitch, 317
- Stellarite, 155, 221
- Stellarite shales, 162
- Stills for:
 coal-tar, 247
 fatty acids, 319
 lignite, 211
 petroleum, 270
 rosin, 193
 shale tar, 222
 wurtzilite, 313
- Still grease, 223
- Still wax, 310
- Stock, candle, *see* "candle stock"
- Stock, soap, *see* "soap stock"
- Stockholm tar, 190
- Stone, examination of broken, 540:
 wax, *see* "wax-stone"
- Stone-filled sheet-asphalt pavement, 362
- Stove oil, 267
- Strabo on asphalt, 11
- Straight-run asphalt, 277
- Straight-run coal-tar pitch, 251
- Straw oil, 268
- Streak on porcelain, 481, 485
- Strength:
 compressive, *see* "compressive strength"
 Mullen, *see* "Mullen strength"
 of burlap or duck, 569
 of felt, 390, 569

Strength—Continued:

- of paper, 436, 438
 - of roofing, 562
 - tensile, *see* "tensile strength"
 - transverse, *see* "transverse strength"
- Strength factor, 390, 436, 569
- Strips:
- premoulded, *see* "premoulded strips"
 - shingle, *see* "shingle strips"
- Subcanal coal, 60
- Substitutes, rubber, *see* "bituminous rubber substitutes"
- Suction producer, 240
- Sulphonation residue, 21, 481, 537
- Sulphur, 43, 481, 532
- Sulphurated bodies, 42
- Sulphurized asphalt, 269, 294
- Sumerians, use of asphalt by, 1
- Surface aged indoors, 481, 485
- Surface course, 361, 368, 372
- Surface mixtures, 357, 361, 366, 368
- Surfacings:
- bituminous, *see* "bituminous surfacings"
 - of mineral matter, 394, 569, 578
 - of vegetable matter, 395
- Susceptibility factor, 481, 501
- Sweater, 307
- Sweating process, 278, 307
- Switzerland:
- asphalt in, *see* "asphalt"
 - scheererite, in, *see* "scheererite"
- Syria:
- asphalt in, *see* "asphalt"
 - glance pitch in, *see* "glance pitch"

T

- Tabbyite, 83
- Tacitus on asphalt, 11
- Tailings, wax, *see* "wax tailings"
- Tallow, 319, 320
- Tape, *see* "electrical insulating tape"
- Tar:
- boiled, *see* "boiled tar"
 - blast-furnace, *see* "blast-furnace coal tar"
 - bone, *see* "bone tar"
 - browncoal, *see* "lignite tar"
 - candle, *see* "candle tar"
 - classification of, 27
 - coal, *see* "coal tar"
 - coke-oven, *see* "coke-oven coal tar"
 - composition of, 41, 42, 43, 44
 - definition of, 24
 - dehydration, of, 180
 - distillation of, *see* "distillation"
 - effect of temperature on, 168
 - gas-works, *see* "gas-works coal tar"
 - hardwood, *see* "hardwood tar"
 - heating of, 181, 182
 - lignite, *see* "lignite tar"
 - oil-gas, *see* "oil-gas tar"
 - oxidized, *see* "oxidized coal tar"
 - peat, *see* "peat tar"
 - pine, *see* "pine tar"
 - producer-gas, *see* "producer-gas coal tar"
 - production of, 165
 - properties of, 22, 340, 482
 - retort, *see* "retort tar"
 - separation of, 174
 - shale, *see* "shale tar"

Tar—Continued:

- Stockholm, *see* "Stockholm tar"
 - water-gas, *see* "water-gas tar"
 - weather-resistance of, 340
 - wood, *see* "wood tar"
- Tar acids, 244, 245, 536
- Tar extractors, 180, 230, 231
- Tar filter, 180
- Tar fog, 171
- Tarred felt, 397, 429
- Tar saturator, 396
- Tar tester, 492
- Tasmanite, 156
- Tataros asphalt, 72, 121
- Temperature scales, 586
- Tensile strength:
- of bituminized aggregates, 553
 - of bituminized fabrics, 438, 440, 562
 - of bituminized substances, 481, 505
 - of roofings, 562, 580
- Tensometer, 505
- Terminology, *see* "definition"
- Terpenes, 33, 37
- Tertiary mixtures, 347
- Testing of, *see* "analysis," also "examination":
- manufactured products, 552
 - raw materials, 480
- Tests, 481
- Texaco, 289
- Texas:
- asphalt in, *see* "asphalt"
 - grahamite in, *see* "grahamite"
 - ozokerite in, *see* "ozokerite"
- Theories:
- animal, 54
 - inorganic, 52
 - vegetable, 53
- Thermometer scales, *see* "temperature scales"
- Thickness factor of felt, 569
- Thickness of:
- bituminized fabrics, 562
 - felt, 390, 569
 - paper, 436
 - roofing, 562
- Tiles, asphalt, *see* "asphalt tiles"
- Toluol, 39, 465, 466, 528, 534
- Topeka specifications, 364
- Topping process for petroleum, 274
- Torbanehill mineral, 160
- Torbanite, 160, 221
- Total bitumen, *see* "solubility in carbon disulphide"
- erroneous use of expression, 21
 - tower system of distilling, *see* "petroleum"
- Transformer oil, 268
- Transverse strength of bituminized aggregates, 554
- Trinidad:
- asphalt in, *see* "asphalt"
 - grahamite in, *see* "grahamite"
- Trinidad asphalt, 108:
- composition of, 112
 - discovery of, 12
 - first use for paving purposes, 17
 - production of, 115
 - refining of, 113
- Trinidad lake, 12, 48, 108
- Trinidad lake asphalt, 108
- Trinidad land asphalt, 115
- Trinkerite, 59

Turpentine, 185, 189, 194, 465, 466:
 wood, *see* "wood turpentine"
 Turpentine substitute, 267, 464, 466
 Turfy peat, 198
 Twitchell process, 323
 Twitchell reagent, 323

U

Uintaite, *see* "gilsonite"
 Ultimate analysis, *see* "analysis"
 Uncombined mineral matter, *see* "mineral matter"
 Underwriters' Laboratories, Inc., 421
 United States:
 albertite in, *see* "albertite"
 asphalt consumed in, 67
 asphalt exported from, 66
 asphalt imported into, 66
 asphalt in, *see* "asphalt"
 bituminized matter discovered in, 16
 first pavement in, *see* "pavement"
 gilsonite in, *see* "gilsonite"
 grahamite in, *see* "grahamite"
 imponite in, *see* "imponite"
 ozokerite in, *see* "ozokerite"
 production of asphalt in, *see* "asphalt"
 pyrobituminous shales in, *see* "pyrobituminous shales"
 wurtzilite in, *see* "wurtzilite"
 Unsonifiable matter, 481, 547

Utah:

albertite in, *see* "albertite"
 asphalt in, *see* "asphalt"
 gilsonite in, *see* "gilsonite"
 ozokerite in, *see* "ozokerite"
 pyrobituminous shales in, *see* "pyrobituminous shales"
 wurtzilite in, *see* "wurtzilite"

V

Vacuum distillation, 210, 246, 273, 320
 Vacuum impregnating compounds, 449
 Val de Travers asphalt, 13, 16, 17, 118
 Varnish kettle, 468
 Varnishes:
 air-drying, *see* "air-drying varnishes"
 baking, *see* "baking varnishes"
 bituminous, *see* "bituminous varnishes"
 Vaseline, 211, 269
 Vegetable fats, 317
 Vegetable matter, surfacings of, *see* "surfacing"
 Vegetable oils, 317, 325
 Vegetable oils and fats, 341, 549
 Vegetable theories, *see* "theories, vegetable"
 Vegetable waxes, 549
 Veins, 50
 Venezuela, asphalt in, *see* "asphalt"
 Venezuela lake, 48, 86
 Ventura flux, 269
 Vertical retort, 170, 227
 Viscosity test, 481, 491
 V. M. & P. naphtha, 267, 281, 464
 Voids, 363
 Volatile matter, *see* "volatility test"
 Volatility test, 481, 516
 Vosges pitch, 196

W

Walchowite, 59
 Wall-board, *see* "bituminized wall-board"

Warrenite, 365
 Washers, *see* "scrubbers"
 Washers, preformed, *see* "preformed washers"
 Water, 41:
 determination of, 481, 529
 Water condensers, 174
 Water-gas, 173, 256, 257
 Water-gas tar, 166, 173:
 classification of, 27
 coefficient of expansion, 259
 property of, 259, 482
 refining of, 263
 Water-gas-tar pitch, 263:
 classification of, 27
 distinguishing from coal-tar pitch, 264
 properties of, 263, 264, 341, 482
 weather-resistance of, 341
 Waterproofing:
 asphalt for, *see* "asphalt"
 coal-tar pitch for, *see* "coal-tar pitch"
 integral, *see* "integral waterproofing"
 membrane, *see* "membrane waterproofing"
 Waterproofing compounds for:
 cement-mortar, 434, 457
 concrete, 434, 457
 Waterproofing fabrics, 386
 Waterproofing methods, 434
 Wax:
 animal, *see* "animal wax"
 blower, *see* "blower wax"
 crude scale, *see* "crude scale wax"
 fibrous, *see* "fibrous wax"
 hard, *see* "hard wax"
 marble, *see* "marble wax"
 mineral, *see* "mineral wax"
 montan, *see* "montan wax"
 paraffine, *see* "paraffine wax"
 pyrogenous, *see* "pyrogenous waxes"
 refined, *see* "refined wax"
 refined paraffine, *see* "refined paraffine wax"
 refined scale, *see* "refined scale wax"
 still, *see* "still wax"
 vegetable, *see* "vegetable waxes"
 white scale, *see* "white scale wax"
 wool, *see* "wool wax"
 yellow crude scale, *see* "yellow crude scale wax"
 Wax-stone, 75
 Wax tailings, 268, 279, 310:
 classification of, 27
 properties of, 311, 340, 482
 use as flux, 311, 343
 use in paints, 312
 weather-resistance of, 311, 340
 yield of, 282
 Wearing course, 368, 372
 Weathering tests, 574:
 of bituminized fabrics, 577
 of bituminous paints, 582
 Weight of bituminized fabric, 562
 Weiss' specific gravity method, 490
 West Africa, albertite in, *see* "albertite"
 West Indies, glance pitch in, *see* "glance pitch"
 Westphal balance, 487
 West Virginia, grahamite in, *see* "grahamite"
 Wheelerite, 59
 White oil, 267
 White scale wax, 281
 Wide-spaced shingles, *see* "shingles"
 Wood:
 distillation of, 185

- Wood—*Continued*:
 preservation of, 378, 456
 varieties of, 185
- Wood block pavements, 378
- Wood oils, 185, 465
- Wood preservation, 16, 378, 456
- Wood tar, 166, 184:
 classification of, 27
 earliest reference to, 13
 properties of, 191, 482
- Wood-tar pitch, 184, 188, 191:
 classification of, 27
 properties of, 192, 215, 341, 482
 weather-resistance of, 193, 341
- Wood turpentine, 190:
 destructively distilled, 465
 steam-distilled, 465
- Wool degreas, 329
- Woolen mill waste, refining of, 328
- Wool-fat pitch, 317, 329
- Wool grease, 317, 329, 341
- Wool-grease pitch, 317, 332 335, 336
- Wool oil, 329
- Wool pitch, 317, 329
- Wool wax, 329
- Woven fabrics, 390
- Wurtzilite, 150:
 characteristics of, 149, 151
- Wurtzilite—*Continued*:
 classification of, 26
 depolymerization of, 56, 313
 discovery of, 17
 in U. S., 150
 in Utah, 150
 metamorphosis of, 56
 properties of, 482
 production of, 64
- Wurtzilite asphalt, 313:
 classification of, 27
 distinguishing characteristics of, 315
 properties of 314, 341, 482
 use in paints, 316
 weather-resistance of, 316, 341
- Wurtzilite pitch, *see* "wurtzilite asphalt"
- Wurtzilite shales, 159
- Wyoming, pyrobituminous shales in, *see* "pyrobituminous shales"

X

- Xenophon on asphalt, 9
 Xylol, 39, 465, 466

Y

- Yellow crude scale wax 281
 Yellow grease, 327

LIBRARY OF CONGRESS



0 002 966 015 3